

F02 ELECTRIC ACTUATORS

The F02 series are compact, intelligent quarter-turn electric actuators for the accurate control of valves with torques from 35 to 2000 Nm / 308 to 17,700 lb.in.



FEATURES

- Low or high voltage single phase DC or AC power supply with 3-phase option
- Multiple adjustable stroking times to suit specific applications
- Interchangeable base plate and range of shaft inserts enable simple connection to any valve type
- Intelligent control unit prevents overheating
- Epicyclical gearing ensures reliable and smooth operation
- Top-mounted position indicator
- Constantly-engaged, hand wheel-operated manual override in case of power failure
- Bluetooth™ wireless connectivity for non-intrusive configuration, operation and diagnostics
- Optional local control panel for manual valve operation with additional open/close indicator
- Simple upgrade options for modulating control and network communication via DeviceNet or Profibus DP protocols
- Latched-type output contacts for fully open/fully close remote indication. Output contacts for monitor and blinker/local selector indication are also available

GENERAL APPLICATION

The F02 is available in six sizes and is designed for on/off or modulating control of butterfly, ball, rotary plug valves or dampers in a wide range of heavy industrial, chemical and petrochemical plants on and offshore.

APPROVALS

Waterproof: IP66/68 or NEMA 4/4X/6 (NEMA ICS6/NEMA 250) CAN/CSA C22.2 No 139-10 and UL 429-2009

Explosionproof: Ex d e IIB T5 Gb (Gas) Ex tb IIIC T100°C Db (Dust) (prefix c for model 2000)

TECHNICAL DATA

Power supply: Single phase from 24 to 48 V DC or AC at 50/60 Hz
Single phase from 100 to 240 V DC or AC at 50/60 Hz
3-phase from 208-240 V AC, 380-480 V AC and 500-575 V AC

Voltage fluctuations: +/- 10%

Frequency: +/- 5%

Torque output: From 35 to 2000 Nm / 308 to 17,700 lb.in.

Ambient temperature
Standard range: -25°C to +70°C / -13°F to 158°F

Low temp range: -40°C to +70°C / -40°F to 158°F

Conduit entry: M25/1" NPT

Bluetooth™ is a trademark of Bluetooth SIG. Inc, USA

F02 ELECTRIC ACTUATORS

COMPONENT PARTS - MODELS 063 / 125 / 250 / 500 / 1000

Part	Description	Quantity
1	Nut UNI5588 M6	2
2	Nut UNI5588 M8	2
3	Eccentric	1
4	Planocentric gear	2
5	Spacer	1
6	Ball bearing type 16002	1
7	Ball bearing type 16004	2
8	Ball bearing type 6001	1
9	ESH screw UNI5931- M6x8	1
10	HSHC screw UNI5931- M6x16	4
11	HSHC screw UNI5931- M4x14	7
12	HSHC screw UNI5931- M6x18	2
13	HSHC screw UNI5931- M6x25	4
14	HSHC screw UNI5931- M8x20	4
15	HSSC screw UNI5933- M4x10	1
16	Cover assembly	1
17	Drive and control unit	1
18	Handwheel	1
19	Output drive assembly	1
20	Standard housing	1
21	Stopper	2
22	Terminal block	1
23	Worm shaft flange	1
24	Anti-loosening washer UNI 8842-J6	1
25	Base plate ISO 5211 / F05-F07	1
26	Cover gasket	1*
27	Dowel pin UNI EN 22338	1
28	Earth stud	1
29	Fixed anulus	1
30	Gasket	1*
31	Indicator	1
32	Indicator shaft	1
33	Manual worm shaft	1
34	Motor pinion	1
35	O-ring Di=10.77/W=2.62	1*
36	O-ring Di=18.77/W=1.78	1*
37	O-ring Di=52.07/W=2.62	1*
38	O-ring Di=6.07/W=1.78	1*
39	Plug	1
40	Position label	1
41	Power clamps protection	1
42	Ring	2
43	Ring for pins alignment	1
44	Ring RW 7 UNI7433	2
45	Seal washer 8.3	2
46	Sliding ring	1
47	Snap ring for shaft D.6	1
48	Terminal block cover	1
49	Terminal board gasket	1*
50	Wheel	1

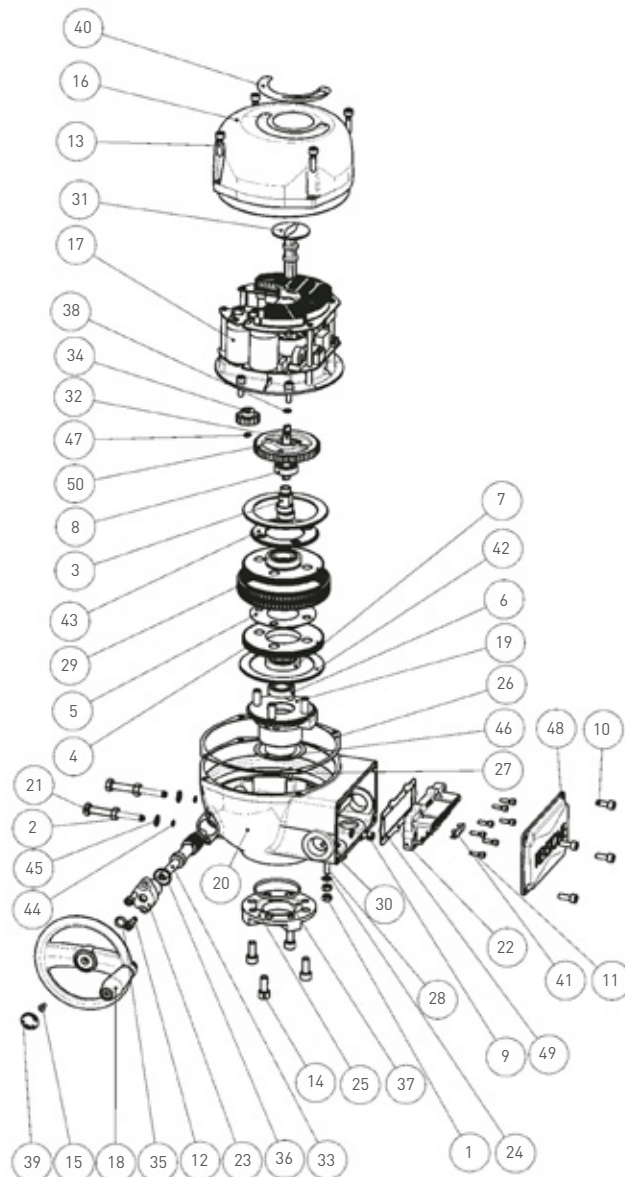

* Indicates recommended spare parts

F02 ELECTRIC ACTUATORS

COMPONENT PARTS - MODEL 2000

Part	Description	Quantity
1	Nut M20 ISO 4032 EN 24032	2
2	Ball bearing type 6006	1
3	Ball bearing type 16004	1
4	Ball bearing type 61908	1
5	HSHC screw UNI5931- M6x16	3
6	HSHC screw UNI5931- M12x30	4
7	HSHC screw UNI5931- M12x65	4
8	HSHC screw UNI5931- M8x25 A4-70	6
9	F02 actuator	1
10	Base housing	1
11	Base plate ISO 5211 / F12-F16	1
12	Bearing support	1
13	Bushing	2
14	Bushing	1
15	Bushing	1
16	Bushing	1
17	Dowel pin UNI EN 22338 D 8x20 type B	4
18	Gasket	1*
19	Hex head screw M20x80 UNI EN 24017	2
20	Idle wheel shaft	1
21	Needle bearing type NKI 22/16	2
22	O-ring Di=82.22/W=2.62	1*
23	Position wheel	1
24	Seal washer 20.3	2
25	Selector gear	1
26	Sliding ring	1
27	Upper vover	1
28	Wheel	2

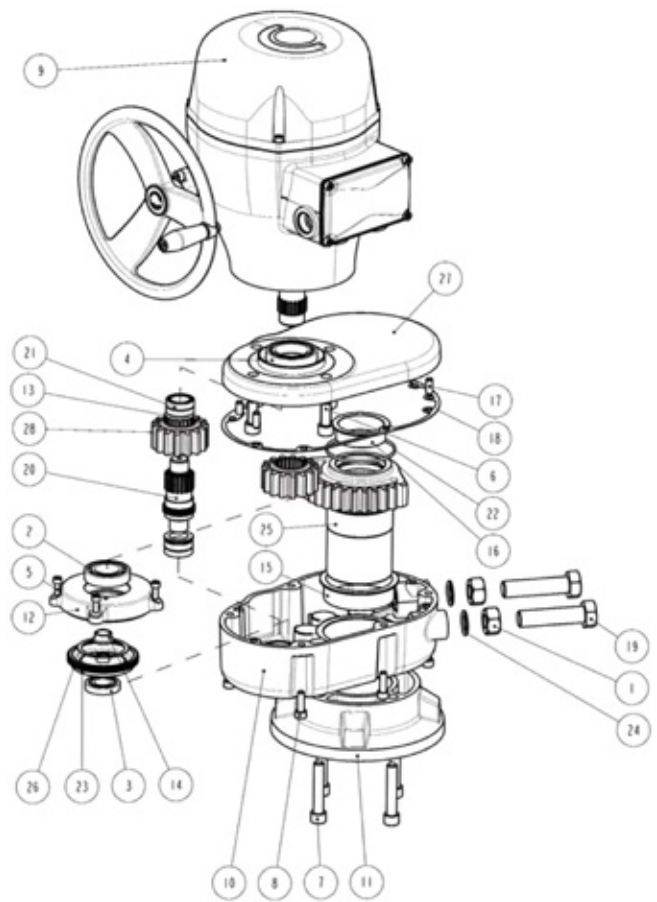

* Indicates recommended spare parts

F02 ELECTRIC ACTUATORS

DESIGN FEATURES

Mechanical connection to the valve

F02 actuators feature a multi drilled base plate and a range of drive inserts to allow direct mounting to almost all valve types according to the EN ISO 5211 and other manufacturers' standards.

Power supply

F02 can simply be connected to the local power supply. It accepts any single phase input voltages (from 24 to 48 V DC or AC and 100 to 240 V DC or AC). Alternatively 3 phase voltages from 208-240 V AC, 380-480 V AC and 500-575 V AC are also available

Electric motor thermostat

A thermostat to protect the motor temperature in hot applications is included as standard in the control circuit of the electric actuator.

Heater

A heater is standard available within the unit and is powered from the motor power supply. It is automatically activated when the temperature drops below 10°C in order to prevent condensation.

Actuator service

The standard actuator is suitable for open/close and modulating applications.

Compact and light design

F02 actuators are very compact and balanced for easy installation to small valves minimizing pipe work stress or loads to the valve shaft.

Actuator configuration

Each actuator is equipped with 2 rotary switches on the logic board to configure each function and parameter like position, torque, open/close speed and output contacts. Additionally each optional module has its own additional switches for its specific configuration.

Local manual override

A constantly engaged manual override (not rotating during motor operation) is fitted to all F02 actuators.

Torque and sizing

The F02 range comprises of six models, for operating torques of up to 2000 Nm / 17,700 lb.in. with a configurable operation time from 15 to 180 seconds. The nominal output torque value is constant along the entire stroke.

Non-intrusive configuration

With Bluetooth® wireless technology enabled on your PDA or PC all configuration requirements can be undertaken without opening the unit. Direct access to the F02 is then available for configuration and predictive/preventative maintenance information, including valve position, actuator speed, output torque, alarm and status.

Position monitoring

The F02 provides a local mechanical position indication. For remote indication the position is detected by a non-contact sensor. The open and close position are configured via the electronic control card.

Electronic controls

Internal drive to reverse the actuator rotation direction via remote control signals with internal 24 V DC or external 24 V DC/AC up to 120 V DC/AC power supply.

Output contacts

4 latched-type output contacts for fully open/fully close remote indication; 1 output contact for monitor (loss of power, torque alarm, high temperature alarm, travel alarm, position sensor, hardware malfunction, local interface malfunction, local selector in LOCAL); 1 output contact for blinker/local selector indication (local selector feature only with OM3 installed).

F02 ELECTRIC ACTUATORS

OPTIONAL MODULES AND PERFORMANCE

OPTIONAL MODULES

OM1 I/O additional module

Analog position INPUT 4-20 mA or 0-10 V DC
 Analog position OUTPUT 4-20 mA or 0-10 V DC
 4 additional SPST output contacts
 Optional Bluetooth interface

Monitor relay

Information about loss of input signal and Bluetooth failure are available on monitor relay output contact.

OM3 local interface

Local/remote selector
 OP/CL pushbuttons
 2 LEDs for local indication
 Available in WP version

OM13 3-wire module

110/240 V AC
 3-wire control module for open/close

Bus communication – network interfaces

OM9) Profibus DP V0/V1
 OM11) DeviceNet

OPTIONAL MODULES SELECTION TABLE

Order code	OM1 I/O additional module	OM3 local interface	Bluetooth component	OM9 PDP V0/V1	OM11 DeviceNet	OM13 3 wires module
P1	✓					
PA	✓	✓	✓			
P6	✓	✓				
P7	✓		✓			
P3		✓				
5P			✓	✓		
6P		✓	✓	✓		
5D			✓		✓	
6D		✓	✓		✓	
PG						✓

NOTES

- Each optional module (OMx) will be provided with its own installation and maintenance instructions.
- All modules except OM13 are available for both single phase and 3-phase voltage versions.
- Bluetooth component is integrated in the OM1, OM9 and OM11 card: not available for integration by local organizations, as a stand alone unit.
- OM13 is not available with 3-phase supply and for LV version (single phase voltage from 24 to 48 V DC/V AC).

F02 ELECTRIC ACTUATORS

PERFORMANCE AND APPROVALS

OPERATING TIMES

Model	Nominal torque (Nm / lb.in.)	Operating time (secs 90°) at selected step		
		8	6	4
063	63/600	15	28	48
125	125/1300	15	28	48
250	250/2500	15	28	48
500	500/5100	15	28	48
1000	1000/9100	24	45	80
2000	2000/17700	53	100	180

Times are guaranteed with a tolerance of $\pm 10\%$ on the 90° stroke

Approvals	
Waterproof	IP66/68 or NEMA 4/4X/6 (NEMA ICS6/NEMA 250) CAN/CSA C22.2 No 139-10 and UL 429-2009
Explosionproof	Ex d e IIB T5 Gb (Gas) Ex tb IIIC T100°C Db (Dust) (prefix c for model 2000)
Painting	ESPC for 1000 hrs salt spray resistance (ASTM D 2247-02 and ASTM B117-97)
Vibration and noise	1 to 500 Hz with 2 g peak acceleration (IEC60068-2-6-appendix B) 65 dB (grade A) (EN 21680)

F02 ELECTRIC ACTUATORS

OVERALL DIMENSIONS - MODELS 063 125 250 500 1000

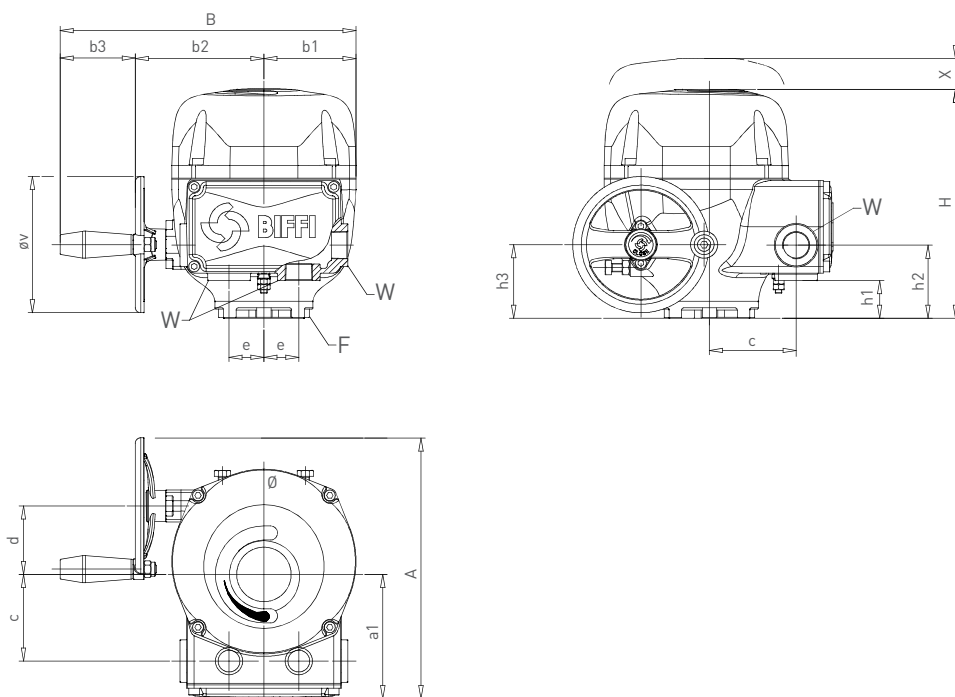

NOTES

W = Nr. 4 cable entries M25x1.5 acc. to ISO 724/965-1 (others available as special versions)

X = Space for cover removal

F = ISO 5211 Standard flange (others available)

F02 BASE UNIT MODELS 063 TO 1000 - METRIC (mm / kg)

Model	A	B	H	a1	b1	b2	b3	c	d	e	h1	h2	h3	$\varnothing v$	x	F	kg
063	239	272	210	114.0	85	118	69	80.0	63	32	35.5	67.0	67.5	125	175	F07	7.5
125	239	272	230	114.0	85	118	69	80.0	63	32	53.5	86.0	86.5	125	175	F10	9.5
250	295	332	287	129.0	109	154	69	95.0	76	32	63.5	95.0	92.0	180	230	F12	16.5
500	295	332	287	129.0	109	154	69	95.0	76	32	63.5	95.0	92.0	180	230	F12	18.0
1000	340	349	364	138.5	109	171	69	104.5	81	32	140.0	172.5	164.0	240	230	F16	26.0

F02 BASE UNIT MODELS 063 TO 1000 - IMPERIAL (in / lb)

Model	A	B	H	a1	b1	b2	b3	c	d	e	h1	h2	h3	$\varnothing v$	x	F	lb
063	9.4	10.7	8.3	4.5	3.3	4.6	2.7	3.1	2.5	1.3	1.4	2.6	2.7	4.9	6.9	F07	17
125	9.4	10.7	9.1	4.5	3.3	4.6	2.7	3.1	2.5	1.3	2.1	3.4	3.4	4.9	6.9	F10	21
250	11.6	13.1	11.3	5.1	4.3	6.1	2.7	3.7	3.0	1.3	2.5	3.7	3.6	7.1	9.1	F12	36
500	11.6	13.1	11.3	5.1	4.3	6.1	2.7	3.7	3.0	1.3	2.5	3.7	3.6	7.1	9.1	F12	40
1000	13.4	13.7	14.3	5.5	4.3	6.7	2.7	4.1	3.2	1.3	5.5	6.8	6.5	9.4	9.1	F16	57

F02 ELECTRIC ACTUATORS

OVERALL DIMENSIONS - MODEL 2000

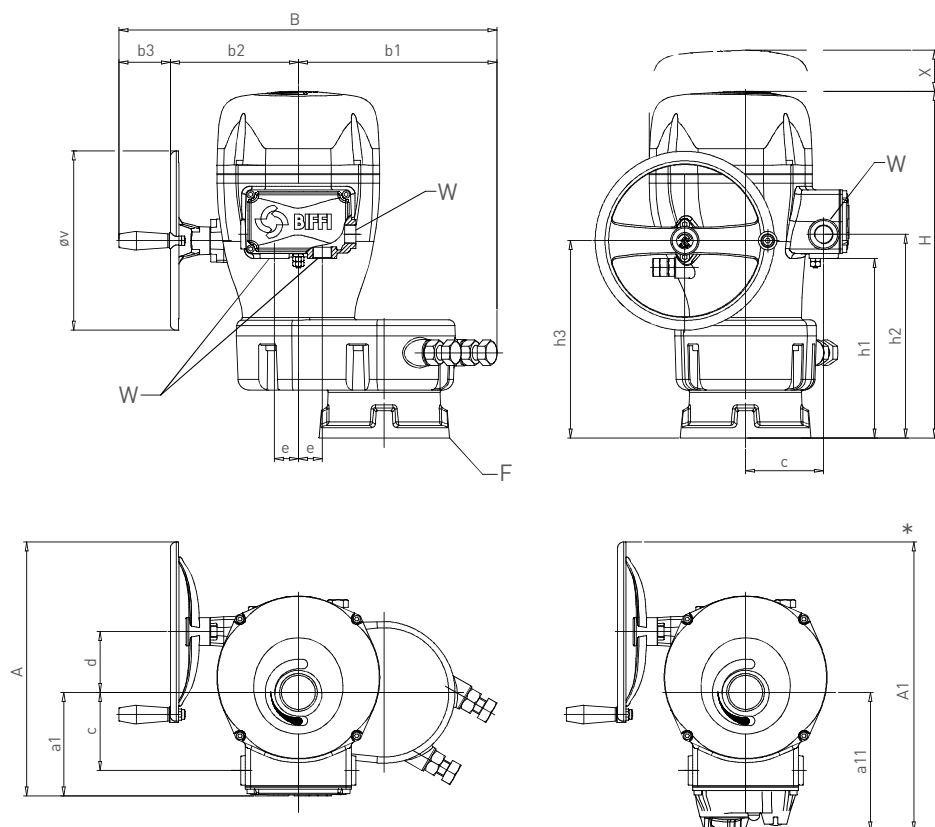

NOTES

W = Nr. 4 cable entries M25x1.5 acc. to ISO 724/965-1 (others available as special versions)

X = Space for cover removal

F = ISO 5211 Standard flange (others available)

F02 MODEL 2000 - METRIC (mm / kg)

Model	A	A1	B	H	a1	a11	b1	b2	b3	c	d	e	h1	h2	h3	øv	x	F	kg
2000	340	387	506	464	138.5	185.5	266	171	69	104.5	81	32	240	272.5	264	240	230	F10-F14	45.0
2000	340	387	506	464	138.5	185.5	266	171	69	104.5	81	32	240	272.5	264	240	230	F12-F16	46.5

F02 MODEL 2000 - IMPERIAL (in / lb)

Model	A	A1	B	H	a1	a11	b1	b2	b3	c	d	e	h1	h2	h3	øv	x	F	lb
2000	13.4	15.2	19.9	18.3	5.5	7.3	10.5	6.7	2.7	4.1	3.2	1.3	9.4	10.7	10.4	9.4	9.1	F10-F14	99
2000	13.4	15.2	19.9	18.3	5.5	7.3	10.5	6.7	2.7	4.1	3.2	1.3	9.4	10.7	10.4	9.4	9.1	F12-F16	103

F02 ELECTRIC ACTUATORS

OVERALL DIMENSIONS - OPTIONAL MODULES

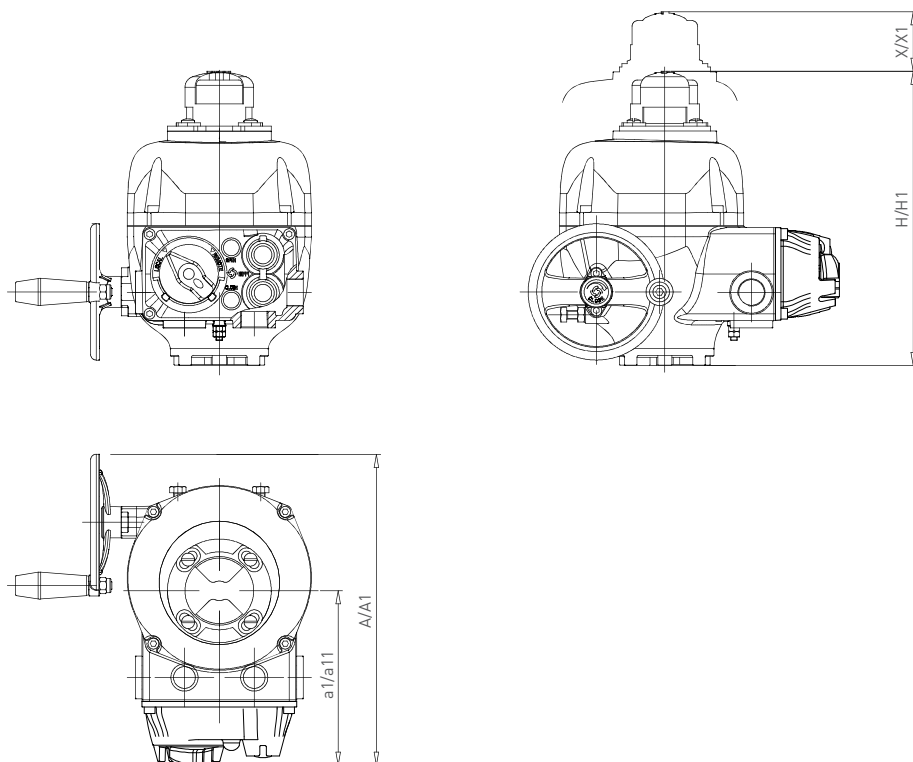

NOTES

1. Dimensions a1 and A are for the standard unit.
2. Dimensions a11 and A1 are for the standard unit plus a local interface option.
3. Dimensions H and X are for the standard unit.
4. Dimensions H1 and X1 are for the standard unit plus a Beacon type indicator.
5. X / X1 indicates the space for cover removal.
6. All other dimensions are as the standard unit.

F02 WITH OPTIONAL MODULES - METRIC (mm / kg)

Model	A	A1	a1	a11	H	H1	X	X1	kg ^[1]	kg ^[2]
063	239	285	114.0	160.0	210	270	175	265	7.5	8.0
125	239	285	114.0	160.0	230	290	175	265	9.5	10.0
250	295	341	129.0	175.0	287	347	230	330	15.5	16.0
500	295	341	129.0	175.0	287	347	230	330	17.0	17.5
1000	340	387	138.5	185.5	364	425	230	330	23.0	26.5

F02 WITH OPTIONAL MODULES - IMPERIAL (in / lb)

Model	A	A1	a1	a11	H	H1	X	X1	lb ^[1]	lb ^[2]
063	9.4	11.2	4.5	6.3	8.3	10.6	6.9	10.4	17	18
125	9.4	11.2	4.5	6.3	9.1	11.4	6.9	10.4	21	22
250	11.6	13.4	5.1	6.9	11.3	13.7	9.1	13.0	34	35
500	11.6	13.4	5.1	6.9	11.3	13.7	9.1	13.0	37	39
1000	13.4	15.2	5.5	7.3	14.3	16.7	9.1	13.0	51	58

1. Weight with Beacon option module
2. Weight with local interface module

F02 ELECTRIC ACTUATORS

OUTPUT DRIVE DIMENSIONS

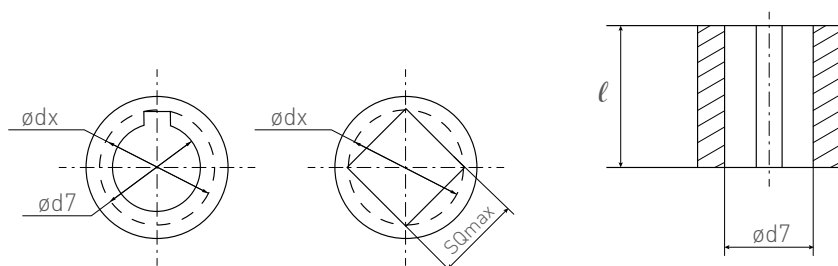

NOTES

1. Insert bush supplied with unmachined bore.
Largest bore can be supplied with solid piece bush.
2. Fixing bolts or rods supplied only on request.
3. dx: the maximum accepted diameter described by key, square or flat machining.
4. Position of the shaft with the valve closed.

OUTPUT DRIVE EN ISO 5211 STANDARD

Model	EN ISO 5211 flange	Output drive dimensions (mm/in)		Order code	Output drive dimensions (mm/in)				Order code
		Style square	l*		Flat	Bore diameter	Key	l*	
063	F05-F07	17/0.66	35/1.36	D4	14xD20 / 0.55xD0.78	-	-	35/1.36	E3
125	F07-F10	22/0.86	54/2.11	D5	22xD30 / 0.86xD1.18	-	-	54/2.10	E5
250	F07-F10-F12	22/0.86	54/2.11	D5	22xD30 / 0.86xD1.18	-	-	54/2.11	E5
500	F10-F12	27/1.05	62/2.42	D6	-	D35 / D1.37	10x8 / 0.39x0.31	62/2.42	E6
1000	F10-F14	36/1.41	40/1.56	D7	-	-	-	-	-
1000	F12-F16	36/1.41	40/1.56	DA	-	D50 / D1.96	14x9 / 0.55x0.35	80/3.12	E9
2000	F10-F14	36/1.41	40/1.56	D7	-	-	-	-	-
2000	F12-F16	36/1.41	40/1.56	DA	-	D50 / D1.96	14x9 / 0.55x0.35	80/3.12	E9

* Insert length (mm/in)

OUTPUT DRIVE K TYPE NON-ISO FLANGES

Model	K flange	Output drive dimensions (mm/in)				Order code
		Flat	Bore diameter	Key	l*	
063	44.45-82.55 / 1.75-3.25	12.7xD19 / 0.5xD0.74	-	-	35/1.36	U4
125	82.55 / 3.25	-	D28.7 / D1.12	6.35x6.35 / 0.25x0.25	54/2.11	U8
250	82.55-127 / 3.25-5	-	D28.7 / D1.12	6.35x6.35 / 0.25x0.25	54/2.11	U8
500	82.55-127 / 3.25-5	-	D41.38 / D1.62	9.53x9.53 / 0.375x0.375	62/2.42	UA
1000	127-165 / 5-6.5	-	D47.73 / D1.87	12.7x12.7 / 0.5x0.5	108/4.21	UC
2000	127-165 / 5-6.5	-	D47.73 / D1.87	12.7x12.7 / 0.5x0.5	108/4.21	UC

* Insert length (mm/in)

OUTPUT DRIVE NON STANDARD

Model	Output drive dimensions (mm/in)			
	$\varnothing d7$ max	$\varnothing dx$ max	SQ max	l*
063	17/0.66	23/0.90	17/0.66	35/1.36
125	22/0.89	29/1.13	22/0.89	54/2.11
250	28/1.09	37/1.44	27/1.05	54/2.11
500	28/1.09	37/1.44	27/1.05	62/2.42
1000	40/1.56	49/1.91	36/1.41	108/4.21
2000	40/1.56	49/1.91	36/1.41	108/4.21

* Insert length (mm/in)

F02 ELECTRIC ACTUATORS

WIRING DIAGRAM - BASE VERSION

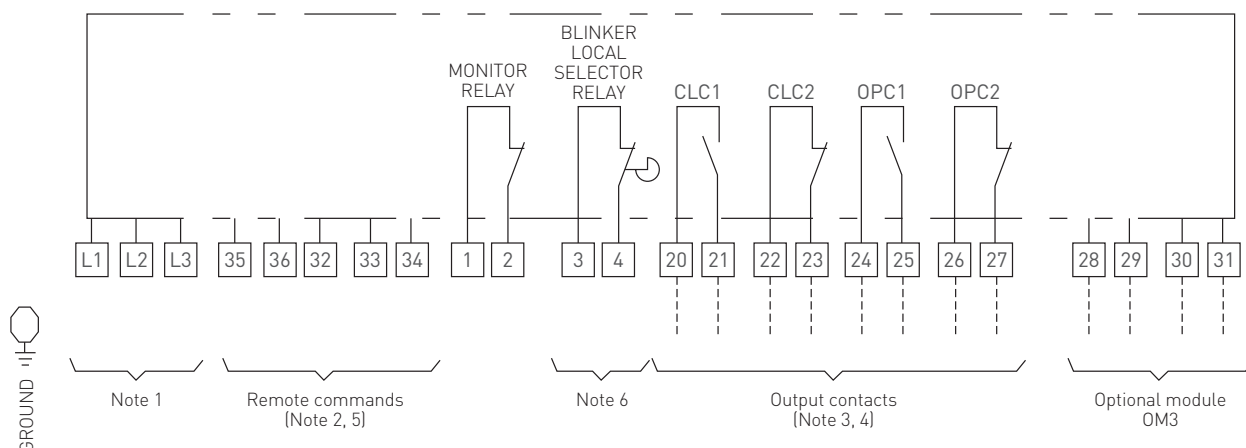

NOTES

- Power connection L1-L2 for V DC or V AC single phase motor supply from 24 V to 48 V or from 100 V to 240 V. Power connection L1-L2-L3 for 3 phase motor supply from 208 V to 575 V (check the actuator label for the correct voltage to be applied).
- Remote command options.

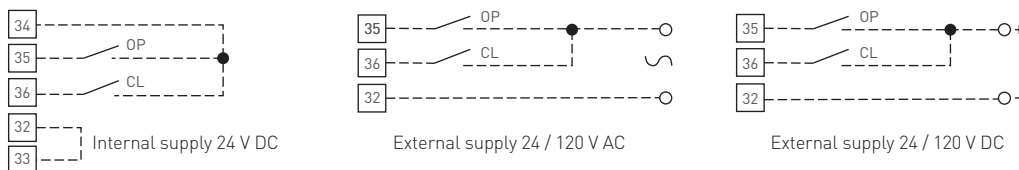

- Contacts shown in intermediate position CLC1-CLC2 end of travel signaling in closing. Contacts shown in intermediate position OPC1-OPC2 end of travel signaling in opening.
- Output contact rating 240 V AC / 5 A ; 30 V DC / 5 A ; 120 V DC / 0.5 A.
- Control command rating 24 to 120 V AC or DC.
- Blinker or local selector monitoring function (when OM3 is present) to be configured.

F02 ELECTRIC ACTUATORS

CURRENT ABSORPTION - SINGLE PHASE AND DC VOLTAGE

CURRENT ABSORPTION - SINGLE PHASE AND DC VOLTAGE

Model	Selected step	Operating time (secs/90°)	Current Absorption (A)											
			24 V AC	48 V AC	90 V AC	110 V AC	230 V AC	264 V AC	24 V DC	48 V DC	90 V DC	110 V DC	230 V DC	264 V DC
063	8	15	2.26	1.01	0.590	0.473	0.334	0.289	2.02	1.01	0.605	0.476	0.222	0.196
	6	28	1.60	0.84	0.405	0.334	0.253	0.217	1.53	0.75	0.415	0.343	0.158	0.138
	4	48	1.38	0.73	0.317	0.265	0.209	0.176	1.30	0.64	0.318	0.260	0.120	0.106
125	8	15	4.20	1.70	0.980	0.810	0.430	0.420	4.50	1.81	1.040	0.820	0.390	0.340
	6	28	2.60	1.28	0.780	0.630	0.370	0.340	2.65	1.27	0.810	0.640	0.300	0.260
	4	48	2.04	1.00	0.680	0.560	0.340	0.290	2.10	0.96	0.720	0.570	0.270	0.220
250	8	15	10.30	4.90	2.440	1.970	0.920	0.800	9.70	4.80	2.520	1.950	0.900	0.780
	6	28	8.20	3.80	1.650	1.350	0.640	0.570	7.20	3.60	1.650	1.320	0.630	0.540
	4	48	6.40	3.30	1.440	1.170	0.560	0.500	6.80	3.20	1.460	1.140	0.540	0.470
500	8	15	14.50	6.80	3.200	2.520	1.150	1.000	14.00	7.00	3.220	2.530	1.120	0.980
	6	28	9.50	4.60	1.900	1.550	0.760	0.670	9.30	4.50	1.920	1.540	0.720	0.620
	4	48	7.00	3.40	1.550	1.240	0.600	0.530	7.10	3.40	1.510	1.240	0.580	0.500
1000	8	24	14.50	6.80	3.200	2.520	1.150	1.000	14.00	7.00	3.220	2.530	1.120	0.980
	6	45	9.50	4.60	1.900	1.550	0.760	0.670	9.30	4.50	1.920	1.540	0.720	0.620
	4	80	7.00	3.40	1.550	1.240	0.600	0.530	7.10	3.40	1.510	1.240	0.580	0.500
2000	8	53	14.50	6.80	3.200	2.520	1.150	1.000	14.00	7.00	3.220	2.530	1.120	0.980
	6	100	9.50	4.60	1.900	1.550	0.760	0.670	9.30	4.50	1.920	1.540	0.720	0.620
	4	180	7.00	3.40	1.550	1.240	0.600	0.530	7.10	3.40	1.510	1.240	0.580	0.500

F02 ELECTRIC ACTUATORS
 CURRENT ABSORPTION - THREE PHASE VOLTAGE

CURRENT ABSORPTION - THREE PHASE VOLTAGE

Model	Selected step	Secs/90°	Current absorption (A)						
			208 V AC	240 V AC	380 V AC	400 V AC	480 V AC	500 V AC	575 V AC
063	8	15	0.226			0.176			0.107
	6	28	0.165			0.101			0.080
	4	48	0.132			0.083			0.057
125	8	15	0.344			0.227			0.171
	6	28	0.295			0.180			0.143
	4	48	0.245			0.155			0.125
250	8	15	0.800	0.73	0.52		0.49	0.37	0.340
	6	28	0.590	0.56	0.41		0.35	0.29	0.280
	4	48	0.530	0.50	0.37		0.30	0.27	0.250
500	8	15	1.073	0.97	0.65		0.58	0.46	0.430
	6	28	0.720	0.64	0.47		0.39	0.32	0.310
	4	48	0.590	0.55	0.41		0.32	0.29	0.280
1000	8	24	1.073	0.97	0.65		0.58	0.46	0.430
	6	45	0.720	0.64	0.47		0.39	0.32	0.310
	4	80	0.590	0.55	0.41		0.32	0.29	0.280
2000	8	53	1.073	0.97	0.65		0.58	0.46	0.430
	6	100	0.720	0.64	0.47		0.39	0.32	0.310
	4	180	0.590	0.55	0.41		0.32	0.29	0.280

F02 ELECTRIC ACTUATORS

ORDERING INFORMATION

SELECTION GUIDE

Product							
BPD	ISO 5211 with double star insert						
BPE	ISO 5211 with flat or key insert						
BPU	Non-ISO flange						
BPB	ISO 5211 flange - insert not machined						
BPK	Key non-ISO flange - insert not machined						
BFD	[NPT] US version ISO 5211 flange with ISO insert, 4x 1"NPT entries						
Models							
063	Model 063						
125	Model 125						
250	Model 250						
500	Model 500						
1K0	Model 1000						
2K0	Model 2000						
06B	Model 063 with Beacon						
12B	Model 125 with Beacon						
25B	Model 250 with Beacon						
50B	Model 500 with Beacon						
1KB	Model 1000 with Beacon						
2KB	Model 2000 with Beacon						
Voltage							
LV	1-phase voltage 24 to 48 V DC/V AC						
HV	1-phase voltage 100 to 240 V DC/V AC						
3A	3-phases from 208 to 240 V AC						
3B	3-phases from 380 to 480 V AC						
3C	3-phases from 500 to 575 V AC						
Speed/Duty							
PD	Standard speed range and standard duties for model 063 to 500						
PE	Standard speed range and standard duties for model 1000						
PF	Standard speed range and standard duties for model 2000						
Optional modules							
00	No optional modules						
P1	OM1						
PA	OM1/OM3/Bluetooth						
P6	OM1/OM3						
P7	OM1/Bluetooth						
P3	OM3						
5P	OM9/Bluetooth						
6P	OM9/OM3/Bluetooth						
5D	OM11/Bluetooth						
6D	OM11/OM3/Bluetooth						
PG	OM13						
Approvals/Protections							
0	Standard protection NEMA 4/4X/6 (IP66/68M) - CSA certificate T°amb from -40°C to +60°C / -40°F to +140°F						
2	Standard protection NEMA 4/4X/6 (IP66/68M) T°amb from -25°C to +70°C / -13°F to +158°F						
3	Standard protection NEMA 4/4X/6 (IP66/68M) T°amb from -40°C to +70°C / -40°F to +158°F						
4	Explosionproof IP66/68 (NEMA 4/4X/6) + Ex d e IIB T5 Gb - EX tb IIC T100°C Db T°amb -20°C to +65°C / -4°F to 149°F [prefix c for model 2000]						
9	Explosionproof IP66/68 (NEMA 4/4X/6) + Ex d e IIB T5 Gb - EX tb IIIC T100°C Db T°amb from -40°C to +65°C / -40°F to 149°F [prefix c for model 2000]						
Flange/Insert							
00	No flange insert						
B4	Model 063 flange ISO 5211/F05/F07 - insert not machined (BPB)						
B5	Model 125 flange ISO 5211/F07/F10 - insert not machined (BPB)						
B5	Model 250 flange ISO 5211/F07/F10/F12 - insert not machined (BPB)						
B6	Model 500 flange ISO 5211/F10/F12 - insert not machined (BPB)						
B7	Model 1000-2000 flange ISO 5211/F10/F14 - insert not machined (BPB)						
BA	Model 1000-2000 flange ISO 5211/F12/F16 - insert not machined (BPB)						
D4	Model 063 ISO 5211 (BPD)						
D5	Models 125/250 ISO 5211 (BPD)						
D6	Model 500 ISO 5211 (BPD)						
D7	Models 1000/2000 F10 to F14 ISO 5211 (BPD)						
DA	Models 1000/2000 F12 to F16 ISO 5211 (BPD)						
E3	Model 063 ISO 5211 (BPE)						
E5	Models 125/250 ISO 5211 (BPE)						
E6	Model 500 ISO 5211 (BPE)						
E9	Models 1000/2000 F12 to 16 ISO 5211 (BPE)						
K4	Model 063 flange key 44.45-82.6 - insert not machined (BPK)						
K8	Model 125 flange key 82.6 - insert not machined (BPK)						
K8	Model 250 flange key 82.6-127 - insert not machined (BPK)						
KA	Model 500 flange key 82.6-127 - insert not machined (BPK)						
KC	Model 1000-2000 flange key 127-165 - insert not machined (BPK)						
U4	Model 063 non-ISO (BPU)						
U8	Models 125/250 non-ISO (BPU)						
UA	Model 500 non-ISO (BPU)						
UC	Models 1000/2000 non-ISO (BPU)						
BPD	063	LV	PD	P1	2	D4	= Model number BPD063LVPDP12D4