

Fisher™ 9500 Butterfly Control Valve

The Fisher 9500 butterfly valve is a fully lined valve for use with corrosive fluids and where tight shutoff is required. The nitrile or PTFE liner totally isolates the valve body and shaft from the process fluid and maintains excellent shutoff at pressure drops to 15.2 bar (220 psi), and temperatures to 121°C (250°F).

The 9500 valve is available in NPS 2 through 12 and is compatible with ASME B16.1 CL125B, with ASME B16.34 CL150 and CL300, or with DIN flanges. These valves are furnished with splined shafts for use with power actuators, with a Fisher 1077 manual actuator, or with a 1078 declutchable manual actuator (see figure 1).



Fisher 9500 Valve with 1052 Actuator and FIELDVUE™
DVC6200 Digital Valve Controller



Fisher 9500 Valve with 1066SR Actuator

Specifications

Valve Sizes

NPS ■ 2, ■ 3, ■ 4, ■ 6, ■ 8, ■ 10, or ■ 12

Valve Style

Flangeless (wafer-type) valve to be installed between two pipe flanges

End Connection Styles

Flangeless (wafer-style) valve mates with CL125 flat-face flanges per ASME B16.1, CL150 and CL300 raised-face flanges per ASME B16.34, or DIN flanges as shown in table 2

Maximum Allowable Inlet Pressure⁽¹⁾

Maximum material temperature capabilities are limited as shown in table 3. The material maximum allowable shutoff or flowing pressure drop limits are shown in tables 1 and 4. Valve bodies are consistent with applicable pressure/temperature ratings for ■ CL125B per ASME B16.1, or ■ CL150 and CL300 per ASME B16.34.

Vacuum Service

Valves suitable are for vacuum service to approximately 10⁻⁷ mm Hg absolute (3.4 x 10⁻¹² mbar, absolute)

Maximum Allowable Pressure Drop⁽¹⁾

Maximum Allowable Shutoff: See table 1
Maximum Flowing Pressure Drops: See table 4

Construction Materials

Valve body: ■ Cast iron, ■ carbon steel, or ■ S31600 [316 stainless steel (SST)]
Disk and Liner: See table 3
Shaft and Taper Pins: S17400 (17-4PH SST) standard or S20910
Thrust Bearing: All cast iron or steel valves use a PTFE/bronze in a carbon steel shell; NPS 2 through 6 SST valves use a PTFE-liner in a S31600 shell; NPS 8 through 12 SST valves use a PTFE-liner in a fiberglass shell
Thrust Bearing Sleeves: Stainless steel
Shaft-Seal Thrust Plate: ■ Plated carbon steel (standard) or ■ S31600 SST
Thrust-Plate Cap Screws: Steel

Material Temperature Capabilities⁽¹⁾

See table 3

Flow Characteristic

Conventional Disk: Approximately equal percentage through 60 degrees of disk rotation
FISHTAIL™ Disk: Approximately equal percentage through 90 degrees of disk rotation

Flow Direction

Conventional Disk: Bidirectional
FISHTAIL Disk: Forward flow -The tail of the disk opens into the downstream end of the valve

Flow Coefficients

See Fisher Catalog 12

Flow Coefficient Ratio⁽²⁾

Conventional Disk: approximately 33 to 1 for a 0 to 60 degree disk rotation
FISHTAIL Disk: 100 to 1 or greater for a 0 to 90 degree disk rotation

Disk Rotation

Conventional Disk:
On/Off Service: ■ 0 to 60 or ■ 0 to 90 degrees
Throttling Service: 0 to 60 degrees

FISHTAIL Disk: 0 to 60 or 0 to 90 degrees for on/off or throttling

Noise Levels

Refer to Catalog 12 for sound pressure level prediction

Shutoff Classification per ANSI/FCI 70-2 and IEC 60534-4

Nitrile or PTFE Liner: Class VI

Actuator/Valve Action

Field-reversible between ■ push-down-to-open (extending actuator stem opens disk) or ■ push-down-to-close (extending actuator stem closes disk)

(continued)

Specifications (continued)

Actuator Mounting

Mounting configurations are as follows: Actuator can be ■ perpendicular to (standard) or ■ parallel with pipeline with actuator to ■ right (standard) or ■ left of valve body (when viewed from valve inlet). With perpendicular mounting in horizontal pipeline, actuator can extend ■ above (standard) or ■ below pipeline. With parallel mounting, actuator can extend ■ upstream or ■ downstream of valve

Mating Flange Capabilities

All sizes compatible with weld-neck flanges; also see the Installation section for slip-on flanges

Face-to-Face Dimensions

Dimensions meet MSS SP-67 specifications for face-to-face dimensions of flangeless valves

Valve Shaft Diameters

See figure 4 and table 5

Approximate Weights

See figure 4 and table 5

Options

Three-Way Valve: For converging or diverging service. Consists of two 9500 valves and a single actuator mounted on a pipe tee. Actuator operates both valves through tandem linkage. Contact your [Emerson sales office](#) for sizing information

Flange Adapters: Provide additional liner support for use with ■ slip-on flanges and valve bodies NPS 6 and larger, ■ flexible flanges, ■ flanges having inside diameters less than or greater than standard weld-neck flanges, or for ■ dead-end service (valve installed at end of pipe run)

Valve body for mating between CL300 flanges.

Manual Actuator: Fisher 1077 manual handwheel rotary actuator, or the 1078 declutchable manual actuator, see figure 1

1. The pressure/temperature limits in this bulletin and any other applicable standard or code limitation should not be exceeded.
2. Ratio of maximum flow coefficient to minimum usable flow coefficient.

Figure 1. Fisher 1077 and 1078 Manual Rotary Actuators



W4579

1077 MANUAL ACTUATOR



W4867

1078 DECLUTCHABLE MANUAL ACTUATOR

Table 1. Maximum Allowable Shutoff Pressure Drops⁽¹⁾

VALVE SIZE, NPS	MAXIMUM ALLOWABLE SHUTOFF PRESSURE DROPS							
	Liquid Service				Gaseous Service			
	PTFE Liner		Nitrile Liner		PTFE Liner		Nitrile Liner	
	Cast Iron Valve Material	Steel or Stainless Steel Valve Material	Cast Iron Valve Material	Steel or Stainless Steel Valve Material	Cast Iron Valve Material	Steel or Stainless Steel Valve Material	Cast Iron Valve Material	Steel or Stainless Steel Valve Material
Bar								
2, 3, and 4	12.1	15.2	12.1	15.2	12.1	15.2	12.1	15.2
6, 8, 10, and 12	12.1	15.2	10.4	10.4	12.1	15.2	10.4	10.4
Psi								
2, 3, and 4	175	220	175	220	175	220	175	220
6, 8, 10, and 12	175	220	150	150	175	220	150	150

1. The values in this table were determined using S17400 (17-4PH SST) shaft and taper pins. If other materials are used, you must refer to Catalog 14 Pages (section D) for adjustment percentages.

Features

- **Versatile**—Conventional disks are available for bidirectional, on/off or throttling control. Valves are available with S31600 [316 stainless steel (SST)] FISHTAIL disk for on/off or throttling control (see figure 2). The disks can be obtained in a variety of alloy materials for additional corrosion resistance.
- **Economical**—Valve body and shafts are isolated from process fluid, allowing use of cast iron valve bodies for corrosive applications.
- **Adjustable Shaft Seal**—Liner is directed against a flat disk hub by a thrust bearing, creating a seal between the liner and the disk as shown in figure 3. Seals are adjusted as necessary to provide leak control.
- **Flange Gasket Not Required**—Partial O-ring (figure 3) is molded as part of the liner. It seals against

mating flanges which eliminate the need for flange gaskets.

- **Excellent Flow Control**—The conventional disk is approximately equal percentage flow characteristic through 60 degrees of its rotation. The FISHTAIL disk has an approximate equal percentage flow characteristic through a full 90 degrees of disk rotation.
- **Operational Economy**—The FISHTAIL disk reduces dynamic torque, which allows the use of a smaller actuator size for a given application.
- **Minimum Maintenance**—No lubrication is required, and no packing or flange gaskets to replace. Shaft seal is easy to adjust. Removing valve components and changing the valve action is accomplished without complete disassembly. Field-replaceable slip-in liner minimizes downtime and reduces maintenance costs.

Table 2. Mating Flange Compatibility

VALVE SIZE, NPS	CAST IRON		STEEL AND STAINLESS STEEL	
	ASME	DIN	ASME	DIN
2, 3	CL125B	PN10	CL150	PN16
4	CL125B	---	CL150	PN16
6, 8, 10	CL125B	PN10	CL150	PN16
12	CL125B	---	CL150	PN16

Table 3. Disk and Liner Materials

DISK STYLE	DISK MATERIAL	LINER MATERIAL	TEMPERATURE RANGE	
			°C	°F
Conventional	Aluminum bronze	PTFE-lined elastomer molded to aluminum backup ring	-18 to 121	0 to 250
		Nitrile molded to hard rubber backup ring	-7 to 93	20 to 200
FISHTAIL	S31600 stainless steel	PTFE-lined elastomer molded to aluminum backup ring	-18 to 121	0 to 250

Table 4. Maximum Allowable Flowing Pressure Drops Due to Strength Capabilities of Valve Body Components

VALVE SIZE, NPS	MAXIMUM ALLOWABLE FLOWING PRESSURE DROPS			
	Conventional Disk		FISHTAIL Disk	
	At 60 Degrees Rotation	At 90 Degrees Rotation	At 60 Degrees Rotation	At 90 Degrees Rotation
Bar				
2	12.1 ⁽¹⁾ 15.2 ⁽²⁾	8.5	12.1 ⁽¹⁾ 15.2 ⁽²⁾	12.1 ⁽¹⁾ 15.2 ⁽²⁾
3	12.1 ⁽¹⁾ 15.2 ⁽²⁾	5.0	12.1 ⁽¹⁾ 15.2 ⁽²⁾	12.1 ⁽¹⁾ 15.2 ⁽²⁾
4	6.6	2.1	11.9	6.8
6	3.4	1.1	5.9	2.9
8	3.4	1.1	5.9	2.9
10	1.7	0.6	2.8	1.2
12	2.0	0.6	3.2	1.3
Psi				
2	175 ⁽¹⁾ 220 ⁽²⁾	124	175 ⁽¹⁾ 220 ⁽²⁾	175 ⁽¹⁾ 220 ⁽²⁾
3	175 ⁽¹⁾ 220 ⁽²⁾	73	175 ⁽¹⁾ 220 ⁽²⁾	175 ⁽¹⁾ 220 ⁽²⁾
4	96	31	173	99
6	50	16	85	42
8	50	16	85	42
10	25	8	41	17
12	29	9	47	19

1. For cast iron valve bodies.
2. For steel or stainless steel valve bodies.

Figure 2. Sectional Views of Fisher 9500 Valves

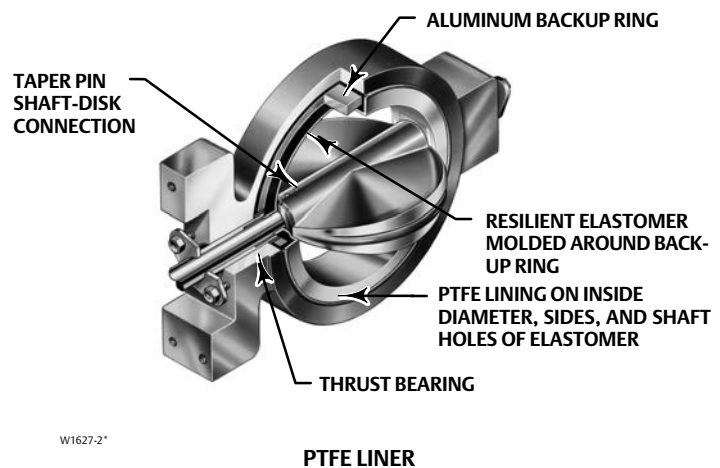
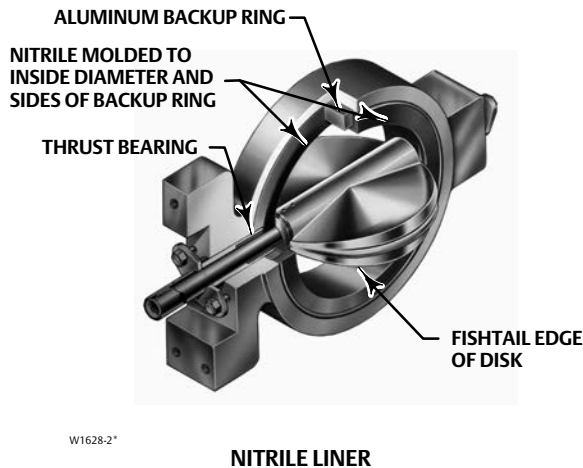
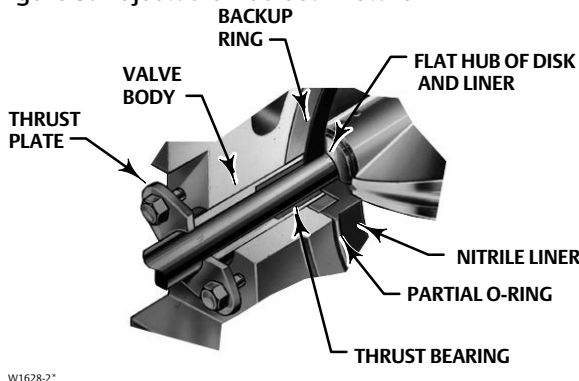

Figure 3. Adjustable Hub Seal Details



in the valve body. Care must be taken during installation to assure that the pipe flanges are properly supported to avoid liner damage, flange joint leakage, and problems with valve operation. Flexible, plastic flanges; fiberglass, slip-on flanges; or weld-neck flanges with other than standard inside diameters may not provide adequate support for the liner. The use of flange adapters can overcome flange support problems during installation. Whenever a flange adapter is used, a standard flange gasket must be installed between the line flange and flange adapter. Do not use a flange gasket between the valve and flange adapter. The partial O-ring on the liner acts as the flange gasket and any additional gasket here will damage the liner.

Installation

Please refer to the Fisher 9500 instruction manual, ([D100380X012](#)) for additional / complete installation and maintenance instructions.

These valves may be installed in any position. For conventional disks, flow may be in either direction. For FISHTAIL disks, the FISHTAIL edge of the disks must be located in to the downstream end of the valve (see figure 2).

The liner overlaps the valve face producing the partial O-ring shown in figure 3. It acts as the flange gasket. Improper use of additional gasketing materials may damage the valve liner.

The simplicity of the 9500 valve design is achieved by relying on mating pipe flanges to retain the slip-in liner

Excessive line bolt load on flexible mating flanges can warp the liner. Also, failing to support the liner at the inside diameter can warp the liner. The use of flange adapters can overcome bolt load problems during installation.

Slip-on pipe flanges may be used with NPS 2, 3, or 4 9500 valves. Valves NPS 6 and larger will require flange adapters for complete liner support.

The maximum and minimum allowable inside diameter of mating flanges or adjacent pipes are given in figure 4 and table 5. Flanges or pipes with inside diameters smaller than the minimum shown may interfere with the opening of the disk. Flanges or pipes with an inside diameter larger than the maximum shown may not be in full contact with the liner. Flange adapters are needed in either case, to provide disk clearance or to fully contact the liner.

Table 5. Dimensions

VALVE SIZE NPS	A		B		D	E	F	Q	S (Shaft Diameter)	T	U	W	ALLOWABLE MATING FLANGE / PIPEBORE		APPROXIMATE WEIGHT	
	CL125 / 150	CL300	CL125 / 150	CL300			Splined Valve Shaft						Min	Max		
mm																kg
2	105	111	108	114	42.00	103	187	44	12.7	117	---	3/8-16	31	63	9.4	
3	119	129	127	137	45.00	133	211	48	15.9	146	32	3/8-16	64	92	11	
4	116	151	146	159	51.00	171	211	54	15.9	146	32	3/8-16	89	117	14	
6	167	186	171	191	54.00	220	214	57	19.1	146	32	3/8-16	145	171 ⁽¹⁾	20	
8	198	217	203	222	61.00	276	214	64	25.4	146	32	3/8-16	196	222 ⁽¹⁾	27	
10	230	249	235	254	69.00	335	214	71	25.4	146	32	3/8-16	246	273 ⁽¹⁾	32	
12	268	287	273	292	78.00	405	208	81	31.8	210	51	5/8-11	297	330 ⁽¹⁾	54	
Inches																Pounds
2	4.13	4.38	4.25	4.50	1.64	4.06	7.38	1.75	0.50	4.62	---	3/8-16	1.20	2.50	20	
3	4.69	50.6	5.00	5.38	1.76	5.25	8.31	1.88	0.62	5.75	1.25	3/8-16	2.50	3.62	25	
4	5.44	5.94	5.75	6.25	2.02	6.75	8.31	2.12	0.62	5.75	1.25	3/8-16	3.50	4.62	30	
6	6.56	7.31	6.75	7.50	2.14	8.68	8.44	2.25	0.75	5.75	1.25	3/8-16	5.70	6.75 ⁽¹⁾	46	
8	7.81	8.56	8.00	8.75	2.39	10.88	8.44	2.50	1.00	5.75	1.25	3/8-16	7.70	8.75 ⁽¹⁾	60	
10	9.06	9.81	9.25	10.00	2.70	13.19	8.44	2.81	1.00	5.75	1.25	3/8-16	9.70	10.75 ⁽¹⁾	70	
12	10.56	11.31	10.75	11.50	3.08	15.94	8.19	3.19	1.25	8.25	2.00	5/8-11	11.70	13.00 ⁽¹⁾	119	

1. These size valves when installed between slip-on flanges require flange adapters for complete support.

Figure 4. Dimensions (also see table 5)

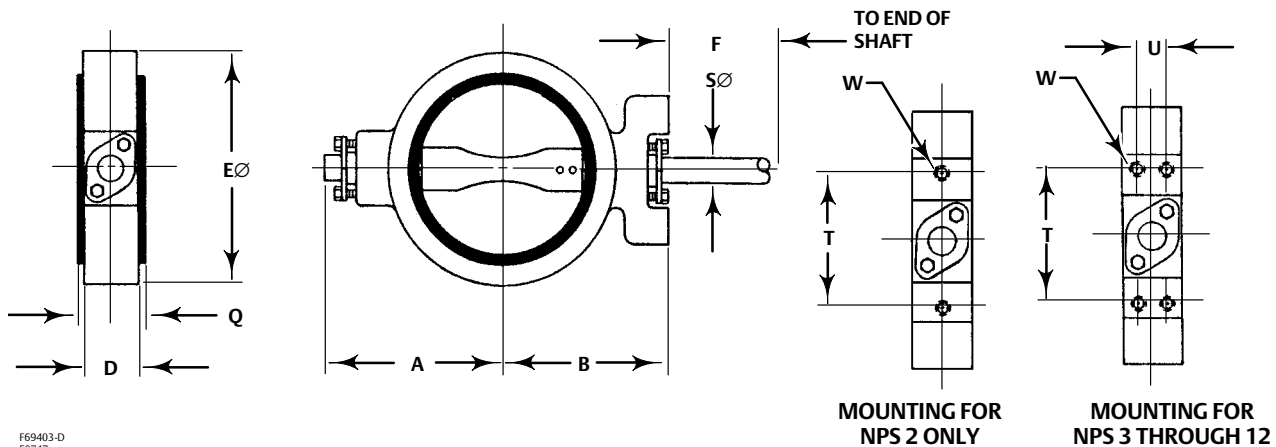

F69403-D
E0747

NOTE:
FOR NON-CODE MATERIAL THE ASME CLASS REPRESENTS DIMENSIONS NOT PRESSURE TEMPERATURE RATING.
DISK CHORDAL SWING DIA. AT VALVE FACE IS "M". PLEASE VERIFY CLEARANCE WITH PIPING.

Product Bulletin

51.4:9500
February 2019

9500 Valve
D100058X012

Neither Emerson, Emerson Automation Solutions, nor any of their affiliated entities assumes responsibility for the selection, use or maintenance of any product. Responsibility for proper selection, use, and maintenance of any product remains solely with the purchaser and end user.

Fisher, FIELDVUE, and FISHTAIL are marks owned by one of the companies in the Emerson Automation Solutions business unit of Emerson Electric Co. Emerson Automation Solutions, Emerson, and the Emerson logo are trademarks and service marks of Emerson Electric Co. All other marks are the property of their respective owners.

The contents of this publication are presented for informational purposes only, and while every effort has been made to ensure their accuracy, they are not to be construed as warranties or guarantees, express or implied, regarding the products or services described herein or their use or applicability. All sales are governed by our terms and conditions, which are available upon request. We reserve the right to modify or improve the designs or specifications of such products at any time without notice.

Emerson Automation Solutions
Marshalltown, Iowa 50158 USA
Sorocaba, 18087 Brazil
Cernay 68700 France
Dubai, United Arab Emirates
Singapore 128461 Singapore

www.Fisher.com

