

- **Industry-specific design**
  - suitable for all applications found in the water and waste water industries
- **Widest flow range, highest accuracy**
  - diameters from 15mm to 2200mm (0.5 to 84 in.)
- **Submersible sensor**
  - suitable for flooded chambers and pits
- **Buriable sensor**
  - eliminates chambers and ensures fast, low-cost installation
- **Hazardous area approvals**
  - FM, CSA, ATEX
  - ideal for waste water treatment works
- **Built-in earthing (grounding) electrode**
  - eliminates the need for earthing (grounding) flanges
- **2-year warranty as standard**
  - high-quality product guarantees reliable maintenance-free operation
- **CalMaster compatible**
  - in situ verification of flow meter calibration
- **Remote Communications**
  - including Profibus DP v0



**MagMaster – bringing unsurpassed flowmetering performance to the Water and Waste Water industries**

## Setting the Standard

Designed specifically to target the diverse applications found in the supply and treatment of both potable and waste water, MagMaster sets new levels of accuracy, reliability and low cost of ownership.

MagMaster's ground-breaking design guarantees long-term calibration stability, coupled with the wide range of sizes, 15 to 2600mm (0.5 to 102 in.), choice of lining and electrode material quickly established MagMaster as the de facto industry standard electromagnetic flow meter.

## Class-leading Flow Performance

The combination of sensors with ultra-linear magnetics, proven technology, signal processing and sensor drive results in unsurpassed accuracy and an operable flow range of 1500:1. MagMaster's class-leading performance ensures reliable and accurate measurement over the widely varying flow rates, including minimal night flows, which occur in typical water and waste water systems.

## Assured Quality

MagMaster is designed and manufactured in accordance with international quality procedures (ISO 9001) and all flowmeters are calibrated on nationally-traceable calibration rigs to provide the end user with complete assurance of both quality and performance of the meter.

## Calibration Verification

CalMaster is the world's first in situ calibration verification system. The system allows the calibration of MagMaster electromagnetic flow meters to be verified without the need for 'wet calibration'. The complex series of tests automatically performed by CalMaster is completed and a certificate produced without costly excavation of the sensor or disruption to the water supply. A complete solution to the regulatory requirement for routine verification and traceability of electromagnetic flow meters.

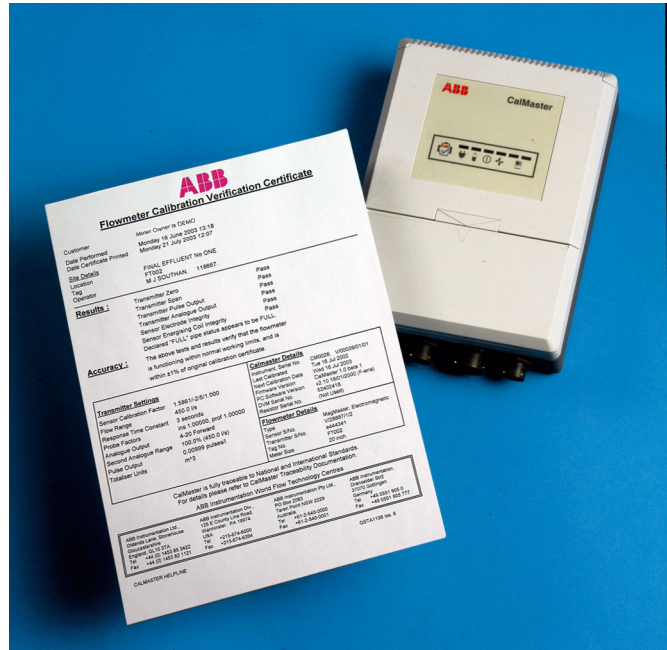

For further information on CalMaster refer to the brochure PB/CALMASTER



ABB operated national and internationally accredited flow calibration facilities in the UK, USA, Australia, Germany and India.

## Electronic Display Unit

- Comprehensive display
- Forward, reverse and net totals
- 4 digital outputs: forward pulse, reverse pulse, alarm 1 and alarm 2
- 2 analog outputs (output 2 optional)
- Communications: serial data (RS232), HART and Profibus DP v0

MagMaster is available with integral or remote transmitters, configuration is achieved either with a configurator or via the optional integral keypad. The software features multi-level password protection to prevent unauthorized configuration changes. In the 2-line display only variant, display data can only be changed using a magnetic wand, no operational parameters can be changed without the use of a configurator and appropriate passwords.



Wallmount Version

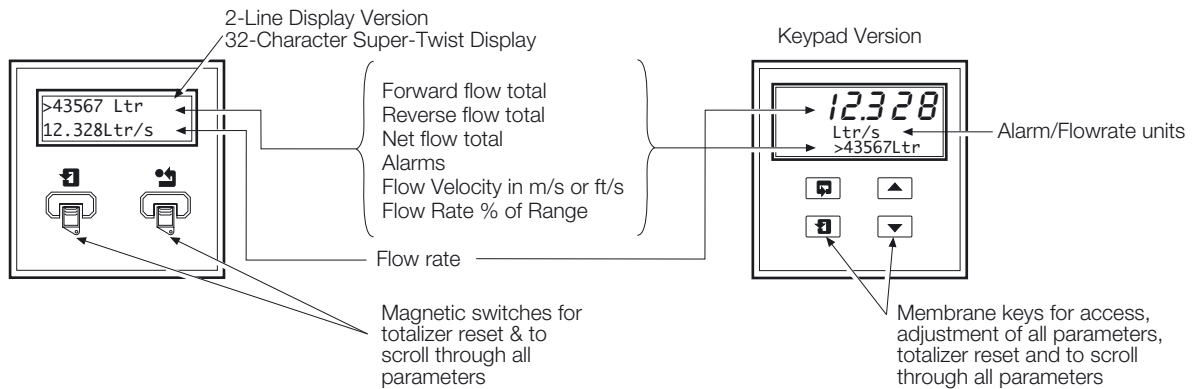

## Programming Options

- Local hand-held configurator (for example Psion Workabout)
- Integral keypad
- HART
- Personal computer

## Easy, Low-cost Installation

MagMaster sensors' rugged and robust construction ensure a long, maintenance-free life under the arduous conditions experienced in the water and waste water industry. The sensors are fully submersible, meeting the requirements of IP68 (NEMA6P) enabling installation in flooded chambers or metering pits.

MagMaster sensors in all sizes are buriable. Installation merely involves excavating to the underground pipe, fitting the sensor, cabling back to the transmitter and then backfilling the hole. No metering chambers or pits are required so the installation is simple, fast and low cost.



*Underground Installation of MagMaster*

## International Approvals

Alternative versions of MagMaster are available for general locations with FM Approval/CSA Certification and for Hazardous Area locations to ATEX, FM and CSA Standards. A brief summary of these Hazardous Area versions is given below, covering the safety designation inside the pipe. No external safety barriers are required.

SENSOR	INSIDE PIPE	TRANSMITTER LOCATION
FM & CSA HAZARDOUS AREA APPROVAL – CLASS 1, DIV. 2, GROUPS A B C D		
FM APPROVED	INTRINSICALLY SAFE ELECTRODES	REMOTE ONLY IN HAZARDOUS AREA
CSA CERTIFIED		REMOTE ONLY IN HAZARDOUS AREA
CSA CERTIFIED	NON INCENDIVE	INTEGRAL AND REMOTE IN HAZARDOUS AREA
ATEX – II 2 (I) G EEx e m ia IIC T4		
ZONE 1	ZONE 0	REMOTE TRANSMITTER IN SAFE AREA

## Specification

### Sensor

#### Sizes

Sizes mm (in.)	Flow Range	
	Minimum	Maximum*
	m <sup>3</sup> /h (US g/min)	m <sup>3</sup> /h (US g/min)
15 (0.6)	0.005 (0.021)	6 (28)
20 (0.8)	0.009 (0.038)	11 (50)
25 (1)	0.014 (0.059)	17 (77)
40 (1.6)	0.035 (0.15)	45 (197)
50 (2)	0.053 (0.23)	71 (311)
65 (2.5)	0.089 (0.40)	119 (525)
80 (3)	0.136 (0.59)	181 (796)
100 (4)	0.21 (0.94)	283 (1243)
150 (6)	0.47 (2.10)	640 (2797)
200 (8)	0.84 (3.73)	1130 (4974)
250 (10)	1.32 (5.83)	1770 (7771)
300 (12)	1.91 (8.4)	2540 (11190)
350 (14)	2.60 (11)	3460 (15230)
400 (16)	3.39 (15)	4520 (19890)
450 (18)	4.29 (19)	5730 (25180)
500 (20)	5.3 (23)	7070 (31090)
600 (24)	7.6 (33)	10180 (44760)
700 (28)	14 (46)	13850 (60920)
760 (30)	16 (52)	15900 (69930)
800 (31)	18 (60)	18100 (79560)
900 (35)	23 (75)	22900 (100700)
1000 (39)	28 (93)	28300 (124300)
1050 (41)	31 (112)	34200 (150400)
1200 (47)	41 (134)	40700 (179000)
1400 (55)	55 (182)	55400 (243700)
1500 (59)	64 (208)	63600 (279700)
1600 (63)	72 (238)	72400 (318300)
1800 (71)	92 (302)	91600 (402800)
2000 (79)	113 (372)	113100 (497400)
2200 (87)	136 (451)	137000 (602000)

\* Based on 10ms<sup>-1</sup> (33fts<sup>-1</sup>), but instrument capability in excess of 15ms<sup>-1</sup> (50fts<sup>-1</sup>)

#### Accuracy (under forward flow reference conditions)

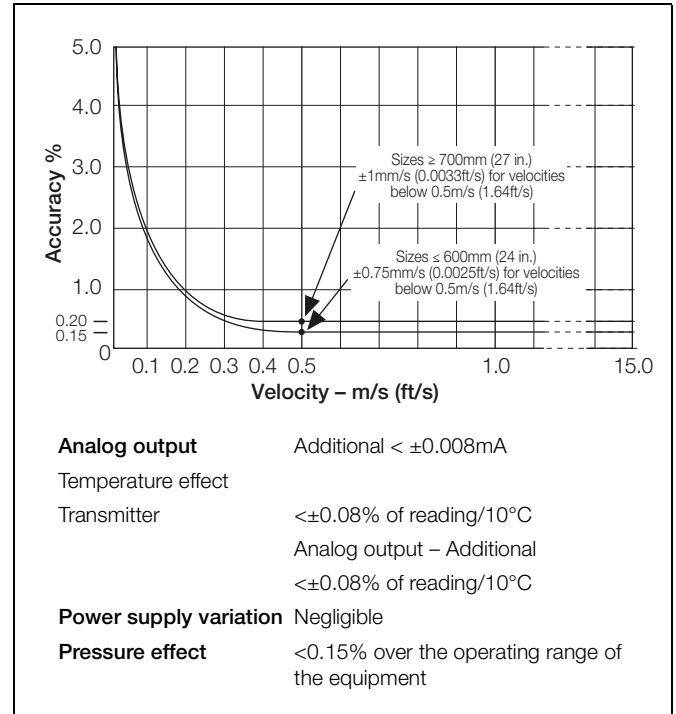

## Wetted Material

### Lining

Suitable for potable water and waste water  
(all materials UKWFBS listed)  
Contact factory for non-standard materials

### Electrodes

Stainless steel 316  
Contact factory for non-standard materials

### Flanges

Carbon steel

### Pressure limitations

≤600mm as flange rating  
≥700mm 6, 10 or 16 bar

### Environmental protection

IP68 (NEMA6P)  
Buriable to 5m (16 ft) depth

### Pressure equipment directive 97/23/EC

This product is applicable in networks for the supply, distribution and discharge of water and associated equipment and is therefore exempt.

### Conductivity

≥5μS/cm

### End connections

PN6 ANSI B16.5 Class 150  
PN10 ANSI/AWWA C207 Class B and D  
PN16 AS2129 Table C or BS10/AS2129 Table D and E

## Electronic Display Unit

### Mounting

Integral with sensor  
OR  
Remote up to 100m (325 ft)  
Longer lengths available on request

### Housing

IP65 (NEMA4)  
Glass-loaded polypropylene, polycarbonate window ULVO rated

### Electrical connections

20mm glands, or accepts  
1/2 in. NPT connections

### Sensor cable

ABB cable supplied as standard  
Armored version available on request

## Power supply\*

Voltage Type	Voltage Range (V) Absolute rating	Frequency (Hz)	VA
AC	85 to 265	47 to 440	<20
DC	11 to 40	–	<20

\*Power supply fully isolated

## Liquid Sensing

Drives output to zero with an empty pipe

## Languages

Operation in English, French, German, Spanish, Italian, Dutch plus others on application

## Temperature Ranges

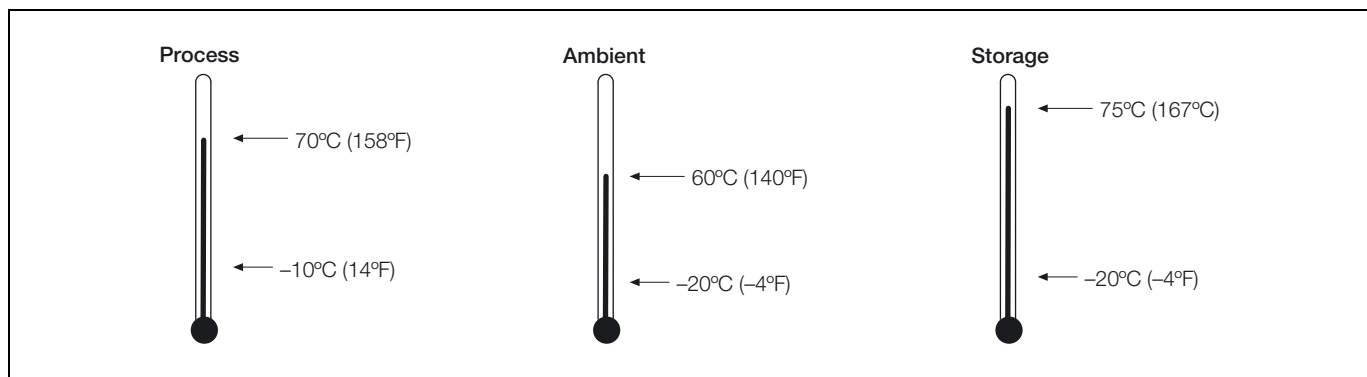

### Output/Inputs

Common

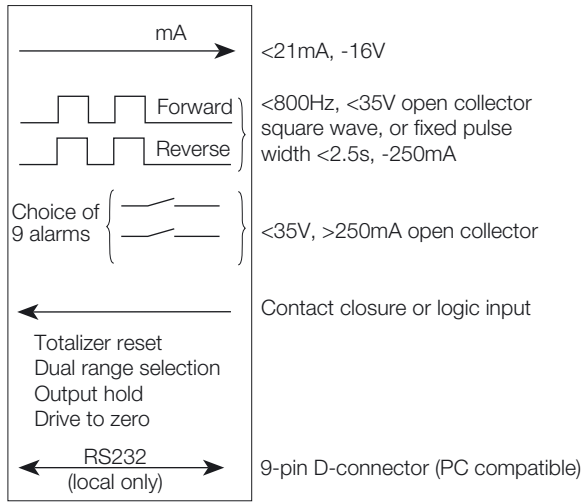

Optional (For blind & 2-line display units)

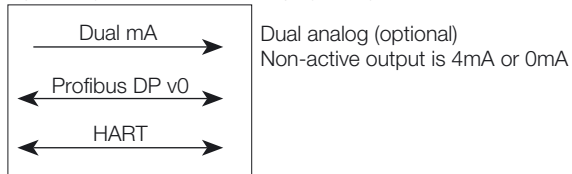

Optional (For keypad units)

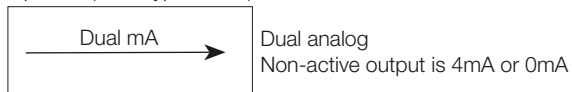

Galvanic isolation to 50V DC between analog pulse/alarm and earth/ground

### Mounting

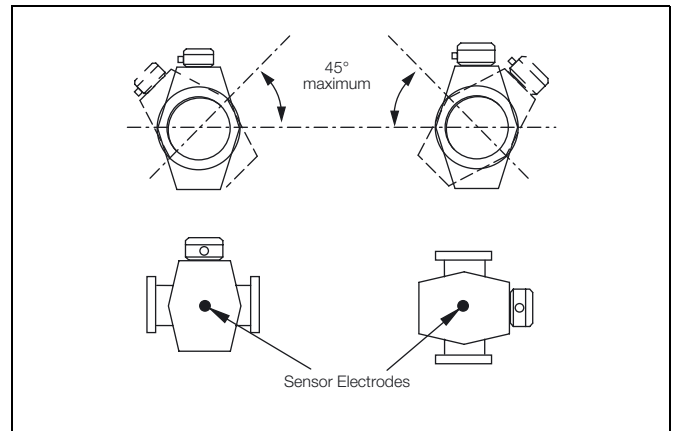

### Pipe Connections

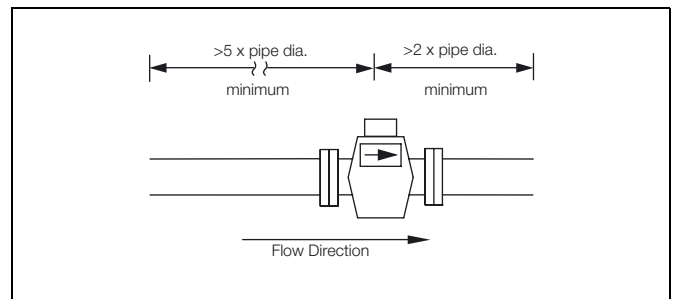

**Sensor Specification (nominal dimensions)**

15 to 2200mm (0.5 to 84 in.)

Meter Size mm	Flange Size			Length A mm (in.)	Approximate Weight kg (lb)
	Metric Flanges (DN)	BS10 Flanges (in.)	AWWA C207 Flanges (NPS)		
15	15	1/2	1/2	200 (7.9)*	7 (15)
20	20	3/4	3/4		
25	25	1	1		
40	40	1 1/2	1 1/2		
50	50	2	2		
65	65	2 1/2	2 1/2		
80	80	3	3	250 (9.8)*	9 (20)
100	100	4	4		10 (23)
150	150	6	6	300 (11.8)*	18 (40)
200	200	8	8	350 (13.8)**	18 (40)
250	250	10	10	450 (17.7)**	24 (54)
300	300	12	12	500 (19.7)**	24 (54)
350	350	14	14	550 (21.7)**	38 (84)
400	400	16	16	600 (23.6)**	55 (121)
450	450	18	18	698 (27.5)**	88 (194)
500	500	20	20	768 (30.2)**	128 (282)
600	600	24	24	918 (36.1)**	100 (220)
700	700	27	28	700 (27.6)***	115 (253)
760	760	30	30	762 (30)***	160 (352)
800	800	–	–	800 (31.5)***	217 (455)
900	900	36	36	900 (35.4)***	315 (693)
1000	1000	39	39	1000 (39.4)***	430 (945)
1050	1050	42	42	1067 (42)***	
1200	1200	48	48	1200 (47.2)***	540 (1190)
1400	1400	54	54	1400 (55.1)***	720 (1585)
1500	1500	60	60	1524 (59)***	880 (1930)
1600	1600	66	66	1600 (63)***	1000 (2160)
1800	1800	72	72	2250 (88.6)***	1450 (3190)
2000	2000	78	78	2500 (98.4)***	1370 (3000)
2200	2200	84	84	2750 (110)***	2000 (4400)

\*Typical tolerance +0/-3mm  
 \*\*Typical tolerance +0/-5mm  
 \*\*\*Typical tolerance +0/-10mm

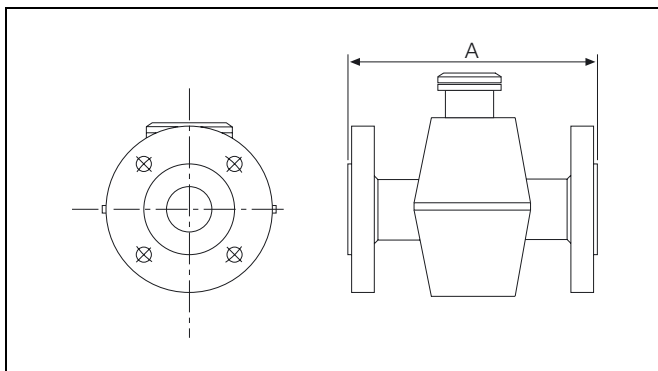



### Overall Dimensions

#### Terminal Box – Sensor Mounted

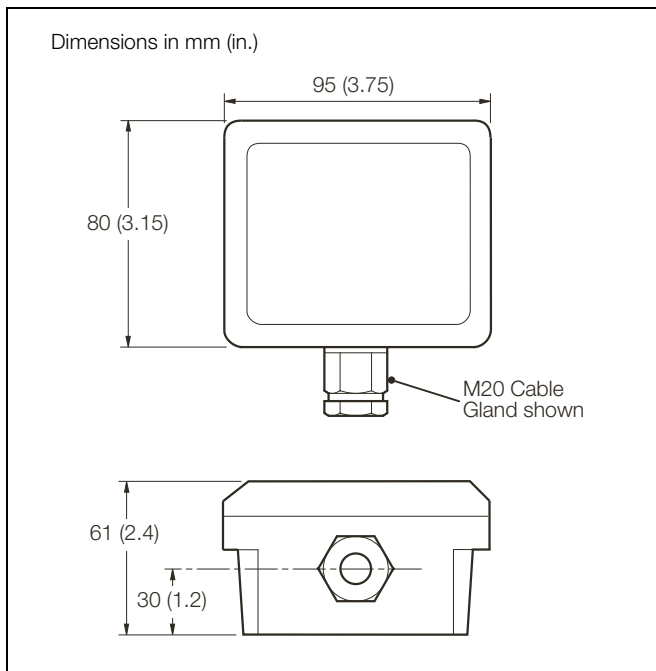

#### IP65/NEMA4 Remote Electronic Display Unit

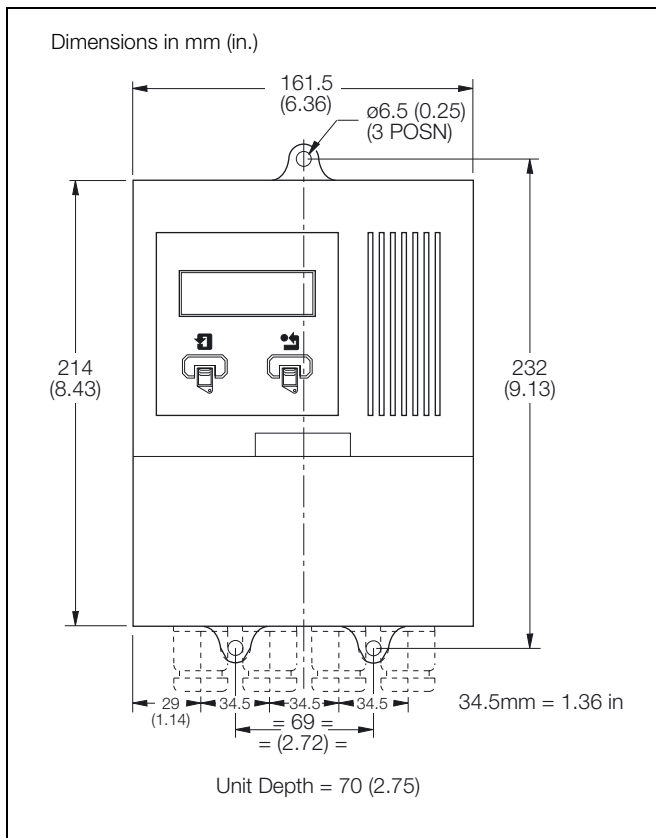

Integral Electronic Display Unit (mounted on Sensor)

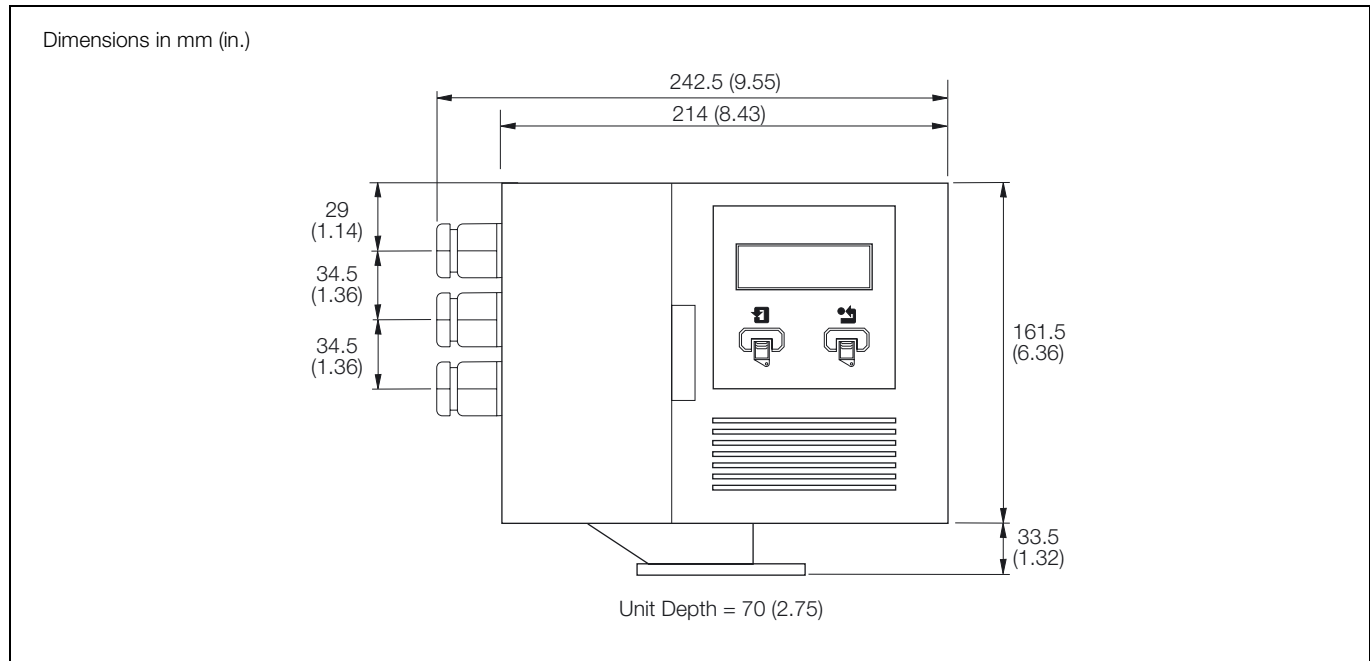

Electrical Connections

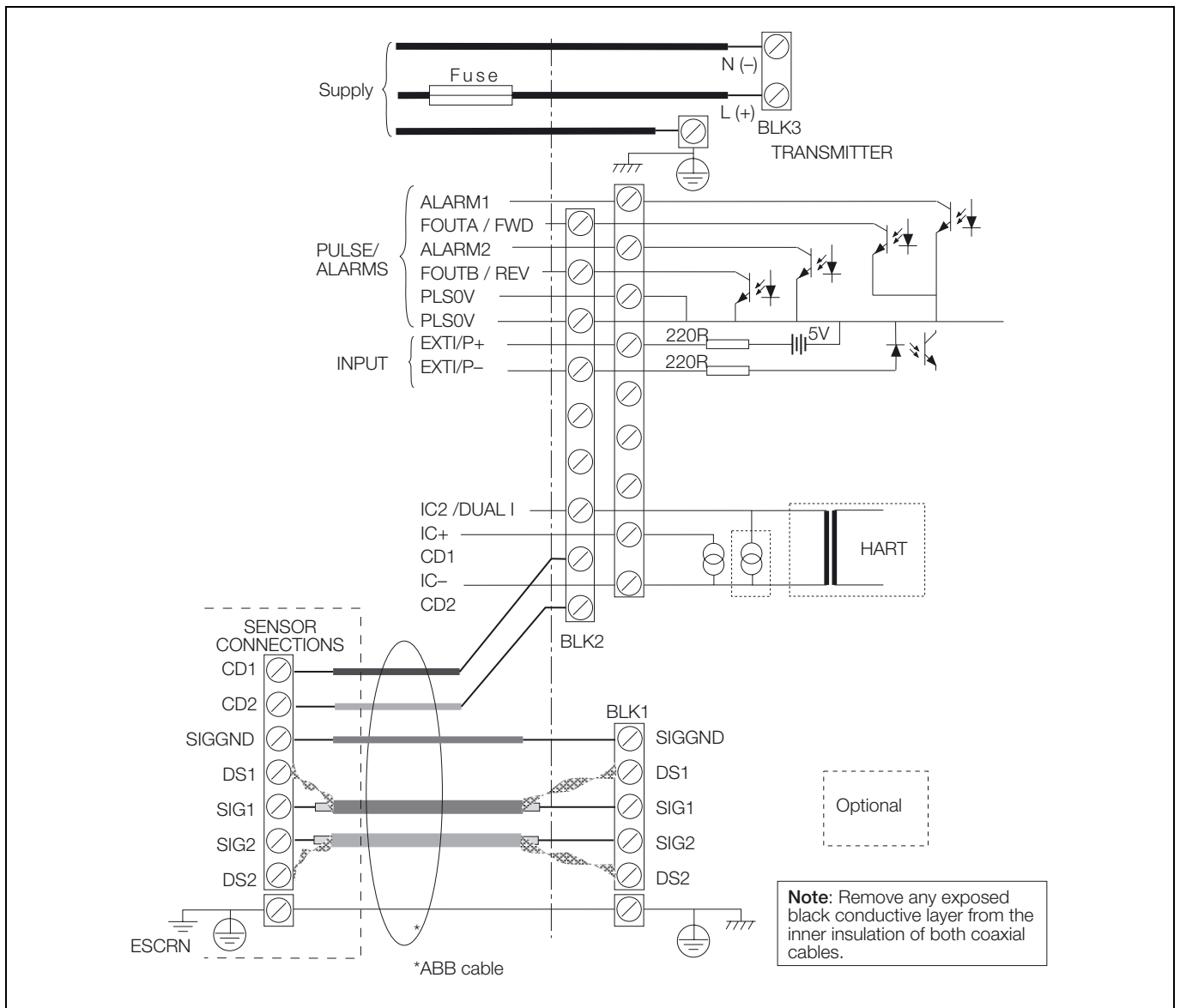

## Ordering Information

Sensor Ordering Code	MF	XXXX	X	X	X	X	0	X	XX	X	XX
<b>Calibrated Bore</b>											
No sensor (Transmitter only)		E000									
15mm (1/2 in.)		E150									
20mm (3/4 in.)		E200									
25mm (1 in.)		E250									
40mm (1 1/2 in.)		E400									
50mm (2 in.)		E500									
65mm (2 1/2 in.)		E650									
80mm (3 in.)		F800									
100mm (4 in.)		F101									
150mm (6 in.)		F151									
200mm (8 in.)		F201									
250mm (10 in.)		F251									
300mm (12 in.)		F301									
350mm (14 in.)		F351									
400mm (16 in.)		F401									
450mm (18 in.)		F451									
500mm (20 in.)		F501									
600mm (24 in.)		F601									
700mm (28 in.)		F701									
760mm (30 in.)		F761									
800mm (31 in.)		F801									
900mm (35 in.)		F901									
1000mm (39 in.)		F102									
1050mm (41 in.)		F112									
1200mm (47 in.)		F122									
1400mm (55 in.)		F142									
1500mm (59 in.)		F152									
1600mm (63 in.)		F162									
1800mm (71 in.)		E182									
2000mm (79 in.)		E202									
2200mm (87 in.)		E222									
≥2400mm (94 in.) – apply to Sales Office											
<b>End Connections – Flanged</b>											
None (Transmitter only)			0								
PN16, fully rated			1								
PN16, 10 bar rated 700mm to 2200mm			C								
PN16, 6 bar rated 700mm to 2200mm			B								
PN10, fully rated			5								
PN6, fully rated 700mm to 2200mm			8								
ANSI B 16.5 class 150, fully rated ≤24 in.			3								
ANSI/AWWA C207 class B fully rated 27 in. to 66 in.			U								
ANSI/AWWA C207 class D fully rated 27 in. to 66 in.			V								
AS2129 Table C fully rated ≤24 in.			F								
AS2129 Table D fully rated ≤66 in.			L								
BS10/AS2129 Table E, fully rated ≤48 in.			7								
BS10 Table D fully rated ≤66 in.			K								
AS4087 Class 16			Z								

**Electromagnetic Flowmeter**

MagMaster – Water & Waste Water Version

SS/MAG/WW Issue 16

Sensor Ordering Code	MF	XXXX	X	X	X	X	0	X	XX	X	XX
<b>Lining Material</b>											
None (Transmitter only)				0							
Elastomer suitable for potable water and waste water – WRAS (UK) Listed				4							
Elastomer suitable for potable water and waste water – ACS (France) Approved				F							
Others on application											
<b>Electrodes</b>											
None (Transmitter only)							0				
316 Stainless Steel (suitable for water and waste water)							1				
Others on application											
<b>Sensor Build Standard</b>											
Transmitter only							0				
General							1				
FM/CSA – GENERAL							8				
<b>Calibration</b>											
Transmitter only									0		
Standard 3-point, with pressure test									1		
8-point, with pressure test									2		
UKAS, with pressure test									5		
Standard 3-point, no pressure test									A		
8-point, no pressure test									B		
UKAS, no pressure test									D		
Standard 3-point; CalMaster Fingerprint & disk; No pressure test									I		
Standard 3-point; CalMaster Fingerprint & disk; With pressure test									J		
<b>Cable Length – User-specified length in 10m increments (90m max.) (Must be '00' for glanding digit 4)</b>										XX	
<b>Glanding</b>											
None (Transmitter only)											0
20mm plastic gland (sensor cable fitted and potted)											1
Conduit entry: 1/2 in. NPT (Blanked) – all North American versions (cable length to be '00')											4
20mm plastic. Cable not fitted.											5
20mm armor. Cable not fitted.											7
<b>Transmitter</b>											
Sensor-mounted MagMaster Transmitter, ≤400mm (16 in.) only											EH
Remote MagMaster Transmitter											ER

<b>Transmitter Ordering Code</b>	X	X	X	X	X	X	X
<b>Power Supply</b>							
None - Sensor only	0						
95V to 240V AC nominal, 47 to 440Hz	1						
11V to 40V DC (Max)	3						
<b>Display</b>							
None (or sensor only)		0					
2-Line Display		3					
3-Line Display with keypad (no HART)		4					
<b>Output Options</b>							
Standard outputs (or sensor only)			0				
Dual current output			1				
HART communications			2				
Profibus DP v0			8				
<b>Transmitter Build Standard</b>							
Transmitter only				0			
General				1			
FM/CSA – GENERAL				3			
<b>Display Orientation</b>							
None (or sensor only)					0		
Standard					1		
Other please enquire							
<b>Language</b>							
None (or sensor only)						0	
English						1	
French						2	
German						3	
Spanish						4	
Italian						5	
Dutch						6	
<b>Labelling</b>							
Factory allocated (internal only)							X



ABB has Sales & Customer Support expertise  
in over 100 countries worldwide

[www.abb.com](http://www.abb.com)

The Company's policy is one of continuous product  
improvement and the right is reserved to modify the  
information contained herein without notice.

Printed in UK (07.07)

© ABB 2007



**ABB Limited**  
Oldends Lane, Stonehouse  
Gloucestershire  
GL10 3TA  
UK  
Tel: +44 (0)1453 826661  
Fax: +44 (0)1453 829671

**ABB Inc.**  
125 E. County Line Road  
Warminster  
PA 18974  
USA  
Tel: +1 215 674 6000  
Fax: +1 215 674 7183