

8012/8013 Series

Electro-pneumatic Valve Positioners

Excellent Dynamic Response and Positioning Accuracy

Accurate, Simple, Rugged

The primary function of a valve positioner is to ensure that the control valve plug position is always proportional to the value of the controller output signal, regardless of packing box friction, diaphragm actuator hysteresis, or out-of-balance forces on the valve plug. The controller output signal may be pneumatic or electric, depending on the type of positioner.

Baker Hughes **Masoneilan™** 8012 and 8013 Series cam positioner is a force-balance electro-pneumatic device which, by directly comparing valve position with a controlled DC output signal, provides excellent dynamic response and positioning accuracy. One multi-lobe cam provides field-changeable linear- or percentage-control characteristics without additional parts.



Operation

The 8013 Series electro-pneumatic cam positioner is able:

- To change the valve action (increase in electrical signal opens or closes the valve)
- To change control characteristics (linear or equal-percentage)
- To operate each of two control valves (split-range)

The 8013 Series positioner is available for either direct action (increase in electrical signal increases output pressure) or reverse action (increase in electrical signal decreases output pressure). In addition, the positioner provides an accurate means of split-ranging controller output signal for sequential operation of two control valves by a single controller.

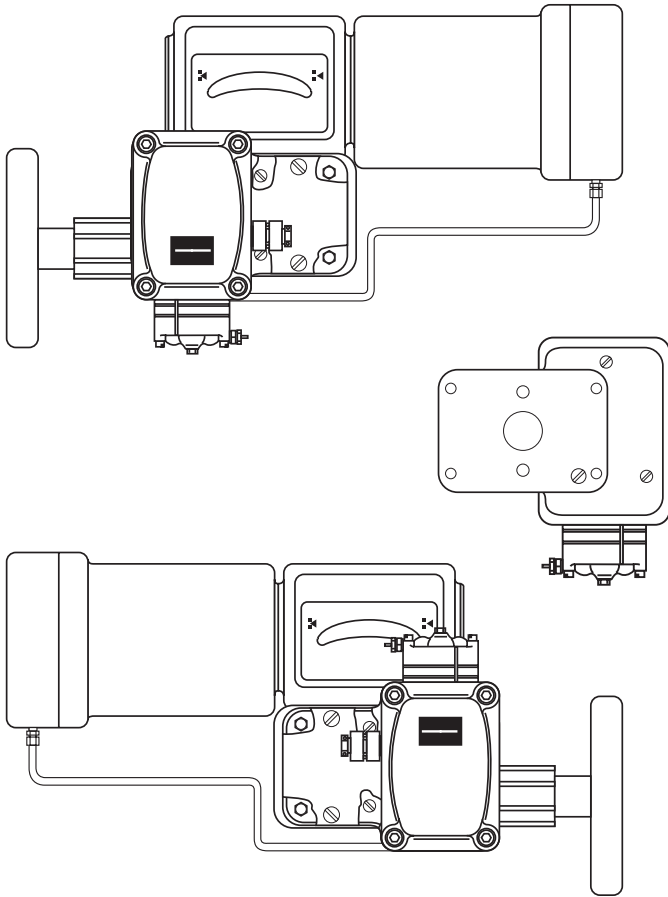

8013 Series cam positioner mounted on Camflex II
(similar on Minitork II and 31000 Series)

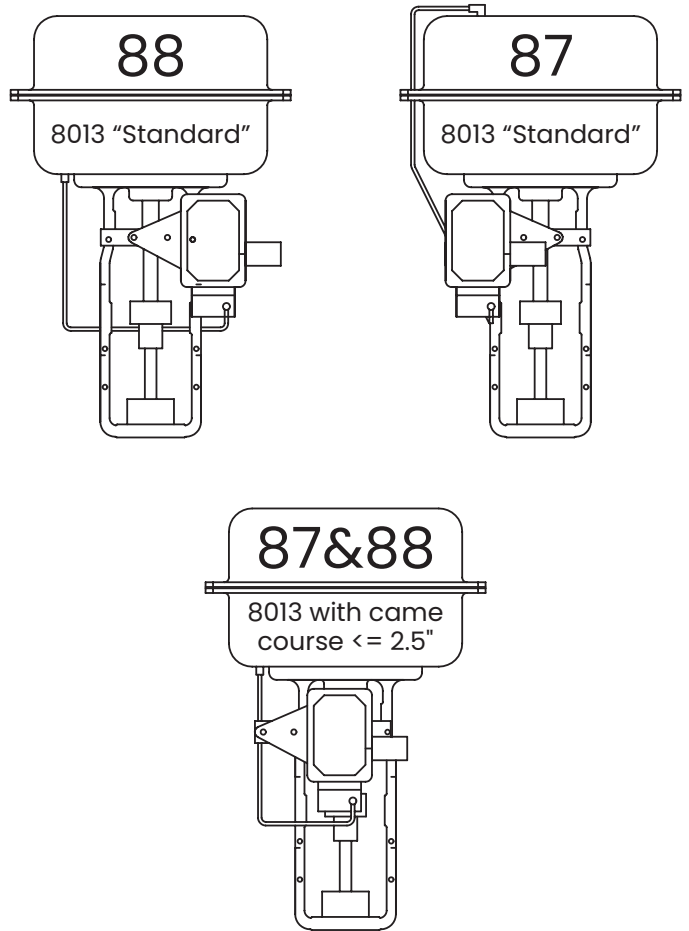

8013 Series positioner mounted on 87/88
multi-spring actuator

Description

Sectional View of Positioner

The installation in hazardous area locations must be in accordance with applicable safety standards.

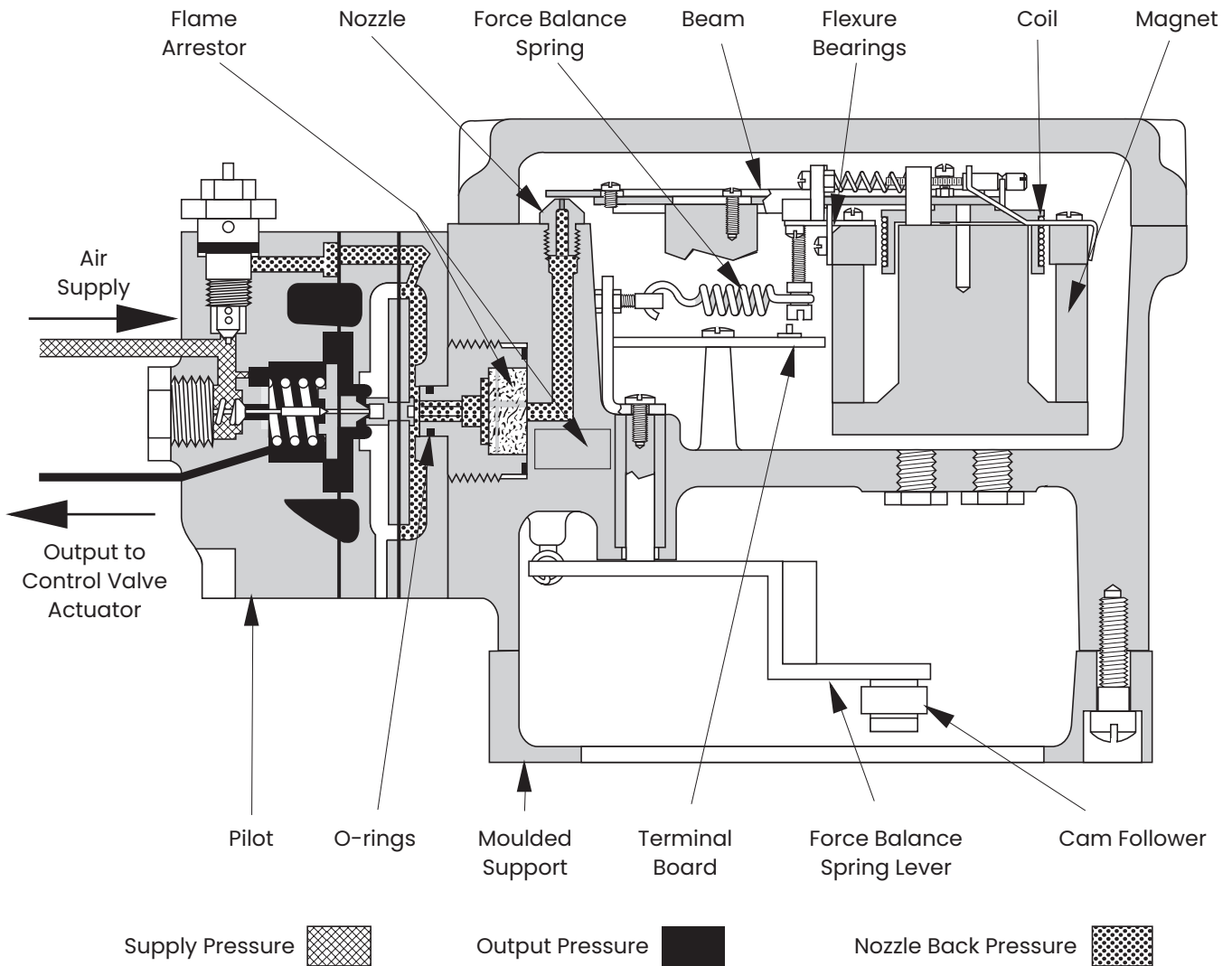

Housing: The cast aluminum case is mounted at the front of the device by means of a mounting plate and a molded support.

Beam and flexure bearings: Beryllium copper flexure bearings provide friction-free fulcrum points for the beam.

Pilot: High-capacity type for fast stroking speeds. The metering tube for the nozzle air supply is equipped with a clean-out plunger.

Cam: Only one cam can be provided, depending on the selected lobe, equal-percentage or linear (and linear split-range) control characteristics. Linkage and associated backlash problems are essentially eliminated by mounting the cam directly to the end of the plug shaft (rotary valves) or the actuator stem (reciprocating valves).

Electrical circuit: The 8013 Series electro-pneumatic positioner can be supplied or easily adapted to accommodate the DC current output signals of nearly all the electric controllers presently available. The coil is impregnated with an insulating material.

Operation

Any variation in the output signal of an electro-pneumatic controller causes the coil to produce a force on the beam, moving the flapper to cover or uncover the nozzle.

The modification in nozzle back pressure causes, through the pilot, a variation of output pressure to the control valve actuator. An increase in electrical signal increases output pressure in direct action and decreases output pressure in reverse action.

The resultant plug motion is transmitted through the positioner lever to the force-balance spring, extending or

compressing the spring until the force exerted by it on the beam balances the opposing force of the coil.

The system is then in equilibrium, and positioner output is stabilized at the necessary level to maintain the desired valve plug position. When the forces on the beam are in equilibrium, there is theoretically no flow of air into or out from the pilot.

Actually, a small bleed is provided between supply and output to increase pilot responsiveness when at equilibrium.

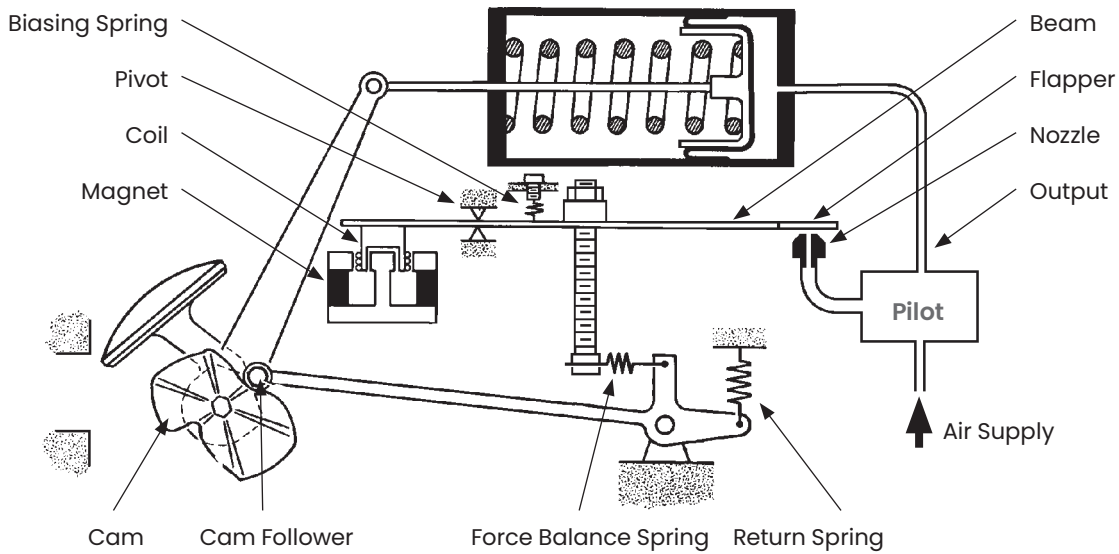

Operation on Camflex II (similar on Minitork II and 31000 Series)

Hazardous Environment Approvals

For all details dealing with Explosion-proof and Intrinsic safety, please refer to 8000 ATEX Manual (ref. 33467).

General Data

Performance Characteristics

Air supply:

1.4 to 5.2 bar (20 to 75 psi) depending on the valve size and actuator action.

Air consumption and output:

Supply	bar	1.4	2.4	5.2
	psi	20	35	75
Maximum consumption (steady state)	st.m3/h	0.40	0.55	0.85
	Scfm	0.24	0.33	0.51
Maximum air output (steady state)	st.m3/h	4.5	8.0	18
	Scfm	2.7	4.8	10.8

Supply pressure influence:

0.3 to 0.7 percent of output pressure for 100 mbar supply pressure change (0.2 to 0.5 percent per psi) depending on supply pressure.

Air connections:

1/4" NPT

Ambient temperature operating range:

- Standard instrument: down to -20°C (-4°F)
- Low temperature instrument: down to -55°C (-67°F)

Note: Also refer to the marking on the device and the 8000 ATEX Manual ref. 33467.

Performance data:

The performance of a complete valve (i.e. the valve and its packing, actuator, positioner, and accessories) depends upon the specific performance of each component. The performance data given below, in average value in percentage of the input span, concerns **Camflex™ II**, **Minitork™ II**, and 87/88 multi-spring actuators equipped with a standard 8013 positioner.

- Hysteresis at mid stroke: 0.8 percent max
- Sensitivity: 0.3 percent max

Electromagnetic compatibility:

Model 8013 fall under the scope of the Article 2.2.(d) of the EMC 2014/30/EU Directive. Consequently, this Directive does not apply.

Weight:

3.5 kg (7.5 lbs)

Electrical Characteristics

Typical circuit resistance is 216 ohm for an input D.C. signal of 4 to 20 mA.

The circuit is available for most current signals such as:

Input d.c. signal	Positioner input resistance	
	ohms	
	8013 model	8012 model
1-5	2753	NA
4-20	216	173
10-50	105	104
Other signals	On request	

Note: for intrinsically safe device, 4-20 mA & 216/173 ohms only.

Zero adjustment:

Vernier screw.

Span adjustment:

Tension adjustment on force balance spring.

Dimensions in mm (inches)

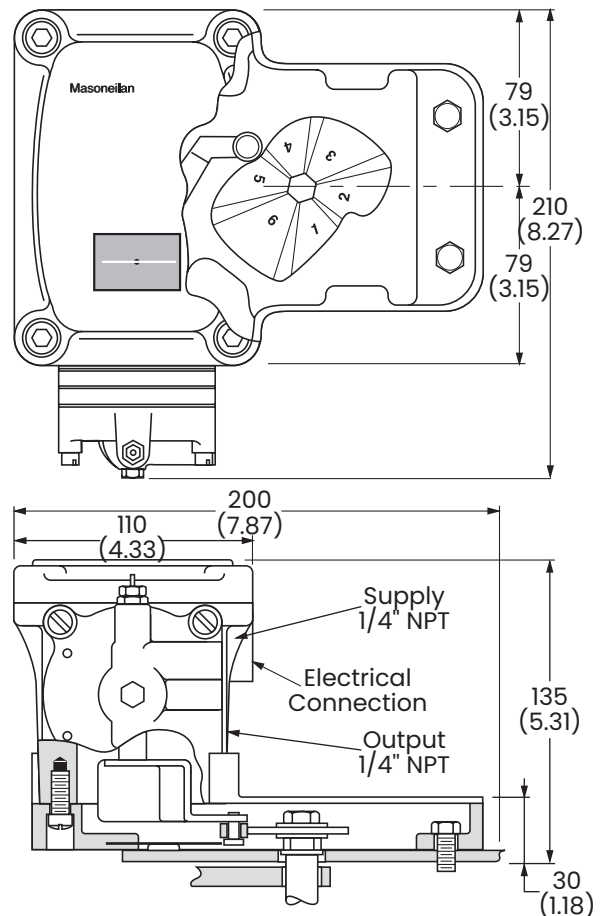

Construction and Part Reference

8012-2-C through 8012-7-C model

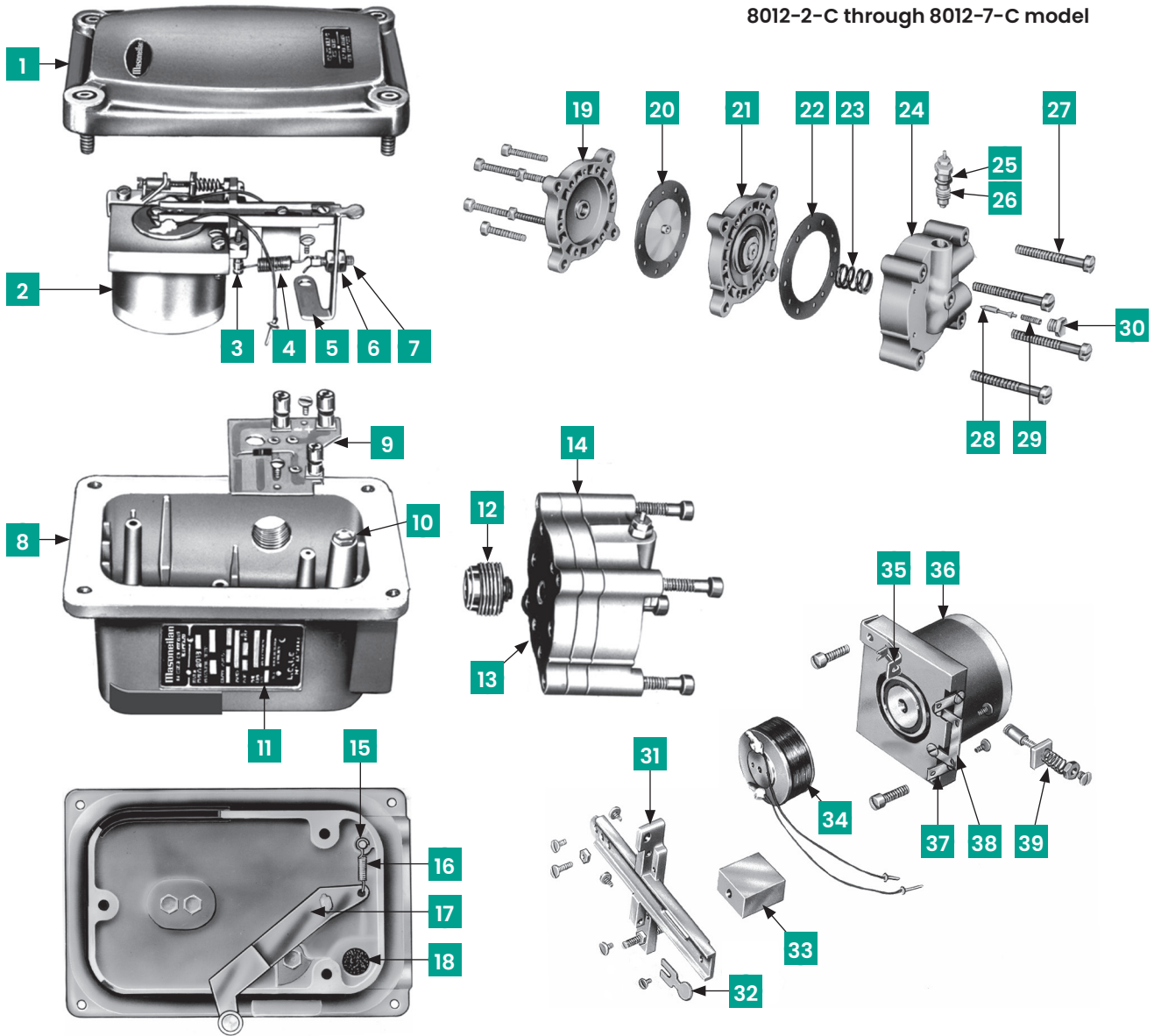

1	Cover
2	Magnet S/A
3	Adjusting screw
4	Spring (force balance)
5	Spring lever
6	Locking nut
7	Adjusting screw
8	Case
9	Terminal board S/A
10	Nozzle
11	Serial plate (metal/plastic)
12	Adapter (flame arrestor)
13	Gasket

14	Relay
15	Groove pin
16	Spring (stroke adj.)
17	Sleeve bearing
18	Flame arrestor
19	Cap
20	Diaphragm S/A
21	Bellofram plate S/A
22	Gasket
23	Spring
24	Relay body
25	O-ring
26	Metering tube S/A

27	Mounting screw (relay)
28	Relay plug
29	Spring
30	Holding screw
31	Beam
32	Flapper
33	Weight
34	Coil S/A
35	Spring bracket
36	Magnet S/A
37	Flexure bearing
38	Flexure bearing
39	Biasing spring

Numbering System

US design with FM approvals

Linear positioner for axial actuators:

Multi-lobe cam positioner for rotary type valves:

Series Identification 8012

Series Identification 8012-b-c

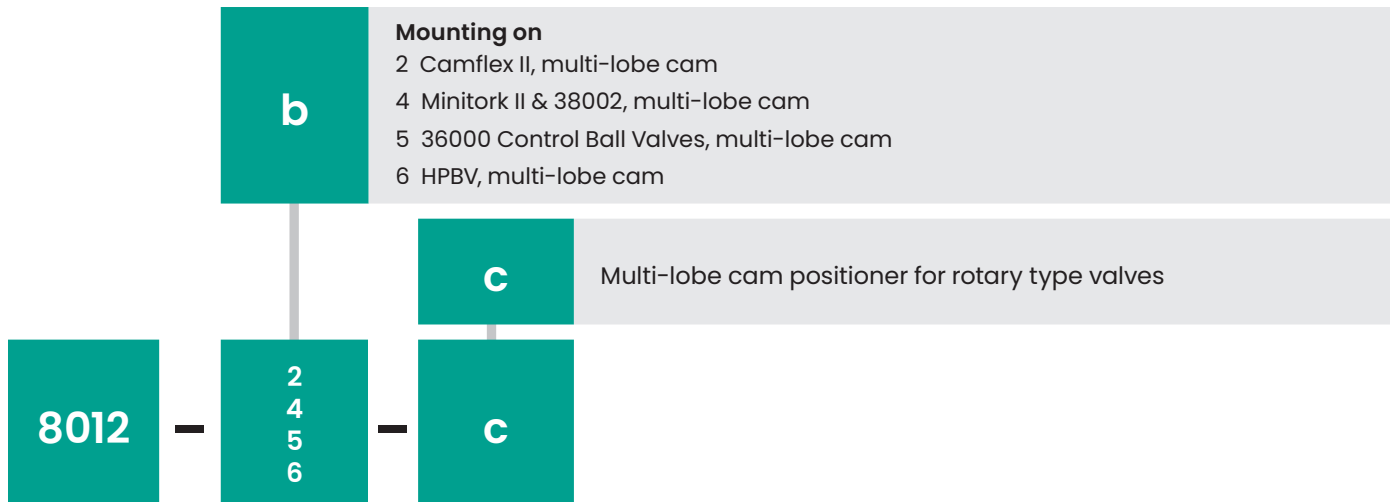

European design with ATEX, CCOE and IA approvals

Series Identification 8013-bd

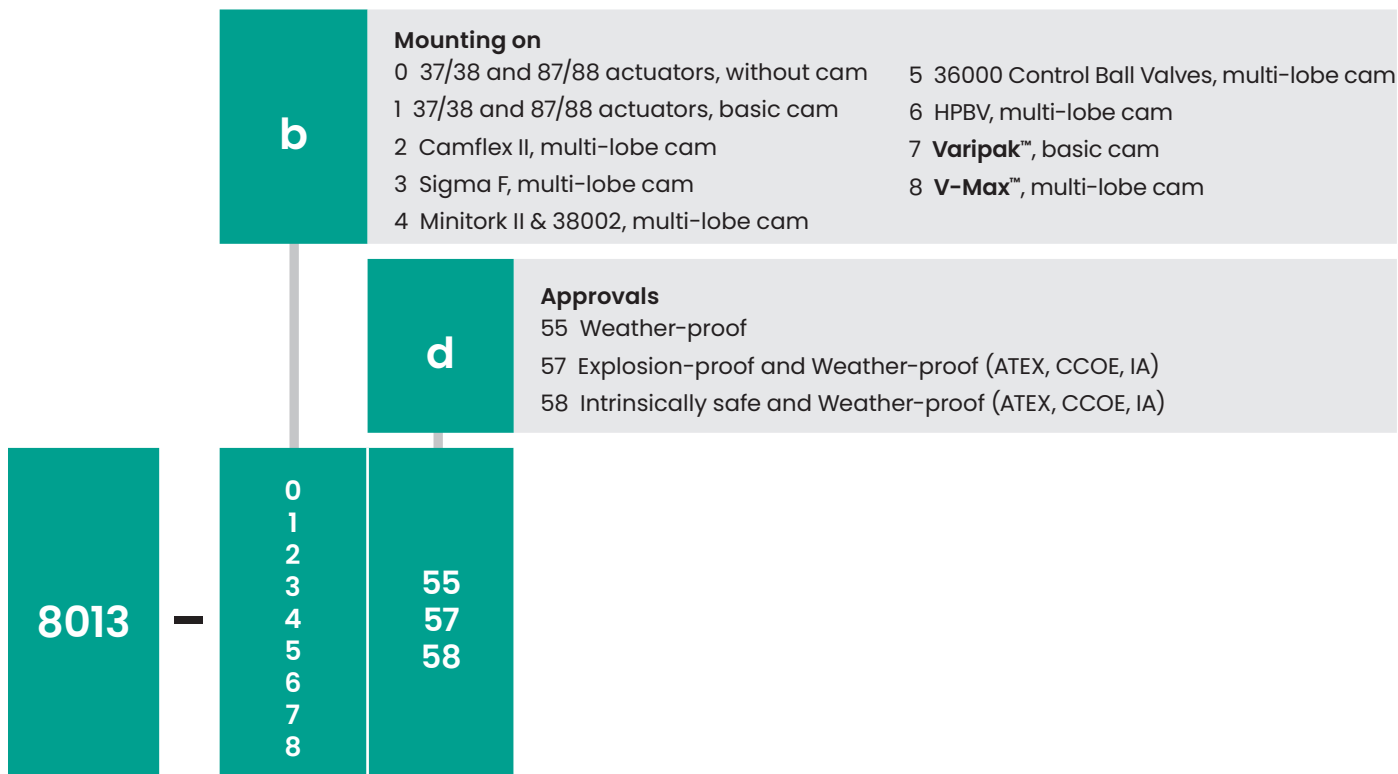

Find the nearest local Channel Partner in your area:

valves.bakerhughes.com/contact-us

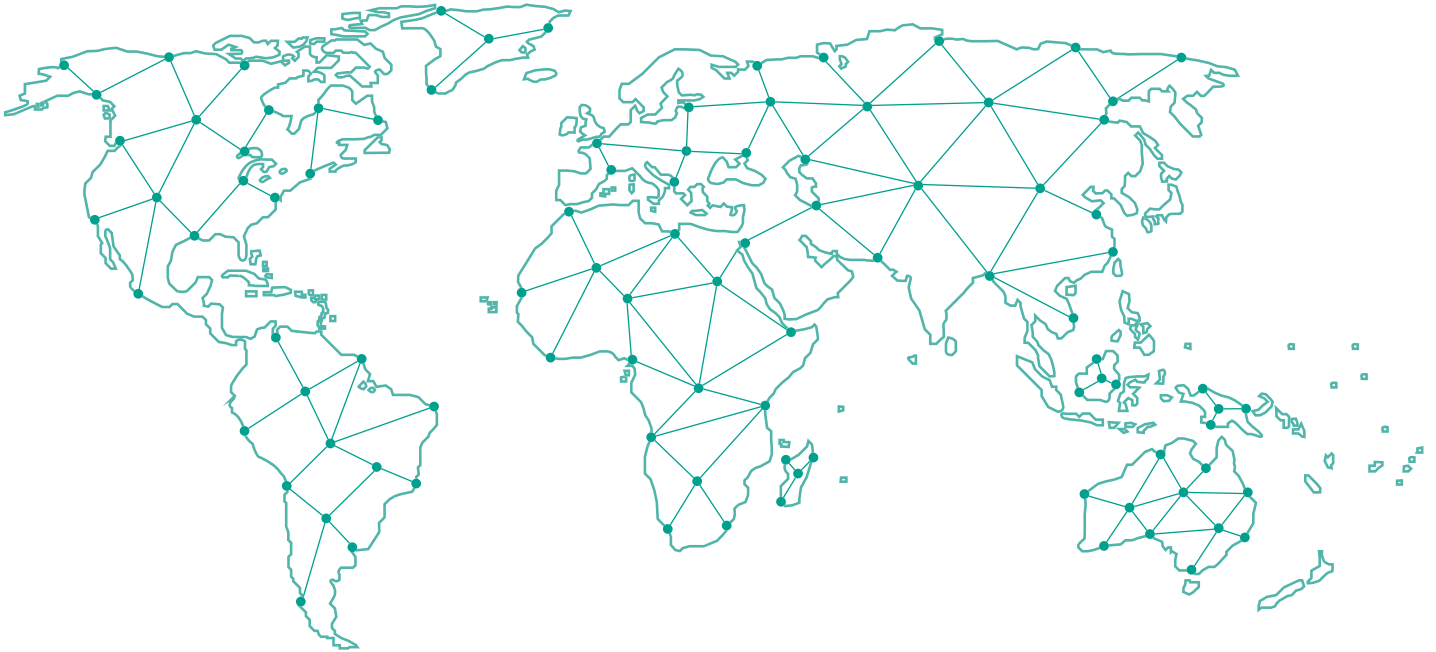

Tech Field Support & Warranty:

Phone: +1-866-827-5378
valvesupport@bakerhughes.com

valves.bakerhughes.com

Baker Hughes 