



Level



Pressure



Flow



Temperature

Liquid
Analysis

Registration

Systems
Components

Services



Solutions

Technical Information

Proline Promass 40E

Coriolis Mass Flow Measuring System

The mass flow measuring system with low cost and basic functionality. The economical alternative to conventional volume flowmeters.



Application

The Coriolis measuring principle operates independently of physical fluid properties, such as viscosity and density.

- Extremely accurate measurement of liquids and gases, e.g. additives, oils, greases, acids, alkalis, lacquers, paints and natural gas
- Fluid temperatures up to +140 °C (+284 °F)
- Process pressures up to 100 bar (1450 psi)
- Mass flow measurement up to 180 t/h (6600 lb/min)

Approvals for hazardous area:

- ATEX, FM, CSA, TIIS, IECEx, NEPSI

Approvals in the food industry/hygiene sector:

- 3A authorization

Connection to process control systems:

- HART

Relevant safety aspects:

- Pressure Equipment Directive (PED)

Your benefits

The Promass measuring devices make it possible to simultaneously record several process variables (mass/volume/corrected volume) for various process conditions during measuring operation.

The **Proline transmitter concept** comprises:

- Modular device and operating concept resulting in a higher degree of efficiency

The **Promass sensors**, tried and tested in over 100000 applications, offer:

- Flow measurement in compact design
- Insensitivity to vibrations thanks to balanced two-tube measuring system
- Immune from external piping forces due to robust design
- Easy installation without taking inlet and outlet runs into consideration

Table of contents

Function and system design	3	Mechanical construction	16
Measuring principle	3	Design, dimensions	16
Measuring system	3	Rupture disk	29
Input	4	Weight	30
Measured variable	4	Materials	30
Measuring range	4	Material load curves	31
Operable flow range	5	Process connections	34
Input signal	5	Human interface	34
Output	5	Display elements	34
Output signal	5	Languages	34
Signal on alarm	5	Remote operation	34
Load	5	Certificates and approvals	34
Low flow cutoff	5	CE mark	34
Galvanic isolation	5	C-Tick symbol	34
Switching output	5	Ex approval	34
Power supply	6	Hygienic compatibility	34
Electrical connection Measuring unit	6	Other standards and guidelines	35
Electrical connection, terminal assignment	6	Pressure Equipment Directive	35
Supply voltage	6	Ordering Information	35
Cable entries	6	Accessories	35
Power consumption	6	Documentation	35
Power supply failure	6	Registered trademarks	35
Potential equalization	6		
Performance characteristics	7		
Reference operating conditions	7		
Maximum measured error	7		
Repeatability	8		
Influence of fluid temperature	8		
Influence of fluid pressure	9		
Design fundamentals	9		
Operating conditions: Installation	9		
Installation instructions	9		
Inlet and outlet runs	12		
System pressure	12		
Operating conditions: Environment	13		
Ambient temperature range	13		
Storage temperature	13		
Degree of protection	13		
Shock resistance	13		
Vibration resistance	13		
Electromagnetic compatibility (EMC)	13		
Operating conditions: Process	14		
Fluid temperature range	14		
Fluid pressure range (nominal pressure)	14		
Rupture disk in the sensor housing (optional)	14		
Limiting flow	14		
Pressure loss	14		

Function and system design

Measuring principle

The measuring principle is based on the controlled generation of Coriolis forces. These forces are always present when both translational and rotational movements are superimposed.

$$F_C = 2 \cdot \Delta m (v \cdot \omega)$$

F_C = Coriolis force

Δm = moving mass

ω = rotational velocity

v = radial velocity in rotating or oscillating system

The amplitude of the Coriolis force depends on the moving mass Δm , its velocity v in the system, and thus on the mass flow. Instead of a constant angular velocity ω , the Promass sensor uses oscillation.

In the sensor, two parallel measuring tubes containing flowing fluid oscillate in antiphase, acting like a tuning fork. The Coriolis forces produced at the measuring tubes cause a phase shift in the tube oscillations (see illustration):

- At zero flow, in other words when the fluid is at a standstill, the two tubes oscillate in phase (1).
- Mass flow causes deceleration of the oscillation at the inlet of the tubes (2) and acceleration at the outlet (3).

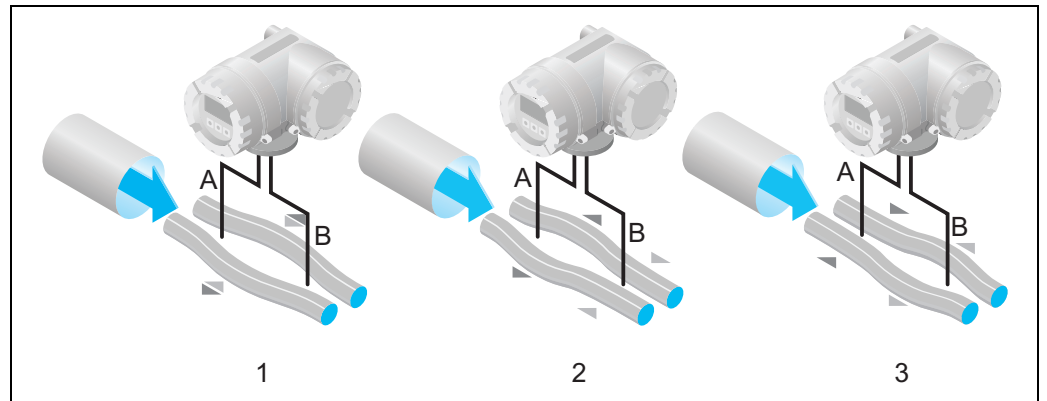

The phase difference (A-B) increases with increasing mass flow. Electrodynamic sensors register the tube oscillations at the inlet and outlet.

System balance is ensured by the antiphase oscillation of the two measuring tubes. The measuring principle operates independently of temperature, pressure, viscosity, conductivity and flow profile.

Volume measurement

The measuring tubes are continuously excited at their resonance frequency. A change in the mass and thus the density of the oscillating system (comprising measuring tubes and fluid) results in a corresponding, automatic adjustment in the oscillation frequency. Resonance frequency is thus a function of fluid density. The density value obtained in this way can be used in conjunction with the measured mass flow to calculate the volume flow.

The temperature of the measuring tubes is also determined in order to calculate the compensation factor due to temperature effects.

Measuring system

The measuring system consists of a transmitter and a sensor (compact version):

- Promass 40 transmitter
- Promass E sensor (DN 8 to 80; 3/8" to 3")

Input

Measured variable

- Mass flow (proportional to the phase difference between two sensors mounted on the measuring tube to register a phase shift in the oscillation)
- Volume flow (calculated from mass flow and fluid density. The density is proportional to the resonance frequency of the measuring tubes).
- Measuring tube temperature (by temperature sensors) for calculatory compensation of temperature effects.

Measuring range

Measuring ranges for liquids

DN		Range for full scale values (liquids) $\dot{m}_{\min(F)}$ to $\dot{m}_{\max(F)}$	
[mm]	[inch]	[kg/h]	[lb/min]
8	3/8"	0 to 2000	0 to 73.5
15	1/2"	0 to 6500	0 to 238
25	1"	0 to 18000	0 to 660
40	1 1/2"	0 to 45000	0 to 1650
50	2"	0 to 70000	0 to 2570
80	3"	0 to 180000	0 to 6600

Measuring ranges for gases

The full scale values depend on the density of the gas. Use the formula below to calculate the full scale values:

$$\dot{m}_{\max(G)} = \dot{m}_{\max(F)} \cdot \rho_{(G)} \div x \text{ [kg/m}^3\text{]}$$

$$\dot{m}_{\max(G)} = \text{max. full scale value for gas [kg/h]}$$

$$\dot{m}_{\max(F)} = \text{max. full scale value for liquid [kg/h]}$$

$$\rho_{(G)} = \text{Gas density in [kg/m}^3\text{] at operating conditions}$$

DN		x
[mm]	[inch]	
8	3/8"	85
15	1/2"	110
25	1"	125
40	1 1/2"	125
50	2"	125
80	3"	155

Here, $\dot{m}_{\max(G)}$ can never be greater than $\dot{m}_{\max(F)}$

Calculation example for gas:

- Sensor type: Promass E, DN 50
- Gas: air with a density of 60.3 kg/m³ (at 20 °C and 50 bar)
- Measuring range (liquid): 70000 kg/h
- x = 125 (for Promass E DN 50)

Max. possible full scale value:

$$\dot{m}_{\max(G)} = \dot{m}_{\max(F)} \cdot \rho_{(G)} \div x \text{ [kg/m}^3\text{]} = 70000 \text{ kg/h} \cdot 60.3 \text{ kg/m}^3 \div 125 \text{ kg/m}^3 = 33800 \text{ kg/h}$$

Recommended full scale values

See information in the "Limiting flow" section → 14

Operable flow range Flow rates above the preset full scale value do not overload the amplifier, i.e. the totalizer values are registered correctly.

Input signal **Status input (auxiliary input):**
 U = 3 to 30 V DC, $R_i = 5 \text{ k}\Omega$, galvanically isolated.
 Configurable for: totalizer reset, positive zero return, error message reset, zero point adjustment start, batching start/stop (optional).

Output

Output signal **Current output:**
 Active/passive selectable, galvanically isolated, time constant selectable (0.05 to 100 s), full scale value selectable, temperature coefficient: typically 0.005% o.f.s./°C, resolution: 0.5 μA

- Active: 0/4 to 20 mA, $R_L < 700 \Omega$ (for HART: $R_L \geq 250 \Omega$)
- Passive: 4 to 20 mA; supply voltage U_s 18 to 30 V DC; $R_i \geq 150 \Omega$

Pulse/frequency output:
 Passive, open collector, 30 V DC, 250 mA, galvanically isolated.

- Frequency output: full scale frequency 2 to 1000 Hz ($f_{\text{max}} = 1250 \text{ Hz}$), on/off ratio 1:1, pulse width max. 10 s
- Pulse output: pulse value and pulse polarity selectable, pulse width configurable (0.5 to 2000 ms)

Signal on alarm **Current output**
 Failsafe mode selectable (e.g. in accordance with NAMUR Recommendation NE 43)

Pulse/frequency output
 Failsafe mode selectable

Status output
 Nonconductive in the event of a fault or if the power supply fails

Load see "Output signal"

Low flow cutoff Switch points for low flow are selectable.

Galvanic isolation All circuits for inputs, outputs, and power supply are galvanically isolated from each other.

Switching output **Status output (Promass 80)**

- Open collector
- max. 30 V DC / 250 mA
- galvanically isolated
- Configurable for: error messages, Empty Pipe Detection (EPD), flow direction, limit values

Power supply

Electrical connection Measuring unit

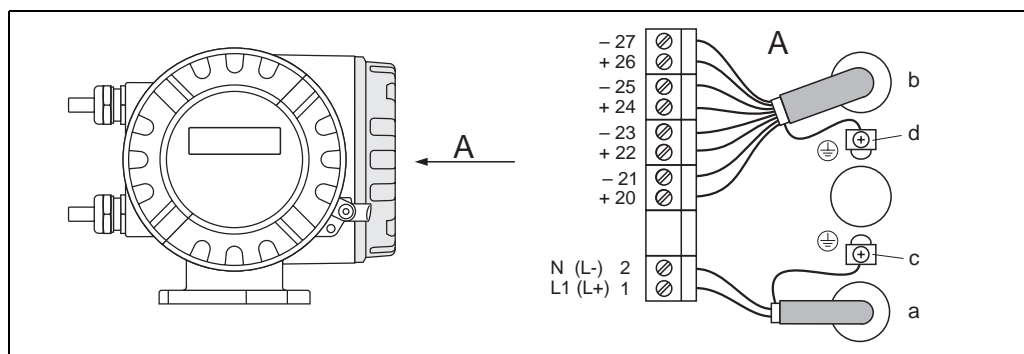

Connecting the transmitter, cable cross-section: max. 2.5 mm²

- a Cable for power supply: 85 to 260 V AC, 20 to 55 V AC, 16 to 62 V DC
Terminal No. 1: L1 for AC, L+ for DC
Terminal No. 2: N for AC, L- for DC
- b Signal cable: see Terminal assignment → 6
- c Ground terminal for protective conductor
- d Ground terminal for signal cable shield

Electrical connection, terminal assignment

Order version	Terminal No. (inputs/outputs)			
	20 (+) / 21 (-)	22 (+) / 23 (-)	24 (+) / 25 (-)	26 (+) / 27 (-)
40***_*****A	-	-	Frequency output	Current output, HART
40***_*****D	Status input	Status output	Frequency output	Current output, HART
40***_*****S	-	-	Frequency output Ex i, passive	Current output Ex i active, HART
40***_*****T	-	-	Frequency output Ex i, passive	Current output Ex i passive, HART

Supply voltage

85 to 260 V AC, 45 to 65 Hz
20 to 55 V AC, 45 to 65 Hz
16 to 62 V DC

Cable entries

Power-supply and signal cables (inputs/outputs):

- Cable entry M20 × 1.5 (8 to 12 mm / 0.31" to 0.47")
- Thread for cable entries, 1/2" NPT, G 1/2"

Power consumption

AC: <15 VA (including sensor)
DC: <15 W (including sensor)

Switch-on current:

- Max. 13.5 A (< 50 ms) at 24 V DC
- Max. 3 A (< 5 ms) at 260 V AC

Power supply failure

Lasting min. 1 power cycle:

- EEPROM saves measuring system data if the power supply fails
- HistoROM/S-DAT: exchangeable data storage chip with sensor specific data (nominal diameter, serial number, calibration factor, zero point, etc.)

Potential equalization

No special measures for potential equalization are required. For instruments for use in hazardous areas, observe the corresponding guidelines in the specific Ex documentation.

Performance characteristics

Reference operating conditions

- Error limits following ISO/DIS 11631
- Water, typically 20 to 30 °C (68 to 86 °F); 2 to 4 bar (30 to 60 psi)
- Data according to calibration protocol ± 5 °C (± 9 °F) and ± 2 bar (± 30 psi)
- Accuracy based on accredited calibration rigs according to ISO 17025

Maximum measured error

The following values refer to the pulse/frequency output. Measured error at the current output is typically ± 5 μ A. Design fundamentals → 9.

o.r. = of reading

Mass flow and volume flow (liquids)

$\pm 0.50\%$ o.r.

Mass flow (gases)

$\pm 1.00\%$ o.r.

Density (liquid)

- ± 0.0005 g/cc (under reference conditions)
- ± 0.0005 g/cc (after field density calibration under process conditions)
- ± 0.02 g/cc (over the entire measuring range of the sensor)

1 g/cc = 1 kg/l

Temperature

± 0.5 °C $\pm 0.005 \cdot T$ °C
 $(\pm 1$ °F $\pm 0.003 \cdot (T - 32)$ °F)

T = medium temperature

Zero point stability

DN		Zero point stability	
[mm]	[inch]	[kg/h] or [l/h]	[lb/min]
8	3/8"	0.20	0.0074
15	1/2"	0.65	0.0239
25	1"	1.80	0.0662
40	1 1/2"	4.50	0.1654
50	2"	7.00	0.2573
80	3"	18.00	0.6615

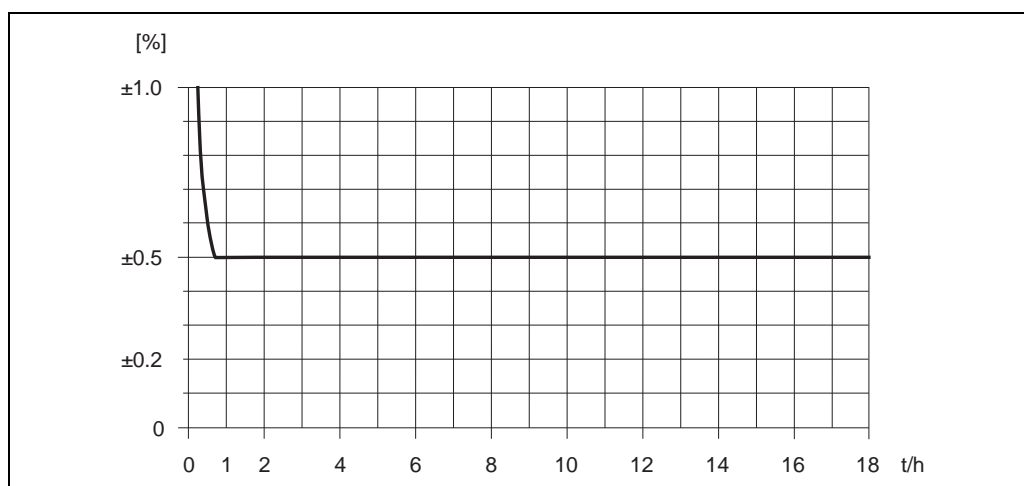
Example for max. measured error

A0012900

Max. measured error in % of measured value (example: Promass 40E / DN 25)

Flow values (example)

Design fundamentals → 9

Turn down	Flow		Max. measured error [% o.r.]
	[kg/h] or [l/h]	[lb/min]	
250 : 1	72	2.646	2.5
100 : 1	180	6.615	1.0
50 : 1	360	13.23	0.5
10 : 1	1800	66.15	0.5
2 : 1	9000	330.75	0.5

o.r. = of reading

Repeatability

Design fundamentals → 9.

o.r. = of reading

Mass flow and volume flow (liquids)

±0.25% o.r.

Mass flow (gases)

±0.50% o.r.

Density (liquids)

±0.00025 g/cc

1 g/cc = 1 kg/l

Temperature

±0.25 °C ± 0.0025 · T °C
(±1 °F ± 0.003 · (T-32) °F)

T = Medium temperature

Influence of fluid temperature

When there is a difference between the temperature for zero point adjustment and the process temperature, the typical measured error of the Promass sensor is ±0.0003% of the full scale value / °C (±0.0001% of the full scale value / °F).

Influence of fluid pressure

The table below shows the effect on accuracy of mass flow due to a difference between calibration pressure and process pressure.

DN		Promass E [% o.r./bar]
[mm]	[inch]	
8	3/8"	no influence
15	1/2"	no influence
25	1"	no influence
40	1 1/2"	no influence
50	2"	-0.009
80	3"	-0.020

o.r. = of reading

Design fundamentals

Dependent on the flow:

- Flow \geq Zero point stability \div (base accuracy \div 100)
 - Max. measured error: \pm base accuracy in % o.r.
 - Repeatability: \pm 1/2 · base accuracy in % o.r.
- Flow $<$ Zero point stability \div (base accuracy \div 100)
 - Max. measured error: \pm (zero point stability \div measured value) · 100% o.r.
 - Repeatability: \pm 1/2 · (zero point stability \div measured value) · 100% o.r.

o.r. = of reading

Base accuracy for	Promass 40E
Mass flow liquids	0.50
Volume flow liquids	0.50
Mass flow gases	1.00

Operating conditions: Installation

Installation instructions

Note the following points:

- No special measures such as supports are necessary. External forces are absorbed by the construction of the instrument, for example the secondary containment.
- The high oscillation frequency of the measuring tubes ensures that the correct operation of the measuring system is not influenced by pipe vibrations.
- No special precautions need to be taken for fittings which create turbulence (valves, elbows, T-pieces etc.), as long as no cavitation occurs.

Mounting location

Entrained air or gas bubbles in the measuring tube can result in an increase in measuring errors.

Therefore, avoid the following mounting locations in the pipe installation:

- Highest point of a pipeline. Risk of air accumulating.
- Directly upstream of a free pipe outlet in a vertical pipeline.

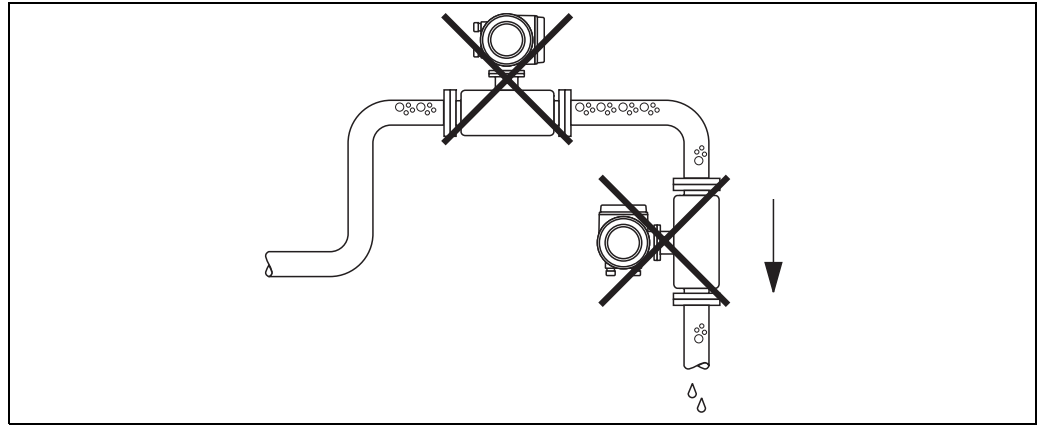

Mounting location

Notwithstanding the above, the installation proposal below permits installation in an open vertical pipeline. Pipe restrictions or the use of an orifice with a smaller cross-section than the nominal diameter prevent the sensor running empty while measurement is in progress.

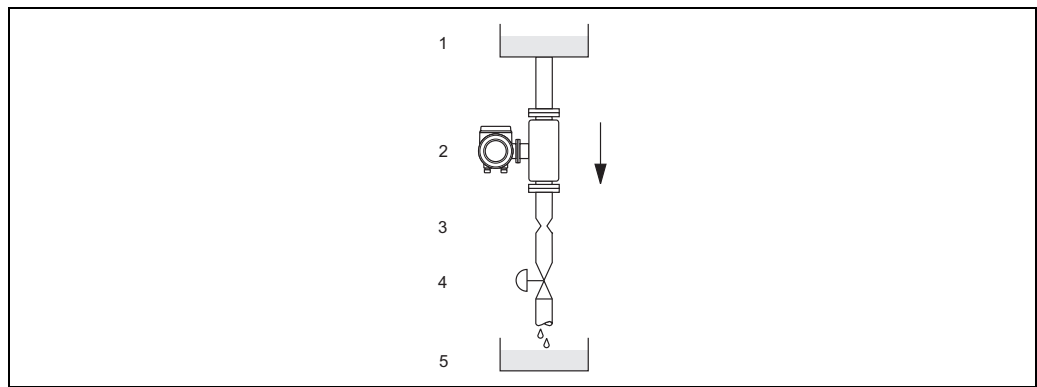

Installation in a down pipe (e.g. for batching applications)

- 1 Supply tank
- 2 Sensor
- 3 Orifice plate, pipe restriction (see Table following page)
- 4 Valve
- 5 Batching tank

DN		Ø Orifice plate, pipe restriction	
[mm]	[inch]	[mm]	[inch]
8	3/8"	6	0.24
15	1/2"	10	0.40
25	1"	14	0.55
40	1 1/2"	22	0.87
50	2"	28	1.10
80	3"	50	2.00

Orientation



Make sure that the direction of the arrow on the nameplate of the sensor matches the direction of flow (direction of fluid flow through the pipe).

Vertical (view V)

Recommended orientation with upward direction of flow. When fluid is not flowing, entrained solids will sink down and gases will rise away from the measuring tube. Thus the measuring tubes can be completely drained and protected against solids buildup.

Horizontal (views H1 / H2)

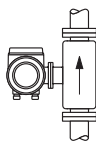
The measuring tubes must be horizontal and beside each other. When installation is correct the transmitter housing is above or below the pipe (views H1/H2). Always avoid having the transmitter housing in the same horizontal plane as the pipe. Please note the special installation instructions → 11.

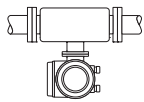
Orientation	Vertical	Horizontal, Transmitter head up	Horizontal, Transmitter head down
	 View V a0004572	 View H1 a0004576	 View H2 a0004580
Standard, Compact version	✓✓	✓✓	✓✓ ①

- ✓✓ = Recommended orientation
- ✓ = Orientation recommended in certain situations
- ✗ = Impermissible orientation

To ensure that the maximum permitted ambient temperature for the transmitter is not exceeded we recommend the following orientation:

① = For fluids with low temperatures, we recommend the horizontal orientation with the transmitter head pointing upwards (view H1) or the vertical orientation (view V).

Special installation instructions



Caution!

When using a bent measuring tube and horizontal installation, the position of the sensor has to be matched to the fluid properties!

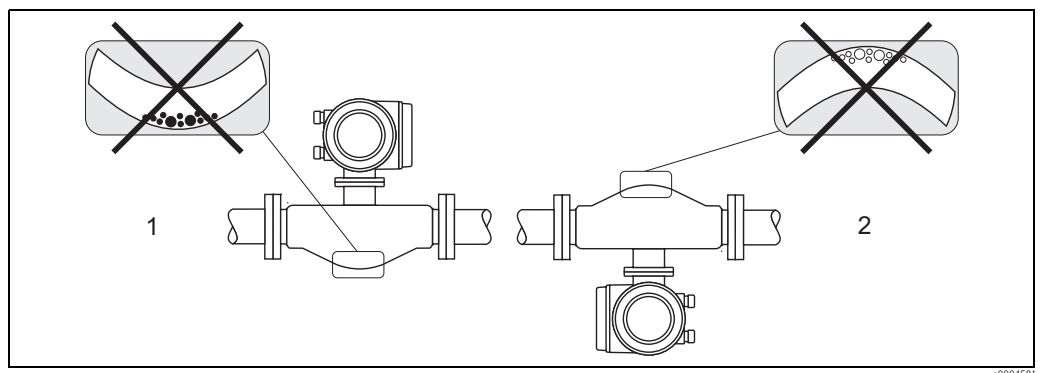

Horizontal installation for sensors with a bent measuring tube

- 1 Not suitable for fluids with entrained solids. Risk of solids accumulating.
- 2 Not suitable for outgassing fluids. Risk of air accumulating.

Heating

Some fluids require suitable measures to avoid heat transfer at the sensor. Heating can be electric, e.g. with heated elements, or by means of hot water or steam pipes made of copper or heating jackets.



Caution!

- If using an electric trace heating system whose heating is regulated via phase angle control or pulse packages, influence on the measured values cannot be ruled out due to magnetic fields (i.e. for values that are greater than the values approved by the EN standard (sine 30 A/m)). In such cases, the sensor must be magnetically shielded.

The secondary containment can be shielded with tin plates or electric sheets without preferential direction (e.g. V330-35A) with the following properties:

- Relative magnetic permeability $\mu_r \geq 300$
- Plate thickness $d \geq 0.35 \text{ mm}$ ($d \geq 0.014''$)

- Information on permitted temperature ranges → 14

Special heating jackets, which can be ordered separately from Endress+Hauser as an accessory, are available for the sensors.

Thermal insulation

Some fluids require suitable measures to avoid loss of heat at the sensor. A wide range of materials can be used to provide the required thermal insulation.

Zero point adjustment

All measuring devices are calibrated with state-of-the-art technology. The zero point determined in this way is imprinted on the nameplate of the device. Calibration takes place under reference operating conditions → 7. Consequently, the zero point adjustment is generally **not** necessary for Promass!

Experience shows that the zero point adjustment is advisable only in special cases:

- To achieve highest measuring accuracy also with very small flow rates.
- Under extreme process or operating conditions (e.g. very high process temperatures or very high viscosity fluids).

Inlet and outlet runs

There are no installation requirements regarding inlet and outlet runs.

System pressure

It is important to ensure that cavitation does not occur, because it would influence the oscillation of the measuring tube. No special measures need to be taken for fluids which have properties similar to water under normal conditions.

In the case of liquids with a low boiling point (hydrocarbons, solvents, liquefied gases) or in suction lines, it is important to ensure that pressure does not drop below the vapor pressure and that the liquid does not start to boil. It is also important to ensure that the gases that occur naturally in many liquids do not outgas. Such effects can be prevented when system pressure is sufficiently high.

Therefore, the following locations should be preferred for installation:

- Downstream from pumps (no danger of vacuum)
- At the lowest point in a vertical pipe

Operating conditions: Environment

Ambient temperature range

Sensor, transmitter:

- Standard: -20 to $+60$ °C (-4 to $+140$ °F)
- Optional: -40 to $+60$ °C (-40 to $+140$ °F)



Note!

- Install the device at a shady location. Avoid direct sunlight, particularly in warm climatic regions.
 - At ambient temperatures below -20 °C (-4 °F) the readability of the display may be impaired.
-

Storage temperature -40 to $+80$ °C (-40 to $+175$ °F), preferably $+20$ °C ($+68$ °F)**Degree of protection**

Standard: IP 67 (NEMA 4X) for transmitter and sensor

Shock resistance

According to IEC 68-2-31

Vibration resistance

Acceleration up to 1 g, 10 to 150 Hz, following IEC 68-2-6

Electromagnetic compatibility (EMC)

As per IEC/EN 61326 and NAMUR recommendation NE 21

Operating conditions: Process

Fluid temperature range

Sensor

−40 to +140 °C (−40 to +284 °F)

Fluid pressure range (nominal pressure)

Flanges

- according to DIN PN 40 to 100
- according to ASME B16.5 Cl 150, Cl 300, Cl 600
- JIS 10K, 20K, 40K, 63K

Secondary containment:

The sensor Promass E has no secondary containment.

Rupture disk in the sensor housing (optional)

The sensor housing protects the inner electronics and mechanics and is filled with dry nitrogen. The housing of this sensor does not fulfill any additional secondary containment function. However, 15 bar (217.5 psi) can be specified as a reference value for the pressure loading capacity.

For increased safety, a version with rupture disk (triggering pressure 10 to 15 bar (145 to 217.5 psi)) can be used, which is available for order as a separate option.

Further information →  29.

Limiting flow

See information in the "Measuring range" section →  4

Select nominal diameter by optimizing between required flow range and permissible pressure loss. See the "Measuring range" section for a list of maximum possible full scale values.

- The minimum recommended full scale value is approx. 1/20 of the max. full scale value.
- In most applications, 20 to 50% of the maximum full scale value can be considered ideal
- Select a lower full scale value for abrasive substances such as fluids with entrained solids (flow velocity <1 m/s (< 3 ft/s)).
- For gas measurement the following rules apply:
 - Flow velocity in the measuring tubes should not be more than half the sonic velocity (0.5 Mach).
 - The maximum mass flow depends on the density of the gas: formula →  4

Pressure loss

Pressure loss depends on the fluid properties and on the flow rate. The following formulae can be used to approximately calculate the pressure loss:

Reynolds number	$Re = \frac{2 \cdot \dot{m}}{\pi \cdot d \cdot v \cdot \rho}$	a0004623
$Re \geq 2300^{1)}$	$\Delta p = K \cdot v^{0.25} \cdot \dot{m}^{1.85} \cdot \rho^{-0.86}$	a0004626
$Re < 2300$	$\Delta p = K1 \cdot v \cdot \dot{m} + \frac{K2 \cdot v^{0.25} \cdot \dot{m}^2}{\rho}$	a0004628
Δp = pressure loss [mbar] v = kinematic viscosity [m ² /s] \dot{m} = mass flow [kg/s]		
ρ = fluid density [kg/m ³] d = inside diameter of measuring tubes [m] K to $K2$ = constants (depending on nominal diameter)		
¹⁾ To compute the pressure loss for gases, always use the formula for $Re \geq 2300$.		

Pressure loss coefficients

DN	d [m]	K	K1	K2
8	$5.35 \cdot 10^{-3}$	$5.70 \cdot 10^7$	$7.91 \cdot 10^7$	$2.10 \cdot 10^7$
15	$8.30 \cdot 10^{-3}$	$7.62 \cdot 10^6$	$1.73 \cdot 10^7$	$2.13 \cdot 10^6$
25	$12.00 \cdot 10^{-3}$	$1.89 \cdot 10^6$	$4.66 \cdot 10^6$	$6.11 \cdot 10^5$
40	$17.60 \cdot 10^{-3}$	$4.42 \cdot 10^5$	$1.35 \cdot 10^6$	$1.38 \cdot 10^5$
50	$26.00 \cdot 10^{-3}$	$8.54 \cdot 10^4$	$4.02 \cdot 10^5$	$2.31 \cdot 10^4$
80	$40.50 \cdot 10^{-3}$	$1.44 \cdot 10^4$	$5.00 \cdot 10^5$	$2.30 \cdot 10^4$

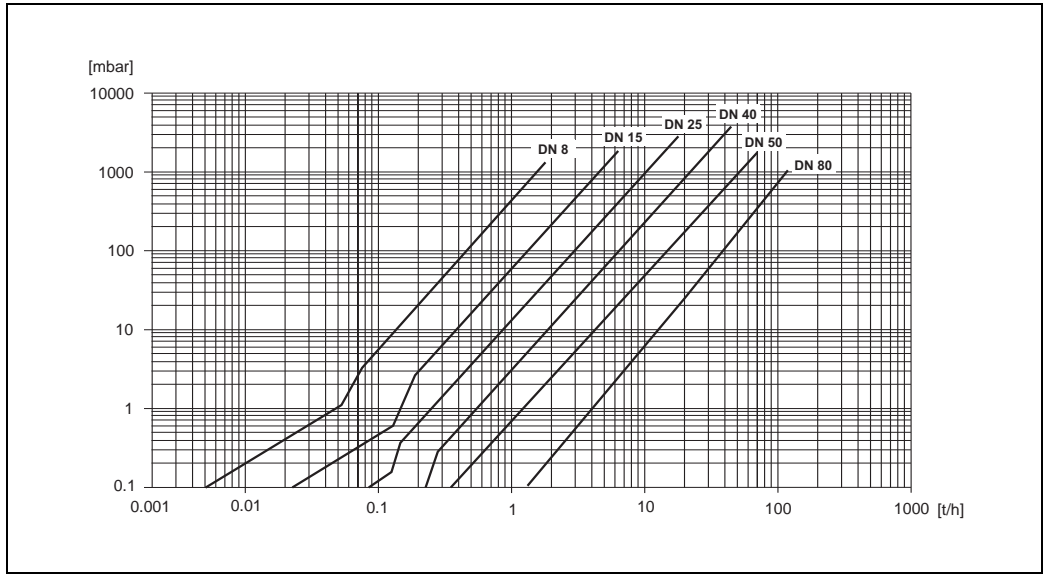

Pressure loss diagram for water

Pressure loss (US units)

Pressure loss is dependent on fluid properties nominal diameter. Consult Endress+Hauser for Applicator PC software to determine pressure loss in US units. All important instrument data is contained in the Applicator software program in order to optimize the design of measuring system. The software is used for following calculations:

- Nominal diameter of the sensor with fluid characteristics such as viscosity, density, etc.
- Pressure loss downstream of the measuring point.
- Converting mass flow to volume flow, etc.
- Simultaneous display of various meter size.
- Determining measuring ranges.

The Applicator runs on any IBM compatible PC with windows.

Mechanical construction

Design, dimensions

Dimensions:	
Field housing compact version, powder-coated die-cast aluminum	→ 17
Process connections in SI units	
Flange connections EN (DIN)	→ 18
Flange connections ASME B16.5	→ 19
Flange connections JIS	→ 20
VCO connections	→ 21
Tri-Clamp	→ 22
DIN 11851 (threaded hygienic connection)	→ 23
DIN 11864-1 Form A (threaded hygienic connection)	→ 23
DIN 11864-2 Form A (flat flange with groove)	→ 24
ISO 2853 (threaded hygienic connection)	→ 25
SMS 1145 (threaded hygienic connection)	→ 25
Process connections in US units	
Flange connections ASME B16.5	→ 26
VCO connections	→ 27
Tri-Clamp	→ 28
SMS 1145 (threaded hygienic connection)	→ 29
Rupture disk	→ 29

Field housing compact version, powder-coated die-cast aluminum

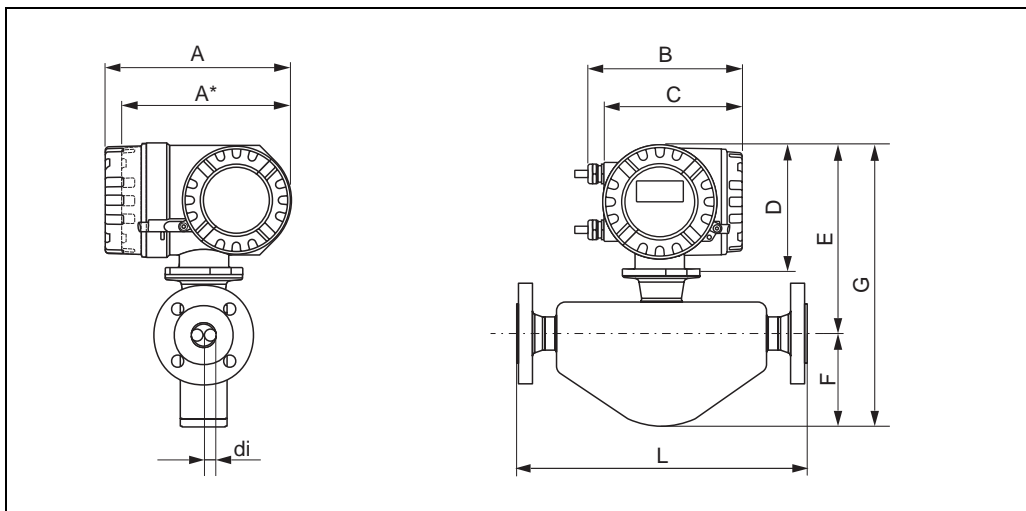

Dimensions SI units

DN	A	A*	B	C	D	E	F	G	L	di
8	227	207	187	168	160	224	93	317	1)	1)
15	227	207	187	168	160	226	105	331	1)	1)
25	227	207	187	168	160	231	106	337	1)	1)
40	227	207	187	168	160	237	121	358	1)	1)
50	227	207	187	168	160	253	170	423	1)	1)
80	227	207	187	168	160	282	205	487	1)	1)

¹⁾ dependent on respective process connection

* Blind version (without local display)

All dimensions in [mm]

Dimensions in US units

DN	A	A*	B	C	D	E	F	G	L	di
3/8"	9.08	8.28	7.48	6.72	6.40	8.82	3.66	12.48	2)	2)
1/2"	9.08	8.28	7.48	6.72	6.40	8.90	4.13	13.03	2)	2)
1"	9.08	8.28	7.48	6.72	6.40	9.09	4.17	13.27	2)	2)
1 1/2"	9.08	8.28	7.48	6.72	6.40	9.33	4.76	14.09	2)	2)
2"	9.08	8.28	7.48	6.72	6.40	9.96	6.69	16.65	2)	2)
3"	9.08	8.28	7.48	6.72	6.40	11.10	8.07	19.17	2)	2)

¹⁾ dependent on respective process connection

* Blind version (without local display)

All dimensions in [inch]

Process connection in SI units

Flange connections EN (DIN), ASME B16.5, JIS

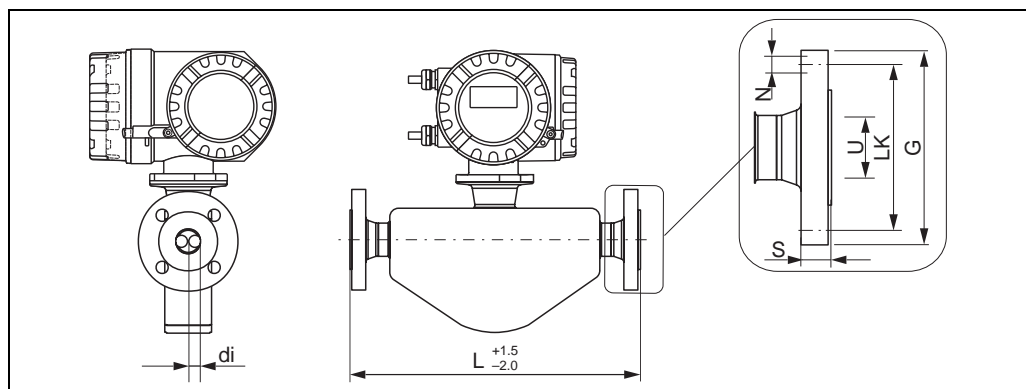

a0004640-en

Flange connections EN (DIN)

Flange according to EN 1092-1 (DIN 2501 / DIN 2512N ¹⁾) / PN 40: 1.4404/316L							
Surface roughness (flange): EN 1092-1 Form B1 (DIN 2526 Form C), Ra 3.2 to 12.5 µm							
DN	G	L	N	S	LK	U	di
8	95	232	4 × Ø14	16	65	17.3	5.35
15	95	279	4 × Ø14	16	65	17.3	8.30
25	115	329	4 × Ø14	18	85	28.5	12.0
40	150	445	4 × Ø18	18	110	43.1	17.6
50	165	556	4 × Ø18	20	125	54.5	26.0
80	200	610	8 × Ø18	24	160	82.5	40.5

¹⁾ Flange with groove according to EN 1092-1 Form D (DIN 2512N) available
All dimensions in [mm]

Flange according to EN 1092-1 (DIN 2501) / PN 40 (with DN 25-flanges): 1.4404/316L							
Surface roughness (flange): EN 1092-1 Form B1 (DIN 2526 Form C), Ra 3.2 to 12.5 µm							
DN	G	L	N	S	LK	U	di
8	115	329	4 × Ø14	18	85	28.5	5.35
15	115	329	4 × Ø14	18	85	28.5	8.30

All dimensions in [mm]

Flange according to EN 1092-1 (DIN 2501 / DIN 2512N ¹⁾) / PN 63: 1.4404/316L							
Surface roughness (flange): EN 1092-1 Form B1 (DIN 2526 Form C), Ra 0.8 to 3.2 µm							
DN	G	L	N	S	LK	U	di
50	180	565	4 × Ø22	26	135	54,5	26,0
80	215	650	8 × Ø22	28	170	81,7	40,5

¹⁾ Flange with groove according to EN 1092-1 Form D (DIN 2512N) available
All dimensions in [mm]

Flange EN 1092-1 (DIN 2501 / DIN 2512N ¹⁾) / PN 100: 1.4404/316L							
Surface roughness (flange): EN 1092-1 Form B1 (DIN 2526 Form C), Ra 0.8 to 3.2 µm							
DN	G	L	N	S	LK	U	di
8	105	261	4 × Ø14	20	75	17.3	5.35
15	105	295	4 × Ø14	20	75	17.3	8.30
25	140	360	4 × Ø18	24	100	28.5	12.0
40	170	486	4 × Ø22	26	125	42.5	17.6
50	195	581	4 × Ø26	28	145	53.9	26.0
80	230	660	8 × Ø26	32	180	80.9	40.5

¹⁾ Flange with groove to EN 1092-1 Form D (DIN 2512N) available
All dimensions in [mm]

Flange connections ASME B16.5

Flange according to ASME B16.5 / CI 150: 1.4404/316L							
DN	G	L	N	S	LK	U	di
8	88.9	232	4 × Ø15.7	11.2	60.5	15.7	5.35
15	88.9	279	4 × Ø15.7	11.2	60.5	15.7	8.30
25	108.0	329	4 × Ø15.7	14.2	79.2	26.7	12.0
40	127.0	445	4 × Ø15.7	17.5	98.6	40.9	17.6
50	152.4	556	4 × Ø19.1	19.1	120.7	52.6	26.0
80	190.5	610	4 × Ø19.1	23.9	152.4	78.0	40.5

All dimensions in [mm]

Flange according to ASME B16.5 / CI 300: 1.4404/316L							
DN	G	L	N	S	LK	U	di
8	95.2	232	4 × Ø15.7	14.2	66.5	15.7	5.35
15	95.2	279	4 × Ø15.7	14.2	66.5	15.7	8.30
25	123.9	329	4 × Ø19.0	17.5	88.9	26.7	12.0
40	155.4	445	4 × Ø22.3	20.6	114.3	40.9	17.6
50	165.1	556	8 × Ø19.0	22.3	127.0	52.6	26.0
80	209.5	610	8 × Ø22.3	28.4	168.1	78.0	40.5

All dimensions in [mm]

Flange according to ASME B16.5 / CI 600: 1.4404/316L							
DN	G	L	N	S	LK	U	di
8	95.3	261	4 × Ø15.7	20.6	66.5	13.9	5.35
15	95.3	295	4 × Ø15.7	20.6	66.5	13.9	8.30
25	124.0	380	4 × Ø19.1	23.9	88.9	24.3	12.0
40	155.4	496	4 × Ø22.4	28.7	114.3	38.1	17.6
50	165.1	583	8 × Ø19.1	31.8	127.0	49.2	26.0
80	209.6	672	8 × Ø22.4	38.2	168.1	73.7	40.5

All dimensions in [mm]

Flange connections JIS

Flange JIS B2220 / 10K: SUS 316L							
DN	G	L	N	S	LK	U	di
50	155	556	4 × Ø19	16	120	50	26.0
80	185	605	8 × Ø19	18	150	80	40.5

All dimensions in [mm]

Flange JIS B2220 / 20K: SUS 316L							
DN	G	L	N	S	LK	U	di
8	95	232	4 × Ø15	14	70	15	5.35
15	95	279	4 × Ø15	14	70	15	8.30
25	125	329	4 × Ø19	16	90	25	12.0
40	140	445	4 × Ø19	18	105	40	17.6
50	155	556	8 × Ø19	18	120	50	26.0
80	200	605	8 × Ø23	22	160	80	40.5

All dimensions in [mm]

Flange JIS B2220 / 40K: SUS 316L							
DN	G	L	N	S	LK	U	di
8	115	261	4 × Ø19	20	80	15	5.35
15	115	300	4 × Ø19	20	80	15	8.30
25	130	375	4 × Ø19	22	95	25	12.0
40	160	496	4 × Ø23	24	120	38	17.6
50	165	601	8 × Ø19	26	130	50	26.0
80	210	662	8 × Ø23	32	170	75	40.5

All dimensions in [mm]

Flange JIS B2220 / 63K: SUS 316L							
DN	G	L	N	S	LK	U	di
8	120	282	4 × Ø19	23	85	12	5.35
15	120	315	4 × Ø19	23	85	12	8.30
25	140	383	4 × Ø23	27	100	22	12.0
40	175	515	4 × Ø25	32	130	35	17.6
50	185	616	8 × Ø23	34	145	48	26.0
80	230	687	8 × Ø25	40	185	73	40.5

All dimensions in [mm]

VCO connections

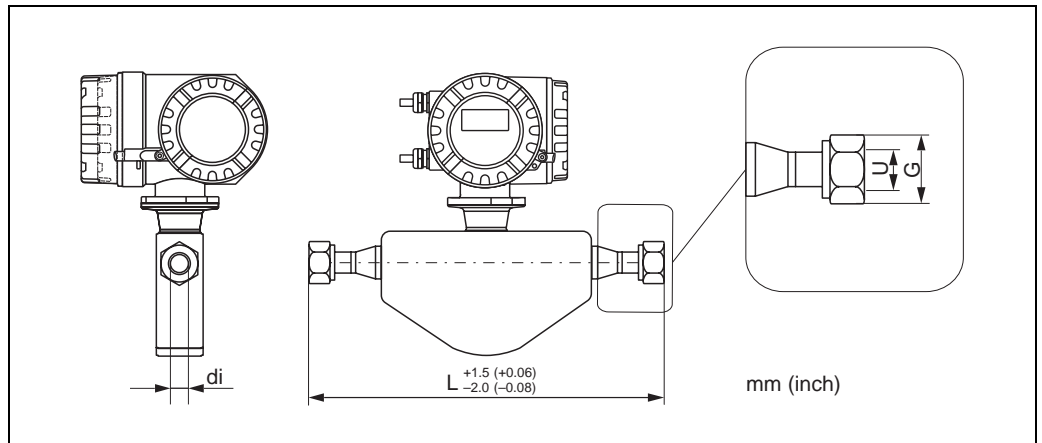

a0007641-ae

VCO connections: 1.4404/316L

DN	G	L	U	d_i
8	1" AF	252	10.2	5.35
15	1½" AF	305	15.7	8.30

All dimensions in [mm]

Tri-Clamp

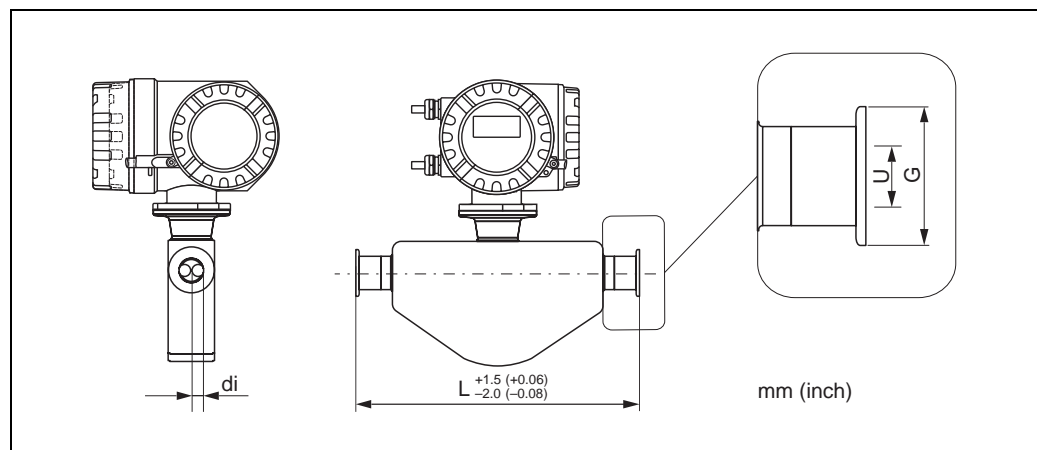

a0007643-ae

1", 1½", 2" -Tri-Clamp: 1.4404/316L					
DN	Clamp	G	L	U	di
8	1"	50.4	229	22.1	5.35
15	1"	50.4	273	22.1	8.30
25	1"	50.4	324	22.1	12.0
40	1½"	50.4	456	34.8	17.6
50	2"	63.9	562	47.5	26.0
80	3"	90.9	672	72.9	40.5

3A version also available (Ra ≤ 0.8 μm/150 grit.)
All dimensions in [mm]

½" -Tri-Clamp: 1.4404/316L					
DN	Clamp	G	L	U	di
8	½"	25.0	229	9.5	5.35
15	½"	25.0	273	9.5	8.30

3A version also available (Ra ≤ 0.8 μm/150 grit.)
All dimensions in [mm]

DIN 11851 (threaded hygienic connection)

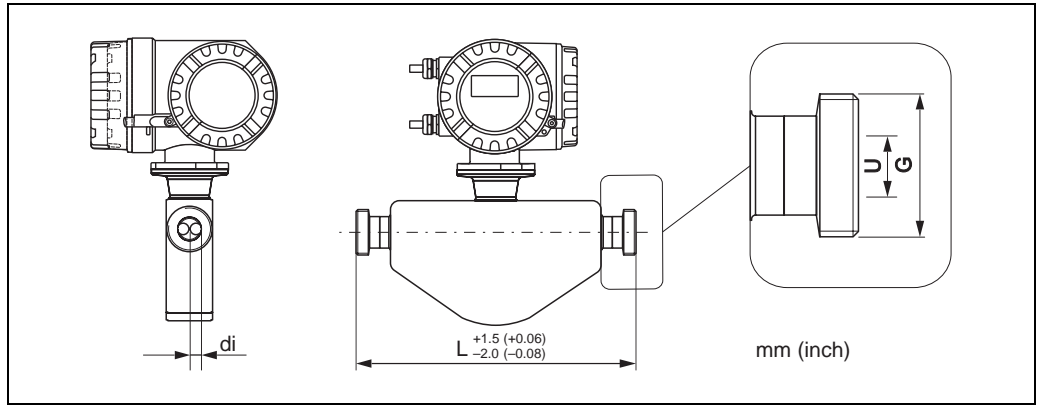

Threaded hygienic connection DIN 11851: 1.4404/316L

DN	G	L	U	di
8	Rd 34 × 1/8"	229	16	5.35
15	Rd 34 × 1/8"	273	16	8.30
25	Rd 52 × 1/6"	324	26	12.0
40	Rd 65 × 1/6"	456	38	17.6
50	Rd 78 × 1/6"	562	50	26.0
80	Rd 110 × 1/4"	672	81	40.5

3A version also available (Ra ≤ 0.8 µm/150 grit.); All dimensions in [mm]

DIN 11864-1 Form A (threaded hygienic connection)

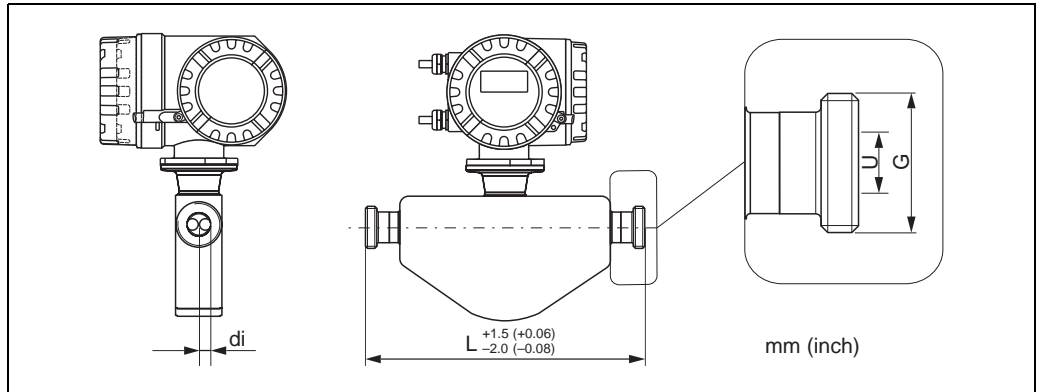

Threaded hygienic connection DIN 11864-1 Form A: 1.4404/316L

DN	G	L	U	di
8	Rd 28 × 1/8"	229	10	5.35
15	Rd 34 × 1/8"	273	16	8.30
25	Rd 52 × 1/6"	324	26	12.00
40	Rd 65 × 1/6"	456	38	17.60
50	Rd 78 × 1/6"	562	50	26.00
80	Rd 110 × 1/4"	672	81	40.5

3A version also available (Ra ≤ 0.8 µm/150 grit.); All dimensions in [mm]

DIN 11864-2 Form A (flat flange with groove)

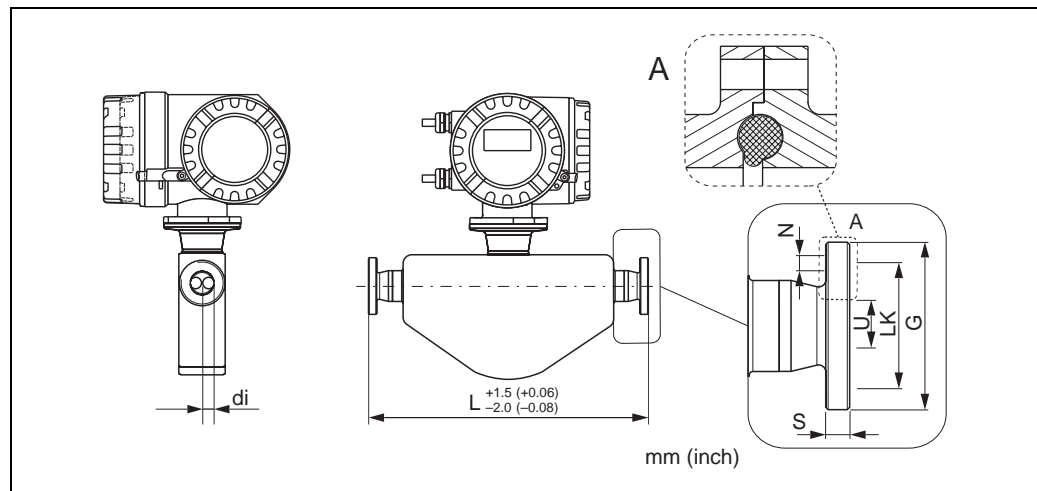

s0007649-02

DIN 11864-2 Form A (flat flange with groove): 1.4404/316L							
DN	G	L	N	S	LK	U	di
8	54	249	4 × Ø9	10	37	10	5.35
15	59	293	4 × Ø9	10	42	16	8.30
25	70	344	4 × Ø9	10	53	26	12.0
40	82	456	4 × Ø9	10	65	38	17.6
50	94	562	4 × Ø9	10	77	50	26.0
80	133	672	8 × Ø11	12	112	81	40.5

3A version also available (Ra ≤ 0.8 µm/150 grit.)

All dimensions in [mm]

ISO 2853 (threaded hygienic connection)

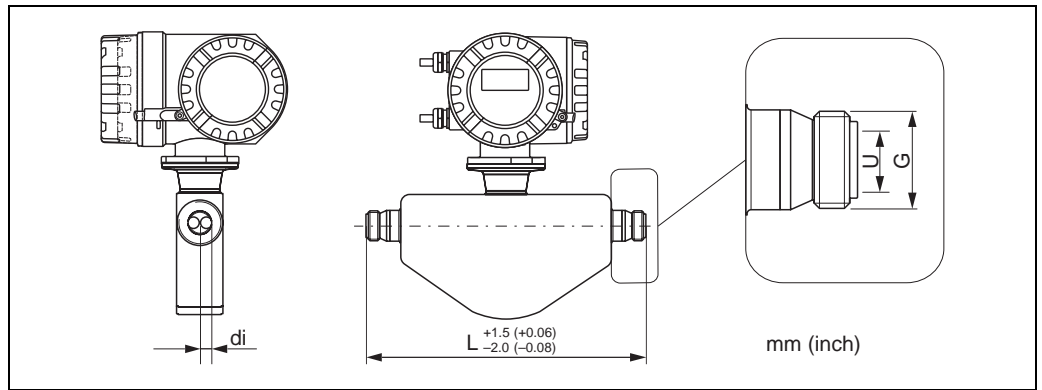

a0007651-ae

Threaded hygienic connection ISO 2853: 1.4404/316L

DN	G ¹⁾	L	U	di
8	37.13	229	22.6	5.35
15	37.13	273	22.6	8.30
25	37.13	324	22.6	12.0
40	50.68	456	35.6	17.6
50	64.16	562	48.6	26.0
80	91.19	672	72.9	40.5

¹⁾ Max. thread diameter to ISO 2853 Annex A; 3A version also available (Ra ≤ 0.8 µm/150 grit.)
All dimensions in [mm]

SMS 1145 (threaded hygienic connection)

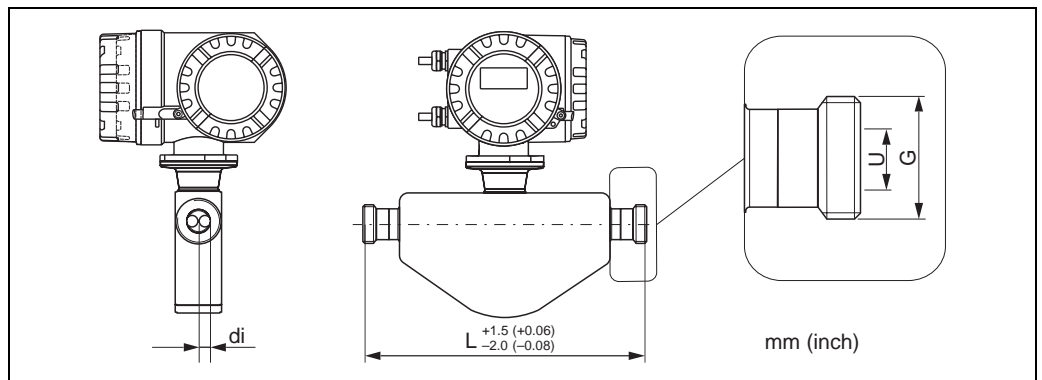

a0007653-ae

Threaded hygienic connection SMS 1145: 1.4404/316L

DN	G	L	U	di
8	Rd 40 × 1/6"	229	22.5	5.35
15	Rd 40 × 1/6"	273	22.5	8.30
25	Rd 40 × 1/6"	324	22.5	12.0
40	Rd 60 × 1/6"	456	35.5	17.6
50	Rd 70 × 1/6"	562	48.5	26.0
80	Rd 98 × 1/6"	672	72.9	40.5

3A version also available (Ra ≤ 0.8 µm/150 grit.); All dimensions in [mm]

Process connections in US units

Flange connections ASME B16.5

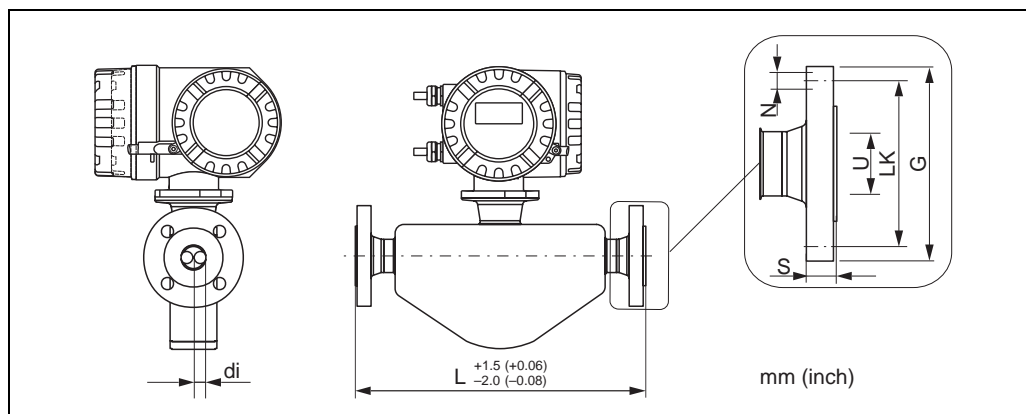

s0007640-02

Flange according to ASME B16.5 / Cl 150: 1.4404/316L							
DN	G	L	N	S	LK	U	di
3/8"	3.50	9.13	4 × Ø0.62	0.44	2.38	0.62	0.21
1/2"	3.50	10.98	4 × Ø0.62	0.44	2.38	0.62	0.33
1"	4.25	12.95	4 × Ø0.62	0.56	3.12	1.05	0.47
1 1/2"	5.00	17.52	4 × Ø0.62	0.69	3.88	1.61	0.69
2"	6.00	21.89	4 × Ø0.75	0.75	4.75	2.07	1.02
3"	7.50	24.02	4 × Ø0.75	0.94	6.00	3.07	1.59

All dimensions in [inch]

Flange according to ASME B16.5 / Cl 300: 1.4404/316L							
DN	G	L	N	S	LK	U	di
3/8"	3.75	9.13	4 × Ø0.62	0.56	2.62	0.62	0.21
1/2"	3.75	10.98	4 × Ø0.62	0.56	2.62	0.62	0.33
1"	4.88	12.95	4 × Ø0.75	0.69	3.50	1.05	0.47
1 1/2"	6.12	17.52	4 × Ø0.88	0.81	4.50	1.61	0.69
2"	6.50	21.89	4 × Ø0.75	0.88	5.00	2.07	1.02
3"	8.25	24.02	8 × Ø0.88	1.12	6.62	3.07	1.59

All dimensions in [inch]

Flange according to ASME B16.5 / Cl 600: 1.4404/316L							
DN	G	L	N	S	LK	U	di
3/8"	3.75	10.28	4 × Ø0.62	0.81	2.62	0.55	0.21
1/2"	3.75	11.61	4 × Ø0.62	0.81	2.62	0.55	0.33
1"	4.88	14.96	4 × Ø0.75	0.94	3.50	0.96	0.47
1 1/2"	6.12	19.53	4 × Ø0.88	1.13	4.50	1.50	0.69
2"	6.50	22.95	4 × Ø0.75	1.25	5.00	1.94	1.02
3"	8.25	24.46	8 × Ø0.88	1.50	6.62	2.90	1.59

All dimensions in [inch]

VCO connections

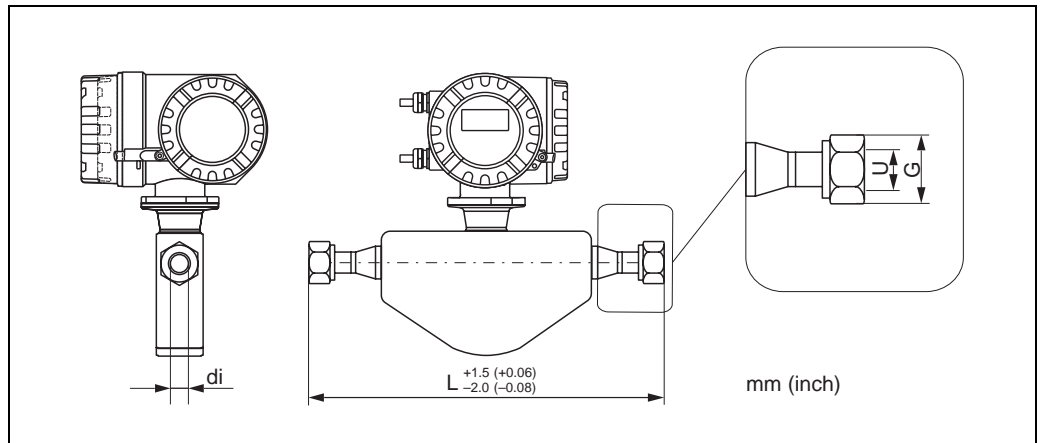

a0007641-ae

VCO connections: 1.4404/316L				
DN	G	L	U	di
3/8"	1" AF	9.92	0.40	0.21
1/2"	1 1/2" AF	12.01	0.62	0.33

All dimensions in [inch]

Tri-Clamp

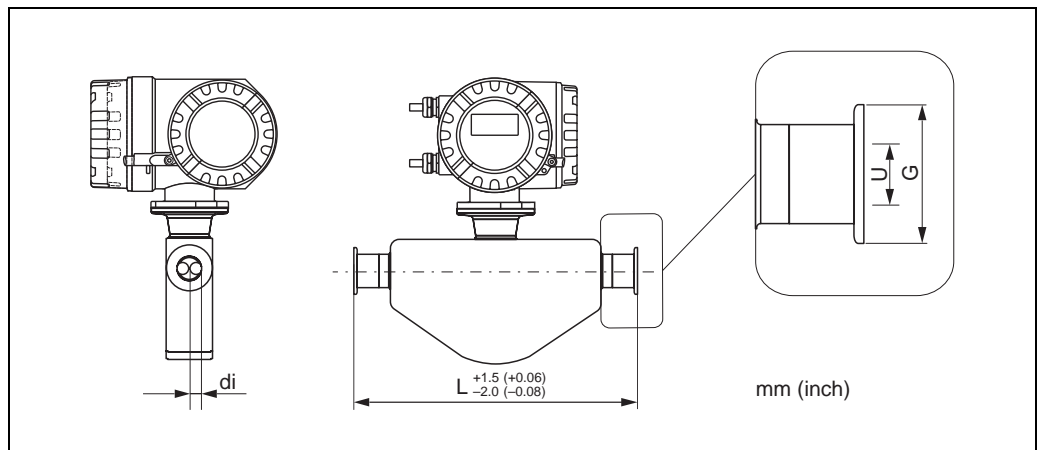

a0007643-ae

1", 1½", 2" -Tri-Clamp: 1.4404/316L					
DN	Clamp	G	L	U	di
3/8"	1"	1.98	9.02	0.87	0.21
½"	1"	1.98	10.75	0.87	0.33
1"	1"	1.98	12.76	0.87	0.47
1½"	1½"	1.98	17.95	1.37	0.69
2"	2"	2.52	22.13	1.87	1.02
3"	3"	3.58	26.46	2.87	1.59

3A version also available (Ra ≤ 30 µin/150 grit.)
All dimensions in [inch]

½" -Tri-Clamp: 1.4404/316L					
DN	Clamp	G	L	U	di
3/8"	½"	0.98	9.02	0.37	0.21
½"	½"	0.98	10.75	0.37	0.33

3A version also available (Ra ≤ 30 µin/150 grit.)
All dimensions in [inch]

SMS 1145 (threaded hygienic connection)

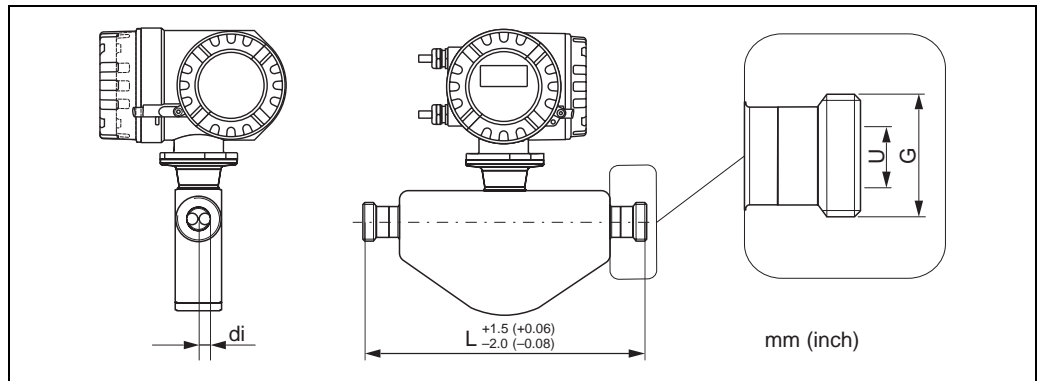

a0007653-ae

Threaded hygienic connection SMS 1145: 1.4404/316L				
DN	G	L	U	d_i
3/8"	Rd 40 × 1/6"	9.02	0.89	0.21
1/2"	Rd 40 × 1/6"	10.75	0.89	0.33
1"	Rd 40 × 1/6"	12.76	0.89	0.47
1 1/2"	Rd 60 × 1/6"	17.95	1.40	0.69
2"	Rd 70 × 1/6"	22.13	1.91	1.02
3"	Rd 98 × 1/6"	26.46	2.87	1.59

3A version also available ($R_a \leq 30 \mu\text{m}/150 \text{ grit.}$); All dimensions in [inch]

Rupture disk

Sensor housings with integrated rupture disks are optionally available.



Warning!

- Make sure that the function and operation of the rupture disk is not impeded through the installation. Triggering overpressure in the housing as stated on the indication label. Take adequate precautions to ensure that no damage occurs, and risk to human life is ruled out, if the rupture disk is triggered. Rupture disk: Burst pressure 10 to 15 bar (145 to 217.5 psi).
- Please note that the housing can no longer assume a secondary containment function if a rupture disk is used.
- It is not permitted to open the connections or remove the rupture disk.



Caution!

Rupture disks can not be combined with separately available heating jacket.



Note!

- Before commissioning, please remove the transport protection of the rupture disk.
- Please note the indication labels.



A0008788

Indication label for the rupture disk

Weight**Weight in SI units**

DN [mm]	8	15	25	40	50	80
Compact version	8	8	10	15	22	31

All values (weight) refer to devices with EN/DIN PN 40 flanges.
Weight information in [lb]

Weight in US units

DN [inch]	3/8"	1/2"	1"	1 1/2"	2"	3"
Compact version	18	18	22	33	49	69

All values (weight) refer to devices with EN/DIN PN 40 flanges.
Weight information in [lb]

Materials**Transmitter housing**

- Powder coated die-cast aluminum
- Window material: glass or polycarbonate

Sensor housing / containment

- Acid and alkali-resistant outer surface
- Stainless steel 1.4301/304

Process connections

- Stainless steel 1.4404/316L
 - Flanges according to EN 1092-1 (DIN 2501) and according to ASME B16.5
 - DIN 11864-2 Form A (flat flange with groove)
 - Threaded hygienic connection: DIN 11851, SMS 1145, ISO 2853, DIN 11864-1 Form A
 - VCO connections
- Stainless steel SUS 316L
 - Flanges to JIS B2220

Measuring tubes

- Stainless steel EN 1.4539 / ASTM 904L
- Finish quality: $Ra_{max} \leq 0.8 \mu\text{m}/150 \text{ grit}$ (30 $\mu\text{in}/150 \text{ grit}$)

Seals

Welded process connections without internal seals

Material load curves



Warning!

The following material load curves refer to the entire sensor and not just the process connection.

Flange connection according to EN 1092-1 (DIN 2501)

Flange material: 1.4404/316L

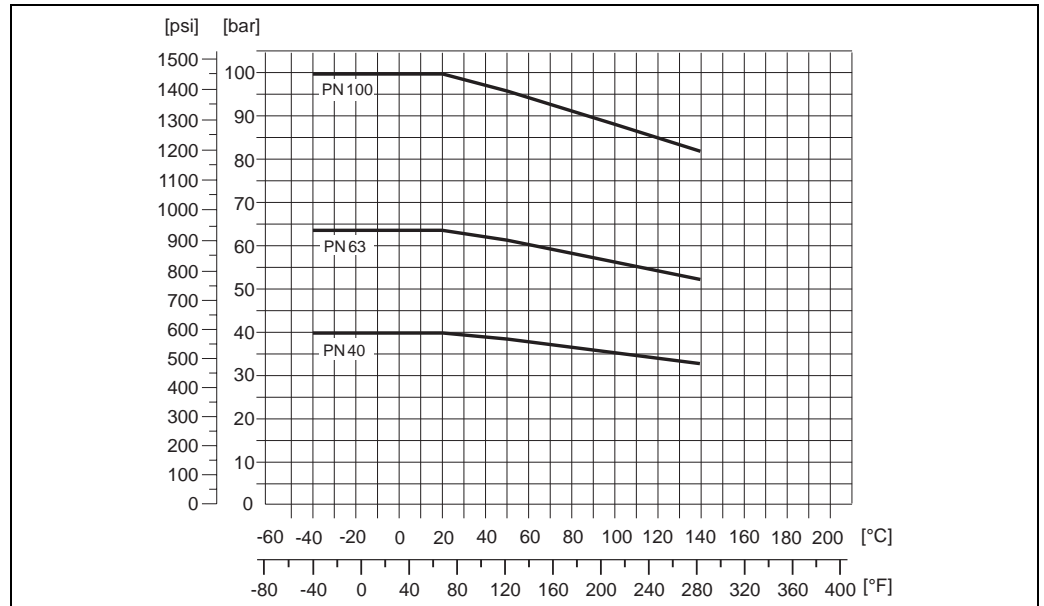

a0006904-ae

Flange connection according to ASME B16.5

Flange material: 1.4404/316L

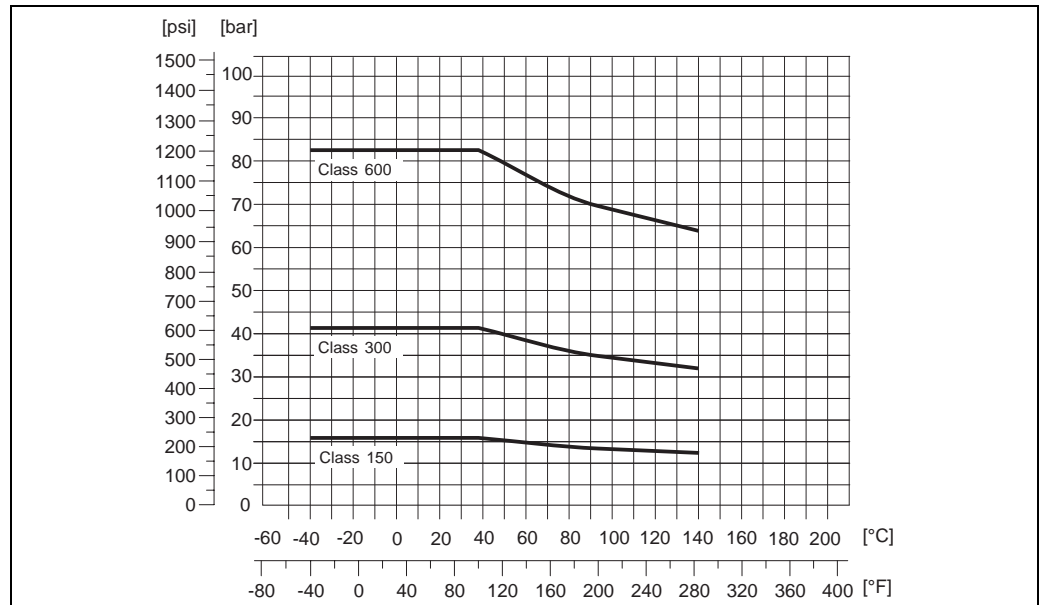

a0006905-ae

Flange connection to JIS B2220

Flange material: 1.4404/316L

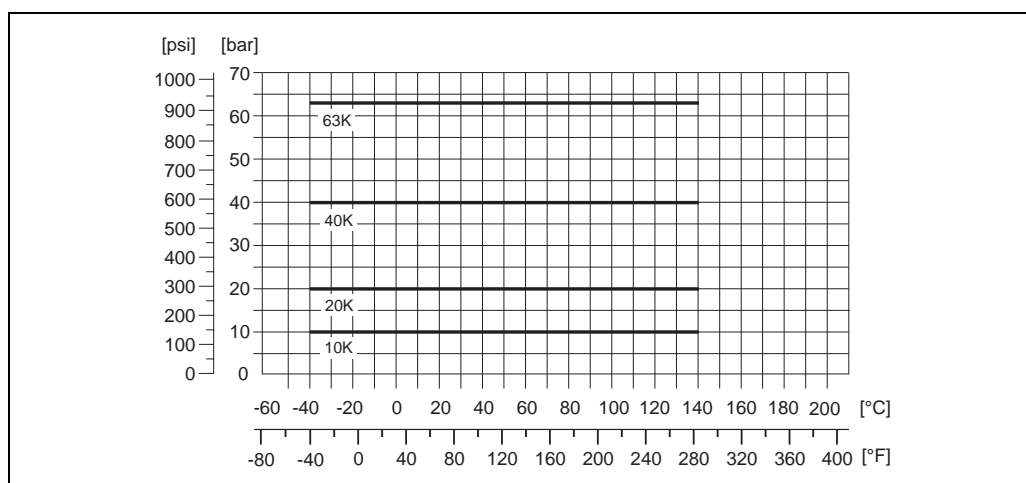

A0006908-ae

VCO process connection

Flange material: 1.4404/316L

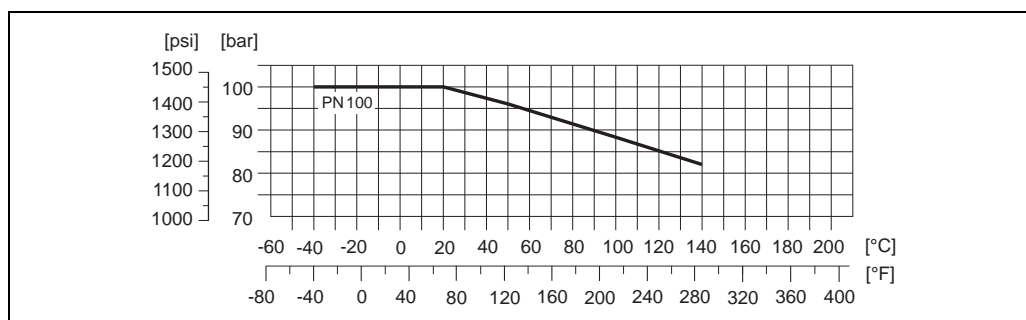

A0006908-ae

Tri-Clamp process connection

The Clamp connections are suited up to a maximum pressure of 16 bar (232 psi). Please observe the operating limits of the clamp and seal used as they could be under 16 bar (232 psi). The clamp and the seal are not included in the scope of supply.

Process connection to DIN 11851

Connection material: 1.4404/316L

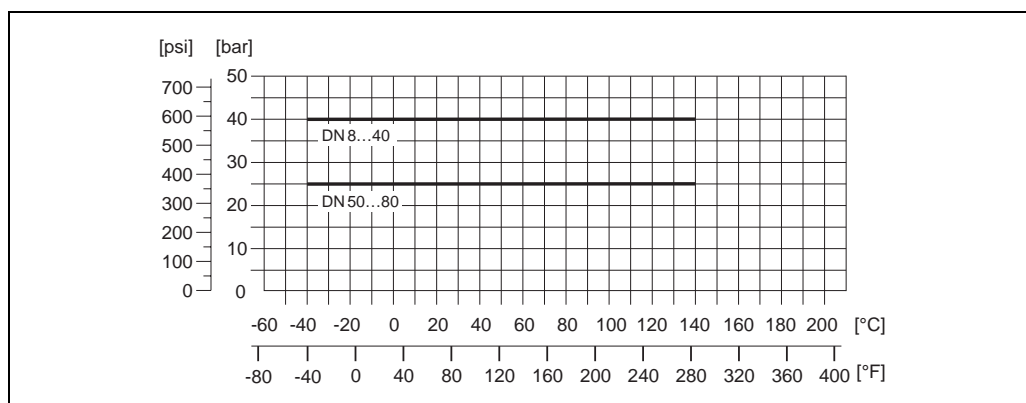

A0006909-ae

DIN 11851 allows for applications up to +140 °C (+284 °F) if suitable sealing materials are used. Please take this into account when selecting seals and counterparts as these components can limit the pressure and temperature range.

Process connection to SMS 1145

Connection material: 1.4404/316L

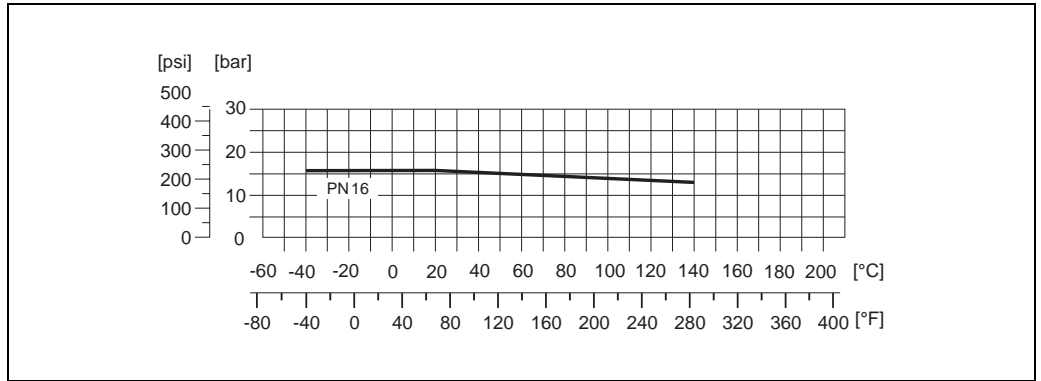

SMS 1145 allows for applications up to 6 bar (87 psi) if suitable sealing materials are used. Please take this into account when selecting seals and counterparts as these components can limit the pressure and temperature range.

DIN 11864-1 Form A (threaded hygienic connection)

Connection material: 1.4404/316L

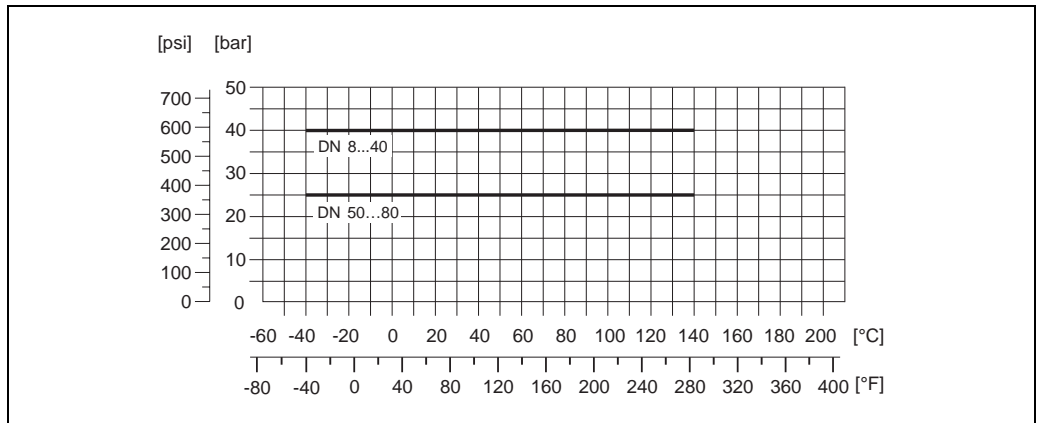

DIN 11864-2 Form A (flat flange with groove)

Flange material: 1.4404/316L

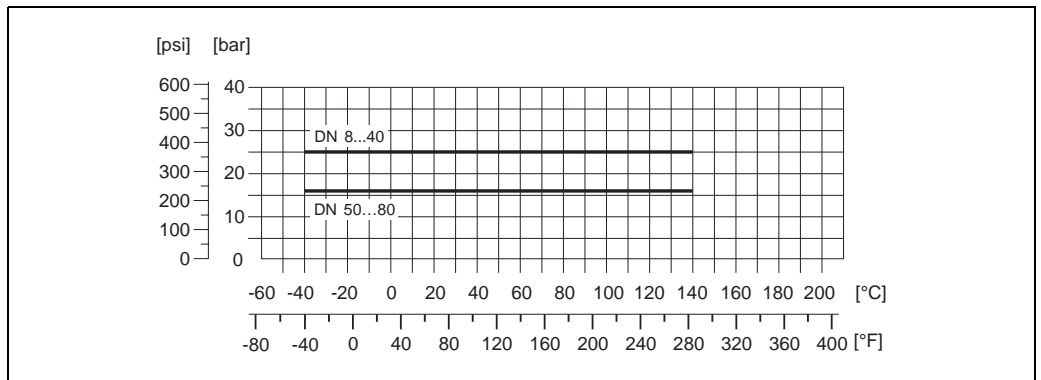

Threaded hygienic connection to ISO 2853

Connection material: 1.4404/316L

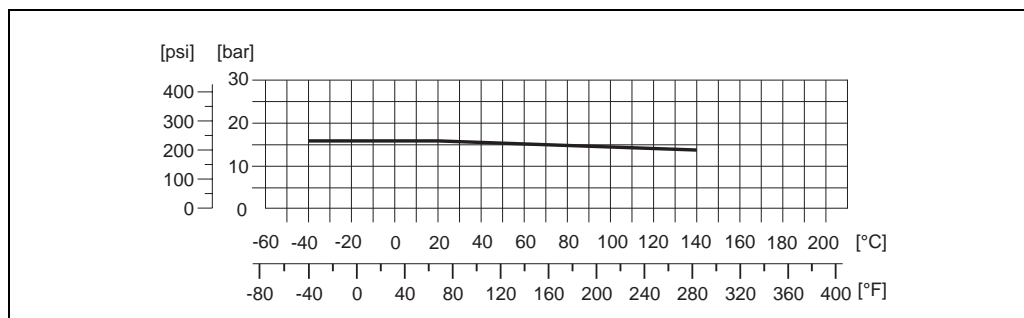

A0006912-02

Process connections**Welded process connections**

- Flanges according to EN 1092-1 (DIN 2501), according to ASME B16.5, JIS B2220, VCO connections
- Sanitary connections: Tri-Clamp, threaded hygienic connections (DIN 11851, SMS 1145, ISO 2853, DIN 11864-1), DIN 11864-2 Form A (flat flange with groove)

Human interface**Display elements**

- Liquid-crystal display: backlit, two lines with 16 characters per line
- Selectable display of different measured values and status variables
- At ambient temperatures below -20 °C (-4 °F) the readability of the display may be impaired.

Languages

Display languages: French, Spanish, Italian, Dutch, Portuguese, German, English

Remote operation

- HART protocol (handheld communicator)
- Configuration and service software or "FieldCare" from Endress+Hauser
- AMS configuration programs (Fisher Rosemount), SIMATIC PDM (Siemens)

Certificates and approvals**CE mark**

The measuring system is in conformity with the statutory requirements of the EC Directives. Endress+Hauser confirms successful testing of the device by affixing to it the CE mark.

C-Tick symbol

The measuring system complies with the EMC requirements of the "Australian Communications and Media Authority (ACMA)"

Ex approval

Information about currently available Ex versions (ATEX, FM, CSA, IECEx, NEPSI etc.) can be supplied by your Endress+Hauser Sales Center on request. All information relevant to explosion protection is available in separate Ex documents that you can order as necessary.

Hygienic compatibility

3A approval

Other standards and guidelines

- EN 60529
Degrees of protection by housing (IP code)
- EN 61010-1
Protection Measures for Electrical Equipment for Measurement, Control, Regulation and Laboratory Procedures.
- IEC/EN 61326
"Emission in accordance with Class A requirements". Electromagnetic compatibility (EMC requirements)
- NAMUR NE 21
Electromagnetic compatibility (EMC) of industrial process and laboratory control equipment.
- NAMUR NE 43
Standardization of the signal level for the breakdown information of digital transmitters with analog output signal.
- NAMUR NE 53
Software of field devices and signal-processing devices with digital electronics

Pressure Equipment Directive

Measuring devices with a nominal diameter smaller than or equal to DN 25 correspond to Article 3(3) of the EC Directive 97/23/EC (Pressure Equipment Directive) and have been designed and manufactured according to good engineering practice. For larger nominal diameters, optional approvals according to Cat. II/III are available when required (depends on fluid and process pressure).

Ordering Information

The Endress+Hauser service organization can provide detailed ordering information and information on the order codes upon request.

Accessories

Various accessories, which can be ordered separately from Endress+Hauser, are available for the transmitter and the sensor.

Documentation

- Flow measuring technology (FA005D)
- Operating Instructions/Description of Device Functions
 - Promass 40 HART (BA061D/BA062D)
- Supplementary documentation on Ex-ratings: ATEX, FM, CSA, IECEx NEPSI

Registered trademarks

TRI-CLAMP®

Registered trademark of Ladish & Co., Inc., Kenosha, WI, USA

HART®

Registered trademark of HART Communication Foundation, Austin, TX, USA

HistoROM™, S-DAT®, T-DAT™, F-CHIP®, Fieldcheck®, FieldCare®, Applicator®

Registered or registration-pending trademarks of Endress+Hauser Flowtec AG, Reinach, CH

Instruments International

Endress+Hauser
Instruments International AG
Kaegenstrasse 2
4153 Reinach
Switzerland

Tel. +41 61 715 81 00
Fax +41 61 715 25 00
www.endress.com
info@ii.endress.com

Endress+Hauser 
People for Process Automation