

Technical Datasheet



Magnetic Horizontal Level Switches

Weatherproof Aluminium-bronze and Stainless Steel Wetside models

Key Features

- Operates in almost every liquid, even at high pressure or temperature
- Tough, rugged design for long life in aggressive environments
- Magnetically coupled
- No glands or linkages that could cause leaks



Series Overview

The Mobrey magnetic horizontal float switch is ideal for high and low liquid level alarm, and pump control duties. It is designed to open or close a circuit as a changing liquid level within a vessel passes the level of the float.

When the process liquid level is below the switch point, contacts B-B are made and contacts A-A are open, but if the liquid level is above the switch point, contacts A-A are made and contacts B-B are open.

This proven design with over 100 year of experience, allows for fit and forget of the instrument.

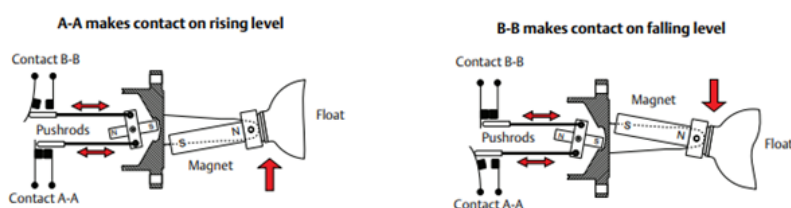

Other products

Other products we can offer :

- Vertical level switches
- 003 Gap Sensor

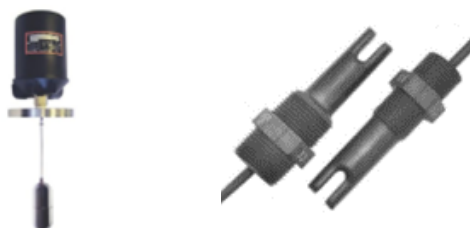

Product applications

- High and low liquid level alarm
- Direct (side or top) or chamber mounting
- Pump control duty
- Interface duty
- Dirty Liquids

How can we help you?

Delta Mobrey offers fast, efficient and knowledgeable support when and where you need it. Please visit our website at www.delta-mobrey.com to find your local support centre or call us on: **+44 (0)1252 729140**

How to order

Instrument can be configured by selecting codes representing the desired features from the tables that follow.

The chart below, describes how the model code is built up. For assistance in configuring a switch that best suits your needs, please contact your local sales office.

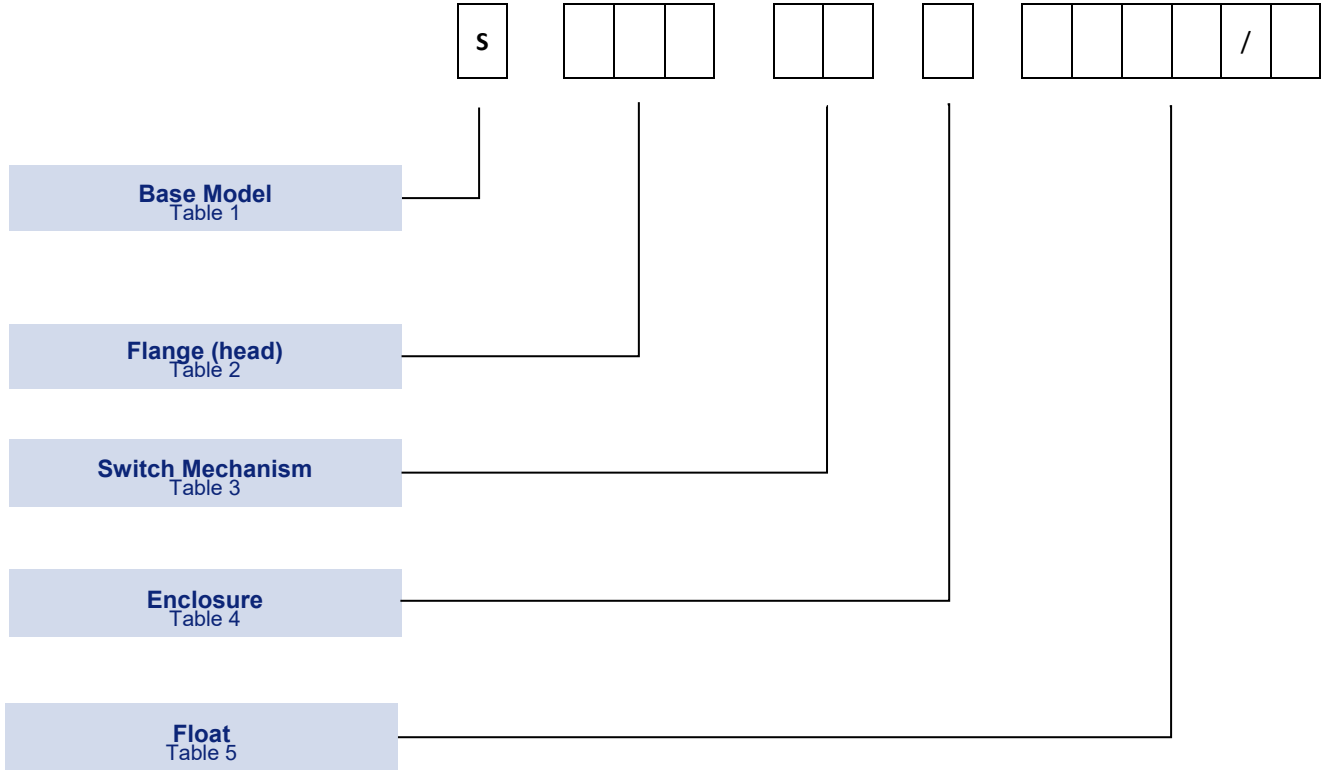

Models

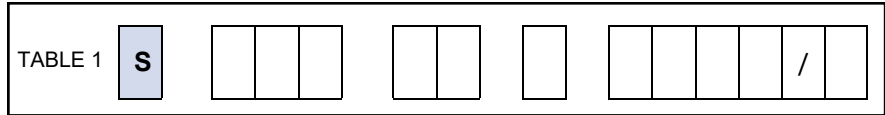

Description	Code
Horizontal float switch	S

Flange (head) ⁽¹⁾

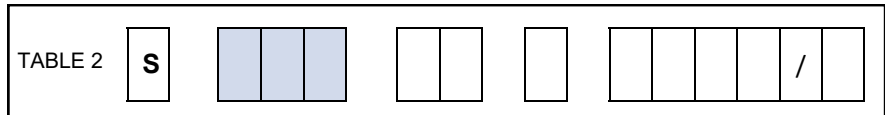

Description	Max T process ⁽²⁾	Code
General purpose, aluminium bronze wetside, Mobrey 'A' flange, 261 psi (18 bar)	410 °F (210 °C)	01
General purpose, stainless steel wetside, Mobrey 'A' flange, 490 psi (33.8 bar)	752 °F (400 °C)	36 ^{(3), (4)}
General purpose, stainless steel wetside, Mobrey 'A' flange, 490 psi (33.8 bar)	356 °F (180 °C)	190 ^{(3), (4), (5)}
General purpose, stainless steel wetside, 3 in. ASME B16.5 Class 150 RF flange	752 °F (400 °C)	440
General purpose, stainless steel wetside, 4 in. ASME B16.5 Class 150 RF flange	752 °F (400 °C)	441
General purpose, stainless steel wetside, 3 in. ASME B16.5 Class 300 RF flange	752 °F (400 °C)	424
General purpose, stainless steel wetside, 4 in. ASME B16.5 Class 300 RF flange	752 °F (400 °C)	425
General purpose, stainless steel wetside, 3 in. ASME B16.5 Class 600 RF flange	752 °F (400 °C)	489
General purpose, stainless steel wetside, 3 in. ASME B16.5 Class 900 RF flange	752 °F (400 °C)	490
General purpose, stainless steel wetside, EN 1092-1 DN 65 PN 16 (4 bolt hole) flange	752 °F (400 °C)	428
General purpose, stainless steel wetside, EN 1092-1 DN 80 PN 16 flange	752 °F (400 °C)	429
General purpose, stainless steel wetside, EN 1092-1 DN 100 PN 16 flange	752 °F (400 °C)	430
General purpose, stainless steel wetside, EN 1092-1 DN 125 PN 16 flange	752 °F (400 °C)	431
General purpose, stainless steel wetside, EN 1092-1 DN 150 PN 16 flange	752 °F (400 °C)	432
General purpose, stainless steel wetside, EN 1092-1 DN 65 PN 40 flange	752 °F (400 °C)	417
General purpose, stainless steel wetside, EN 1092-1 DN 80 PN 40 flange	752 °F (400 °C)	418
General purpose, stainless steel wetside, EN 1092-1 DN 100 PN 40 flange	752 °F (400 °C)	419
General purpose, stainless steel wetside, EN 1092-1 DN 125 PN 40 flange	752 °F (400 °C)	433
General purpose, stainless steel wetside, EN 1092-1 DN 150 PN 40 flange	752 °F (400 °C)	434
General purpose, stainless steel wetside, EN 1092-1 DN 80 PN 63 flange	752 °F (400 °C)	488
General purpose, stainless steel wetside, EN 1092-1 DN 100 PN 63 flange	752 °F (400 °C)	435
General purpose, stainless steel wetside, EN 1092-1 DN 125 PN 63 flange	752 °F (400 °C)	436
General purpose, stainless steel wetside, EN 1092-1 DN 150 PN 63 flange	752 °F (400 °C)	437

Magnetic Horizontal Level Switches
 Model: Aluminium-bronze & Stainless steel

Switch Mechanism ⁽⁶⁾

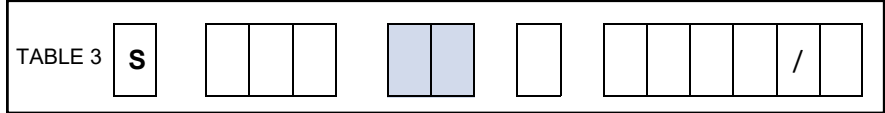

Description	Max T Process ⁽²⁾	Code
Electrical: 2 independent Single Pole Single Throw (SPST) contact sets	752 °F (400 °C)	D
As type D but with gold plated contacts	752 °F (400 °C)	P
Electrical: 2 independent circuits of Double Pole Double Throw (DPDT) contact sets	752 °F (400 °C)	D6
As type D6 but with gold plated contacts	752 °F (400 °C)	P6
As type D6 but with gold plated contacts and hermetically sealed moving parts	482 °F (250 °C)	H6
As type H6 but approved for Zone 2 areas	482 °F (250 °C)	B6
Pneumatic: air pilot valve on/off for switching air circuits	752 °F (400 °C)	AP
Pneumatic: air pilot valve for continuous modulating of air controlled circuits	752 °F (400 °C)	AM⁽⁷⁾

Switch Enclosure

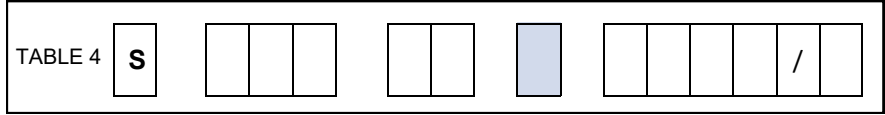

Description	Switch Type	Code
Aluminium alloy	All	A
Aluminium bronze (S01 switch head)	Not H6, B6, AP or AM	B

Magnetic Horizontal Level Switches
 Model: Aluminium-bronze & Stainless steel

Float (All ratings at T room) ⁽⁸⁾

TABLE 5	S								/
---------	---	--	--	--	--	--	--	--	---

Description	Switch types	Code
General purpose high/low alarm, 316 SST, min. SG 0.65, 500 psi (34.5 bar)	All	F84
Horizontal variable differential for pump control/alarm, 316 SST, min. SG 0.72, 500 psi (34.5 bar)	All except AM	F68/1⁽⁹⁾
Horizontal variable differential for pump control/alarm, 316 SST, min. SG 0.85, 500 psi (34.5 bar)	All except AM	F68/4⁽⁹⁾
Vertical pump control or alarm, 316 SST, rod length 1524mm, 435 psi (30 bar)	All except AM	F21/1⁽⁹⁾
Vertical pump control or alarm, 316 SST, rod length 3048mm, 435 psi (30 bar)	All except AM	F21/2⁽⁹⁾
Vertical pump control or alarm, 316 SST, rod length 4570mm, 435 psi (30 bar)	All except AM	F21/3⁽⁹⁾
Straight aim, 316 SST, rod length 750mm, 500 psi (34.5 bar)	All	F104/1⁽⁹⁾
Cranked arm, horizontal, 316 SST, dimensions to be specified, 500 psi (34.5 bar)	All	F104/2⁽⁹⁾
Cranked arm, vertical, 316 SST, dimensions to be specified, 500 psi (34.5 bar)	All	F104/3⁽⁹⁾
Shrouded for dirty liquids, 316 SST, min. SG 0.75, atmospheric	All	F93^{(5),(10)}
General purpose high/low alarm, Alloy 400, min. SG 0.65, 500 psi (34.5 bar)	All	F185
General purpose high/low alarm, 316 SST, min. SG 0.60, 1073 psi (74 bar)	All	F96
General purpose high/low alarm, 316 SST, min. SG 0.45, 500 psi (34.5 bar)	All	F98
General purpose high/low alarm, 316 SST, min. SG 0.51, 1073 psi (74 bar)	All	F106
General purpose high/low alarm, 316 SST, min. SG 0.71, 2900 psi (200 bar)	All	F107
Interface duties, 3166 SST, min. SG 0.80, 1073 psi (74 bar)	All	F88
Horizontal limited differential, Alloy 400, min. SG 0.85, 464 psi (32 bar)	All except AM	F264

1. See table 10 for nozzle and stud lengths.
2. The maximum allowed process temperature is dependent on Flange (Head), Switch mechanism, and Float options chosen.
3. There is no back flange fitted to the S36 and S190 flange (head).
4. See page 9 for Mobrey flange information.
5. The S190 flange (head) can only be used with the F93 float.
6. See "Switch mechanism specifications" on page 8 for information about all switch mechanisms.
7. Switch mechanism type AM is not compatible with float types F68/+, F21/+ or F264.
8. See Table 9 for a comparison of the float options listed here.
9. See pages 13, 14, 15 and 16 for technical float details and length options.
10. A silicone rubber gaiter is supplied with the 316 SST shroud.

Approvals

EUROPEAN DIRECTIVES



Low voltage Directive (LVD) 2014/35/EU.

Compliant to LVD

Pressure Equipment Directive (PED) 2014/68/EU:

This product is outside the scope of the PED directive

ATEX Directive 2014/34/EU

Hermetically sealed switch insert B6

EN 60079-0, EN 60079-15

For Zone 2

II 3 G Ex nC IIC T6...T2 Gc ($-60^{\circ}\text{C} \leq T_{amb} \leq +60^{\circ}\text{C}$)

GLOBAL CERTIFICATION

Canadian Standards Association

C22.2 NO 14

CSA Enc 4

MARINE

Lloyd's Register

Certificate no. 88/00224 (S01)

Certificate no. 88/0025 (S36, S190, S4**)

LR Test Specification No. 1

ENV1, ENV2

Russian Maritime Register of Shipping

Certificate no. 19.00211.278

RS Rules for classification and construction of sea-going ships.

Bureau Veritas

Certificate no. 04795/F1 BV (S01)

BV Rules for the classification of steel ships

American Bureau of Shipping

Certificate no. 19-GD1906187-1

IACS UR E10

DNV

Certificate no. TAA00002GZ (S01)

Certificate no. TAA00002H0 (S36, S190, S4**)

DNV GL rules for classification –Ships, offshore units, and high speed and light craft

Location classes: Temperature – A; Humidity – B; Vibration – B (Switch D, P) – A (switch D6, P6, H6);

Enclosure – C (S36, S190, S4**) – B (S01)

RINA





Certificate no. ELE270819CS001 (S01)

Rules for the classification of ships

Switch Characteristics

Table 6 Float Switch Specification – Aluminium bronze wetside - General Application	
Electric models	
Enclosure & wetside	Aluminium Bronze to BS 1400 – AB1 maximum iron content 2.5%
IP rating	Weatherproof to IEC 60529 (IP66)
End Cap	Short (4 contacts) e.g. S01DB, Aluminium to BS 1490 – grade LM24
	Long (6 contacts) e.g. S01D6B, Brass to BS 1400 – DCB3
Maximum Process Temperature	410°F (210°C) if shrouded float F93 used, maximum 356°F (180°C)
Gasket Material	Non-asbestos sheet material gaskets to BS 7531 Grade X, which has upper temperature limits of 482°F (250°C) for Gas, vapor and Steam and 824°F (440°C) for liquids
Dimensions	See page 9
Air pilot valve models	
Enclosure	Aluminium Alloy to BS 1490 Grade LM24
Valve Block	Aluminium Alloy to BS 1490 Grade LM24
Finish	All external aluminium surfaces are chromate phosphate treated and then externally painted
Maximum Process Temperature	410°F (210°C) if shrouded float F93 used, maximum 356°F (180°C)
Gasket Material	Non-asbestos sheet material gaskets to BS 7531 Grade X, which has upper temperature limits of 482°F (250°C) for Gas, vapor and Steam and 824°F (440°C) for liquids
Dimensions	See page 9
Table 7 Float Switch Specification – Stainless Steel wetside - General Application	
Electric models	
Enclosure / Housing material	Aluminium Alloy to BS 1490 Grade LM24
IP rating	Weatherproof to IEC 60529 (IP66)
Wetside material	316 Stainless Steel (to Mobrey std.)
	316S33 Stainless Steel for S489 and S490 switch types
Back Flange	Carbon Steel to BS 1501 : 224 grade 430B LT50
	This material has guaranteed properties at high 752°F (400°C) and low -58°F (-50°C) temperatures
Cable Gland	Nickel-plated brass gland with a fully insulated polychloroprene-nitrile rubber CR/NBR gasket seals. Clamping range from 8 to 13 mm OD cable
	Maximum ambient temperature is 176°F (80°C)
Maximum Process Temperature	Dependent upon Flange (head), switch mechanism and float option chosen. Note: See gasket materials below for gasket temperature limits
Gasket Material	Float switches with ASME B16.5 class 600, 900 or EN1062-1 PN63 flanges are fitted with spiral non-asbestos filled gaskets rated 752°F (400°C)
	Otherwise non-asbestos sheet material gaskets to BS 7531 Grade X, which has upper temperature limits of 482°F (250°C) for gas, vapor and Steam and 824°F (440°C) for liquids. For higher gas, vapor or Steam temperatures a suitable gasket must be used
Dimensions	See page 10
Air pilot valve models	
Enclosure	Aluminium Alloy to BS 1490 Grade LM24
Valve Block	Aluminium Alloy to BS 1490 Grade LM24
Finish	All external aluminium surfaces are chromate phosphate treated and then externally painted
Maximum Process Temperature	Dependent upon Flange (head), switch mechanism and float option chosen. Note: See gasket materials below for gasket temperature limits.
Connections	Brass compression couplings to suit 0.24" (6mm) copper or nylon pipe (coupling ¼" BSP)
Gasket Material	Float switches with ASME B16.5 class 600, 900 or EN1062-1 PN63 flanges are fitted with spiral non-asbestos filled gaskets rated 752°F (400°C)
	Otherwise non-asbestos sheet material gaskets to BS 7531 Grade X, which has upper temperature limits of 482°F (250°C) for gas, vapor and Steam and 824°F (440°C) for liquids. For higher gas, vapor or Steam temperatures a suitable gasket must be used
Dimensions	See page 10

Electric Characteristics

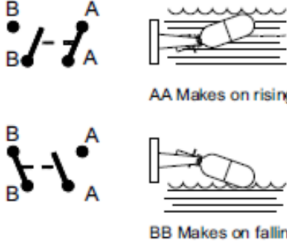
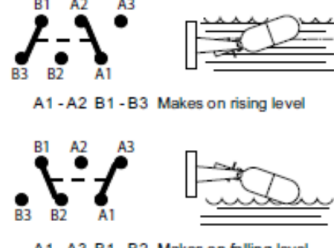
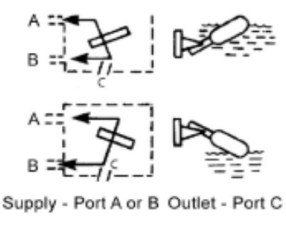
Table 8 Electrical switch mechanism specification			
Electrical type D and P	Electrical type D6 and P6	Electrical type H6 and B6	Pneumatic type AP and AM
			
Electrical switch mechanism		Pneumatic switch mechanism	
Type D <ul style="list-style-type: none"> For alternative make and break circuits Function: 2 independent Single Pole Single Throw contacts sets and "snap-action" May be wired S.P.C.O. on site 		Type AP <ul style="list-style-type: none"> For switching air circuits Function change-over Air pressure (air must be clean and dry): Maximum air pressure through valve : 100 psi (7 bar) Maximum air flow through valve : 66 l/m at 100psi (7bar) Nominal leakage rate of 0.2% Connections : brass compression couplings to suit 0.24in (6mm) copper or nylon pipe, coupling thread 1/4" BSP 	
Type D6 <ul style="list-style-type: none"> For switching two independent circuits Function Double Pole change over (2 independent circuits) and "snap-action" 		Type AM <ul style="list-style-type: none"> For modulating air controlled circuits Function continuous modulation Air pressure (air must be clean and dry): Maximum air pressure through valve : 20 psi (1.4 bar) Modulation linear 0 to 20 psi (0 to 1.4 bar). 2.9 psi to 20 psi (0.2 to 1.4 Bar) available on request. Temperature Medium 34 to 752°F (1 to 400 °C) Ambient 34 to 140 °F (1 to 60 °C) Lower ambient temperature can be tolerated if the air supply is 100% dry 	
Type P and P6 <ul style="list-style-type: none"> As type D and D6 but with Gold Plated Contacts for switching low power (e.g. Intrinsically Safe) electrical circuits 			
Type H6 <ul style="list-style-type: none"> For use in corrosive area and/or low temperature applications As type D6 but with Gold Plated Contacts and housed in an Inert Gas filled, Hermetically sealed enclosure 			
Type B6 <ul style="list-style-type: none"> For use in Zone 2 Hazardous Area As type H6 but coded ATEX II 3G, EExnC IIC T6 -76° F (-60°C) <Ta<140°F (60°C) 			
<div style="display: flex; justify-content: space-around;"> <div style="text-align: center;"> <p>Types D and P</p>  <p>AA Makes on rising level</p> <p>BB Makes on falling level</p> </div> <div style="text-align: center;"> <p>Types D6, P6, H6, and B6</p>  <p>A1 - A2 B1 - B3 Makes on rising level</p> <p>A1 - A3 B1 - B2 Makes on falling level</p> </div> <div style="text-align: center;"> <p>Type AP and AM</p>  <p>Supply - Port A or B Outlet - Port C</p> </div> </div>			
Electrical switch mechanism specification			
Electrical switch specification	D and D6	P and P6	H6 and B6
Contact Material	Fine Silver	Gold Plated	Gold plated
Process Temperature	-22 to 752°F (-30 to 400°C)	-22 to 752°F (-30 to 400°C)	-148 to 482°F (-100 to 250°C)
Ambient Temperature	-22 to 158°F (-30 to 70°C)	-22 to 158°F (-30 to 70°C)	-76 to 158°F (-60 to 70°C)
Insulation Valve	(Live to earth) > 100MΩ		
Terminals	D and P : M4 screws with non-rotating clamp plates		
	D6 and P6 : 6 way terminal block with pressure plates		
Electrical specification	AC	DC inductive	DC resistive
Maximum Voltage V	440	240	240
Maximum Current A	5.0 ⁽¹⁾	1.0	2.0
Maximum Power	2000 VA	35 Watts	70 Watts
	Power factor 0.4 maximum	Time constant 40ms maximum	
1. Maximum Current for "D" is 8A up to 410°F (210°C)			
WARNING			
The plating of gold contacts may be permanently damaged when used to switch circuits above the following limits : 300V 12mA resistive – 24V 2mH/200mA inductive – 24V 250mA resistive – 24V 750mH/10mA inductive			
NOTE: LVD (Low Voltage Directive) applied : EN60947 Parts 1 and 5.1			

Magnetic Horizontal Level Switches
Model: Aluminium-bronze & Stainless steel

Dimensions

Mobrey 'A' flange

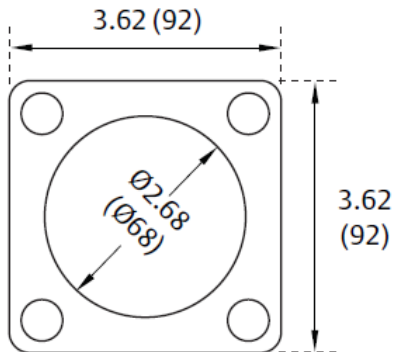

Mobrey 'A' flange:
4 off Ø0.55 (Ø14) holes equi-spaced on 3.62 (92) PCD

Note: Dimensions are in inches (mm).

General purpose float switches (aluminium bronze wetside)

Switch mechanism type DB and PB

Note: See Table 9 for dimensions X, Y and Z.

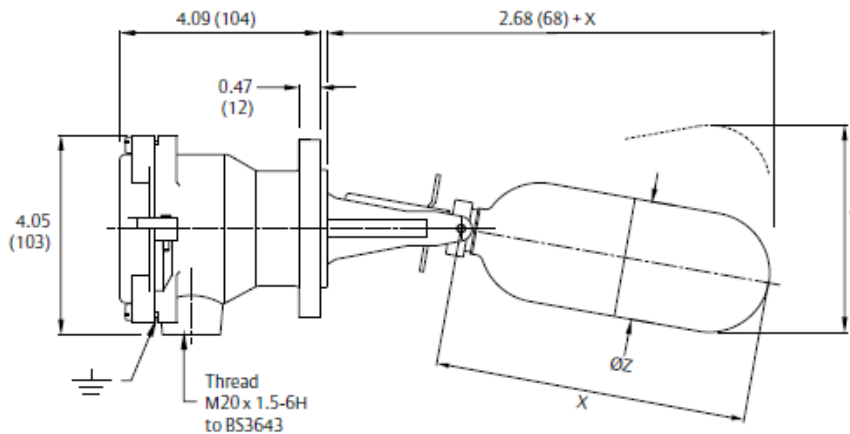

Switch mechanism type D6B and P6B

Note: See Table 9 for dimensions X, Y and Z.

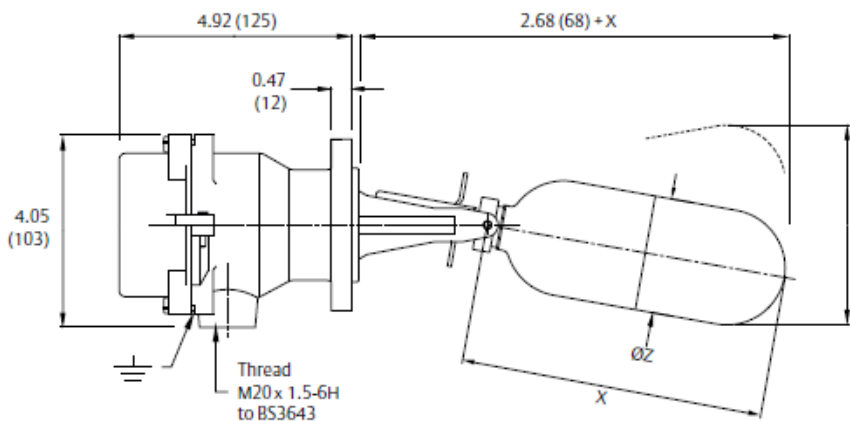

Note: Dimensions are in inches (mm).

Magnetic Horizontal Level Switches
Model: Aluminium-bronze & Stainless steel

General purpose float switches (stainless steel wetside)

Note: Dimensions are in inches (mm).

Note: See Table 9 for dimensions X, Y and Z.

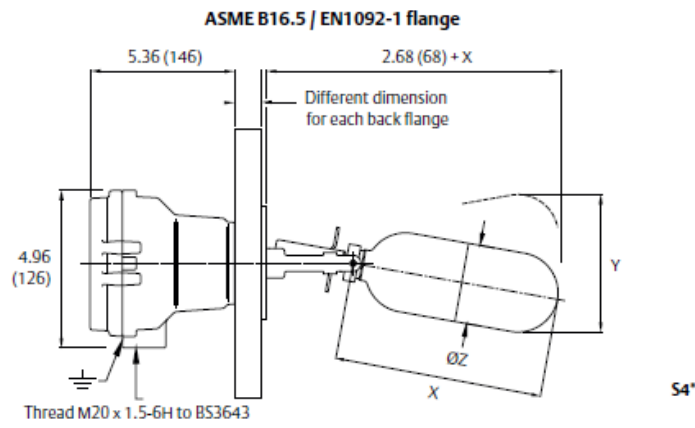
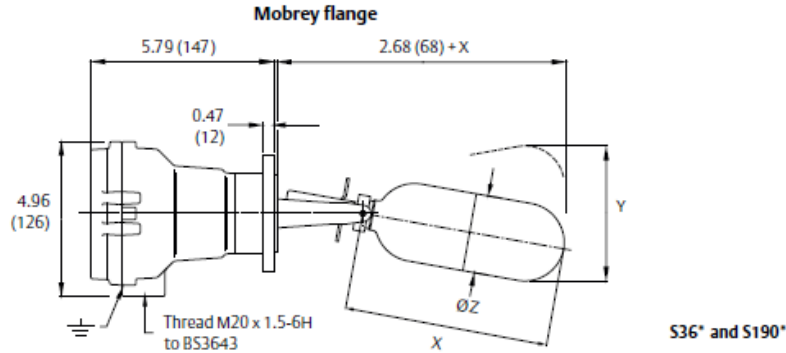

Table 9. Float dimensions X, Y, and Z – general purpose float switches

Float Type	Minimum S.G.	Max. P@T Room PSI (Bar)	Max. T Process °F (°C)	Differential in. (mm)	Dimension X in. (mm)	Dimension Y in. (mm)	Dimension ØZ in. (mm)	Float Material
F84	0.65	500 (34.5)	752 (400)	0.51 (13)	6.45 (164)	4.68 (119)	2.56 (65)	316 SST
F96	0.60	1073 (74)	752 (400)	0.51 (13)	6.45 (164)	4.68 (119)	2.56 (65)	316 SST
F98	0.45	500 (34.5)	752 (400)	0.55 (14)	7.24 (184)	5.00 (127)	2.56 (65)	316 SST
F106	0.51	1073 (74)	752 (400)	0.51 (13)	7.28 (185)	4.25 (108)	2.56 (65)	316 SST
F107	0.71	2900 (200)	752 (400)	0.51 (13)	6.77 (172)	4.72 (120)	2.46 (62.5)	316 SST
F68/ ⁽¹⁾	0.72 to 0.85	500 (34.5)	752 (400)	Variable (See page 13)			2.56 (65)	316 SST
F21/ ⁽¹⁾	0.70	435 (30)	752 (400)	Variable (See page 14)			5.08 (129)	316 SST
F104/ ⁽¹⁾	Various	500 (34.5)	752 (400)	As Ordered (See page 15)			2.56 (65)	316 SST
F88	0.8/1.0	1073 (74)	752 (400)	1.02 (26)	14.13 (359)	7.79 (198)	2.56 (65)	316 SST
F93	0.75	Atmospheric	356 (180)	0.51 (13)	7.20 (183)	4.88 (124)	2.56 (65)	316 SST
F185	0.67	500 (34.5)	752 (400)	0.51 (13)	6.45 (164)	4.68 (119)	2.56 (65)	Alloy 400
F264	0.85	464 (32.0)	752 (400)	0.9 (23)/1.14 (29)/1.3 (33)	7.05 (179)	Variable	2.56 (65)	Alloy 400

1. Refer to pages 13,14, 15 and 16 for technical float details and length options. See “Nozzle and stud lengths” on page 11 for stud lengths.

Magnetic Horizontal Level Switches
Model: Aluminium-bronze & Stainless steel

Nozzle and stud lengths

Table 10. Maximum Length in mm (Dimensions L)

	F68/*	F84	F185	F88	F93	F96	F98	F107	F106	F264
Mobrey A	65	75	75	135	75	75	90	-	92	75
DN65	65	75	75	135	-	75	90	-	92	75
DN80	70	80	80	170	-	75	90	-	98	90
DN100	95	105	105	200	-	105	105	-	110	100
DN125	105	140	140	200	-	140	140	-	140	140
DN150	224	180	180	200	-	180	170	-	200	190
3 in. 300/150	70	80	80	170	-	80	90	-	98	90
4 in. 300/150	95	105	105	200	-	105	105	-	110	100
3 in. 600	62	70	70	130	-	70	85	80	89	70
3 in. 900	-	-	-	-	-	70	-	80	-	-
Mobrey A	65	75	75	135	-	75	90	-	92	75
6 in. 150	224	180	180	200	-	180	170	-	200	190

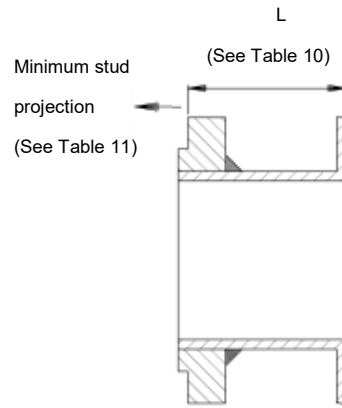
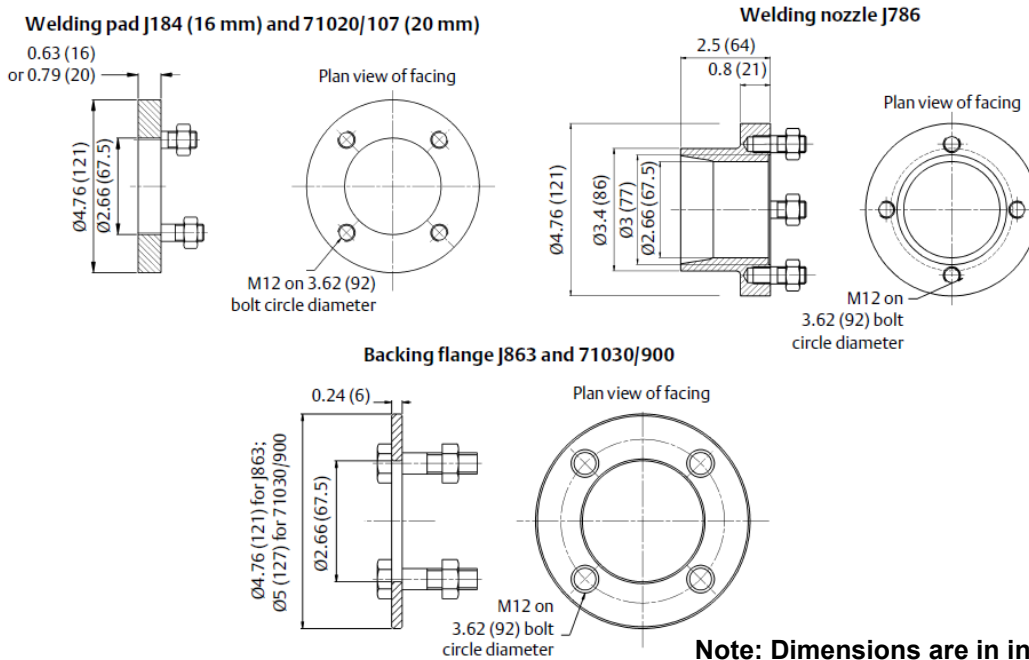

Table 11. Minimum stud projection (in mm)

Rating	G	A	PN 16					PN 40					PN 63				150		300		600	900
Size	-	-	65	80	100	125	150	65	80	100	125	150	80	100	125	150	3 in.	4 in.	3 in.	4 in.	3 in.	3 in.
Stud	35	30	40	40	40	40	44	42	42	46	52	54	52	55	62	67	46	56	54	56	64	73

Companion Flanges

Figure 1. Companion Flanges Mobrey 'A' Flanged Switches



Note: Dimensions are in inches (mm).

Magnetic Horizontal Level Switches
Model: Aluminium-bronze & Stainless steel

Pressure/Temperature Relationships

The graphs below show the maximum allowable working pressure of our float assemblies and process connection flanges across their working temperature range.

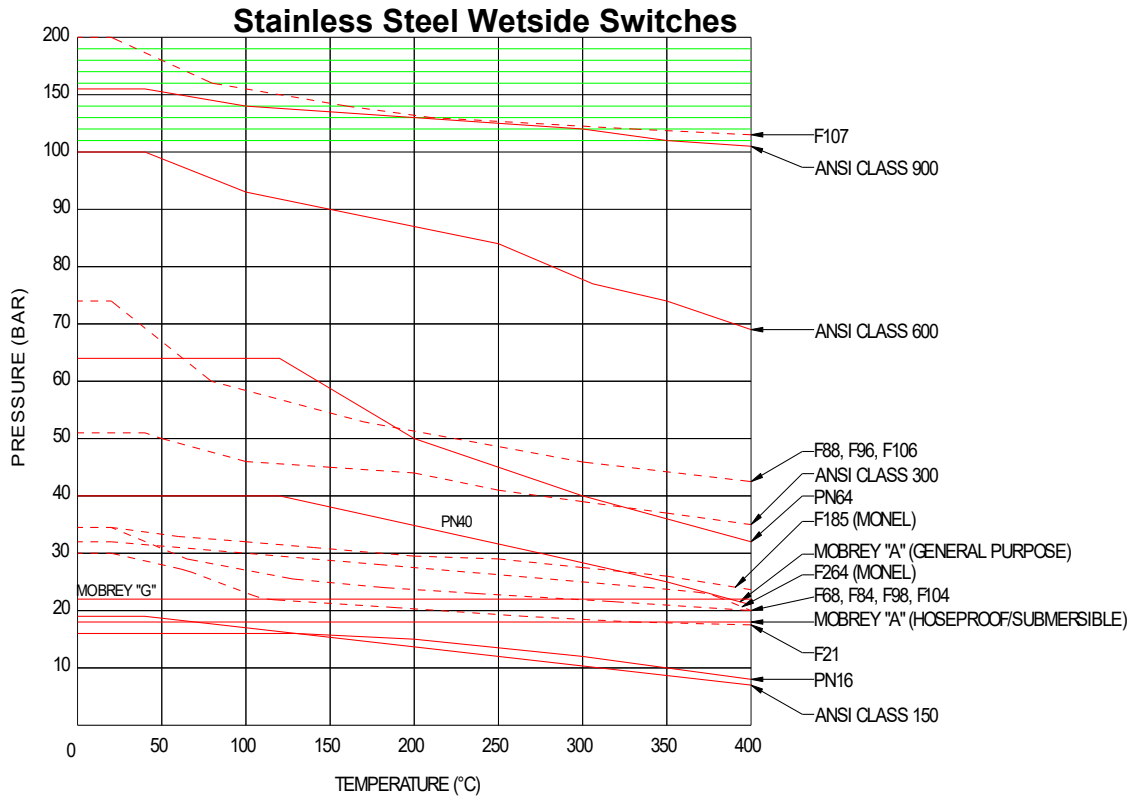

F93 WORKING PRESSURE: LIMITED TO ATMOSPHERIC UP TO 180°C

Non-Ferrous Wetside Switches

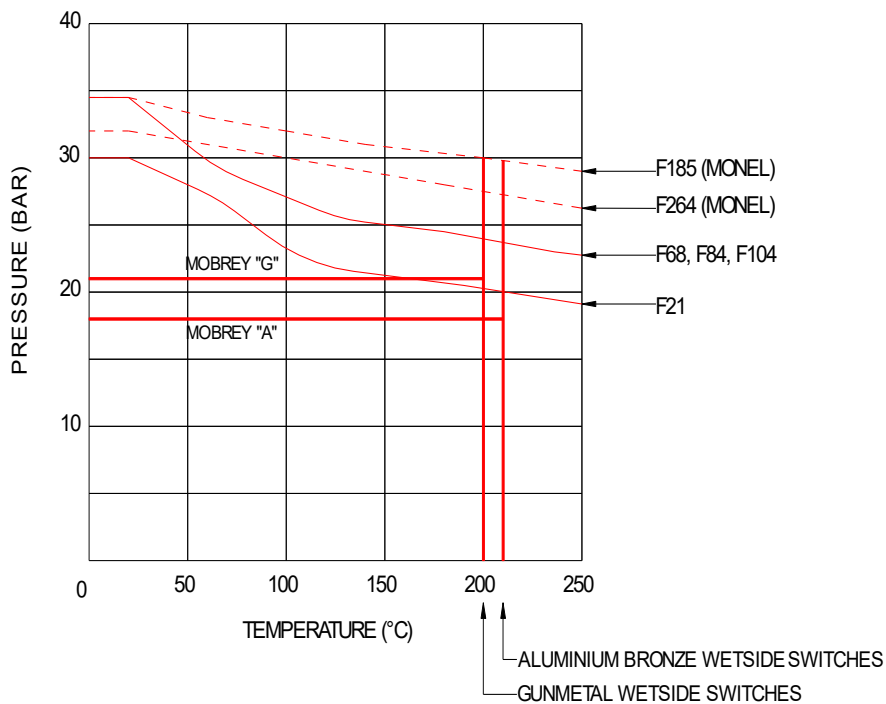

F93 WORKING PRESSURE: LIMITED TO ATMOSPHERIC UP TO 180°C

Magnetic Horizontal Level Switches
Model: Aluminium-bronze & Stainless steel

Horizontal F68 pump control and alarm float

Note: Dimensions are in inches (mm).

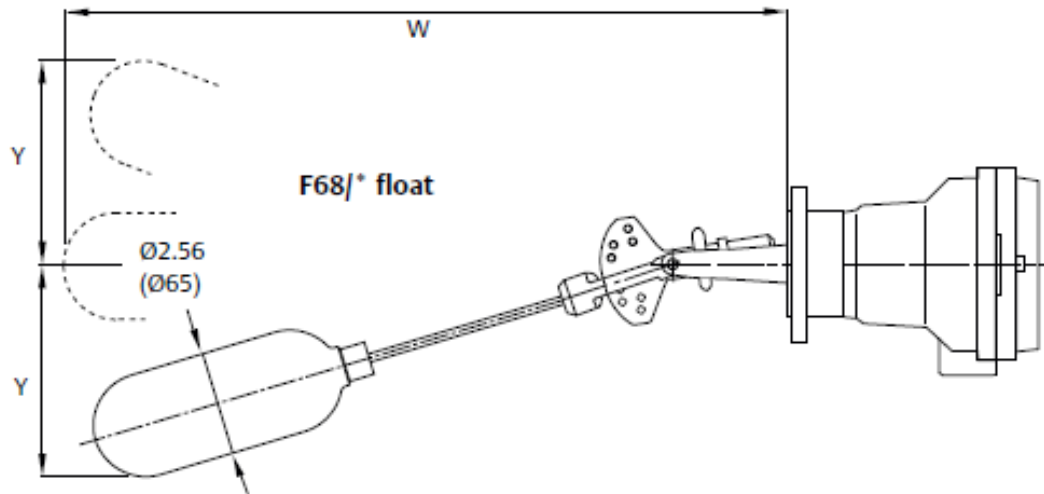
**Note**

Switches fitted with the F68/+ type float may be adjusted on site to meet pump control differentials. The float is available as F68/1 or F68/4. The F68/4 has pre-drilled holes along the rod to allow the user to achieve the /2 and /3 differentials in Table 12. Full details of the operating levels and differentials are in the product manual (Document Number M310).

Table 12. Dimensions and specifications for F68/*

Maximum Intrusions ⁽¹⁾	F68/1	F68/2	F68/3	F68/4
Wetside in. (mm) 'W'	14.2 (360)	18.5 (470)	23.2 (590)	25.3 (643)
Minimum tank dimension above/ below centre line (mm) 'Y'	8.5 (216)	11.5 (292)	14.5 (368)	16.0 (406)
Minimum Specific Gravity (S.G.)	0.72	0.8	0.82	0.85
Maximum differential (mm)	9.72 (247)	14.2 (360)	19.0 (483)	21.9 (555)

1. These dimensions in inches (mm) are approximate for cold water and will vary for liquids with a different specific gravity (SG.)

Vertical F21 pump control and alarm float

Note: See Table 13 for dimensions S and T.

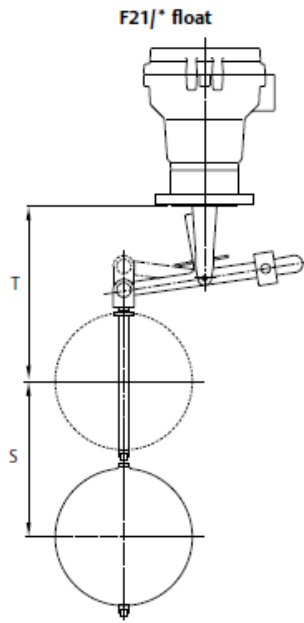

Note

Float assembly must be fitted from inside if for use in a vessel, or complete switch and float assembly may be mounted on a suitable bracket or manhole cover.

Float rod lengths available:

F21/1 5 ft. (1524 mm)

F21/2 10 ft. (3048 mm)

F21/3 15 ft. (4570 mm) maximum

Float rods may be cut to length on site and switches set to operate at required level in either pump control or alarm mode by following the supplied setting instructions.

Table 13. Dimensions S and T for F21/+

Pump differential 'S' in. (mm)	Alarm level in. (mm)	
	Minimum 'T'	Maximum 'S'
0.5 to 174.0 (13 to 4420) ⁽¹⁾	6.77 (172)	173.2 (4400) ⁽¹⁾

1. When the maximum rod length is specified.

Figure 2. Pump Control and Alarm Applications

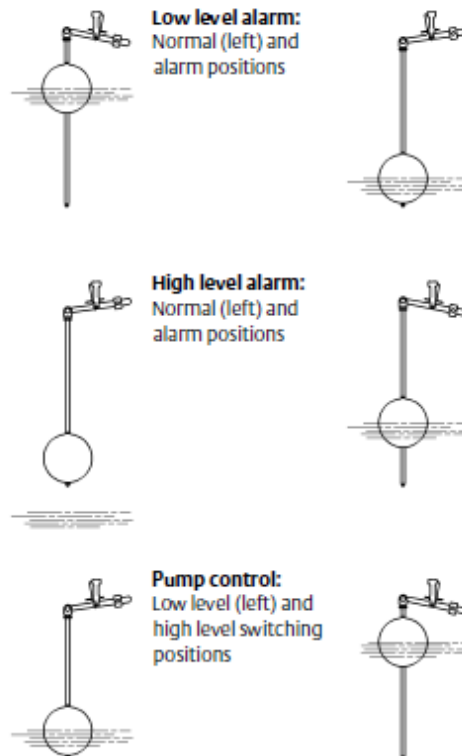

Cranked arm floats F104

Note: See Table 14 or Table 15 for dimensions in

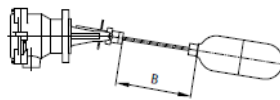
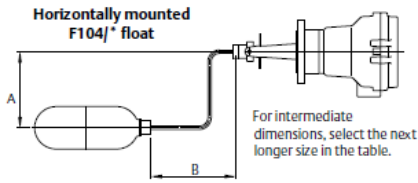

A plus B must not exceed 750 mm. A and B should each be equal to or greater than 75 mm, unless it is a straight arm where A is 0 mm (above).

To order, specify the F104 float with these details:

1. A and B (this page) or V and W (next page) dimensions. (For a straight arm float, state only the 'B' dimension).
2. Liquid in contact.
3. Specific Gravity (SG) of liquid.
4. Magnetic switch head type number (e.g. S01DB/F)
5. State land or marine application.

Table 14. Dimensions A and B with Minimum SG for Horizontally-mounted Switches (Land Applications)

		B																								
A		75	100	125	150	175	200	225	250	275	300	325	350	375	400	425	450	475	500	525	550	575	600	625	650	675
0 & 75		.64	.64	.65	.66	.67	.67	.68	.69	.70	.71	.72	.73	.73	.74	.75	.76	.77	.78	.79	.80	.81	.81	.82	.83	.84
100		.64	.65	.66	.67	.68	.69	.70	.70	.71	.72	.73	.74	.75	.76	.77	.78	.79	.79	.80	.81	.82	.83	.84	.85	
125		.65	.66	.67	.68	.69	.70	.71	.72	.73	.74	.75	.75	.76	.77	.78	.79	.80	.81	.82	.83	.84	.85	.86		
150		.65	.67	.68	.69	.70	.71	.72	.73	.74	.75	.76	.77	.78	.79	.80	.81	.82	.83	.84	.85	.85	.86			
175		.66	.67	.69	.70	.71	.72	.73	.74	.75	.76	.77	.78	.79	.80	.81	.82	.83	.84	.85	.86	.87				
200		.66	.68	.70	.71	.72	.73	.75	.76	.77	.78	.79	.80	.81	.82	.83	.84	.85	.86	.87	.88					
225		.67	.69	.70	.72	.73	.75	.76	.77	.78	.79	.80	.81	.82	.84	.85	.86	.87	.88	.89						
250		.67	.69	.71	.73	.74	.76	.77	.78	.80	.81	.82	.83	.84	.85	.86	.87	.88	.89							
275		.68	.70	.72	.74	.76	.77	.78	.80	.81	.82	.83	.85	.86	.87	.88	.89	.90								
300		.68	.71	.73	.75	.77	.78	.80	.81	.82	.84	.85	.86	.87	.88	.89	.90									
325		.69	.71	.74	.76	.78	.80	.81	.83	.84	.85	.86	.88	.89	.90	.91										
350		.69	.72	.75	.77	.79	.81	.82	.84	.85	.87	.88	.89	.90	.92											
375		.70	.72	.76	.78	.80	.82	.84	.85	.87	.88	.90	.91	.92												
400		.71	.73	.76	.79	.81	.83	.85	.87	.88	.90	.91	.92													
425		.71	.74	.77	.80	.83	.85	.87	.88	.90	.91	.93														
450		.72	.74	.78	.81	.84	.86	.88	.90	.91	.93															
475		.72	.75	.79	.82	.85	.87	.89	.91	.93																
500		.73	.76	.80	.83	.86	.89	.91	.93																	
525		.74	.77	.81	.85	.88	.90	.92																		
550		.74	.77	.81	.86	.89	.92																			
575		.75	.78	.82	.87	.90																				
600		.76	.79	.83	.88																					
625		.76	.80	.84																						
650		.77	.80																							
675		.78																								

Table 15. Dimensions A and B with Minimum SG for Horizontally-mounted Switches (Marine Applications)

		B																								
A		75	100	125	150	175	200	225	250	275	300	325	350	375	400	425	450	475	500	525	550	575	600	625	650	675
0 & 75		.67	.67	.68	.68	.69	.69	.70	.71	.72	.73	.73	.74	.75	.76	.77	.78	.79	.79	.80	.81	.82	.83	.84	.85	.86
100		.68	.68	.69	.70	.70	.71	.72	.73	.74	.74	.75	.76	.77	.78	.79	.80	.81	.81	.82	.83	.84	.85	.86	.87	
125		.69	.70	.71	.71	.72	.73	.74	.75	.76	.76	.78	.77	.79	.80	.81	.82	.83	.84	.84	.85	.86	.87	.88		
150		.71	.71	.72	.73	.74	.75	.76	.77	.78	.78	.79	.80	.81	.82	.83	.84	.85	.86	.87	.88	.89	.89			
175			.73	.74	.75	.76	.77	.78	.79	.80	.81	.82	.83	.83	.84	.85	.86	.87	.88	.89	.90	.91				
200				.76	.77	.78	.79	.80	.81	.82	.83	.84	.85	.86	.87	.88	.89	.90	.90	.91	.92					
225				.79	.80	.81	.82	.83	.84	.85	.86	.86	.87	.88	.89	.90	.91	.92	.93	.94						
250					.83	.84	.85	.86	.87	.87	.88	.89	.90	.91	.92	.93	.94	.95	.95							
275						.88	.88	.89	.90	.91	.91	.92	.93	.94	.95	.96	.96	.97								
300						.93	.93	.93	.93	.94	.95	.95	.96	.97	.98	.99	.99									
325							.98	.98	.98	.98	.98	.99	1.0	1.0	1.01	1.02										
350								1.04	1.03	1.02	1.03	1.03	1.03	1.04	1.04											
375									1.09	1.08	1.07	1.07	1.07	1.08												
400										1.15	1.13	1.12	1.12													
425											1.20	1.18														

Magnetic Horizontal Level Switches
Model: Aluminium-bronze & Stainless steel

Note: See Table 16 or Table 17 for dimensions in mm.

Vertically mounted
F104 float

For intermediate dimensions, select the next longer size in the table.

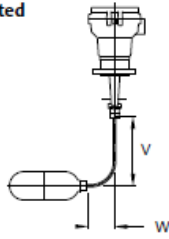

V plus W must not exceed 750 mm. V and W should each be equal to or greater than 75 mm.

Table 16. Dimensions V and W with Minimum SG for Vertically-mounted Switches (Land Applications)

		B																											
		75	100	125	150	175	200	225	250	275	300	325	350	375	400	425	450	475	500	525	550	575	600	625	650	675			
V																													
75		.67	.67	.66	.66	.66	.66	.67	.67	.68	.68	.68	.70	.70	.71	.72	.73	.73	.74	.75	.76	.77	.77	.78	.79	.80			
100		.67	.66	.66	.66	.66	.66	.67	.67	.68	.68	.69	.70	.70	.71	.72	.73	.73	.74	.75	.76	.77	.77	.78	.79				
125		.67	.66	.66	.66	.66	.66	.67	.67	.68	.68	.69	.70	.70	.71	.72	.73	.74	.74	.75	.76	.77	.78	.78					
150		.67	.66	.66	.66	.66	.66	.67	.67	.68	.68	.69	.70	.71	.71	.72	.73	.74	.74	.75	.76	.77	.78						
175		.67	.66	.66	.66	.66	.66	.67	.67	.68	.69	.69	.70	.71	.71	.72	.73	.74	.75	.75	.76	.77							
200		.67	.66	.66	.66	.66	.67	.67	.68	.68	.69	.69	.70	.71	.72	.72	.73	.74	.75	.75	.76								
225		.66	.66	.66	.66	.66	.67	.67	.68	.68	.69	.70	.70	.71	.72	.72	.73	.74	.75	.76									
250		.66	.66	.66	.66	.67	.67	.67	.68	.68	.69	.70	.70	.71	.72	.73	.73	.74	.75										
275		.67	.66	.66	.67	.67	.67	.68	.68	.69	.69	.70	.71	.71	.72	.73	.73	.74											
300		.67	.67	.66	.67	.67	.67	.68	.68	.69	.69	.70	.71	.71	.72	.73	.74												
325		.67	.67	.67	.67	.67	.67	.68	.68	.69	.70	.70	.71	.72	.72	.73													
350		.67	.67	.67	.67	.67	.68	.68	.69	.69	.70	.70	.71	.72	.72														
375		.68	.67	.67	.67	.67	.68	.68	.69	.69	.70	.71	.71	.72															
400		.68	.67	.67	.67	.68	.68	.68	.69	.70	.70	.71	.71																
425		.68	.68	.68	.68	.68	.68	.69	.69	.70	.70	.71																	
450		.68	.68	.68	.68	.68	.68	.69	.69	.70	.71																		
475		.69	.68	.68	.68	.69	.69	.69	.70	.70																			
500		.69	.69	.68	.68	.69	.69	.69	.70																				
525		.69	.69	.69	.69	.69	.69	.70																					
550		.70	.69	.69	.69	.69	.70																						
575		.70	.70	.69	.69	.70																							
600		.70	.70	.70	.70																								
625		.71	.70	.70																									
650		.71	.71																										
675		.72																											

Table 17. Dimensions V and W with Minimum SG for Vertically-mounted Switches (Marine Applications)

		W																											
		75	100	125	150	175	200	225	250	275	300	325	350	375	400	425	450	475	500	525	550	575	600	625	650	675			
V																													
75		.75	.72	.70	.69	.68	.68	.68	.68	.68	.69	.70	.71	.71	.72	.73	.74	.74	.75	.76	.77	.78	.79	.79	.80	.81			
100		.76	.72	.70	.68	.67	.68	.68	.68	.69	.70	.70	.71	.72	.73	.73	.74	.75	.76	.77	.77	.78	.79	.80	.81				
125		.77	.72	.69	.67	.67	.68	.68	.69	.69	.70	.71	.72	.72	.73	.74	.75	.75	.76	.77	.78	.79	.80	.80					
150		.79	.72	.68	.67	.67	.68	.69	.69	.70	.71	.71	.72	.73	.74	.74	.75	.76	.77	.78	.78	.79	.80						
175			.71	.67	.67	.68	.68	.69	.70	.70	.71	.72	.73	.73	.74	.75	.76	.76	.77	.78	.79	.79							
200				.67	.68	.68	.69	.70	.70	.71	.72	.72	.73	.74	.75	.75	.76	.77	.78	.79	.79								
225					.68	.69	.70	.70	.71	.72	.72	.73	.74	.74	.75	.76	.77	.77	.78	.78									
250					.69	.70	.70	.71	.71	.72	.73	.74	.74	.75	.76	.77	.77	.78	.78										
275						.70	.71	.71	.72	.73	.73	.74	.75	.76	.76	.77	.78	.79											
300							.71	.73	.73	.74	.75	.76	.76	.77	.78	.79													
325								.73	.73	.74	.75	.75	.76	.77	.78	.78													
350									.74	.75	.75	.76	.77	.78	.78														
375										.75	.76	.77	.77	.78															
400											.77	.77	.78																
425												.78																	

Magnetic Horizontal Level Switches
Model: Aluminium-bronze & Stainless steel

Ordering Accessories

Table 18. Ordering Information for Accessories

Accessories	Note: See page 9 for dimensions of Mobrey flanges
TD 110/A	316 stainless steel test device for Mobrey 'A' flanged switches, sandwich (see below) *
TD 111/A	Carbon steel test device for Mobrey 'A' flanged switches, weld on (see below) *
71020/107	316 stainless steel welding pad for Mobrey 'A' flanged switches (see page 11)
J184	Carbon steel welding pad for Mobrey 'A' flanged switches (see page 11)
J786	Carbon steel welding nozzle for Mobrey 'A' flanged switches (see page 11)
71030/900	316 stainless steel backing flange for Mobrey 'A' flanged switches (see page 11)
J863	Carbon steel backing flange for Mobrey 'A' flanged switches (see page 11)

Testing Device

Figure 3. Test Devices for Mobrey 'A' Flanged Switches

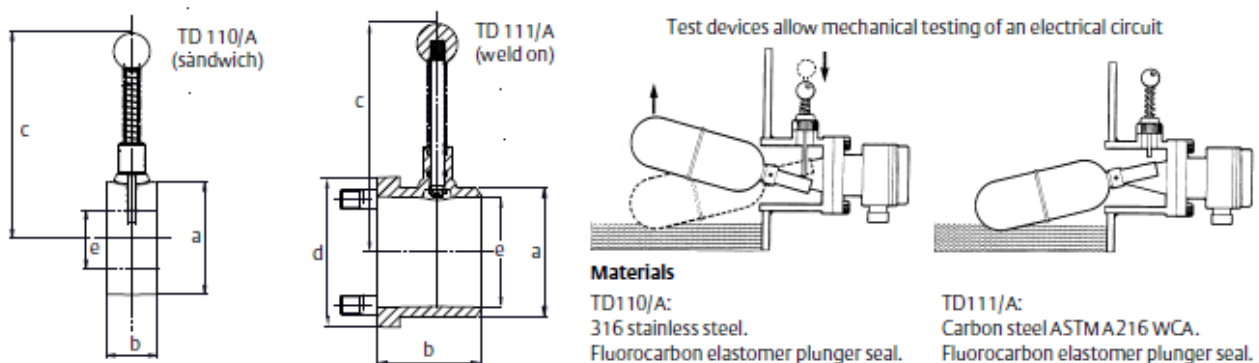

Table 19. Test Device Specifications and Dimensions

Type	Vessel flange	Maximum pressure ⁽¹⁾	Maximum T process	Øa in. (mm)	b in. (mm)	c in. (mm)	d in. (mm)	Øe in. (mm)
TD 110/A	Mobrey 'A'	261psi (18 bar)	410°F (210°C)	3.02 (77)	1.38 (35)	5.59 (142)	N/A	2.64 (67)
TD 111/A	Weld on	261 psi (18 bar)	410°F (210°C)	3.11 (79)	2.52 (64)	5.59 (142)	3.62 (92) ⁽²⁾	2.64 (67)

- 182 psi (12.6 bar) at maximum temperature of 410 °F (210 °C).
- See Mobrey 'A' flange dimension 3.62 x 3.62 in. (92 x 92 mm) on page 9.

Float chambers

Float chambers are used to facilitate the external mounting of the float switch onto a tank or pressure vessel, particularly where space inside the vessel is restricted or where the control must be isolated for routine maintenance whilst the plant is in operation. A wide range of cast or fabricated chambers is available. Exotic materials are also available. Process connections may be specified as top-and-bottom or side-and-side, and can be flanged, screwed or butt welded in a choice of sizes to suit most plant installations. Please contact Delta Mobrey for further information.



ISO9001

In the interest of development and improvement Delta Mobrey Ltd, reserves the right to amend, without notice, details contained in this publication. No legal liability will be accepted by Delta Mobrey Ltd for any errors, omissions or amendments.

Delta Mobrey Limited

Hudson House, Albany Park Camberley Surrey, GU16 7PL, UK.
 T+44 (0)1252 729140 F+44 (0)1252 729168 E sales@delta-mobrey.com W www.delta-mobrey.com



FM00720
Page 17 of 17