



Level



Pressure



Flow



Temperature

Liquid
Analysis

Registration

Systems
Components

Services



Solutions

Technical Information

Proline Promag 55S

Electromagnetic Flow Measuring System

Flow rate measurement of liquids with solids content or inhomogeneous liquids

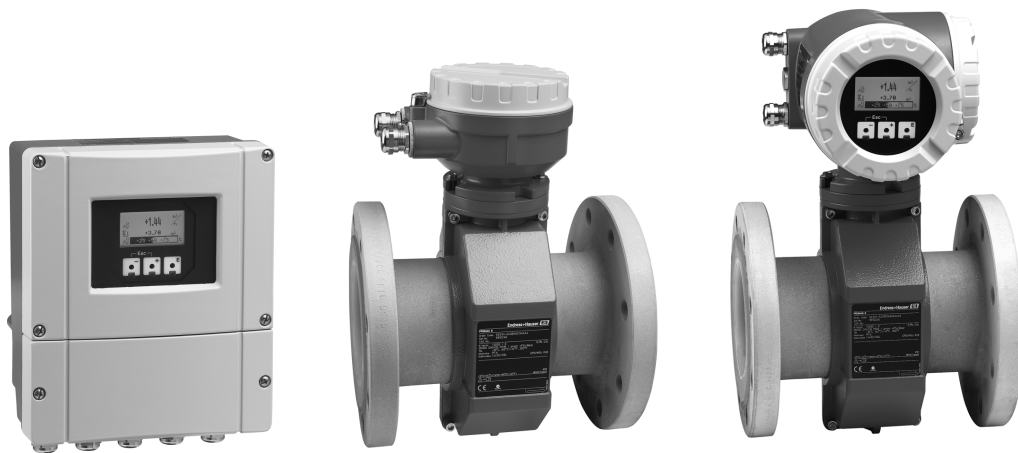

Application

Electromagnetic flowmeter for bidirectional measurement of liquids with a minimum conductivity of $\geq 5 \mu\text{S}/\text{cm}$ – in particular fluids with solids, and fluids which are abrasive, inhomogeneous or tend to build-up, for example:

- Chemical/mechanical pulps, paper pulp or wood pulp with solids contents up to 15 Vol.-%
- Fruit mashes, fruit concentrates and final products (salad dressings, soups with vegetable pieces)
- Slurries containing high amounts of sand or stone with an abrasive effect, e.g. ore slurry or mortar
- Chemically inhomogeneous fluids (e.g. additives)
- Thick wastewater sludges
- Flow measurement up to $9600 \text{ m}^3/\text{h}$ (42267 gal/min)
- Can be used up to $+180 \text{ }^\circ\text{C}$ ($+356 \text{ }^\circ\text{F}$) and max. 40 bar (580 psi)
- Fitting lengths as per DVGW/ISO

Application-specific linings and electrodes:

- Natural rubber, hard rubber, polyurethane, PTFE or PFA linings
- Flat, bullet nose, neck, bow or brush electrodes

Approvals for hazardous area:

- ATEX, FM, CSA

Connection to process control system:

- HART, PROFIBUS DP/PA, FOUNDATION Fieldbus

Your benefits

Promag measuring devices offer you cost-effective flow measurement with a high degree of accuracy for a wide range of process conditions.

The **Proline transmitter concept** comprises of:

- High degree of efficiency due to the modular device and operating concept
- Software options for: electrode cleaning, advanced diagnostics, calculation of mass flow and solids content

The robust **Promag S sensors** offer:

- Universal devices, even for difficult fluids
- Excellent accuracy and repeatability
- High resistance to abrasion thanks to industry-optimized linings and measuring electrodes
- Optimum operational safety due to advanced, permanent self-diagnosis
- Simple installation and commissioning
- Insensitive to vibration
- No pressure loss

Table of contents

Function and system design	3	Mechanical construction	29
Measuring principle	3	Design, dimensions	29
Measuring system	3	Weight	39
Input	4	Materials	41
Measured variable	4	Material load diagrams	41
Measuring range	4	Fitted electrodes	43
Operable flow range	4	Process connections	43
Input signal	4	Surface roughness	43
Output	4	Human interface	44
Output signal	4	Display elements	44
Signal on alarm	5	Operating elements	44
Load	5	Language groups	44
Low flow cut off	5	Language groups	44
Galvanic isolation	5	Certificates and approvals	45
Switching output	5	CE mark	45
Power supply	6	C-tick mark	45
Electrical connection measuring unit	6	Ex certification	45
Electrical connection terminal assignment	7	Sanitary compatibility	45
Electrical connection remote version	8	Pressure measuring device approval	45
Electrical connections	8	FOUNDATION Fieldbus certification	45
Cable entries	8	PROFIBUS DP/PA certification	45
Cable specifications (remote version)	9	Other standards, guidelines	45
Power consumption	9	Ordering information	46
Power supply failure	10	Accessories	46
Potential equalization	10	Supplementary documentation	46
Performance characteristics	13	Registered trademarks	46
Reference conditions	13		
Maximum measured error	13		
Repeatability	13		
Operating conditions: Installation	14		
Installation instructions	14		
Operating conditions: Environment	20		
Ambient temperature	20		
Storage temperature	20		
Degree of protection	20		
Shock and vibration resistance	20		
Electromagnetic compatibility (EMC)	20		
Operating conditions: Process	21		
Medium temperature range	21		
Conductivity	22		
Limiting medium pressure range (nominal pressure)	22		
Pressure tightness (lining)	22		
Nominal diameter and flow rate	24		
Pressure loss	25		
Measuring tube specifications	26		

Function and system design

Measuring principle

Faraday's law of induction states that a voltage is induced in a conductor moving in a magnetic field. In electromagnetic measuring, the flowing medium corresponds to the moving conductor. The induced voltage is proportional to the flow velocity and is detected by two measuring electrodes and transmitted to the amplifier. Flow volume is computed on the basis of the pipe's diameter. The constant magnetic field is generated by a switched direct current of alternating polarity.

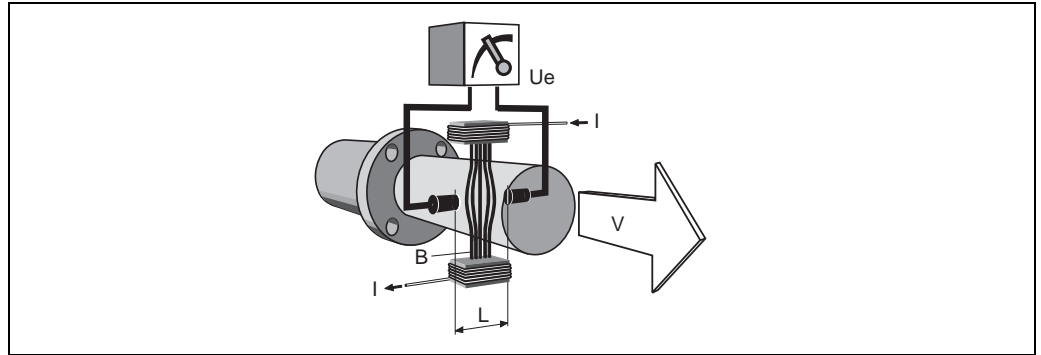

$$U_e = B \cdot L \cdot v$$

$$Q = A \cdot v$$

- U_e induced voltage
- B magnetic induction (magnetic field)
- L electrode gap
- v flow velocity
- Q volume flow
- A pipe cross-section
- I current strength

Measuring system

The flow measuring system consists of the following components:

- Promag 55 transmitter
- Promag S sensor (DN 15 to 600 / ½ to 24")

Two versions are available:

- Compact version: Transmitter and sensor form a single mechanical unit.
- Remote version: Transmitter and sensor are installed separately.

Measurement of solids flow rates

In combination with a density meter, e.g. with "Gammapilot M" from Endress+Hauser, Promag 55S also determines the throughput of solids in mass, volume or percentage rates.

The following order specifications are required for this: order option for software function "Solids content flow" (F-CHIP) and order option for a current input.

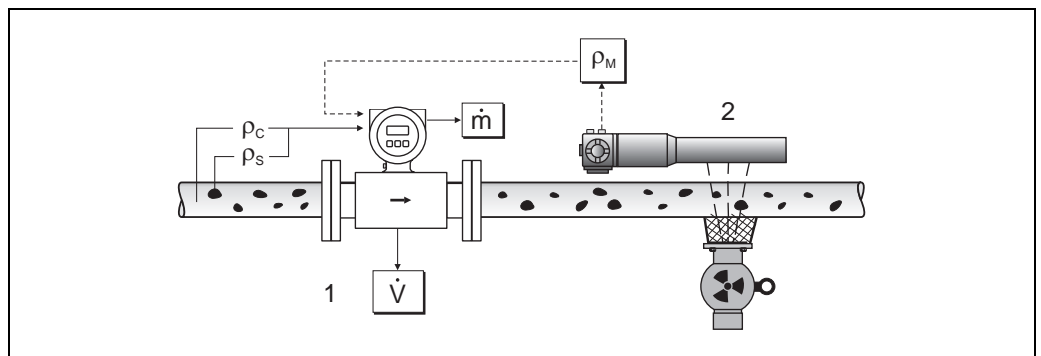

Solids content flow measurement (\dot{m}) with the aid of a density and flow measuring device. If the solid density (ρ_s) and the density of the carrier liquid (ρ_c) are also known, they can be used to calculate the solids flow.

- 1 Flow measuring device (Promag 55S) \rightarrow volume flow (\dot{V}). The solid density (ρ_s) and the density of the transport liquid (ρ_c) must be entered in the transmitter.
- 2 Density measuring device (e.g. "Gammapilot M") \rightarrow total fluid density (ρ_M) (transport liquid and solids)

Input

Measured variable	<ul style="list-style-type: none"> ■ Flow rate (proportional to induced voltage) ■ Conductivity (without temperature compensation)
Measuring range	<ul style="list-style-type: none"> ■ Flow rate: Typical $v = 0.01$ to 10 m/s (0.03 to 33 ft/s) with the specified measuring accuracy ■ Conductivity $s = 5$ to 2000 $\mu\text{S}/\text{cm}$ not for sensors without reference electrode (Promag S with brush electrodes)
Operable flow range	Over 1000 : 1
Input signal	<p>Status input (auxiliary input)</p> <p>$U = 3$ to 30 V DC, $R_i = 5$ kΩ, galvanically isolated Configurable for: totalizer(s) reset, positive zero return, error-message reset</p> <p>Status input (auxiliary input) with PROFIBUS DP</p> <p>$U = 3$ to 30 V DC, $R_i = 3$ kΩ, galvanically isolated. Switch level: $\pm 3 \dots \pm 30$ V DC, independent of polarity. Configurable for: positive zero return, error message reset, zero point adjustment start</p> <p>Current input</p> <p>active/passive selectable, galvanically isolated, full scale value adjustable, resolution: 3 μA, temperature coefficient: typically 0.005% o.f.s./$^{\circ}\text{C}$ (0.003% o.f.s./$^{\circ}\text{F}$)</p> <ul style="list-style-type: none"> ■ active: 4 to 20 mA, $R_i \leq 150$ Ω, $U_{\text{out}} = 24$ V DC, short-circuit proof ■ passive: 0/4 to 20 mA, $R_i \leq 150$ Ω, $U_{\text{max}} = 30$ V DC

Output

Output signal	<p>Current output</p> <p>active/passive selectable, galvanically isolated, time constant selectable (0.01 to 100 s), full scale value adjustable, temperature coefficient: typically 0.005% o.f.s./$^{\circ}\text{C}$ (0.003 % o.f.s./$^{\circ}\text{F}$), resolution: 0.5 μA</p> <ul style="list-style-type: none"> ■ active: 0/4 to 20 mA, $R_L < 700$ Ω (for HART: $R_L \geq 250$ Ω) ■ passive: 4 to 20 mA; supply voltage V_S: 18 to 30 V DC; $R_i \geq 150$ Ω <p>Pulse/frequency output</p> <p>active/passive selectable (Ex i version passive only), galvanically isolated</p> <ul style="list-style-type: none"> ■ active: 24 V DC, 25 mA (max. 250 mA over 20 ms), $R_L > 100$ Ω ■ passive: open collector, 30 V DC, 250 mA ■ Frequency output: end frequency 2 to 10000 Hz ($f_{\text{max}} = 12500$ Hz), on/off ratio 1:1, pulse width max. 10 s ■ Pulse output: pulse value and pulse polarity selectable, pulse width configurable (0.05 to 2000 ms) <p>PROFIBUS DP interface</p> <ul style="list-style-type: none"> ■ Transmission technology (Physical Layer): RS485 according to ANSI/TIA/EIA-485-A: 1998, galvanically isolated ■ Profile Version 3.0 ■ Data transmission rate: 9.6 kBaud to 12 MBaud ■ Automatic identification of data transmission rate ■ Function blocks: 2 \times analog input, 3 \times totalizer ■ Output data: volume flow, calculated mass flow, totalizer 1 to 3 ■ Input data: positive zero return (ON/OFF), totalizer control, value for local display ■ Cyclic data transmission compatible with previous model Promag 35S ■ Bus address adjustable via miniature switches or local display (optional) at the measuring device ■ Available output combination \rightarrow 7
----------------------	--

PROFIBUS PA interface

- Transmission technology (Physical Layer): IEC 61158-2 (MBP), galvanically isolated
- Profile version 3.0
- Current consumption: 11 mA
- Permissible supply voltage: 9 to 32 V
- Bus connection with integrated reverse polarity protection
- Error current FDE (Fault Disconnection Electronic): 0 mA
- Function blocks: 2 × analog input, 3 × totalizer
- Output data: volume flow, calculated mass flow, totalizer 1 to 3
- Input data: positive zero return (ON/OFF), totalizer control, value for local display
- Cyclic data transmission compatible with previous model Promag 35S
- Bus address adjustable via miniature switches or local display (optional) at the measuring device

FOUNDATION Fieldbus interface

- FOUNDATION Fieldbus H1
- Transmission technology (Physical Layer): IEC 61158-2 (MBP), galvanically isolated
- ITK version 5.01
- Current consumption: 12 mA
- Inrush current: < 12 mA
- Error current FDE (Fault Disconnection Electronic): 0 mA
- Permissible supply voltage: 9 to 32 V
- Bus connection with integrated reverse polarity protection
- Function blocks:
 - 5 × Analog Input (execution time: 18 ms each)
 - 1 × PID (25 ms)
 - 1 × Digital Output (18 ms)
 - 1 × Signal Characterizer (20 ms)
 - 1 × Input Selector (20 ms)
 - 1 × Arithmetic (20 ms)
 - 1 × Integrator (18 ms)
- Total VCRs: 48
- Total link objects in VFD: 40
- Output data: volume flow, calculated mass flow, temperature, totalizer 1 to 3
- Input data: positive zero return (ON/OFF), reset totalizer
- Link Master (LM) functionality is supported

Signal on alarm	<p>Current output</p> <p>Failsafe mode selectable (e.g. according to NAMUR recommendation NE 43)</p> <p>Pulse/frequency output</p> <p>Failsafe mode selectable</p> <p>Relay output</p> <p>"de-energized" in the event of a fault or power supply failure</p> <p>PROFIBUS DP/PA</p> <p>Status and alarm messages in accordance with PROFIBUS Profile Version 3.0</p>
Load	See "output signal"
Low flow cut off	Switch points for low flow freely selectable.
Galvanic isolation	All circuits for inputs, outputs, and power supply are galvanically isolated from each other.
Switching output	<p>Relay output</p> <p>Normally closed (NC or break) or normally open (NO or make) contacts available (default: relay 1 = NO, relay 2 = NC), max. 30 V / 0.5 A AC; 60 V / 0.1 A DC, galvanically isolated.</p> <p>Configurable for: error messages, empty pipe detection (EPD), direction of flow, limit values.</p>

Power supply

Electrical connection measuring unit

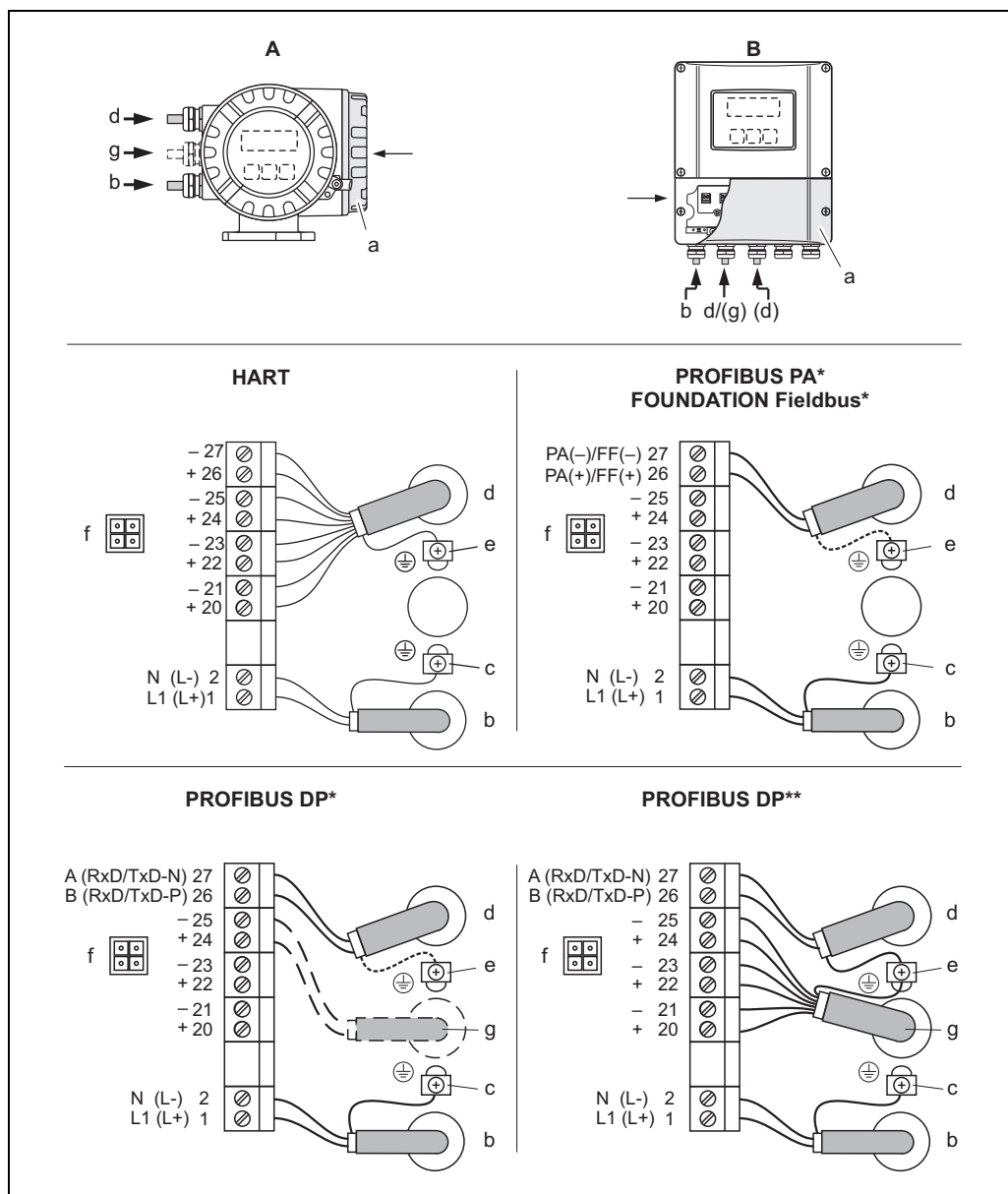

Connecting the transmitter, cable cross-section max. 2.5 mm² (14 AWG)

A View A (field housing)

B View B (wall-mount housing)

*) Fixed communication boards

**) Flexible communication boards

a Connection compartment cover

b Cable for power supply: 20 to 260 V AC / 20 to 64 V DC

- Terminal No. 1: L1 for AC, L+ for DC

- Terminal No. 2: N for AC, L- for DC

c Ground terminal for protective conductor

d Signal cable: see Terminal assignment → 7

Fieldbus cable:

- Terminal No. 26: DP (B) / PA (+) / FF (+): with polarity protection

- Terminal No. 27: DP (A) / PA (-) / FF (-): with polarity protection

e Ground terminal for signal cable shield / Fieldbus cable

f Service adapter for connecting service interface FXA193 (Fieldcheck, FieldCare)

g Signal cable: see Terminal assignment → 7

Cable for external termination (only for PROFIBUS DP with permanent assignment communication board):

- Terminal No. 24: +5 V

- Terminal No. 25: DGND

**Electrical connection
terminal assignment**

Order version	Terminal No. (inputs / outputs)			
	20 (+) / 21 (-)	22 (+) / 23 (-)	24 (+) / 25 (-)	26 (+) / 27 (-)
<i>Fixed communication boards (fixed assignment)</i>				
55***_*****A	–	–	Frequency output	Current output HART
55***_*****B	Relay output 2	Relay output 1	Frequency output	Current output HART
55***_*****H	–	–	–	PROFIBUS PA
55***_*****J	–	–	+5V (ext. termination)	PROFIBUS DP
55***_*****K	–	–	–	FOUNDATION Fieldbus
<i>Flexible communication boards</i>				
55***_*****C	Relay output 2	Relay output 1	Frequency output	Current output HART
55***_*****D	Status input	Relay output	Frequency output	Current output HART
55***_*****L	Status input	Relay output 2	Relay output 1	Current output HART
55***_*****M	Status input	Frequency output 2	Frequency output 1	Current output HART
55***_*****P	Current output	Frequency output	Status input	PROFIBUS DP
55***_*****V	Relay output 2	Relay output 1	Status input	PROFIBUS DP
55***_*****2	Relay output	Current output 2	Frequency output	Current output 1 HART
55***_*****3	Current input	Current output 2	Frequency output	Current output 1 HART
55***_*****4	Current input	Relay output	Frequency output	Current output HART
55***_*****5	Status input	Current input	Frequency output	Current output HART

Electrical connection remote version

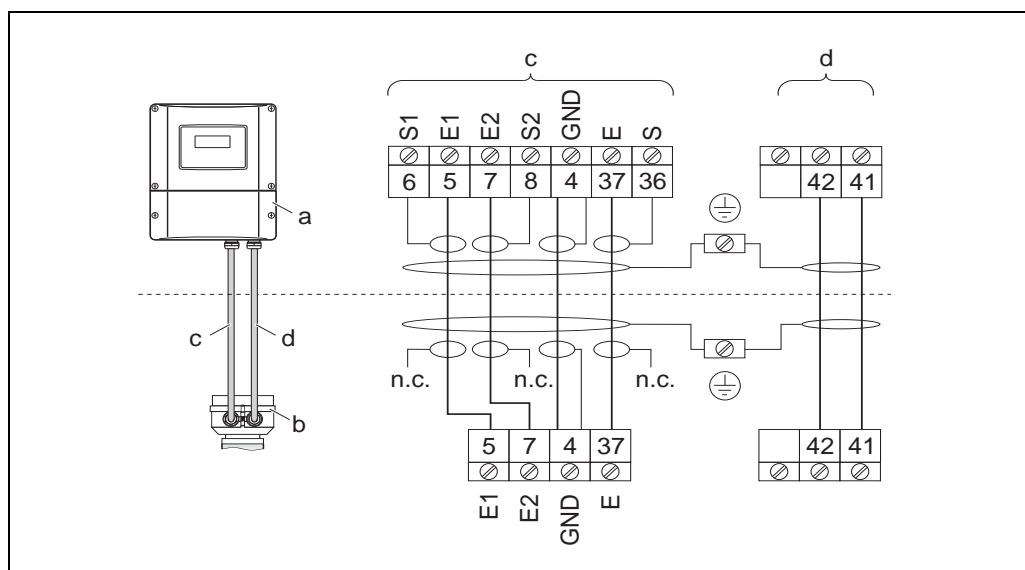

Connecting the remote version

a Connection compartment, wall-mount housing

b Cover of connection housing, sensor

c Signal cable

d Coil current cable

n.c. unconnected, insulated cable shields

Terminal no. and cable colors: 6/5 = brown; 7/8 = white; 4 = green; 36/37 = yellow

Electrical connections

20 to 260 V AC, 45 to 65 Hz
20 to 64 V DC

Cable entries

Power-supply and signal cables (inputs/outputs):

- Cable gland M20 × 1.5 (8 to 12 mm / 0.31 to 0.47")
- Cable entries for thread ½" NPT, G ½"

Fieldbus cable:

- Fieldbus connector for PROFIBUS PA, M12 × 1 / PG 13.5 plus adapter PG 13.5 / M20.5
- Fieldbus connector for FOUNDATION Fieldbus, 7/8-16 UNC × M20

Connecting cable for remote version:

- Cable gland M20 × 1.5 (8 to 12 mm / 0.31 to 0.47")
- Cable entries for thread ½" NPT, G ½"

**Cable specifications
(remote version)**

Coil cable

- $2 \times 0.75 \text{ mm}^2$ (18 AWG) PVC cable with common, braided copper shield ($\varnothing \sim 7 \text{ mm} / 0.28''$)
- Conductor resistance: $\leq 37 \text{ } \Omega/\text{km}$ ($\leq 0.011 \text{ } \Omega/\text{ft}$)
- Capacitance: core/core, shield grounded: $\leq 120 \text{ pF/m}$ ($\leq 37 \text{ pF/ft}$)
- Operating temperature:
 - Cable not permanently routed: -20 to $+80 \text{ }^\circ\text{C}$ (-4 to $+176 \text{ }^\circ\text{F}$)
 - Cable permanently routed: -40 to $+80 \text{ }^\circ\text{C}$ (-40 to $+176 \text{ }^\circ\text{F}$)
- Cable cross-section: max. 2.5 mm^2 (14 AWG)

Signal cable

- $3 \times 0.38 \text{ mm}^2$ (20 AWG) PVC cable with common, braided copper shield ($\varnothing \sim 7 \text{ mm} / 0.28''$) and individually shielded cores
- With Empty Pipe Detection (EPD): $4 \times 0.38 \text{ mm}^2$ (20 AWG) PVC cable with common, braided copper shield ($\varnothing \sim 7 \text{ mm} / 0.28''$) and individually shielded cores
- Conductor resistance: $\leq 50 \text{ } \Omega/\text{km}$ ($\leq 0.015 \text{ } \Omega/\text{ft}$)
- Capacitance: core/shield: $\leq 420 \text{ pF/m}$ ($\leq 128 \text{ pF/ft}$)
- Operating temperature:
 - Cable not permanently routed: -20 to $+80 \text{ }^\circ\text{C}$ (-4 to $+176 \text{ }^\circ\text{F}$)
 - Cable permanently routed: -40 to $+80 \text{ }^\circ\text{C}$ (-40 to $+176 \text{ }^\circ\text{F}$)
- Cable cross-section: max. 2.5 mm^2 (14 AWG)

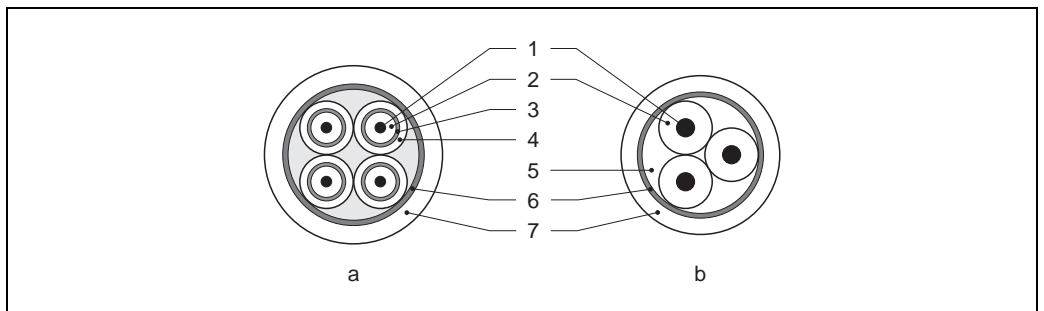

- a *Signal cable*
- b *Coil current cable*
- 1 *Core*
- 2 *Core insulation*
- 3 *Core shield*
- 4 *Core jacket*
- 5 *Core reinforcement*
- 6 *Cable shield*
- 7 *Outer jacket*

As an option, Endress+Hauser can also deliver reinforced connecting cables with an additional, reinforcing metal braid. We recommend such cables for the following cases:

- Directly buried cable
- Cables endangered by rodents
- Device operation which should comply with the IP 68 (NEMA 6P) standard of protection

Operation in zones of severe electrical interference

The measuring device complies with the general safety requirements in accordance with EN 61010-1, the EMC requirements of IEC/EN 61326 and NAMUR recommendation NE 21.



Caution!

Grounding of the shield is by means of the ground terminals provided for the purpose inside the connection housing. Keep the stripped and twisted lengths of cable shield to the terminals as short as possible.

Power consumption

AC: $< 45 \text{ VA}$ at 260 V AC ; $< 32 \text{ VA}$ at 110 V AC (incl. sensor)

DC: $< 19 \text{ W}$ (including sensor)

Switch-on current:

- max. 2.5 A ($< 200 \text{ ms}$) at 24 V DC
- max. 2.5 A ($< 5 \text{ ms}$) at 110 V AC
- max. 5.5 A ($< 5 \text{ ms}$) at 260 V AC

Power supply failure

Lasting min. 1 power cycle:

- EEPROM or HistoROM/T-DAT saves measuring system data if power supply fails
- HistoROM/S-DAT: exchangeable data storage device which stores sensor characteristic data (nominal diameter, serial number, calibration factor, zero point etc.)

Potential equalization**Standard case**

Perfect measurement is only ensured when the medium and the sensor have the same electrical potential. Most Promag sensors have a reference electrode installed as standard, which guarantees the required potential equalization. This usually means that additional potential equalization measures are unnecessary.

Promag S:

- Reference electrode is standard for electrode materials 1.4435/316L, Alloy C-22, tantalum, titanium Gr. 2, Duplex 1.4462, tungsten carbide coating (for electrodes made of 1.4435)
- Reference electrode is optional for electrode material platinum
- Reference electrode not present in measuring tubes with a natural rubber lining in conjunction with brush electrodes



Note!

For installation in metal pipes, it is advisable to connect the ground terminal of the transmitter housing to the piping. Also, observe company-internal grounding guidelines.

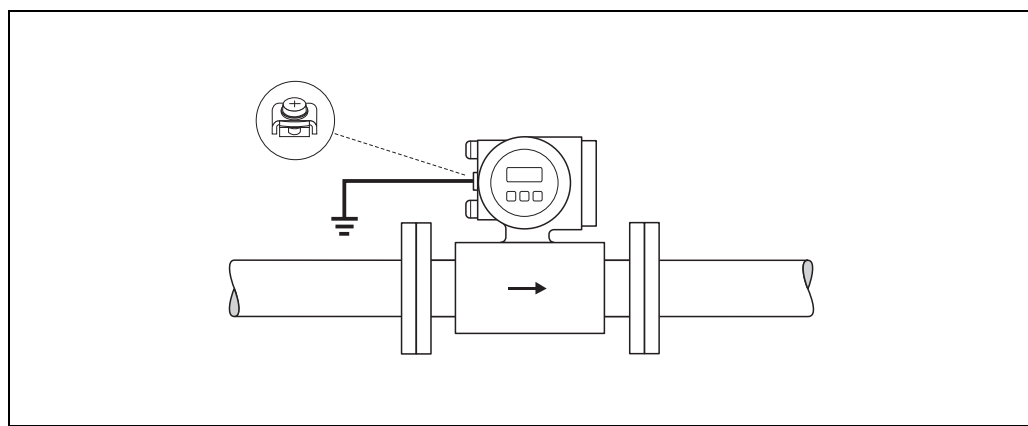

Potential equalization by means of the transmitter's ground terminal



Caution!

- For sensors without reference electrodes or without metal process connections, carry out potential equalization as per the instructions for special cases described below. These special measures are particularly important when standard grounding practice cannot be ensured or extremely strong matching currents are expected.
- Sensors with brush electrodes do not have a reference electrode. For this reason, ground disks must be installed if necessary to ensure sufficient potential equalization to the fluid. This applies in particular to isolating lined pipes which are not grounded → 11.

Special cases

Metal, ungrounded piping

In order to prevent outside influences on measurement, it is necessary to use ground cables to connect each sensor flange to its corresponding pipe flange and ground the flanges. Connect the transmitter or sensor connection housing, as applicable, to ground potential by means of the ground terminal provided for the purpose (see diagram).

The ground cable for flange-to-flange connections can be ordered separately as an accessory from Endress+Hauser → 46.

- $DN \leq 300$ (12"): The ground cable is in direct connection with the conductive flange coating and is secured by the flange screws (A).
- $DN \geq 350$ (14"): The ground cable connects directly to the metal transport bracket (B).



Caution!

Also, observe company-internal grounding guidelines.

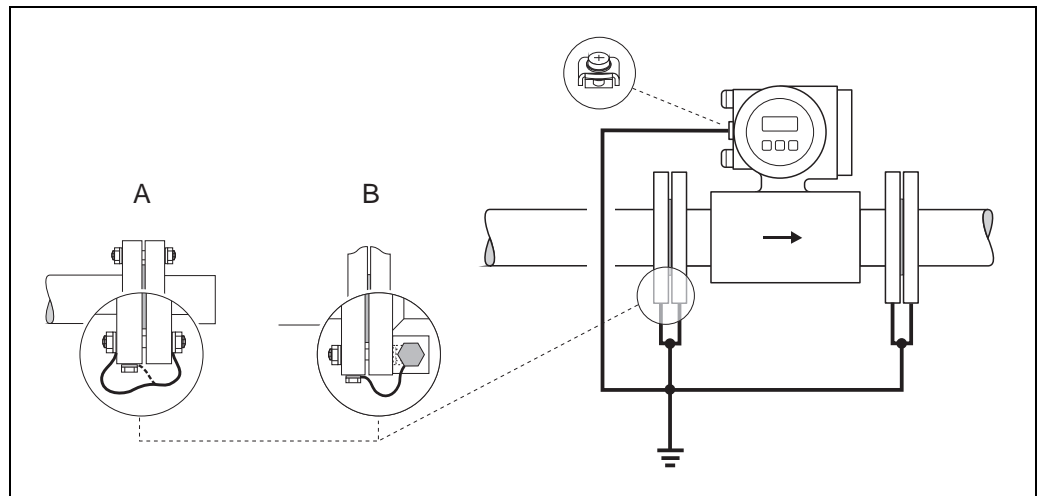

A0004376

*Potential equalization with equalizing currents in ungrounded, metal pipes
(ground cable: copper wire, at least 6 mm² / 10 AWG)*

- A Installing ground cable at $DN \leq 300$ (12")
- B Installing ground cable at $DN \geq 350$ (14")

Pre-installed ground cable for $DN \leq 300$ (12") (order option)

Ground cables which are preinstalled on the sensor flange, are also available. These ground cables can be mounted and connected electrically to the piping in different ways:

- Using a screw on the side of the pipe flange (a)
- Using the flange screws (b)
- Using a pipe clip installed around the pipe (c)

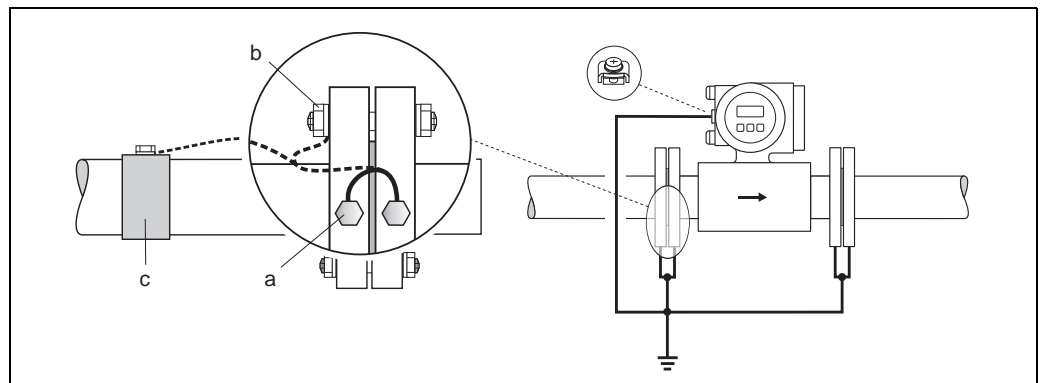

A0006117

*Possibilities for connecting and mounting pre-installed ground cables
(ground cable: copper wire at least 6 mm² / 10 AWG)*

Plastic pipes and isolating lined pipes

Normally, potential is matched using the reference electrodes in the measuring tube. However, in exceptional cases it is possible that, due to the grounding plan of a system, matching currents flow over the reference electrodes. This can lead to destruction of the sensor, e.g. through electro-chemical decomposition of the electrodes. In such cases, e.g. for fiberglass or PVC pipings, it is therefore **essential** that you use additional ground disks for potential equalization. This applies also to two-phase or two-component flow, where the fluid is not well mixed or its constituents are not mixable.



Caution!

- Risk of damage by electrochemical corrosion. Note the electrochemical insulation rating, if the ground disks and measuring electrodes are made of different materials.
- Also, observe company-internal grounding guidelines.

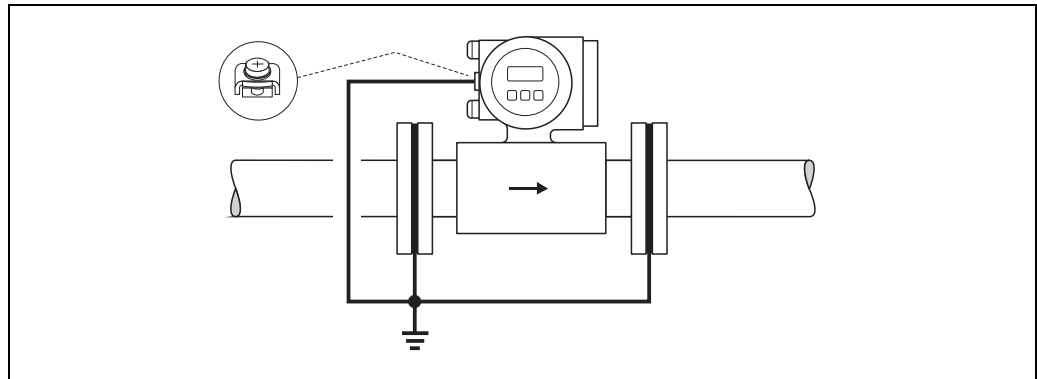

A0004377

Potential equalization/ground disks in the case of plastic pipes or isolating lined pipes
(ground cable: copper wire at least 6 mm² / 10 AWG)

Plastic pipes and isolating lined pipes

In such cases, install the measuring instrument without potential in the piping:

- When installing the measuring device, make sure that there is an electrical connection between the two piping runs (copper wire, at least 6 mm² / 10 AWG).
- When using ground disks in plastic or isolating lined pipes, ensure that they are electrically connected with each other (copper wire at least 6 mm² / 10 AWG).
- Make sure that the mounting material used does not establish a conductive connection between the pipe and the measuring device and that the mounting material withstands the torques applied when the threaded fasteners are tightened during installation.
- Check the galvanic isolation using an insulation tester (protection against contact).
- Also comply with the regulations applicable to potential-free installation.



Note!

For the remote version, both the sensor and the transmitter must be installed so that they are potential-free.

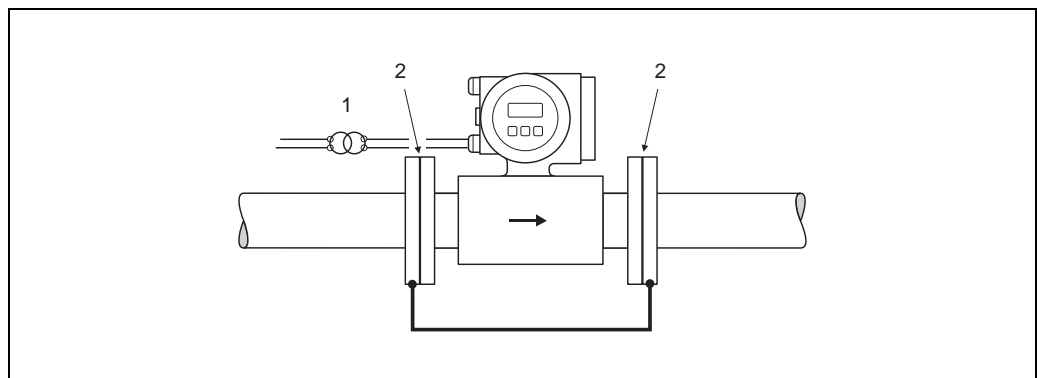

A0004378

Potential equalization and cathodic protection (connecting cable: copper wire at least 6 mm² / 10 AWG)

- 1 Isolation transformer power supply
- 2 Electrically insulated

Performance characteristics

Reference conditions

To DIN EN 29104 and VDI/VDE 2641:

- Fluid temperature: $+28\text{ °C} \pm 2\text{ K}$ ($+82\text{ °F} \pm 2\text{ K}$)
- Ambient temperature: $+22\text{ °C} \pm 2\text{ K}$ ($+72\text{ °F} \pm 2\text{ K}$)
- Warm-up time: 30 minutes

Installation:

- Inlet run $> 10 \times \text{DN}$
- Outlet run $> 5 \times \text{DN}$
- Sensor and transmitter grounded.
- Sensor centered relative to the pipe.

Maximum measured error

Pulse output:

- Standard: $\pm 0.2\%$ o.r. $\pm 2\text{ mm/s}$ ($\pm 0.2\%$ o.r. $\pm 0.08\text{ in/s}$)
- With brush electrodes (Option): $\pm 0.5\%$ o.r. $\pm 2\text{ mm/s}$ ($\pm 0.5\%$ o.r. $\pm 0.08\text{ in/s}$)
(o.r. = of reading)

Current output:

in addition typically $\pm 5\text{ }\mu\text{A}$



Note!

Supply-voltage fluctuations have no effect within the specified range.

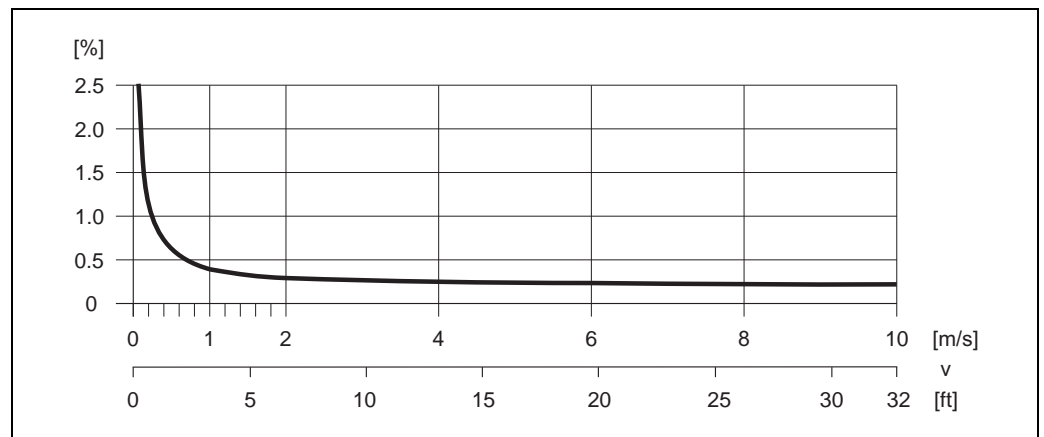

Max. measured error in % of reading

Conductivity

- Max. measuring error not specified
- Without temperature compensation (cell constant is a factory setting)

Repeatability

Volume flow

- Standard: max. $\pm 0.1\%$ o.r. $\pm 0.5\text{ mm/s}$ ($\pm 0.1\%$ o.r. $\pm 0.02\text{ in/s}$)
- With brush electrodes (Option): max. $\pm 0.2\%$ o.r. $\pm 0.5\text{ mm/s}$ ($\pm 0.2\%$ o.r. $\pm 0.02\text{ in/s}$)
(o.r. = of reading)

Conductivity

- Max. $\pm 5\%$ o.r.
(o.r. = of reading)

Operating conditions: Installation

Installation instructions

Location

The accumulation of air or gas bubbles in the measuring tube could result in an increase in measuring errors.

Avoid the following locations:

- At the highest point of a pipeline. Risk of air accumulating.
- Directly upstream from a free pipe outlet in a vertical pipeline.

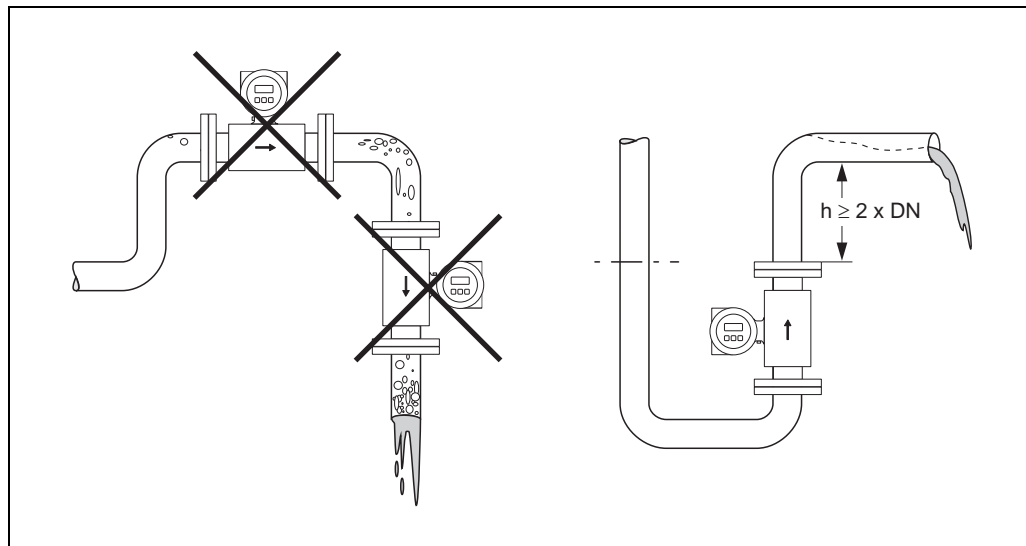

A0003202

Installing pumps

Do not install the sensor on the intake side of a pump. This precaution is to avoid low pressure and the consequent risk of damage to the lining of the measuring tube. Information on the lining's resistance to partial vacuum → 22.

It might be necessary to install pulse dampers in systems incorporating reciprocating, diaphragm or peristaltic pumps. Information on the measuring system's resistance to vibration and shock → 20.

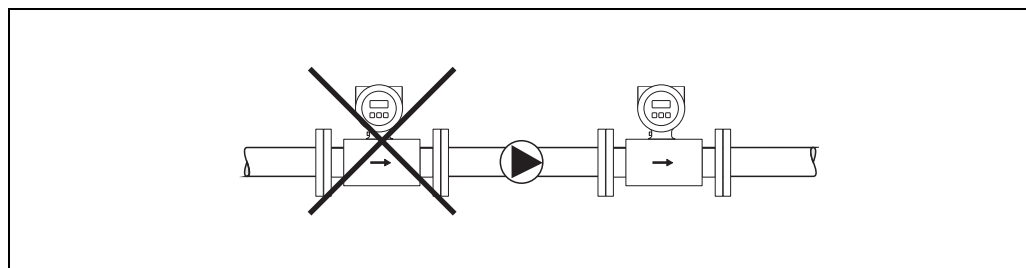

A0003203

Partially filled pipes

Partially filled pipes with gradients necessitate a drain-type configuration. The Empty Pipe Detection function offers additional protection by detecting empty or partially filled pipes.



Caution!

Risk of solids accumulating. Do not install the sensor at the lowest point in the drain. It is advisable to install a cleaning valve.

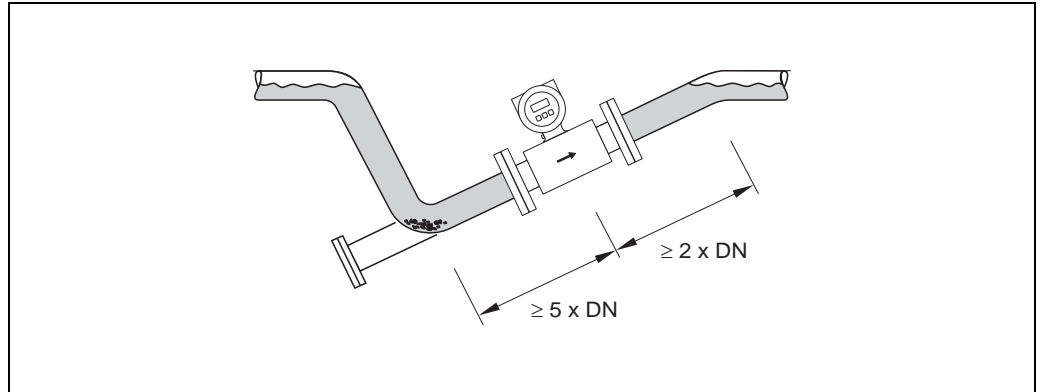

A0003204

Down pipes

Install a siphon or a vent valve downstream of the sensor in down pipes $h \geq 5$ m (16,4 ft). This precaution is to avoid low pressure and the consequent risk of damage to the lining of the measuring tube. This measure also prevents the system losing prime, which could cause air inclusions.

Information on the lining's resistance to partial vacuum → 22.

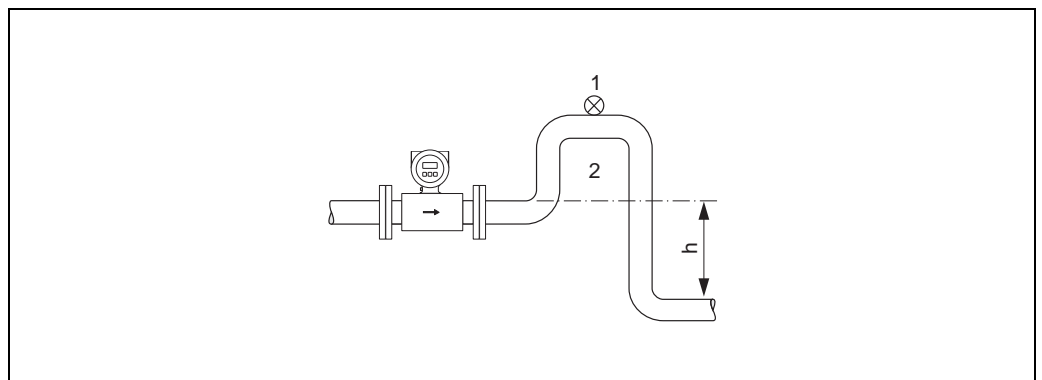

A0008157

Measures for installation in a down pipe

- 1 Vent valve
- 2 Siphon
- h Vertical height of the down pipe regarding the sensor

Orientation

An optimum orientation position helps avoid gas and air accumulations and deposits in the measuring tube. Promag, nevertheless, supplies a range of functions and accessories for correct measuring of problematic fluids:

- Electrode Cleaning Circuit (ECC) for applications with fluids producing build-up, e.g. electrically conductive deposits → "Description of Device Functions" manual.
- Empty Pipe Detection (EPD) ensures the detection of partially filled measuring tubes, e.g. in the case of degassing fluids.

Vertical orientation

A vertical orientation is ideal in the following cases:

- For self-emptying piping systems and when using empty pipe detection.
- For sludge containing sand or stones and where the solids cause sedimentation.

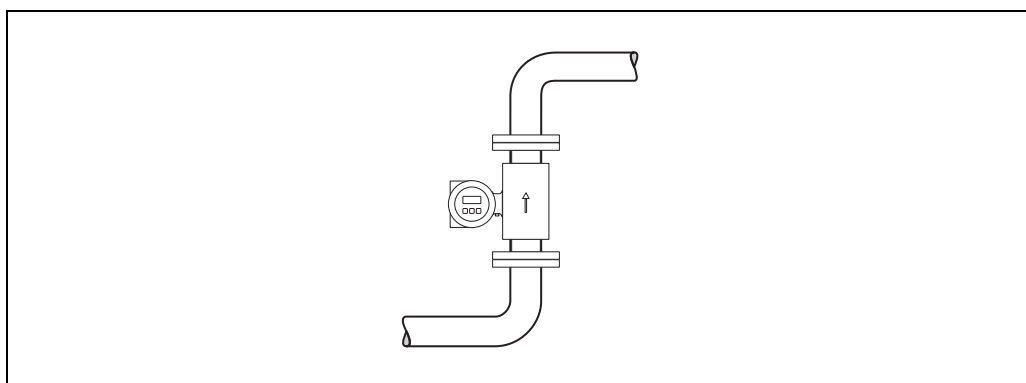

A0008158

Horizontal orientation

The measuring electrode plane should be horizontal. This prevents brief insulation of the two electrodes by entrained air bubbles.



Caution!

Empty Pipe Detection functions correctly with the measuring device installed horizontally only when the transmitter housing is facing upward (see diagram). Otherwise there is no guarantee that Empty Pipe Detection will respond if the measuring tube is only partially filled or empty.

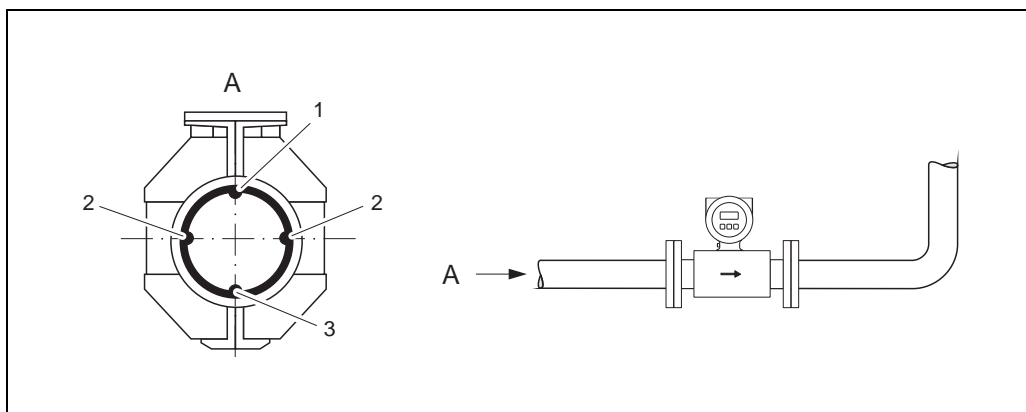

A0003207

- 1 EPD electrode for empty pipe detection (not available for "measuring electrode only" option)
- 2 Measuring electrodes for signal detection
- 3 Reference electrode for potential equalization (not available for "measuring electrode only" option)

Vibrations

Secure and fix both the piping and the sensor if the vibrations are severe.



Caution!

It is advisable to install sensor and transmitter separately if vibration is excessively severe. Information on the permitted resistance to vibration and shock → 20.

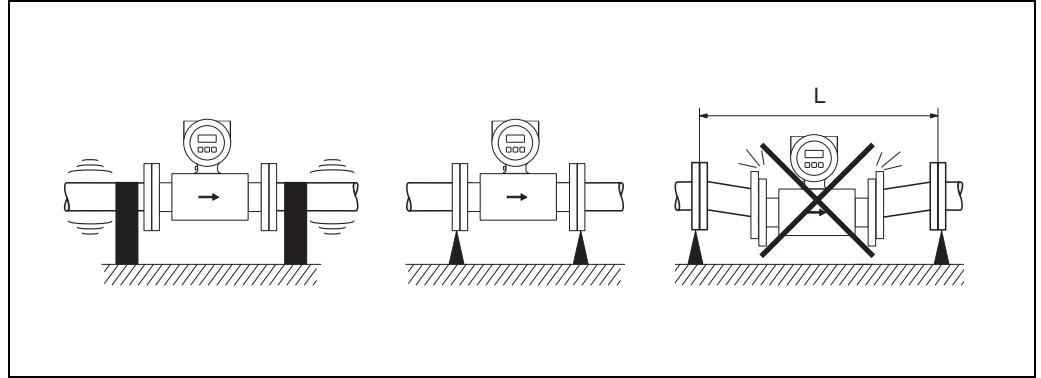

Measures to prevent vibration of the measuring device ($L > 10\text{ m} / 33\text{ ft}$)

Foundations, supports

If the nominal diameter is $DN \geq 350$ (14"), mount the sensor on a foundation of adequate load-bearing strength.



Caution!

Risk of damage.

Do not support the weight of the sensor on the metal casing; the casing would buckle and damage the internal magnetic coils.

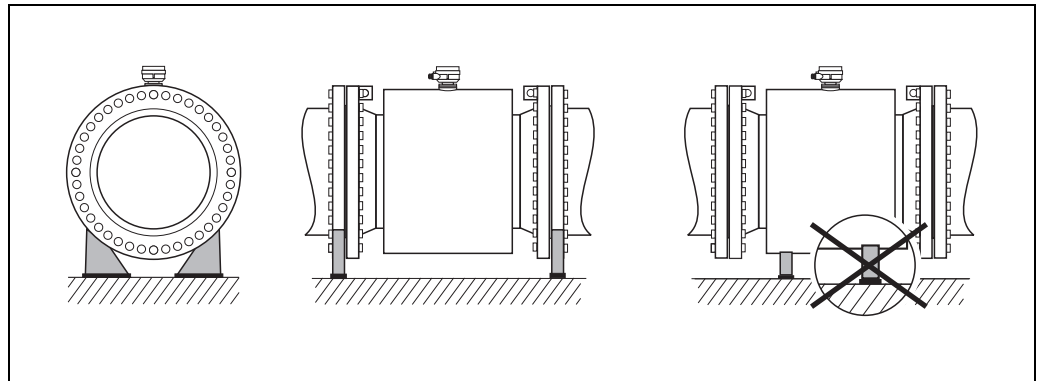

Correct support for large nominal diameters ($DN \geq 350 / 14''$)

Adapters

Suitable adapters to DIN EN 545 (double-flange reducers) can be used to install the sensor in larger-diameter pipes. The resultant increase in the rate of flow improves measuring accuracy with very slow-moving fluids. The nomogram shown here can be used to calculate the pressure loss caused by cross-section reduction.



Note!

The nomogram applies to fluids of viscosity similar to water.

1. Calculate the ratio of the diameters d/D .
2. From the nomogram, read off the pressure loss as a function of fluid velocity (*downstream* from the reduction) and the d/D ratio.

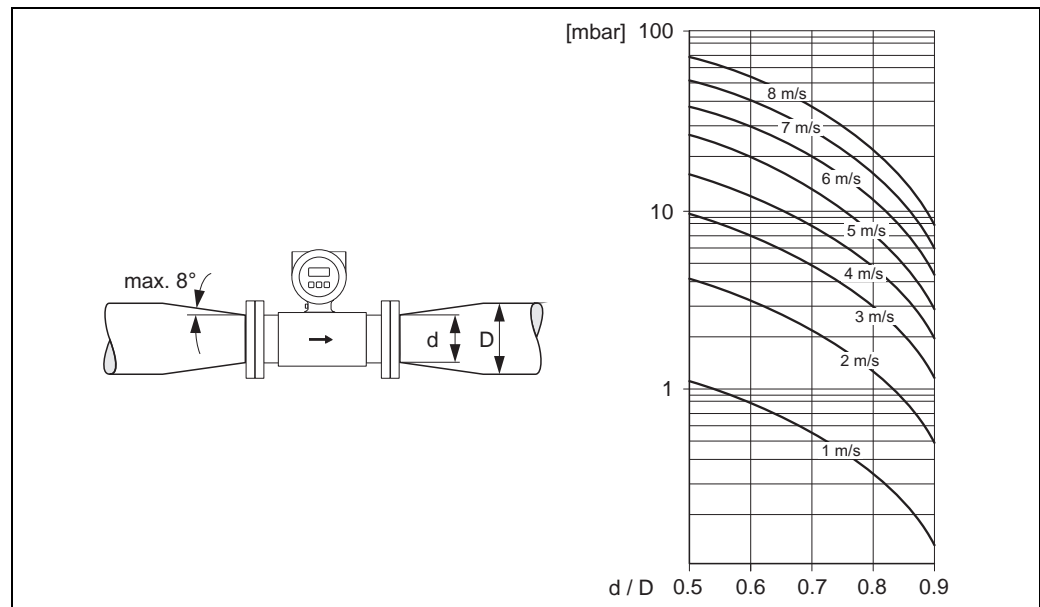

A0003215

Pressure loss due to adapters (for pressure losses in US units, please contact Endress+Hauser)

Inlet and outlet runs

If possible, install the sensor well clear of fittings such as valves, T-pieces, elbows etc.

Compliance with the following requirements for the inlet and outlet runs is necessary in order to ensure measuring accuracy.

- Inlet run $\geq 5 \times DN$
- Outlet run $\geq 2 \times DN$

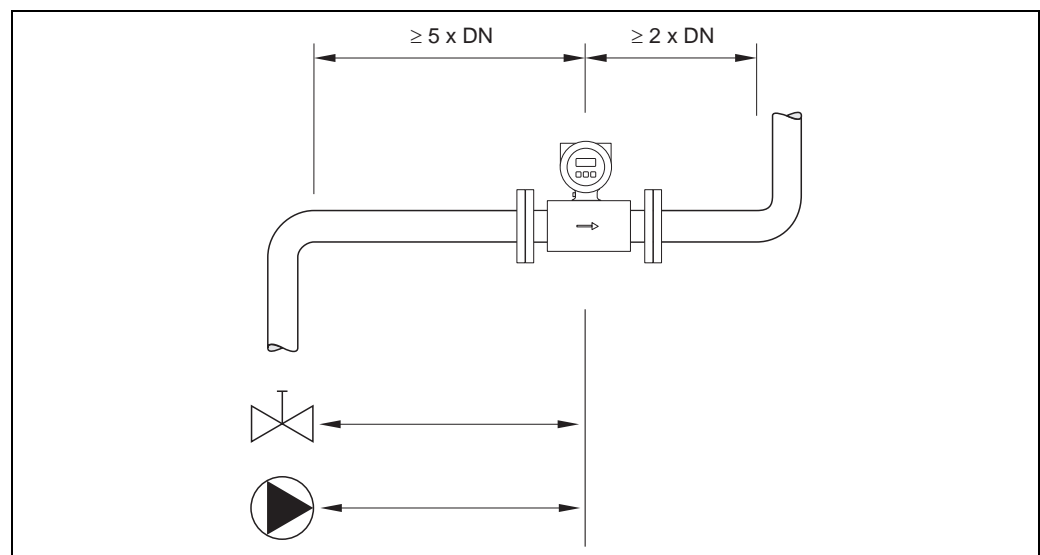

A0003210

Length of connecting cable

In order to ensure measuring accuracy, comply with the following instructions when installing the remote version:

- Secure the cable run or route the cable in an armored conduit. Movement of the cable can falsify the measuring signal, particularly if the fluid conductivity is low.
- Route the cable well clear of electrical machines and switching elements.
- Ensure potential equalization between sensor and transmitter, if necessary.
- The permissible cable length L_{max} depends on the fluid conductivity (see Figure).
- The maximum connecting cable length is 10 m (32.8 ft) when empty pipe detection (EPD) is switched on.

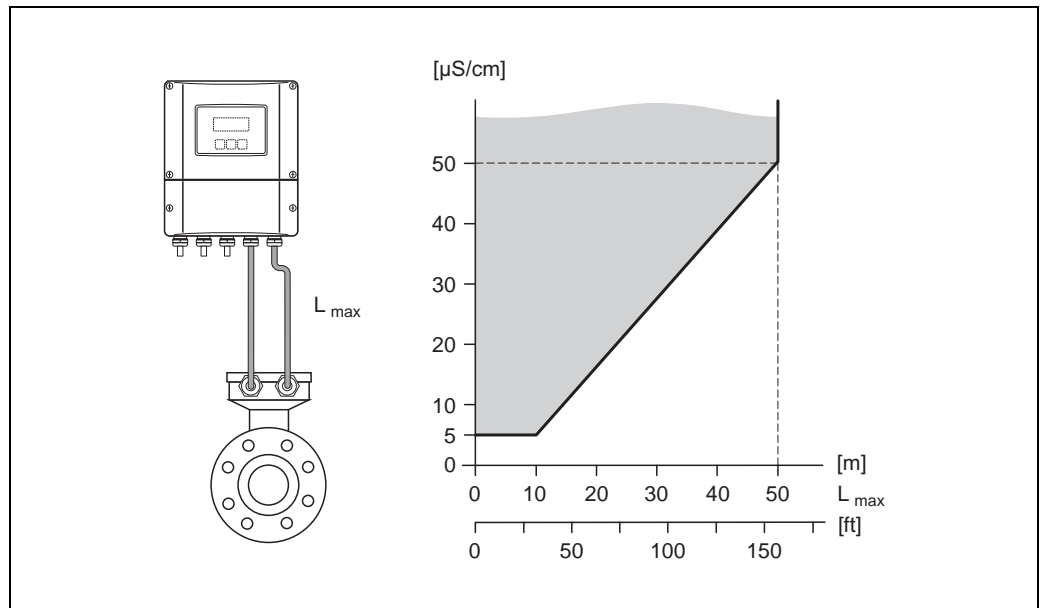

Permitted lengths for connecting cable in remote version, as a function of the conductivity of the fluid

Gray shaded area = permissible area

L_{max} = Length of connecting cable

A0000110

Operating conditions: Environment

Ambient temperature

Transmitter:

- Standard:
 - Compact version: -20 to $+50$ °C (-4 to $+122$ °F)
 - Remote version: -20 to $+60$ °C (-4 to $+140$ °F)
- Optional:
 - Compact version: -40 to $+50$ °C (-40 to $+122$ °F)
 - Remote version: -40 to $+60$ °C (-40 to $+140$ °F)



Note!

At ambient temperatures below -20 °C (-4 °F), the readability of the display may be impaired.

Sensor:

- Flange material carbon steel: -10 to $+60$ °C ($+14$ to $+140$ °F)
- Flange material stainless steel: -40 to $+60$ °C (-40 to $+140$ °F)



Caution!

Do not exceed the min. and max. temperatures for the lining of the measuring tube (→ "Medium temperature range").

Note the following points:

- Install the device at a shady location. Avoid direct sunlight, particularly in warm climatic regions.
- If both fluid and ambient temperatures are high, install the transmitter at a remote location from the sensor (→ "Medium temperature range").

Storage temperature

The storage temperature corresponds to the operating temperature range of the transmitter and sensor.

Degree of protection

- Standard: IP 67 (NEMA 4X) for transmitter and sensor
- Optional: IP 68 (NEMA 6P) for remote version of Promag S sensor
- For information regarding applications where the device is buried directly in the soil or is installed in a flooded wastewater basin please contact your local Endress+Hauser Sales Center.

Shock and vibration resistance

Acceleration up to 2 g by analogy with IEC 600 68-2-6
(High temperature version: no data available)

Electromagnetic compatibility (EMC)

According to IEC/EN 61326 and NAMUR recommendation NE 21

Operating conditions: Process

Medium temperature range

The permitted temperature depends on the lining of the measuring tube:

- 0 to +60 °C (+32 to +140 °F) for natural rubber (DN 65 to 600 / 2½ to 24")
- 0 to +80 °C (+32 to +176 °F) for hard rubber (DN 65 to 600 / 2½ to 24")
- -20 to +50 °C (-4 to +122 °F) for polyurethane (DN 25 to 600 / 1 to 24")
- -20 to +180 °C (-4 to +356 °F) for PFA (DN 25 to 200 / 1 to 8"), restrictions → see diagrams
- -40 to +130 °C (-40 to +266 °F) for PTFE (DN 15 to 600 / ½ to 24"), restrictions → see diagrams

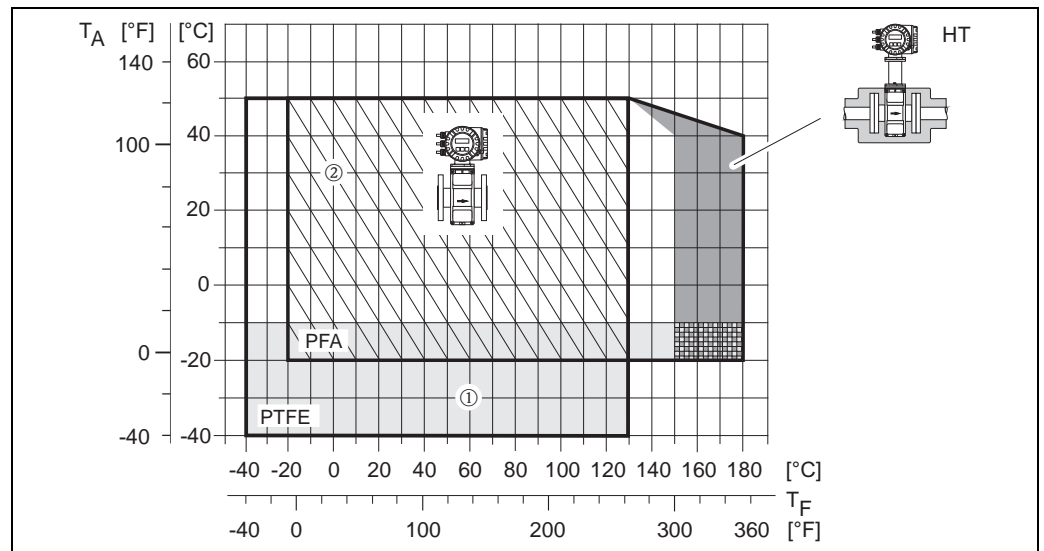

Promag S compact versions (with PFA or PTFE lining)

T_A Ambient temperature

T_F Fluid temperature

HT High temperature version with insulation

① Gray shaded area → temperature range from -10 to -40 °C (-14 to -40 °F) applies only to stainless steel flanges

② HE + IP 68 to 130 °C (266 °F) only

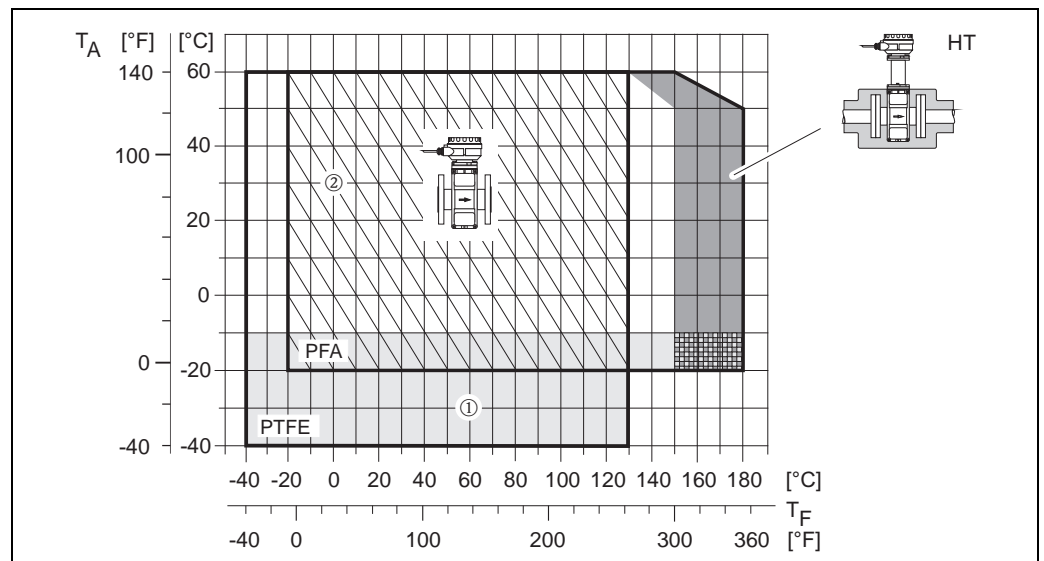

Promag S remote versions (with PFA or PTFE lining)

T_A Ambient temperature

T_F Fluid temperature

HT High temperature version with insulation

① Gray shaded area → temperature range from -10 to -40 °C (-14 to -40 °F) applies only to stainless steel flanges

② HE + IP 68 to 130 °C (266 °F) only

Conductivity

Minimum conductivity:
 ■ $\geq 5 \mu\text{S/cm}$ for all liquids (incl. demineralized water)



Note!
 In the remote version, the required minimum conductivity is also influenced by the length of the cable
 → 19.

Limiting medium pressure range (nominal pressure)

- EN 1092-1 (DIN 2501): PN 10 (DN 200 to 600 / 8 to 24"), PN 16 (DN 65 to 600 / 2½ to 24"), PN 25 (DN 200 to 600 / 8 to 24"), PN 40 (DN 15 to 150 / ½ to 6")
- ANSI B16.5: Class 150 (DN ½ to 24"), Class 300 (DN ½ to 6")
- JIS B2220: 10K (DN 50 to 300 / 2 to 12"), 20K (DN 15 to 300 / ½ to 12")
- AS 2129: Table E (DN 25 / 1", DN 50 / 2")
- AS 4087: PN 16 (DN 50 / 2")

Pressure tightness (lining)**Pressure tightness in SI units [mbar]**

Promag S Nominal diameter [mm]	Measuring tube lining	Resistance of measuring tube lining to partial vacuum (SI units) Limit values for abs. pressure [mbar] at various fluid temperatures						
		25 °C	50 °C	80 °C	100 °C	130 °C	150 °C	180 °C
25 to 600	Polyurethane	0	0	-	-	-	-	-
65 to 600	Natural rubber	0	0	-	-	-	-	-
65 to 600	Hard rubber	0	0	0	-	-	-	-

Promag S Nominal diameter [mm]	Measuring tube lining	Resistance of measuring tube lining to partial vacuum (SI units) Limit values for abs. pressure [mbar] at various fluid temperatures					
		25 °C	80 °C	100 °C	130 °C	150 °C	180 °C
15	PTFE	0	0	0	100	-	-
25	PTFE / PFA	0/0	0/0	0/0	100/0	-/0	-/0
32	PTFE / PFA	0/0	0/0	0/0	100/0	-/0	-/0
40	PTFE / PFA	0/0	0/0	0/0	100/0	-/0	-/0
50	PTFE / PFA	0/0	0/0	0/0	100/0	-/0	-/0
65	PTFE / PFA	0/0	*	40/0	130/0	-/0	-/0
80	PTFE / PFA	0/0	*	40/0	130/0	-/0	-/0
100	PTFE / PFA	0/0	*	135/0	170/0	-/0	-/0
125	PTFE / PFA	135/0	*	240/0	385/0	-/0	-/0
150	PTFE / PFA	135/0	*	240/0	385/0	-/0	-/0
200	PTFE / PFA	200/0	*	290/0	410/0	-/0	-/0
250	PTFE	330	*	400	530	-	-
300	PTFE	400	*	500	630	-	-
350	PTFE	470	*	600	730	-	-
400	PTFE	540	*	670	800	-	-
450	PTFE	Partial vacuum is impermissible!					
500	PTFE						
600	PTFE						
* No value can be quoted.							

Pressure tightness in US units [psi = pounds/inch²]

Promag S Nominal diameter [inch]	Measuring tube lining	Resistance of measuring tube lining to partial vacuum (US units) Limit values for abs. pressure [psi] at various fluid temperatures						
		77 °F	122 °F	176 °F	212 °F	266 °F	302 °F	356 °F
1 to 24"	Polyurethane	0	0	-	-	-	-	-
3 to 24"	Natural rubber	0	0	-	-	-	-	-
3 to 24"	Hard rubber	0	0	0	-	-	-	-

Promag S Nominal diameter [inch]	Measuring tube lining	Resistance of measuring tube lining to partial vacuum (US units) Limit values for abs. pressure [psi] at various fluid temperatures					
		77 °F	176 °F	212 °F	266 °F	302 °F	356 °F
½"	PTFE	0	0	0	1.5	-	-
1"	PTFE / PFA	0/0	0/0	0/0	1.5/0	-/0	-/0
-	PTFE / PFA	0/0	0/0	0/0	1.5/0	-/0	-/0
1½"	PTFE / PFA	0/0	0/0	0/0	1.5/0	-/0	-/0
2"	PTFE / PFA	0/0	0/0	0/0	1.5/0	-/0	-/0
-	PTFE / PFA	0/0	*	0.6/0	1.9/0	-/0	-/0
3"	PTFE / PFA	0/0	*	0.6/0	1.9/0	-/0	-/0
4"	PTFE / PFA	0/0	*	2.0/0	2.5/0	-/0	-/0
-	PTFE / PFA	2.0/0	*	3.5/0	5.6/0	-/0	-/0
6"	PTFE / PFA	2.0/0	*	3.5/0	5.6/0	-/0	-/0
8"	PTFE / PFA	2.9/0	*	4.2/0	5.9/0	-/0	-/0
10"	PTFE	4.8	*	5.8	7.7	-	-
12"	PTFE	5.8	*	7.3	9.1	-	-
14"	PTFE	6.8	*	8.7	10.6	-	-
16"	PTFE	7.8	*	9.7	11.6	-	-
18"	PTFE	Partial vacuum is impermissible!					
20"	PTFE						
24"	PTFE						
* No value can be quoted.							

Nominal diameter and flow rate

The diameter of the pipe and the flow rate determine the nominal diameter of the sensor. The optimum flow velocity is between 2 and 3 m/s (6 to 10 ft/s). The flow velocity (v), moreover, has to be matched to the physical properties of the fluid:

- $v < 2$ m/s (6 ft/s): for abrasive fluids where solids do not cause sedimentation (e.g. lime milk)
- $v > 2$ m/s (6 ft/s): for fluids producing build-up (e.g. wastewater sludge)
- $v > 2$ m/s (6 ft/s): for abrasive sludge with a high sand or stone content and where the solids easily cause sedimentation (e.g. ore slurry)



Note!

Flow velocity can be increased, if necessary, by reducing the nominal diameter of the sensor through the use of adapters → 18.

Flow rate characteristic values - Promag S (SI units)				
Nominal diameter [mm]	Recommended flow rate min./max. full scale value ($v \approx 0.3$ or 10 m/s)	Factory settings		
		Full scale value ($v \approx 2.5$ m/s)	Pulse value (≈ 2 pulse/s)	Low flow cut off ($v \approx 0.04$ m/s)
15	4 to 100 dm ³ /min	25 dm ³ /min	0.20 dm ³	0.5 dm ³ /min
25	9 to 300 dm ³ /min	75 dm ³ /min	0.50 dm ³	1 dm ³ /min
32	15 to 500 dm ³ /min	125 dm ³ /min	1.00 dm ³	2 dm ³ /min
40	25 to 700 dm ³ /min	200 dm ³ /min	1.50 dm ³	3 dm ³ /min
50	35 to 1100 dm ³ /min	300 dm ³ /min	2.50 dm ³	5 dm ³ /min
65	60 to 2000 dm ³ /min	500 dm ³ /min	5.00 dm ³	8 dm ³ /min
80	90 to 3000 dm ³ /min	750 dm ³ /min	5.00 dm ³	12 dm ³ /min
100	145 to 4700 dm ³ /min	1200 dm ³ /min	10.00 dm ³	20 dm ³ /min
125	220 to 7500 dm ³ /min	1850 dm ³ /min	15.00 dm ³	30 dm ³ /min
150	20 to 600 m ³ /h	150 m ³ /h	0.025 m ³	2.5 m ³ /h
200	35 to 1100 m ³ /h	300 m ³ /h	0.05 m ³	5.0 m ³ /h
250	55 to 1700 m ³ /h	500 m ³ /h	0.05 m ³	7.5 m ³ /h
300	80 to 2400 m ³ /h	750 m ³ /h	0.10 m ³	10 m ³ /h
350	110 to 3300 m ³ /h	1000 m ³ /h	0.10 m ³	15 m ³ /h
400	140 to 4200 m ³ /h	1200 m ³ /h	0.15 m ³	20 m ³ /h
450	180 to 5400 m ³ /h	1500 m ³ /h	0.25 m ³	25 m ³ /h
500	220 to 6600 m ³ /h	2000 m ³ /h	0.25 m ³	30 m ³ /h
600	310 to 9600 m ³ /h	2500 m ³ /h	0.30 m ³	40 m ³ /h

Flow rate characteristic values - Promag S (US units)				
Nominal diameter [inch]	Recommended flow rate min./max. full scale value ($v \approx 1.0$ or 33 ft/s)	Factory settings		
		Full scale value ($v \approx 8.2$ ft/s)	Pulse value (≈ 2 pulse/s)	Low flow cut off ($v \approx 0.1$ ft/s)
½"	1.0 to 27 gal/min	6 gal/min	0.05 gal	0.10 gal/min
1"	2.5 to 80 gal/min	18 gal/min	0.20 gal	0.25 gal/min
1¼"	4 to 130 gal/min	30 gal/min	0.20 gal	0.50 gal/min
1½"	7 to 190 gal/min	50 gal/min	0.50 gal	0.75 gal/min
2"	10 to 300 gal/min	75 gal/min	0.50 gal	1.25 gal/min
2½"	16 to 500 gal/min	130 gal/min	1 gal	2.0 gal/min
3"	24 to 800 gal/min	200 gal/min	2 gal	2.5 gal/min
4"	40 to 1250 gal/min	300 gal/min	2 gal	4.0 gal/min
5"	60 to 1950 gal/min	450 gal/min	5 gal	7.0 gal/min
6"	90 to 2650 gal/min	600 gal/min	5 gal	12 gal/min
8"	155 to 4850 gal/min	1200 gal/min	10 gal	15 gal/min
10"	250 to 7500 gal/min	1500 gal/min	15 gal	30 gal/min
12"	350 to 10600 gal/min	2400 gal/min	25 gal	45 gal/min
14"	500 to 15000 gal/min	3600 gal/min	30 gal	60 gal/min
16"	600 to 19000 gal/min	4800 gal/min	50 gal	60 gal/min
18"	800 to 24000 gal/min	6000 gal/min	50 gal	90 gal/min
20"	1000 to 30000 gal/min	7500 gal/min	75 gal	120 gal/min
24"	1400 to 44000 gal/min	10500 gal/min	100 gal	180 gal/min

Pressure loss

- No pressure loss if the sensor is installed in a pipe of the same nominal diameter.
- Pressure losses for configurations incorporating adapters according to DIN EN 545 →  18.

Measuring tube specifications

Measuring tube specifications - Promag S (SI units)										
Nominal diameter		Pressure rating					Inside diameter of measuring tube			
[mm]	[inch]	EN (DIN) [bar]	AS 2129	AS 4087	ANSI [lbs]	JIS	with PFA [mm]	with PTFE [mm]	PU ¹⁾ [mm]	HR ¹⁾ [mm]
15	½"	PN 40	–	–	CI 150	20K	–	15	–	–
25	1"	PN 40	Table E	–	CI 150	20K	23	26	24	–
32	–	PN 40	–	–	–	20K	32	35	32	–
40	1½"	PN 40	–	–	CI 150	20K	36	41	38	–
50	2"	PN 40	Table E	PN 16	CI 150	10K	48	52	50	50
65	–	PN 16	–	–	–	10K	63	67	66	66
80	3"	PN 16	Table E	PN 16	CI 150	10K	75	80	79	79
100	4"	PN 16	Table E	PN 16	CI 150	10K	101	104	102	102
125	–	PN 16	–	–	–	10K	126	129	127	127
150	6"	PN 16	Table E	PN 16	CI 150	10K	154	156	156	156
200	8"	PN 10	Table E	PN 16	CI 150	10K	201	202	204	204
250	10"	PN 10	Table E	PN 16	CI 150	10K	–	256	258	258
300	12"	PN 10	Table E	PN 16	CI 150	10K	–	306	309	309
350	14"	PN 10	Table E	PN 16	CI 150	–	–	337	342	342
400	16"	PN 10	Table E	PN 16	CI 150	–	–	387	392	392
450	18"	PN 10	Table E	PN 16	CI 150	–	–	432	437	437
500	20"	PN 10	Table E	PN 16	CI 150	–	–	487	492	492
600	24"	PN 10	Table E	PN 16	CI 150	–	–	593	594	594
¹⁾ Abbreviations (lining): PU = Polyurethane, HR = Hard rubber										

Measuring tube specifications - Promag S (US units)										
Nominal diameter		Pressure rating					Inside diameter of measuring tube			
[inch]	[mm]	EN (DIN) [bar]	AS 2129	AS 4087	ANSI [lbs]	JIS	with PFA [inch]	with PTFE [inch]	PU ¹⁾ [inch]	HR ¹⁾ [inch]
½"	15	PN 40	–	–	Cl 150	20K	–	0.59	–	–
1"	25	PN 40	Table E	–	Cl 150	20K	0.91	1.02	0.94	–
–	32	PN 40	–	–	–	20K	1.26	1.34	1.26	–
1½"	40	PN 40	–	–	Cl 150	20K	1.42	1.61	1.50	–
2"	50	PN 40	Table E	PN 16	Cl 150	10K	1.89	2.05	1.97	1.97
–	65	PN 16	–	–	–	10K	2.48	2.64	2.60	2.60
3"	80	PN 16	–	–	Cl 150	10K	2.95	3.15	3.11	3.11
4"	100	PN 16	–	–	Cl 150	10K	3.98	4.09	4.02	4.02
–	125	PN 16	–	–	–	10K	4.96	5.08	5.00	5.00
6"	150	PN 16	–	–	Cl 150	10K	6.06	6.14	6.14	6.14
8"	200	PN 10	–	–	Cl 150	10K	7.91	7.92	8.03	8.03
10"	250	PN 10	–	–	Cl 150	10K	–	10.08	10.16	10.16
12"	300	PN 10	–	–	Cl 150	10K	–	12.05	12.17	12.17
14"	350	PN 10	–	–	Cl 150	–	–	13.27	13.46	13.46
16"	400	PN 10	–	–	Cl 150	–	–	15.24	15.43	15.43
18"	450	PN 10	–	–	Cl 150	–	–	17.01	17.20	17.20
20"	500	PN 10	–	–	Cl 150	–	–	19.17	19.37	19.37
24"	600	PN 10	–	–	Cl 150	–	–	23.35	23.39	23.39
¹⁾ Abbreviations (lining): PU = Polyurethane, HR = Hard rubber										

Nominal diameter		Inside diameter of measuring tube with natural rubber		Thickness of lining material natural rubber		
		[inch]	[mm]	[inch]	[mm]	
2½" 3" 4" 5" 6" 8"	65	PN 16/150 lbs	2.05	52	0.39	10
	80		2.56	65	0.39	10
	100		3.58	91	0.39	10
	125		4.57	116	0.39	10
	150		5.59	142	0.47	12
	200		6.30	190	0.47	12
10" 12" 14" 16" 18" 20" 24"	250	PN 10	9.61	244	0.47	12
	300		11.50	292	0.51	13
	350		12.68	322	0.55	14
	400		14.53	369	0.63	16
	450		16.42	417	0.55	14
	500		18.35	466	0.67	17
10" 12" 14" 16" 18" 20" 24"	600	150 lbs	22.13	562	0.79	20
	250		9.57	243	0.47	12
	300		11.46	291	0.47	12
	350		12.60	320	0.51	13
	400		14.49	368	0.55	14
	450		16.42	417	0.55	14
	500		18.31	465	0.63	16
600	22.17	563	0.63	16		

Mechanical construction

Design, dimensions

Transmitter wall-mount housing (non hazardous area and II3G / zone 2)

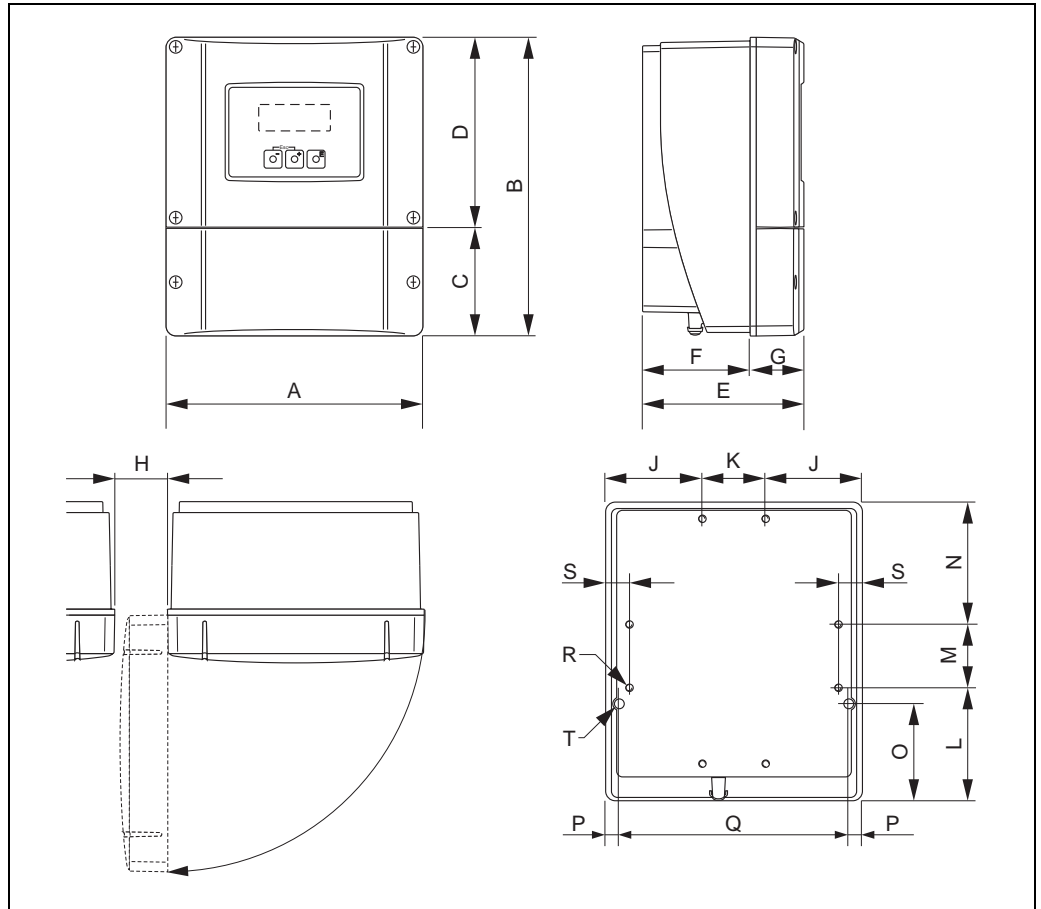

A0001150

Dimensions (SI units)

A	B	C	D	E	F	G	H	J	K
215	250	90.5	159.5	135	90	45	> 50	81	53
L	M	N	O	P	Q	R	S	T ¹⁾	
95	53	102	81.5	11.5	192	8 × M5	20	2 × Ø 6.5	

¹⁾ Securing screw for wall mounting: M6 (screw head max. 10.5 mm)
All dimensions in [mm]

Dimensions (US units)

A	B	C	D	E	F	G	H	J	K
8.46	9.84	3.56	6.27	5.31	3.54	1.77	> 1.97	3.18	2.08
L	M	N	O	P	Q	R	S	T ¹⁾	
3.74	2.08	4.01	3.20	0.45	7.55	8 × M5	0.79	2 × Ø 0.26	

¹⁾ Securing screw for wall mounting: M6 (screw head max. 0.41")
All dimensions in [inch]

There is a separate mounting kit for the wall-mounted housing. It can be ordered from Endress+Hauser as an accessory. The following installation variants are possible:

- Panel-mounted installation
- Pipe mounting

Installation in control panel

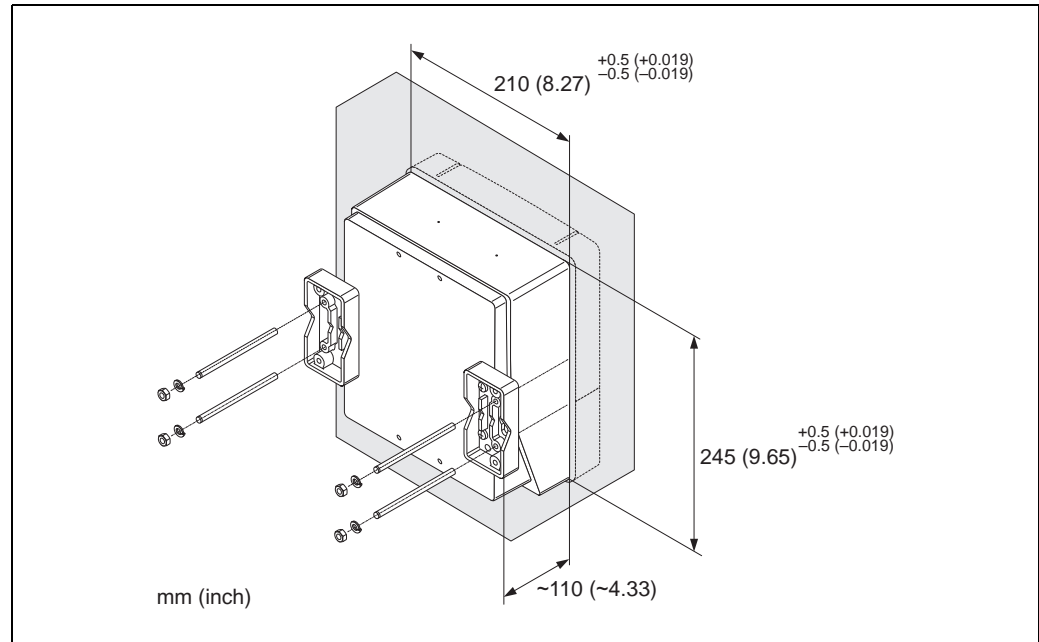

Pipe mounting

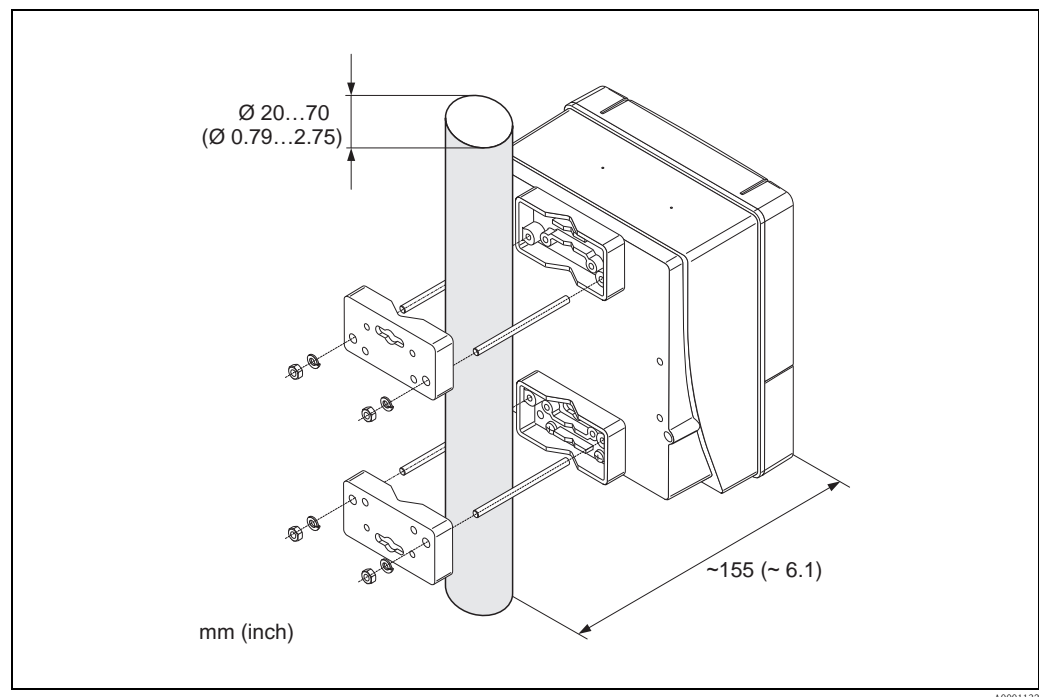

Sensor, remote version DN ≤ 300 (12")

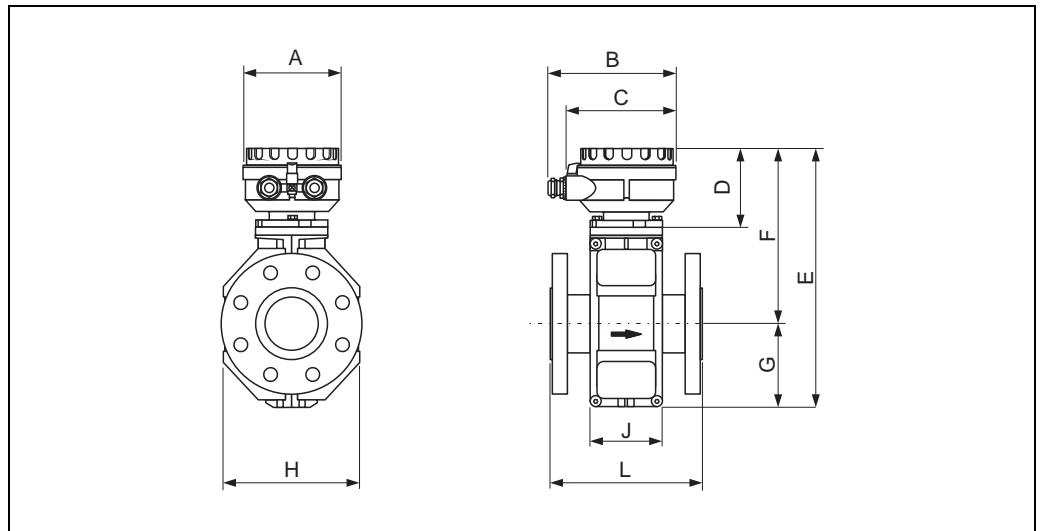

Dimensions (SI units)

DN EN (DIN) / JIS / AS ¹⁾	A	B	C	D	E	F	G	H	J	L
15	129	163	143	102	286	202	84	120	94	200
25					286	202	84	120	94	200
32					286	202	84	120	94	200
40					286	202	84	120	94	200
50					286	202	84	120	94	200
65					336	227	109	180	94	200
80					336	227	109	180	94	200
100					336	227	109	180	94	250
125					417	267	150	260	140	250
150					417	267	150	260	140	300
200					472	292	180	324	156	350
250					522	317	205	400	166	450
300					572	342	230	460	166	500

The fitting length (L) is always the same, regardless of the pressure rating.

¹⁾ Only DN 25 and DN 50 are available for flanges according to AS.

All dimensions in [mm]

Dimensions (US units)

DN ANSI	A	B	C	D	E	F	G	H	J	L
½"	5.08	6.42	5.63	4.02	11.3	7.95	3.31	4.72	3.70	7.87
1"					11.3	7.95	3.31	4.72	3.70	7.87
1½"					11.3	7.95	3.31	4.72	3.70	7.87
2"					11.3	7.95	3.31	4.72	3.70	7.87
3"					13.2	8.94	4.29	7.09	3.70	7.87
4"					13.2	8.94	4.29	7.09	3.70	9.84
6"					16.4	10.5	5.91	10.2	5.51	11.8
8"					18.6	11.5	7.08	12.8	6.14	13.8
10"					20.6	12.5	8.07	15.8	6.54	17.7
12"					22.5	13.5	9.06	18.1	6.54	19.7

The fitting length (L) is always the same, regardless of the pressure rating.
All dimensions in [inch]

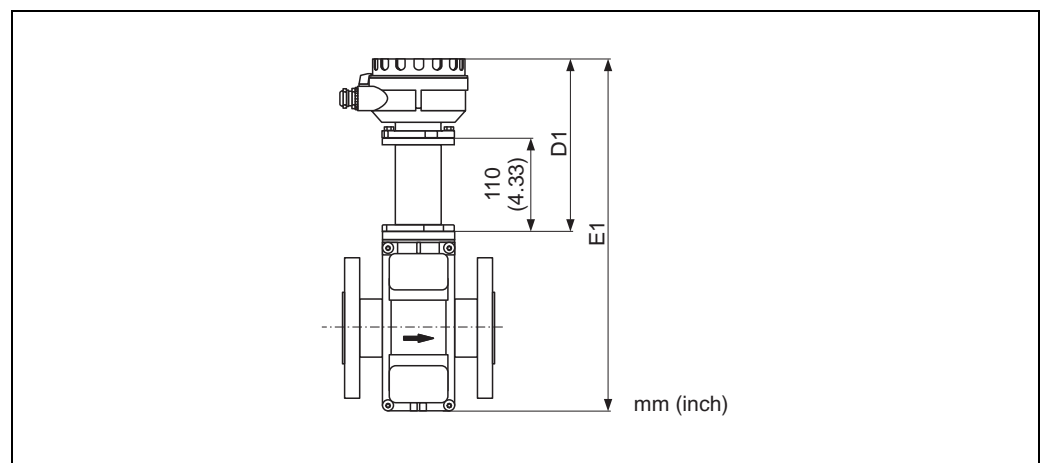
High temperature version DN ≤ 300 (12")

Measurement D1, E1 = Measurement D, E of the standard remote version plus 110 mm (4.33")

Sensor, remote version DN ≥ 300 (12")

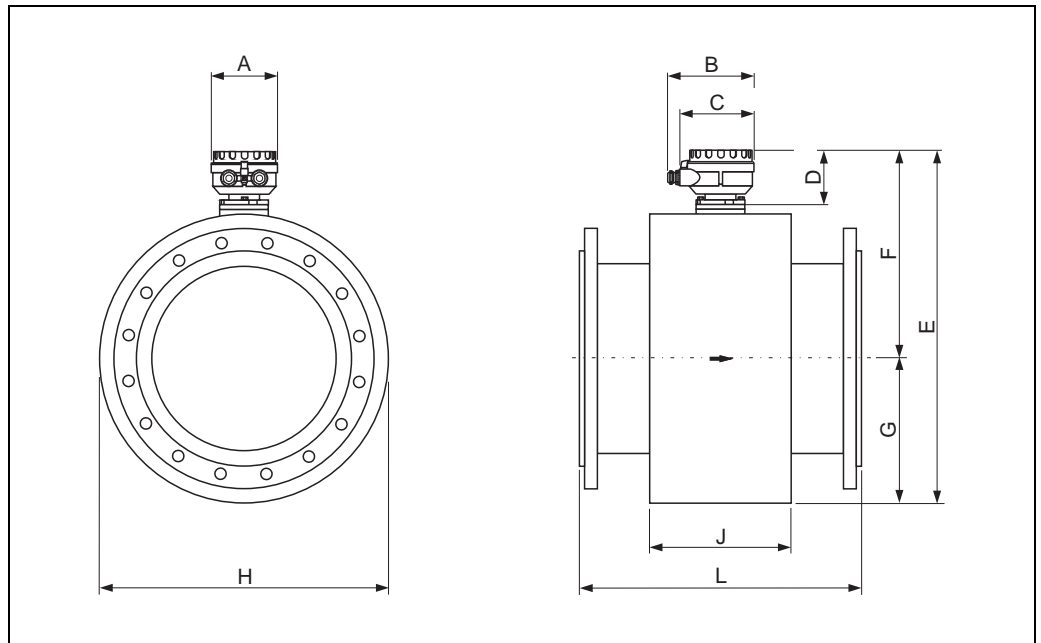

A0003220

Dimensions (SI units)

DN EN (DIN)	A	B	C	D	E	F	G	H	J	L
350	129	163	143	102	683.5	401.5	282.0	564	276	550
400					735.5	427.5	308.0	616	276	600
450					785.5	452.5	333.0	666	292	650
500					836.5	478.0	358.5	717	292	650
600					940.5	530.0	410.5	821	402	780

The fitting length (L) is always the same, regardless of the pressure rating.
All dimensions in [mm]

Dimensions (US units)

DN ANSI	A	B	C	D	E	F	G	H	J	L
14"	5.08	6.42	5.63	4.02	26.9	15.8	11.1	22.2	10.9	21.7
16"					29.0	16.8	12.1	24.3	10.9	23.6
18"					30.9	17.8	13.1	26.2	11.5	25.6
20"					32.9	18.8	14.1	28.2	11.5	25.6
24"					37.0	20.9	16.2	32.3	15.8	30.7

The fitting length (L) is always the same, regardless of the pressure rating.
All dimensions in [inch]

Compact version DN ≤ 300 (12")

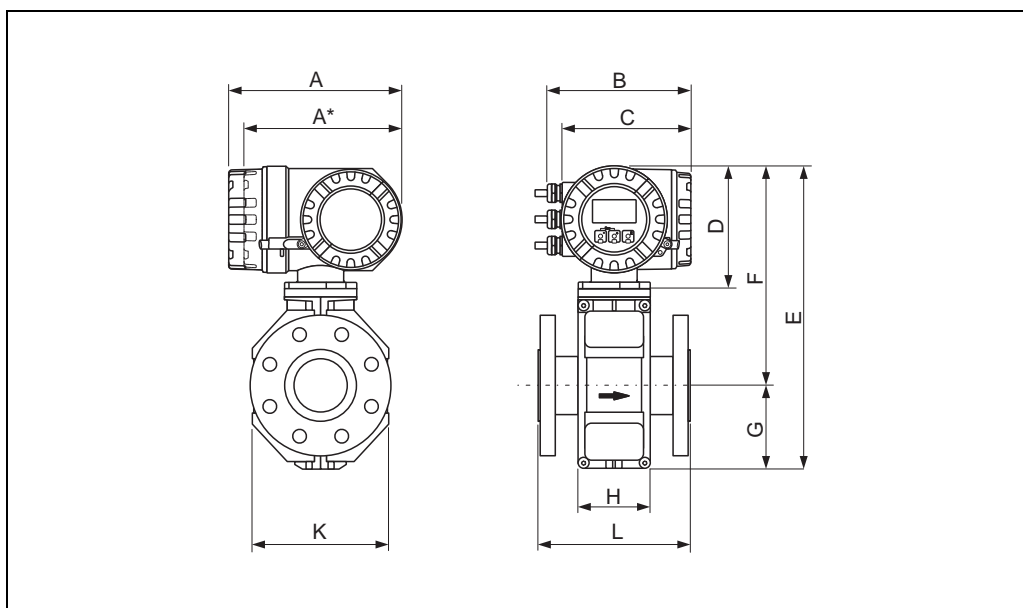

A0005423

Dimensions (SI units)

DN EN (DIN) / JIS / AS ¹⁾	A	A*	B	C	D	E	F	G	H	K	L
15	227	207	187	168	160	341	257	84	94	120	200
25						341	257	84	94	120	200
32						341	257	84	94	120	200
40						341	257	84	94	120	200
50						341	257	84	94	120	200
65						391	282	109	94	180	200
80						391	282	109	94	180	200
100						391	282	109	94	180	250
125						472	322	150	140	260	250
150						472	322	150	140	260	300
200						527	347	180	156	324	350
250						577	372	205	166	400	450
300						627	397	230	166	460	500

The fitting length (L) is always the same, regardless of the pressure rating.

¹⁾ Only DN 25 and DN 50 are available for flanges according to AS.

All dimensions in [mm]

Dimensions (US units)

DN ANSI	A	A*	B	C	D	E	F	G	H	K	L
½"	8.94	8.15	7.36	6.61	6.30	13.4	10.1	3.31	3.70	4.72	7.87
1"						13.4	10.1	3.31	3.70	4.72	7.87
1½"						13.4	10.1	3.31	3.70	4.72	7.87
2"						13.4	10.1	3.31	3.70	4.72	7.87
3"						15.4	11.1	4.29	3.70	7.09	7.87
4"						15.4	11.1	4.29	3.70	7.09	9.84
6"						18.6	12.7	5.91	5.51	10.2	11.8
8"						20.8	13.7	7.09	6.14	12.8	13.8
10"						22.7	14.7	8.07	6.54	15.8	17.7
12"						24.7	15.6	9.06	6.54	18.1	19.7

The fitting length (L) is always the same, regardless of the pressure rating.
All dimensions in [inch]

High temperature version DN ≤ 300 (12")

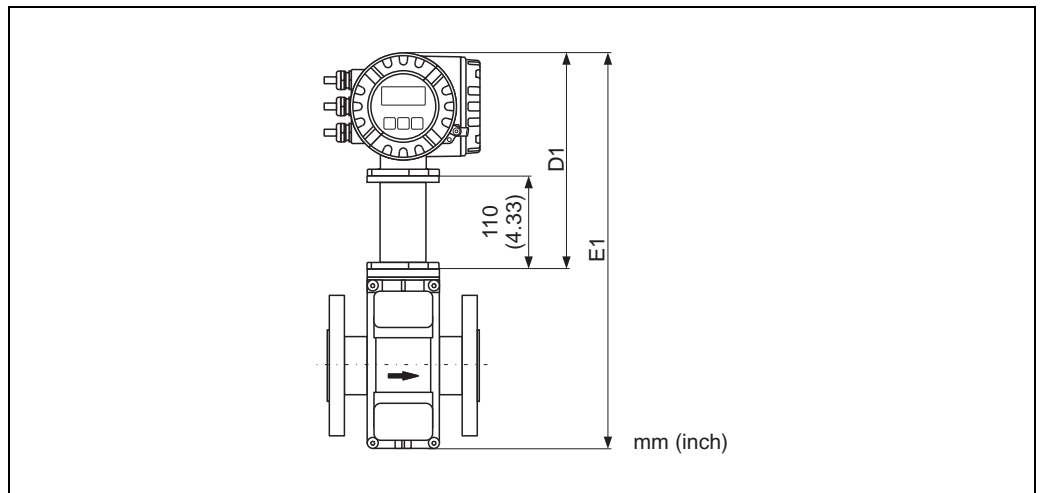

Measurement D1, E1 = Measurement D, E of the standard compact version plus 110 mm (4.33")

A0005529

Compact version DN ≥ 300 (12")

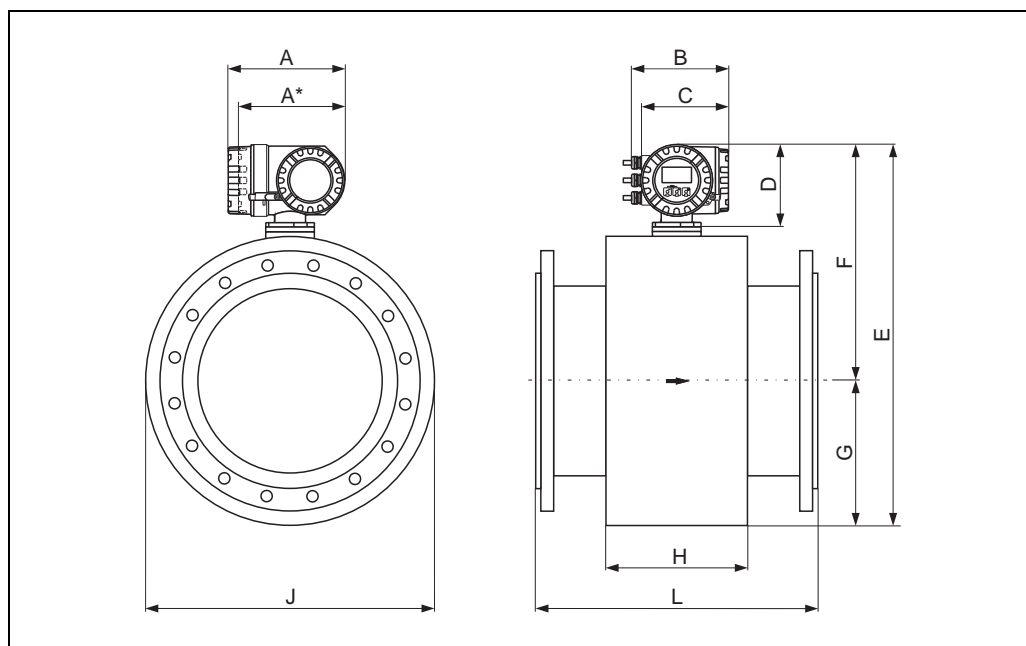

A0005424

Dimensions (SI units)

DN EN (DIN)	A	A*	B	C	D	E	F	G	H	J	L
350	227	207	187	168	160	738.5	456.5	282.0	564	276	550
400						790.5	482.5	308.0	616	276	600
450						840.5	507.5	333.0	666	292	650
500						891.5	533.0	358.5	717	292	650
600						995.5	585.0	410.5	821	402	780

The fitting length (L) is always the same, regardless of the pressure rating.
All dimensions in [mm]

Dimensions (US units)

DN ANSI	A	A*	B	C	D	E	F	G	H	J	L
14"	8.94	8.15	7.36	6.61	6.30	29.1	18.0	11.1	22.2	10.9	21.7
16"						31.1	19.0	12.1	24.3	10.9	23.6
18"						33.1	20.0	13.1	26.2	11.5	25.6
20"						35.1	21.0	14.1	28.2	11.5	25.6
24"						39.2	23.0	16.2	32.3	15.8	30.7

The fitting length (L) is always the same, regardless of the pressure rating.
All dimensions in [inch]

Ground disk for flange connections

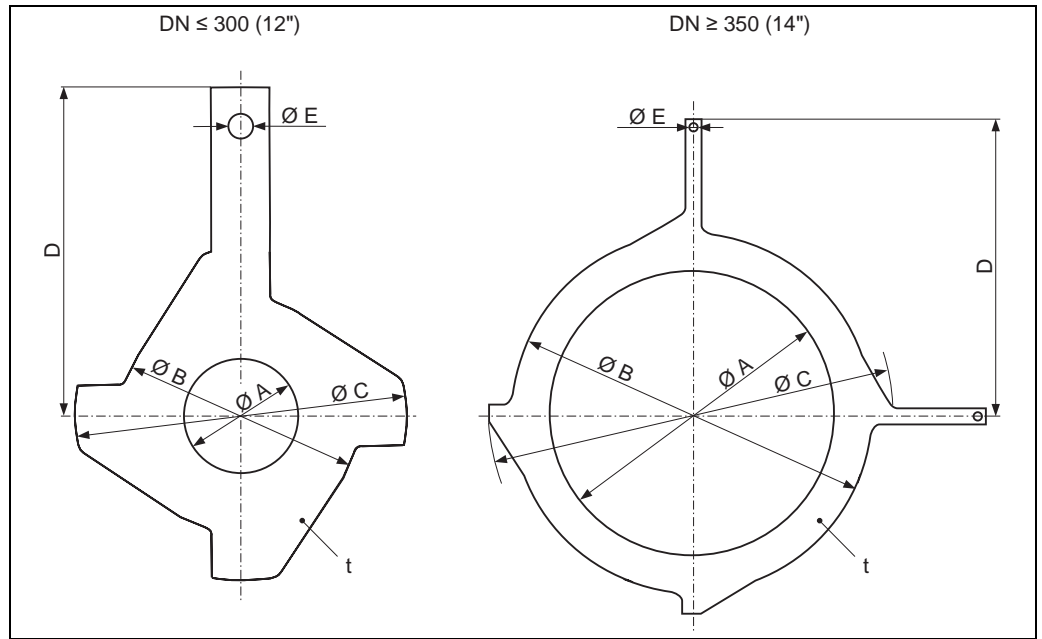

A0003221

Dimensions (SI units)

DN ¹⁾ EN (DIN) / JIS / AS ⁴⁾	A		B	C	D	E	t
	PTFE, PFA, PU, HR, NR _a ⁵⁾	NR _b ⁵⁾					
15	16	–	43	61.5	73	6.5	2
25	26	–	62	77.5	87.5		
32	35	–	80	87.5	94.5		
40	41	–	82	101	103		
50	52	–	101	115.5	108		
65	68	53	121	131.5	118		
80	80	66	131	154.5	135		
100	104	91.5	156	186.5	153		
125	130	117	187	206.5	160		
150	158	143.5	217	256	184		
200	206	192	267	288	205		
250	260	245	328	359	240		
300 ²⁾	312	294.5	375	413	273		
300 ³⁾	310	–	375	404	268		
350 ²⁾	343	323.5	433	479	365	9.0	
400 ²⁾	393	371	480	542	395		
450 ²⁾	439	420	538	583	417		
500 ²⁾	493	469	592	650	460		
600 ²⁾	593	566	693	766	522		

¹⁾ Ground disks at DN 15 to 250 can be used for all flange standards/nominal pressures available as standard.

²⁾ PN 10/16, CI 150

³⁾ PN 25, JIS 10K/20K

⁴⁾ Only DN 25 and DN 50 are available for flanges according to AS.

⁵⁾ Abbreviations (lining): PU = Polyurethane, HR = Hard rubber, NR_a = Natural rubber thin, NR_b = Natural rubber thick
All dimensions in [mm]

Dimensions (US units)

DN ¹⁾ ANSI	A		B	C	D	E	t
	PTFE, PFA, PU, HR, NR _a ²⁾	NR _b ²⁾					
½"	0.63	–	1.69	2.42	2.87	0.26	0.08
1"	1.02	–	2.44	3.05	3.44		
1½"	1.61	–	3.23	3.98	4.06		
2"	2.05	–	3.98	4.55	4.25		
3"	3.15	2.60	5.16	6.08	5.31		
4"	4.09	3.60	6.14	7.34	6.02		
6"	6.22	5.65	8.54	10.08	7.24		
8"	8.11	7.56	10.5	11.3	8.07		
10"	10.2	9.65	12.9	14.1	9.45		
12"	12.3	11.6	14.8	16.3	10.8		
14"	13.5	12.7	17.1	18.9	14.4		
16"	15.45	14.6	18.9	21.3	15.6		
18"	17.3	16.5	21.2	23.0	16.4		
20"	19.4	18.5	23.3	25.6	18.1		
24"	23.4	22.3	27.3	30.1	20.6		

¹⁾ Ground disks can be used for all pressure ratings.

²⁾ Abbreviations (lining): PU = Polyurethane, HR = Hard rubber, NR_a = Natural rubber thin, NR_b = Natural rubber thick
All dimensions in [inch]

Weight

Weight in [kg]

Nominal diameter		Compact version			Remote version (without cable)				Transmitter (Wall-mount housing)
		EN (DIN) / AS*	JIS	ANSI	Sensor				
[mm]	[inch]				EN (DIN) / AS*	JIS	ANSI		
15	½"	PN 40	6.5	6.5	6.5	PN 40	4.5	4.5	4.5
25	1"		7.3	7.3	7.3		5.3	5.3	5.3
32	-		8.0	7.3	-		6.0	5.3	-
40	1½"		9.4	8.3	9.4		7.4	6.3	7.4
50	2"		10.6	9.3	10.6		8.6	7.3	8.6
65	-	PN 16	12.0	11.1	-	PN 16	10.0	9.1	-
80	3"		14.0	10K 12.5	14.0		12.0	10K 10.5	12.0
100	4"		16.0	14.7	16.0		14.0	12.7	14.0
125	-		21.5	21.0	-		19.5	19.0	-
150	6"		25.5	24.5	Class 150 25.5		23.5	22.5	Class 150 23.5
200	8"	PN 10	45	41.9	45	PN 10	43	39.9	43
250	10"		65	69.4	75		63	67.4	73
300	12"		70	72.3	110		68	70.3	108
350	14"		115		175		113		173
400	16"		135		205		133		203
450	18"	175		255	173		253		
500	20"	175		285	173		283		
600	24"	235		405	233		403		

Transmitter (Compact version): 3.4 kg

High temperature version: +1.5 kg

(Weight data valid for standard pressure ratings and without packaging material)

* Only DN 25 and DN 50 are available for flanges according to AS.

Weight in [lbs]

Nominal diameter		Compact version			Remote version (without cable)				Transmitter (Wall-mount housing)	
		EN (DIN) / AS*	JIS	ANSI	Sensor					
[mm]	[inch]				EN (DIN) / AS*	JIS	ANSI			
15	½"	PN 40	14	14	14	PN 40	10	10	10	13
25	1"		16	16	16		12	12	12	
32	–		18	16	–		13	12	–	
40	1½"		21	18	21		16	14	16	
50	2"	23	21	23	19	16	19			
65	–	PN 16	26	24	–	PN 16	22	20	–	
80	3"		31	28	31		26	23	26	
100	4"		35	32	35		31	28	31	
125	–		47	46	–		43	42	–	
150	6"	56	54	56	52	50	52			
200	8"	PN 10	99	92	99	PN 10	95	88	95	
250	10"		143	153	165		139	149	161	
300	12"		154	159	243		150	155	238	
350	14"		254		386		249		381	
400	16"	298		452	293		448			
450	18"	386		562	381		558			
500	20"	386		628	381		624			
600	24"	518		893	514		889			

Transmitter (Compact version): 3.4 kg

High temperature version: +1.5 kg

(Weight data valid for standard pressure ratings and without packaging material)

* Only DN 25 and DN 50 are available for flanges according to AS.

Materials

Transmitter housing:

- Compact and remote version: Powder-coated die-cast aluminum

Sensor housing:

- DN 15 to 300 (½ to 12"): Powder-coated die-cast aluminum
- DN 350 to 600 (14 to 24"): Painted steel

Measuring tube:

- DN < 350 (14"): Stainless steel 1.4301/304 or 1.4306/304L. For flanges of carbon steel with Al/Zn protective coating.
- DN > 300 (12"): Stainless steel 1.4301/304. For flanges of carbon steel with protective paint finish.

Flange:

- EN 1092-1 (DIN 2501): 316L / 1.4571 (SS 316Ti); RSt37-2 (S235JRG2) / C22 / FE 410W B (DN < 350 (14"): with Al/Zn protective coating; DN > 300 (12") with protective paint finish)
- ANSI: A105; F316L (DN < 350 (14") with Al/Zn protective coating; DN > 300 (12") with protective paint finish)
- JIS: RSt37-2 (S235JRG2) / H11 / 1.0425 / 316L (DN < 350 (14") with Al/Zn protective coating; DN > 300 (12") with protective paint finish)
- AS 2129:
 - DN 25 (1"): A105 or RSt37-2 (S235JRG2), with Al/Zn protective coating
 - DN 50 (2"): A105 or St44-2 (S275JR), with Al/Zn protective coating
- AS 4087:
 - DN 50 (2"): A105 or St44-2 (S275JR), with Al/Zn protective coating

Ground disks: 1.4435/316L or Alloy C-22

Electrodes:

- 1.4435/316L, platinum, Alloy C-22, tantalum, titanium Gr. 2, tungsten carbide coating (for electrodes made from 1.4435)
- 1.4310/302 (for brush electrodes), Duplex 1.4462, Alloy X750 (for brush electrodes)

Seals: according to DIN EN 1514-1

Material load diagrams

Caution!

The following diagrams contain material load curves (reference curves) for various process connections relating to the fluid temperature. But the maximal permissible fluid temperature always depends on the lining material of the sensor and/or the sealing material.

Flange connection to EN 1092-1 (DIN 2501)

Flange material: RSt37-2 (S235JRG2) / C22 / Fe 410W B

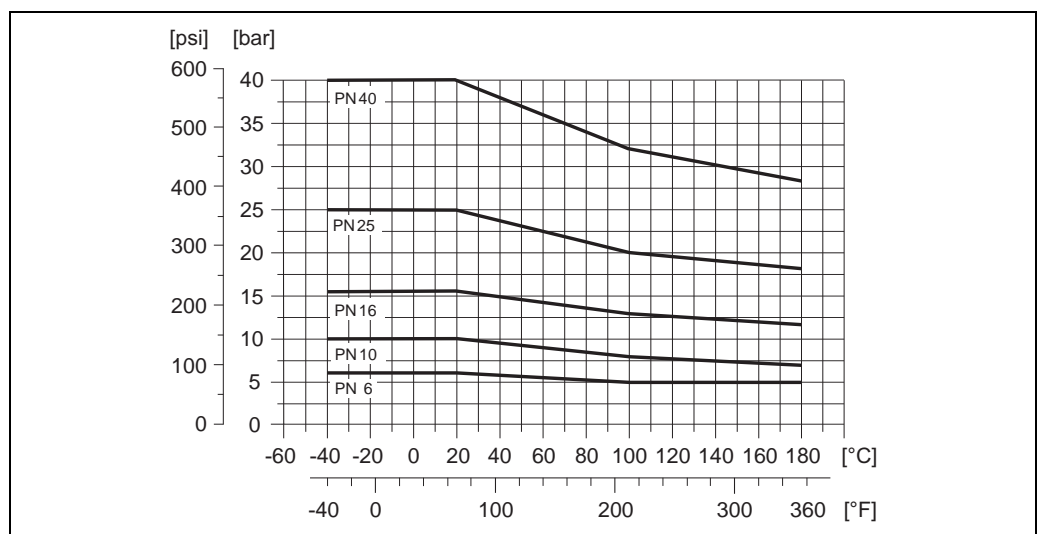

A0005594

Flange connection to EN 1092-1 (DIN 2501)

Flange material: 316L / 1.4571

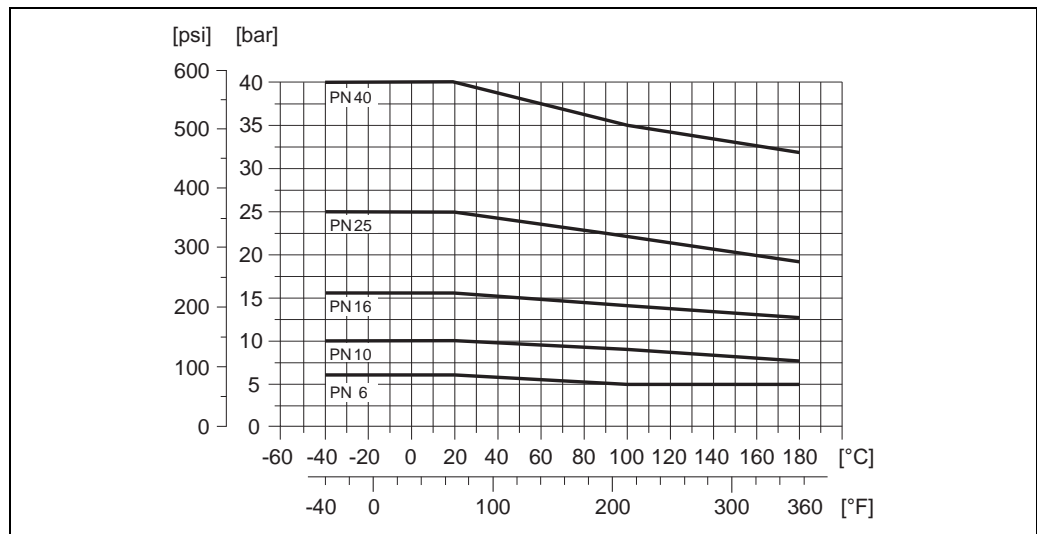

A0005304

Flange connection to ANSI B16.5

Flange material: A105

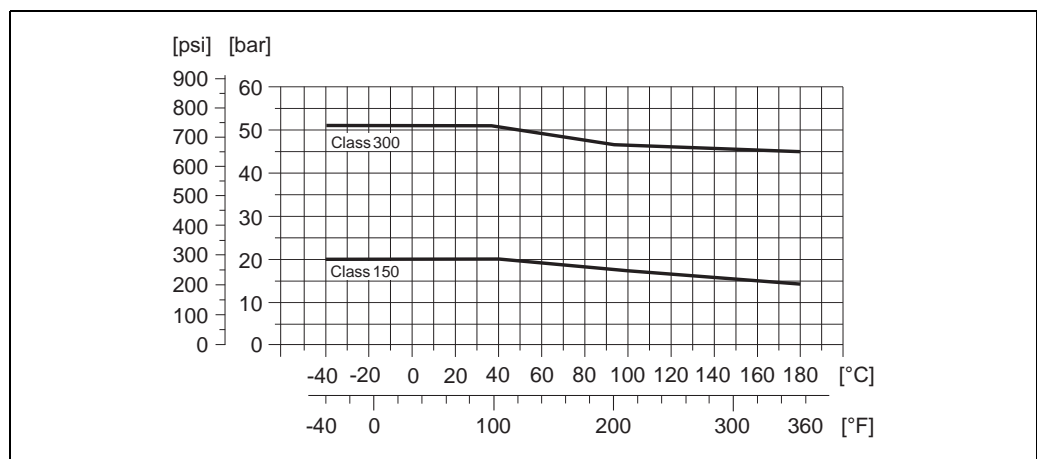

A0003226

Flange connection to ANSI B16.5

Flange material: F316L

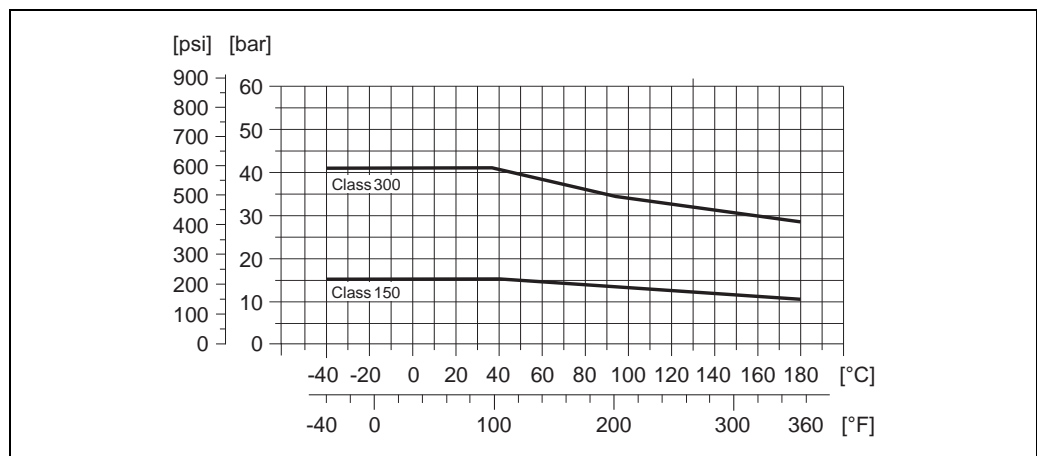

A0005307

Flange connection to JIS B2220

Flange material: RSt37-2 (S235JRG2) / H II / 1.0425

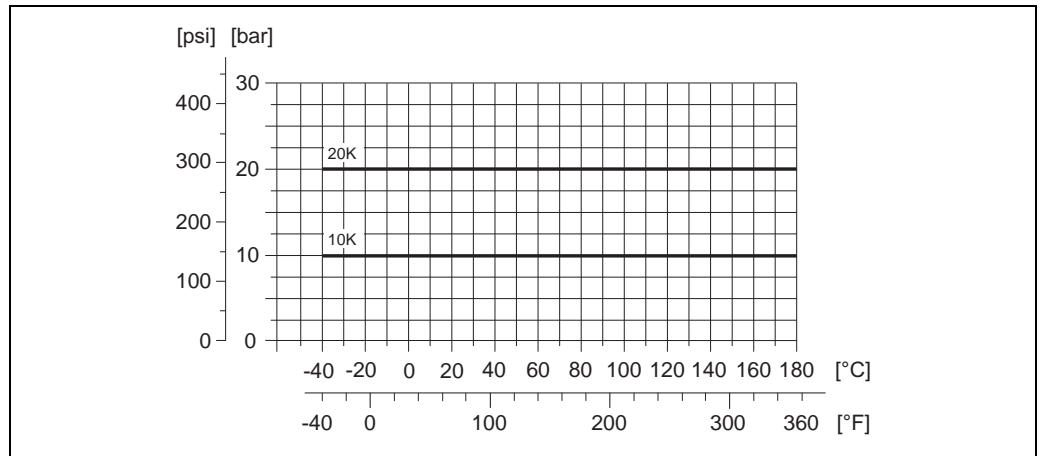

A0003228

Flange connection to AS 2129 Table E or AS 4087 PN 16

Flange material: A105 / RSt37-2 (S235JRG2) / St44-2 (S275JR)

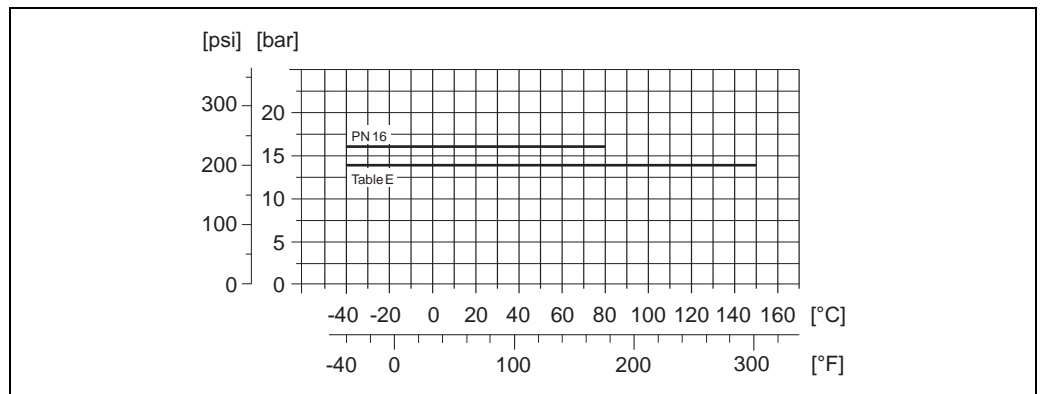

A0005595

Fitted electrodes

Comes as standard:

- 2 measuring electrodes for signal detection
- 1 EPD electrode for empty pipe detection
- 1 Reference electrode for potential equalization

Optionally available for measuring electrodes made of platinum:

- 1 EPD electrode for empty pipe detection
- 1 Reference electrode for potential equalization

For measuring tube with natural rubber lining in combination with brush electrodes:

- 2 brush electrodes for signal detection

Process connections

Flange connection:

- EN 1092-1 (DIN 2501)
 - DN < 300 (12"): Form A
 - DN > 300 (12"): Form B
 - DN 65 (2½") PN 16 and DN 600 (24") PN 16 exclusively according to EN 1092-1
- ANSI
- JIS
- AS

Surface roughness

- Lining with PFA: ≤ 0.4 µm (16 µin)
- Electrodes: 0.3 to 0.5 µm (12 to 20 µin)

All data relate to wetted parts.

Human interface

Display elements

- Liquid-crystal display: illuminated, four lines with 16 characters per line
- Custom configurations for presenting different measured values and status variables
- 3 totalizers
- At ambient temperatures below -20 °C (-4 °F), the readability of the display may be impaired.

Operating elements

- Onsite operation with three optical sensor keys (□/+/E)
- Application-specific Quick Setup menus for straightforward commissioning

Language groups

Language groups available for operation in different countries:

- Western Europe and America (WEA):
English, German, Spanish, Italian, French, Dutch, Portuguese
- Eastern Europe/Scandinavia (EES):
English, Russian, Polish, Norwegian, Finnish, Swedish, Czech
- South and East Asia (SEA):
English, Japanese, Indonesian
- China (CN):
English, Chinese



Note!

You can change the language group via the operating program "FieldCare".

Language groups

Remote operation via HART, PROFIBUS DP/PA, FOUNDATION Fieldbus

Certificates and approvals

CE mark	The measuring system described in these Operating Instructions therefore complies with the legal requirements of the EU Directives. Endress+Hauser confirms this by affixing the CE mark to it and by issuing the CE declaration of conformity.
C-tick mark	The measuring system meets the EMC requirements of the "Australian Communications and Media Authority (ACMA)".
Ex certification	Information on the currently available Ex-rated versions (ATEX, FM, CSA etc.) is available on request from your Endress+Hauser sales outlet. All information relevant to explosion protection is available in separate documents that you can order as necessary.
Sanitary compatibility	No applicable approvals or certification
Pressure measuring device approval	<p>The measuring devices can be ordered with or without PED (Pressure Equipment Directive). If a device with PED is required, this must be ordered explicitly. For devices with nominal diameters less than or equal to DN 25 (1"), this is neither possible nor necessary.</p> <ul style="list-style-type: none"> ■ With the identification PED/G1/III on the sensor nameplate, Endress+Hauser confirms conformity with the "Basic safety requirements" of Appendix I of the Pressure Equipment Directive 97/23/EC. ■ Devices with this identification (with PED) are suitable for the following types of fluid: <ul style="list-style-type: none"> – Fluids of Group 1 and 2 with a steam pressure of greater or less than 0.5 bar (7.3 psi) – Unstable gases ■ Devices without this identification (without PED) are designed and manufactured according to good engineering practice. They correspond to the requirements of Art. 3, Section 3 of the Pressure Equipment Directive 97/23/EC. Their application is illustrated in Diagrams 6 to 9 in Appendix II of the Pressure Equipment Directive 97/23/EC.
FOUNDATION Fieldbus certification	<p>The flow device has successfully passed all the test procedures carried out and is certified and registered by the Fieldbus Foundation. The device thus meets all the requirements of the following specifications:</p> <ul style="list-style-type: none"> ■ Certified to FOUNDATION Fieldbus Specification ■ The device meets all the specifications of the FOUNDATION Fieldbus H1 ■ Interoperability Test Kit (ITK), revision status 5.1 (device certification number: on request) ■ The device can also be operated with certified devices of other manufacturers ■ Physical Layer Conformance Test of the Fieldbus Foundation
PROFIBUS DP/PA certification	<p>The flowmeter has successfully passed all the test procedures carried out and is certified and registered by the PNO (PROFIBUS User Organization). The device thus meets all the requirements of the following specifications:</p> <ul style="list-style-type: none"> ■ Certified in accordance with PROFIBUS Profile Version 3.0 (device certification number: available on request) ■ The measuring device can also be operated with certified devices of other manufacturers (interoperability)
Other standards, guidelines	<ul style="list-style-type: none"> ■ EN 60529 Degrees of protection by housing (IP code) ■ EN 61010-1 Protection Measures for Electrical Equipment for Measurement, Control, Regulation and Laboratory Procedures ■ IEC/EN 61326 "Emission in accordance with requirements for class A". Electromagnetic compatibility (EMC requirements). ■ ANSI/ISA-S82.01 Safety Standard for Electrical and Electronic Test, Measuring, Controlling and related Equipment - General Requirements. Pollution degree 2, Installation Category II. ■ CAN/CSA-C22.2 (No. 1010.1-92) Safety requirements for Electrical Equipment for Measurement and Control and Laboratory Use. Pollution degree 2, Installation Category I. ■ NAMUR NE 21 Electromagnetic compatibility (EMC) of industrial process and laboratory control equipment.

- NAMUR NE 43
Standardization of the signal level for the breakdown information of digital transmitters with analog output signal.
- NAMUR NE 53
Software of field devices and signal-processing devices with digital electronics.

Ordering information



Note!

Endress+Hauser reserves the right to change or modify product, specifications, and ordering information at any time without notice. Please consult Endress+Hauser or your local representative for the most recent information.

Accessories

Various accessories are available for the transmitter and the sensor. These can be ordered separately from Endress+Hauser.



Note!

For detailed information on specific order codes, please contact the Endress+Hauser service organization.

Supplementary documentation

- Flow Measurement (FA005D)
- Technical Information
 - Promag 55H (TI00096D)
- Operating Instructions/Description of Device Functions
 - Promag 55 HART (BA00119D/BA00120D)
 - Promag 55 PROFIBUS DP/PA (BA00124D/BA00125D)
 - Promag 55 FOUNDATION Fieldbus (BA00126D/BA00127D)
- Supplementary documentation on Ex-ratings: ATEX, FM, CSA

Registered trademarks

HART®

Registered trademark of HART Communication Foundation, Austin, USA

PROFIBUS®

Registered trademark of the PROFIBUS User Organisation, Karlsruhe, Germany

FOUNDATION™ Fieldbus

Registered trademark of the Fieldbus Foundation, Austin, USA

HistoROM™, S-DAT®, T-DAT®, F-CHIP®, FieldCare®, Fieldcheck®, Applicator®

Registered or registration-pending trademarks of Endress+Hauser Flowtec AG, Reinach, CH

Instruments International

Endress+Hauser
Instruments International AG
Kaegenstrasse 2
4153 Reinach
Switzerland

Tel. +41 61 715 81 00
Fax +41 61 715 25 00
www.endress.com
info@ii.endress.com

Endress+Hauser 
People for Process Automation