

# Fulflo

## HYDRAULIC BYPASS RELIEF VALVES



*“The Quiet Ones”*

CHATTER FREE PERFORMANCE

MADE IN THE USA

# FULFLO SPECIALTIES COMPANY...

**OUR MISSION STATEMENT:** *Fulflo Specialties will strive to be the world leader in the valve manufacturing industry. Our mission is to achieve and sustain through continual improvement, the highest quality of product and services. Fulflo will ensure that every employee, vendor, and subcontractor share a common goal of quality and reliability at an affordable price.*

## Pioneers in Fluid Power

Established in 1912, FULFLO was incorporated in 1933 under its present name and trademark. Patents for the original guided piston, direct-acting relief valve were obtained in 1935, coincident with the onset of fluid power systems. The need for providing large flows without excessive bulk was subsequently met by the pilot-valve-controlled relief valve, a patent on which was issued to FULFLO in 1943 (U.S. Patent No. 2,333,522).

FULFLO is located in Blanchester, Ohio just 30 miles northeast of Cincinnati, close to some of the state's

largest manufacturing centers. Blanchester is served by air from Greater Cincinnati Airport and alternately from Dayton Municipal Airport.

From Cincinnati, travel Interstate 71 north to Interstate 275, east to US 28 and northeast to Blanchester.

From Dayton, travel Interstate 75 south to Route 123 and southeast to Blanchester.

If you plan to visit FULFLO, advise us of your itinerary and we will be happy to assist with transportation and hotel arrangements.

## TERMS AND CONDITIONS

**Product Information.** Please include complete product data as described in the catalog. **Note:** All valves will be set midrange pressure of the spring, unless otherwise specified.

**Instructions.** All requirements specific to a customer's order must be stated on original purchase order. This includes, but is not limited to, tagging, markings, documentation, packaging, ship via collect account numbers, etc... All requirements regarding a purchase order should be verified by the faxed acknowledgment.

**Shipping Information.** Please include purchaser's name, complete address and requested routing. Product may be shipped via Ground, insured parcel post or commercial motor freight.

**Guarantee.** Fulflo products are guaranteed against defects in workmanship or material for one year after date of shipment. Fulflo is not liable for any damages resulting from misuse or misapplication of its product.

**Specifications.** For continued improvement of our product line, we reserve the right to change product specifications without prior notice.

**Cancellations.** Charges are based on work accomplished prior to the receipt of cancellation.

**Returned Material.** An RGA (Return Goods Authorization) Number **must** be issued before returning any valves, parts not accepted.

**Restocking.** Product returned is subject to a restocking charge. Restocking fee is 25% of List Price on standard product line. Special products are subject to additional charges.

**Prices.** F.O.B. Blanchester, Ohio. Prices are subject to change without notice.

**Terms.** Net 30 days to buyers with approved credit: all other shipments are C.O.D., MC / or VISA.

**Invoicing.** Buyers will be invoiced by Fulflo Specialties, 459 E. Fancy Street, Blanchester, Ohio 45107.

**Delivery.** Deliveries are scheduled after receipt of orders which should include all required technical information. Shipping dates are **estimated** based on conditions prevailing at the time of quotation, but are not guaranteed. Fulflo shall not be liable for delays in delivery due to causes beyond its reasonable control. Fulflo shall not be liable for any special or consequential damages caused by or resulting from delay, failure to manufacture or deliver.

**Minimum Order.** Minimum order charge required is \$40.00.

**Expediting Fee.** Orders may be subject to a 20% net expediting fee.

**Change Order Fee.** There is a \$25.00 change order fee, per order.

DUE TO ENGINEERING UPGRADING, THE DIMENSIONS AND SPECIFICATIONS ARE SUBJECT TO CHANGE, BUT ARE CORRECT HERE AT TIME OF PRINTING.



# CONTENTS

<b>General Information / Terms and Conditions</b> .....	2
---	---

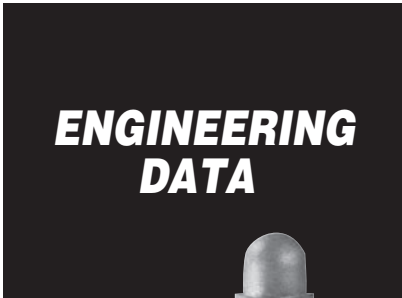

## ENGINEERING DATA

<b>ENGINEERING DATA</b>	
Valve Design Characteristics .....	4
Valve Sizing-Use of Performance Charts .....	4
Pipe Sizing-Use of the Nomograph .....	5
Application Diagrams .....	6
Spring Material & Temperature Chart .....	7
Connections .....	8
SAE O-Ring Boss .....	8
Socket Weld .....	9
Standard Materials .....	9
ASTM/ASME Specifications .....	9
Material Codes .....	9
O-Ring and Pad Materials .....	9
Max Temp. Max Pressure .....	9
Orifice Area & Piston/Body Tolerances .....	9
Flange and Drilling Dimensions .....	10



## V-SERIES VALVES

<b>V-SERIES VALVES</b>	
Application and Installation .....	11
Valve Setting – Maintenance – Disassembly .....	12
Assembly Number Identification Chart .....	13
Standard Spring Pressure Range Chart .....	13
Dimensions and Parts List .....	14-17
VJ, VB, VS, VSS, VJ-SP .....	14
VJF, VBF, VSF, VSSF, VJF-SP .....	15
HVJ, HVB, HVS, HVSS .....	16
HVJ-P, HVB-P, HVS-P, HVSS-P .....	16
HVJF, HVBF, HVSF, HVSSF .....	17
HVJF-P, HVBF-P, HVSF-P, HVSSF-P .....	17
Performance Charts .....	18-19



## FV-SERIES VALVES

<b>FV-SERIES VALVES</b>	
Application and Installation .....	20
Valve Setting – Maintenance – Disassembly .....	21
Assembly Number Identification Chart .....	22
Standard Spring Pressure Range Chart .....	22
Dimensions and Parts List .....	23-24
FVJ, FVB, FVS, FVSS .....	23
FVJF, FVBF, FVSF, FVSSF .....	24
Performance Charts .....	25-26



## OV-SERIES VALVES

<b>OV-SERIES VALVES</b>	
Application and Installation .....	27
Valve Setting – Maintenance – Disassembly .....	28
Assembly Number Identification Chart .....	29
Standard Spring Pressure Range Chart .....	29
Dimensions and Parts List .....	30-31
OVJ, OVB, OVS, OVSS .....	30
OVJF, OVBF, OVSF, OVSSF .....	31
Performance Charts .....	32-33



## A-SERIES VALVES

<b>A-SERIES VALVES</b>	
Application and Installation .....	34
Valve Setting – Maintenance – Disassembly .....	35
Model Number and Ordering Information .....	36
Standard Spring Pressure Range Chart .....	36
Direct Acting Valves .....	37
Dimensions and Parts List .....	37-38
AAD, ACD, ASSD .....	37
AADF, ACDF, ASSDF .....	38
Performance Charts .....	39
Internal Pilot Operated Valves .....	40
Disassembly .....	40
Dimensions and Parts List .....	41-42
AAP, ACP, ASSP .....	41
AAPF, ACPF, ASSPF .....	42
Performance Charts .....	43



## SVB SERIES VALVES

<b>SVB-SERIES VALVES (Underwriter Listed)</b>	
Application and Installation .....	44
Maintenance – Disassembly .....	45
Valve Setting .....	46
Model Number and Ordering Information .....	46
Standard Spring Pressure Range Chart .....	46
Dimensions and Parts List .....	47
Performance Charts .....	49-49
Notes .....	50



## APPLICATIONS

<b>APPLICATIONS</b>	
Typical Applications & Valve Definitions .....	51



## SPECIALTY VALVES

Please contact Fulflo directly for special applications. We can engineer special or modified valves to meet your application.

# VALVE SIZING...Use of Performance Charts

## FULFLO GUIDED PISTON VALVES

The trademark FULFLO expresses the basic principle that the relief valve must have flow capacity equal to that of the pipe lines to which it is connected. The sliding piston concept and internal design contours of FULFLO valves provide unique flow and stability characteristics for reliable performance without chatter.

FULFLO valves are designed to operate reliably at pressures as low as 2 PSI and as high as 1000 PSI. The FULFLO valve reduces velocities through all but the controlling interface of the valve thereby minimizing system power loss.

Unlike ordinary direct acting relief valves, FULFLO guided piston valves are less responsive to transient pressure surges thereby eliminating the tendency to pound, squeal or chatter. Quiet, stable, efficient performance is assured in both load regulation and system protection applications.

FULFLO valves operate effectively with all types of liquids in the full range of viscosities including hydraulic oils, water, solvents and chemicals.

FULFLO valves are not designed to be positive shut off, and will pass a minimal amount of leakage before the set pressure.

FULFLO valves are NOT designed for use with air, gas or steam.

Since the FULFLO relief valve is a flow-modulating device, pressure flow characteristics are completely different from spring loaded poppet or ball check valves. Both types remain substantially tight up to *cracking pressure*. When this pressure is exceeded, the "conventional" valve pops open with a pressure drop at very low flow and an exponential pressure rise as the flow increases.

In contrast the FULFLO valve causes a pressure rise, *over-pressure*, as soon as flow starts; pressure increases almost proportionally with flow. Springs and areas on FULFLO valves are carefully designed to minimize this over-pressure.

Both pressures are important in sizing a valve. *Cracking pressure* must be selected high enough to permit system operation at its maximum rated pressure and flow. *Over-pressure* is limited by the system's capability to withstand the additional pressure and the motor's ability to sustain the pump output at the increased pressure for the required time interval.

The over-pressure to produce a certain flow is a function of valve size and spring constant and can be determined with the aid of the over-pressure charts given for the different valve sizes. The valve performance charts are based on tests made with oil of 150 SSU viscosity at 100° F and may be used with reasonable accuracy within the conventional range of oil viscosities from 30 to 500 SSU. For operation with high viscosity fluids, consult FULFLO's engineering department.

In sizing a valve, the first attempt should be to select a

valve equal in size to the pipe to which it is connected. A larger or smaller valve may be used to suit individual requirements, depending on the permissible amount of over-pressure. Assume we have selected a 3/4" valve for 17 GPM flow and a cracking pressure of 325 PSI. By referring to the pressure range chart, we find that we may use either a "YS" or a "ZS" spring.

Assuming a "YS" spring, draw a line horizontally at 17 GPM in the 3/4" valve chart, to intersect the slanted line marked "YS" and drop a vertical line to the over-pressure scale to read an over-pressure of 44 PSI. The 17 GPM will be discharged at a pressure of 325 + 44 or 369 PSI. The percentage of over-pressure would be  $44/325 \times 100$  or 13.5%.

If a "ZS" spring is used, extend the horizontal line to the "ZS" slope and the over-pressure is 70 PSI. The pressure to pass 17 GPM would be 325 + 70 or 395 PSI and the over-pressure would be 21.5%. If the over-pressure is higher than desired for the particular application, the procedure may be repeated for the next larger size valve.

In some cases, maximum flow through a valve at a given pressure is specified. To determine the cracking pressure, assume a 3/4" valve is to pass 12 GPM at 50 PSI. A horizontal line drawn from the 12 GPM capacity to the intersection with the "WS" spring line results in an over-pressure of 14 PSI, therefore the cracking pressure must be 50 - 14 or 36 PSI, and the percentage of over-pressure of only 9 PSI, but the cracking pressure would be  $14/36 \times 100$  or 38.8%. The use of a "US" spring would produce an over pressure of only 9 PSI but the cracking pressure would then be 50 - 9 or 41 PSI, which would exceed the rating of the "US" spring.

For sizing valves for higher viscosity than 500 SSU, the following formula is used:

$$4\sqrt{\frac{V_2}{V_1}} \times \text{area of valve for 150 SSU}$$

$$V_1 = 150 \text{ SSU}$$

$$V_2 = \text{higher viscosity}$$

Assume we have the following application,

$$\text{GPM} = 10$$

$$\text{Viscosity} = 12,000 \text{ SSU}$$

Normally for 10 GPM a 1/2" valve would be used. Referring to the orifice area chart on page 9, to find the area of a 1/2" valve. The area is .305.

$$4\sqrt{\frac{12000}{150}} = 4\sqrt{80} = 2.99$$

$2.99 \times .305 = .9120$  area needed to pass 10 GPM

Again referring to the orifice area chart, we find that the area of 1 1/4" valve is 1.224. Therefore a 1 1/4" valve would be used. To find the over-pressure refer to the performance chart for a 1 1/4" valve.

Performance charts based on actual test results are available on request. For additional information contact THE FULFLO SPECIALTIES CO.

# PIPE SIZING...Use of the Nomograph

The flow velocity, which must first be determined, is dependent on the viscosity of the fluid and the permissible flow resistance in the piping. Lower velocities are for higher viscosity fluids and/or lower pressure drops; higher velocities are for less viscous fluids and cases where higher pressure drops can be tolerated. In all cases, allowable suction velocities are much lower and the lowest velocities should be used for the more viscous fluids and/or higher suction lifts.

Suction velocities are much more critical than discharge velocities. Too high a discharge velocity may only result in excessive power loss but an excessive suction velocity may make the system inoperative or cause damage to the pump and system.

After the velocity has been selected, the nomograph chart is used to determine the inside diameter of the pipe at a given flow rate. For example, assume a flow of 17 gpm and a velocity of 12 fps for the discharge pipe is required. Draw a line from the 12 fps point on the velocity scale through the 17 gpm point on the flow rate scale and the extended line intersects the pipe inside diameter scale at 0.76 inches. This inside diameter applies to either pipe or tubing.

The correct pipe or tube size also depends on the pressure it must carry. The conversion chart for pipe sizes and schedules facilitates this section.

Note the different weights or piping are grouped under various schedule numbers. Approximate pressure for each schedule number may be computed from the formula.

$$\text{Pressure} = \frac{S}{1000} \times \text{schedule number}$$

S is the permissible stress to which the pipe is subjected. Thus, for a stress of 10,000 psi, the allowable pressure is equal to ten times the schedule number. Higher pressures may be carried if higher stresses are allowed.

In the example, a schedule 40 pipe is more than adequate for 250 psi. Twice the wall thickness of a 3/4" schedule 40 pipe of 0.226 or 0.976". Since the actual outside diameter of a 3/4" schedule 40 pipe is 1.05", the selection of a 3/4" pipe is adequate.

A 3/4" Fulflo relief valve should be selected. Operational characteristics of this valve, that is cracking pressure and overpressure, may be determined from the performance chart precisely in the manner explained in the example. The maximum discharge pressure of 285 psi is still well below the safe carrying capacity of the pipe. The design of the Fulflo valves is such that if used within their rating and with properly selected springs, the overpressure is not sufficient to endanger system or system components.

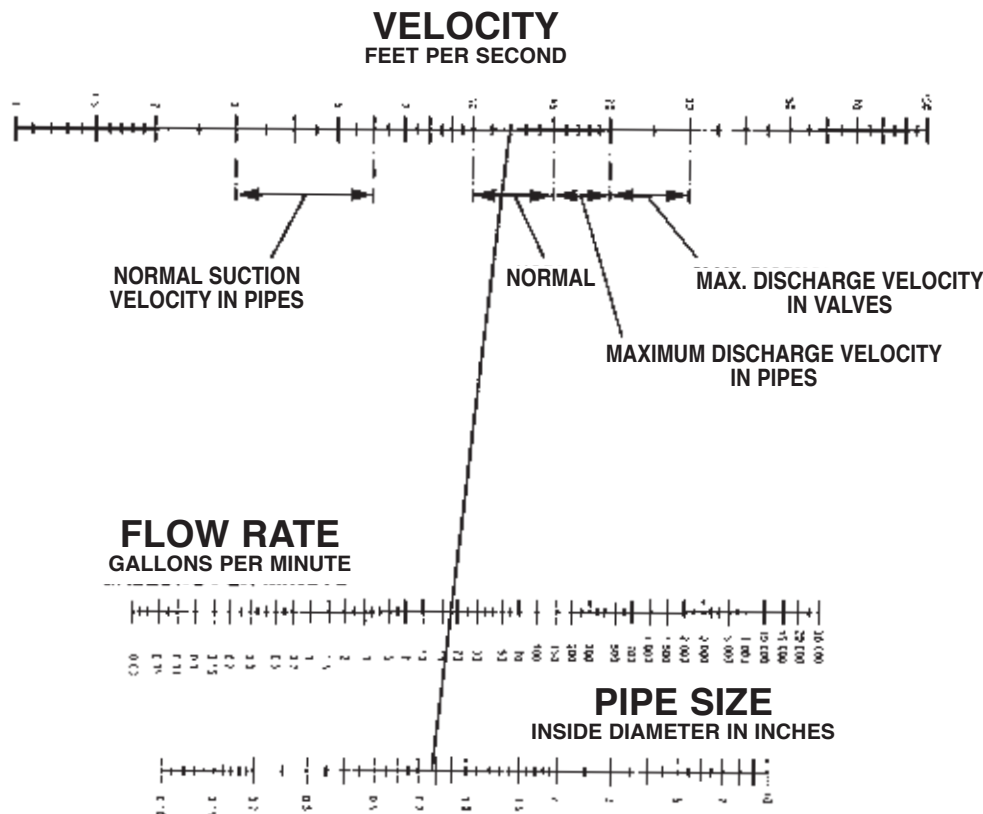

# APPLICATIONS

## APPLICATION 1

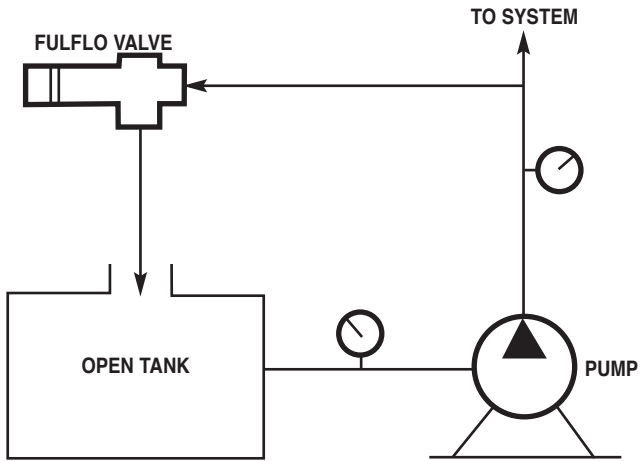

### OPEN TANK

VALVE SET PRESSURE EQUALS  
SYSTEM OPERATING PRESSURE

## APPLICATION 2

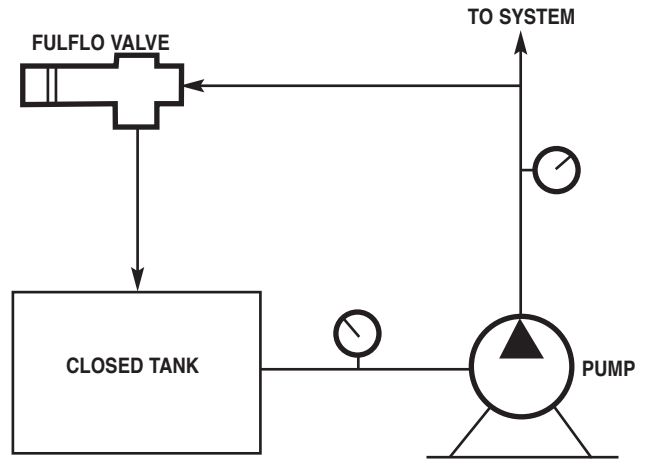

### CLOSED TANK

TANK PRESSURE + VALVE SET PRESSURE  
EQUALS SYSTEM OPERATING PRESSURE  
(EXCLUDING OV-SERIES)

## APPLICATION 3

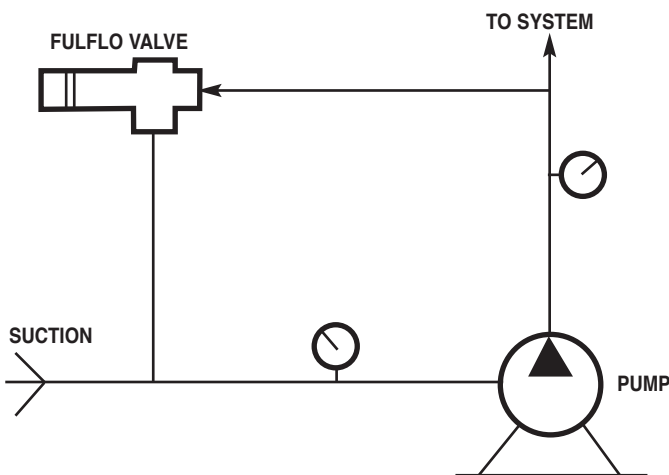

### CLOSED LOOP

SUCTION PRESSURE + VALVE SET PRESSURE  
EQUALS SYSTEM OPERATING PRESSURE  
(EXCLUDING OV-SERIES)

## APPLICATION 4

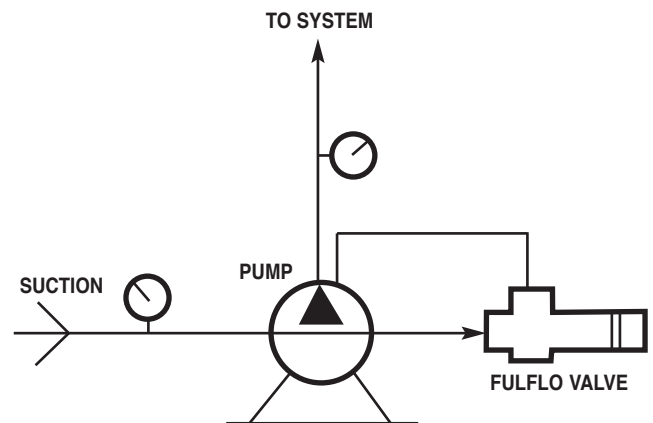

### PUMP INTERNAL RELIEF

FOR PUMPS WITH (2) SUCTION PORTS  
AND (2) DISCHARGE PORTS

SUCTION PRESSURE + VALVE SET PRESSURE  
EQUALS SYSTEM OPERATING PRESSURE  
(EXCLUDING OV-SERIES)

# SPRING MATERIAL & TEMPERATURE CHART

VALVE SIZE	PART NO.	MATERIAL				MAX TEMP.				ASTM SPEC.					
		17-7PHSS	18-8SS	CHR. VANADIUM	OIL TEMP.	MUSIC WIRE	650 F	550 F	425 F	250 F	313 TYPE 631	A581 COND. A	A 231	229	228
3/8"	207-AS		•												
	207-US		•												
	207-WS		•												
	207-XS		•												
	207-YS	•													
	207-ZS	•													
	207-RS	•													
	207-TS	•													
1/2"	307-AS		•												
	307-US		•												
	307-WS		•												
	307-XS	•													
	307-YS	•													
	307-ZS	•													
	307-RS	•													
	307-TS	•													
3/4"	407-AS		•												
	407-US		•												
	407-WS		•												
	407-XS	•													
	407-ZS	•													
1"	507-AS		•												
	507-US		•												
	507-WS		•												
	507-XS	•													
	507-YS	•													
	507-ZS	•													
1 1/4"	607-AS		•												
	607-US		•												
	607-WS		•												
	607-XS	•													
	607-YS	•													
	607-ZS	•													
	607-R	•													

VALVE SIZE	PART NO.	MATERIAL				MAX TEMP.				ASTM SPEC.					
		17-7PHSS	18-8SS	CHR. VANADIUM	OIL TEMP.	MUSIC WIRE	650 F	550 F	425 F	250 F	313 TYPE 631	A581 COND. A	A 231	229	228
1 1/2"	707-AS		•												
	707-US		•												
	707-WS		•												
	707-XS	•													
	707-YS	•													
	707-ZS	•													
	707-R	•													
	807-AS		•												
807-US		•													
807-WS		•													
807-XS	•														
807-YS	•														
807-ZS	•														
2 1/2"	A0960D		•												
	A0961C		•												
	A0970D		•												
	A0971C		•												
A0980D		•													
3"	A1060D		•												
	A1061C		•												
	A1070D		•												
	A1071C		•												
	A1080D		•												
4"	A1160D		•												
	A1170D		•												
	A1181D		•												
4" 3" 2 1/2"	A1190D		•												

## NOTES

---



---



---



---



---

# SAE O-RING BOSS CONNECTIONS

VALVE SIZE	SAE J1926								
	5	6	8	10	12	16	20	24	32
3/8"	X	X	X						
1/2"		X	X	X					
3/4"					X				
1"					X	X	X		
1 1/4"							X	X	
1 1/2"								X	
2"									X

SAE (Society Automotive Engineers)

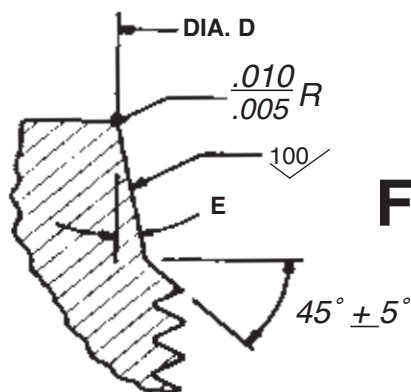
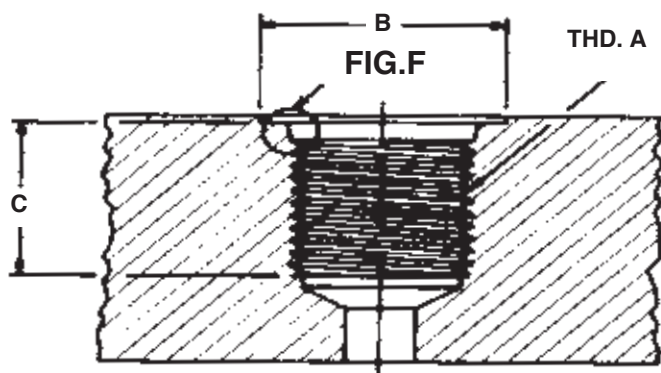

DIMENSIONS (INCHES)

SAE NO.	A	B	C	D	E
5	1/2"-20	.937	.547	.550	12°F
6	9/16"-18	1.000	.609	.616	12°F
8	3/4"-16	1.218	.688	.811	12°F
10	7/8"-14	1.375	.781	.942	15°F
12	1 1/16"-12	1.656	.906	1.148	15°F
16	1 5/16"-12	2.000	.906	1.398	15°F
20	1 5/8"-12	2.312	.906	1.713	15°F
24	1 7/8"-12	2.562	.906	1.962	15°F
32	2 1/2"-12	3.192	.906	2.587	15°F

VALVE SIZE	SAE NO.	MATERIAL			
		CAST IRON	BRASS	STEEL	STAINLESS
3/8"	5	SVJ-2039	SVB-2039	SVS-2039	SVSS-2039
	6	SVJ-2036	SVB-2036	SVS-2036	SVSS-2036
	8	SVJ-2042	SVB-2042	SVS-2042	SVSS-2042
1/2"	6	SVJ-3065	SVB-3065	SVS-3065	SVSS-3065
	8	SVJ-3066	SVB-3066	SVS-3066	SVSS-3066
	10	SVJ-3051	SVB-3051	SVS-3051	SVSS-3051
3/4"	12	SVJ-4049	SVB-4049	SVS-4049	SVSS-4049
1"	12	SVJ-5084	SVB-5084	SVS-5084	SVSS-5084
	16	SVJ-5071	SVB-5071	SVS-5071	SVSS-5071
	20	SVJ-5083	SVB-5083	SVS-5083	SVSS-5083
1 1/4"	20	SVJ-6065	SVB-6065	SVS-6065	SVSS-6065
	24	SVJ-6066	SVB-6066	SVS-6066	SVSS-6066
1 1/2"	24	SVJ-7050	SVB-7050	SVS-7050	SVSS-7050
2"	32	SVJ-8047	SVB-8047	SVS-8047	SVSS-8047



# SOCKET WELD & STANDARD MATERIALS

## SOCKET WELD

VALVE SIZE	MODEL NUMBER		AA		BB
	STEEL	STAINLESS	MIN.	MAX.	
3/8"	SVS-2033	SVSS-2033	.685	.690	.312
1/2"	SVS-3037	SVSS-3037	.850	.855	.437
3/4"	SVS-4038	SVSS-4038	1.060	1.065	.562
1"	SVS-5024	SVSS-5024	1.325	1.330	.625
1 1/4"	SVS-6058	SVSS-6058	1.670	1.675	.750
1 1/2"	SVS-7067	SVSS-7067	1.910	1.915	.812
2"	SVS-8070	SVSS-8070	2.410	2.415	.875

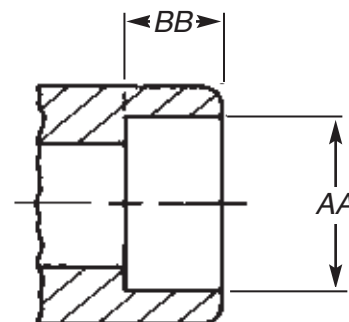

## ASTM/ASME SPECIFICATIONS (Materials Subject to Change)

### Adjusting Screws

#### Stop Rings, Glands, Bonnets

- Brass – ASTM B16
- Steel – ASTM 108
- Stainless Steel – ASME ASME SA479
- Stop Rings Only Class 316

### Locknuts, Retainers

- Steel – ASTM 108
- Stainless Steel – ASTM A582 Class 303
- ASTM A484 Class 303
- Brass – ASTM B16

### Bodies

- Cast Iron – ASTM A126-42 Class A
- Brass – ASME B62
- Steel – ASTM A 216 Grade WCB
- Stainless Steel – ASTM A 351 CF8M
- ASTM A 743 CF8M

### Caps

- Cast Iron – 401 thru 801 ASTM A 48 Class 30
- Brass – 201-B thru 501-B ASTM B16
- Brass – 601B thru 801-B ASME B62
- Steel – ASTM 108, ASTM A216 WCB
- Stainless Steel – ASTM A484, ASTM A351 CF8M

### Pistons

- Hardened Steel – ASTM 108
- 416 - SS – ASTM A 582 Cond. A, ASTM A484
- 303 - SS – ASTM A 582 Class 303, ASTM A484

## O-RING & PAD MATERIAL SPECIFICATIONS

MATERIAL	SUFFIX CODE	COMPOUND	TEMP. RANGE		ASTM SPEC.
			MIN.	MAX.	
BUNA	R	B 46	-40°F	257°F	D2000
ETHYLENE-PROPYLENE	EPR	E 50	-67°F	302°F	D2000
VITON	RV	V 14	-31°F	437°F	D2000
SILICONE	RS	S 71	-103°F	482°F	D2000
TEFLON	RT	--	-423°F	500°F	D2000
NEOPRENE	RN	--	-67°F	284°F	D2000
AFLAS	RA	--	-25°F	450°F	D2000

## MAX / MIN TEMP. OF BODIES

MATERIAL	MIN TEMP.	MAX TEMP.
CAST IRON	-20°F	400°F
BRASS	-20°F	400°F
STEEL	-30°F	600°F
STAINLESS STEEL	-50°F	600°F

## MAXIMUM ALLOWABLE WORKING PRESSURE

CAST IRON	1500 PSI
BRASS	1500 PSI
STEEL	2000 PSI
STAINLESS STEEL	2000 PSI

## ORIFICE AREA & PISTON/BODY TOLERANCES

DIMENSIONS IN INCHES

VALVE SIZE	PISTON DIA. ±.000-.0003	AREA IN <sup>2</sup>	BODY GO RC 3 FIT	BODY NO GO RC 3 FIT
3/8	.4985	.195	.4993	.4999
1/2	.6235	.305	.6243	.6249
3/4	.7485	.440	.7493	.7499
1	.9985	.783	.9993	1.0003
1 1/4	1.2485	1.224	1.2495	1.2507
1 1/2	1.4985	1.764	1.4995	1.5007
2	1.9985	3.167	1.9997	2.0011
2 1/2	2.6500	5.515	2.6517	2.6527
3	3.1235	7.663	3.1247	3.1261
4	4.1222	13.346	4.1250	4.1262

# FLANGE AND DRILLING DIMENSIONS (INCHES)

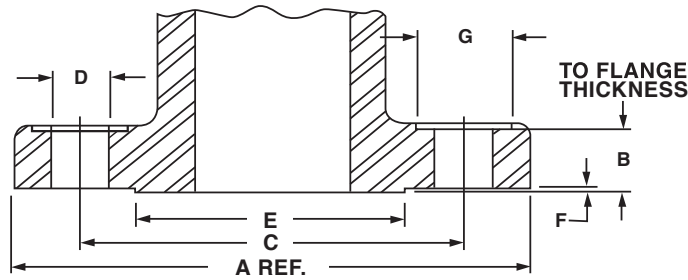

## CLASS 125 (CAST IRON) CLASS 150 (BRASS – STEEL – STAINLESS STEEL)

Valve Size	A Flange Diameter	B Flange Thickness		C Bolt Circle Diameter	D Bolt Holes Diameter	E Raised Face Diameter	F Raised Face Height	G Spotface Diameter	Number of Bolts
		Brass	Cl/Steel						
1"	4 <sup>1</sup> / <sub>4</sub> "	3/8"	9/16"	3 <sup>1</sup> / <sub>8</sub> "	5/8"	2"	1/16"	1.12	4
1 <sup>1</sup> / <sub>4</sub> "	4 <sup>5</sup> / <sub>8</sub> "	13/32"	5/8"	3 <sup>1</sup> / <sub>2</sub> "	5/8"	2 <sup>1</sup> / <sub>2</sub> "	1/16"	1.12	4
1 <sup>1</sup> / <sub>2</sub> "	5"	7/16"	11/16"	3 <sup>7</sup> / <sub>8</sub> "	5/8"	2 <sup>7</sup> / <sub>8</sub> "	1/16"	1.12	4
2"	6"	1/2"	3/4"	4 <sup>3</sup> / <sub>4</sub> "	3/4"	3 <sup>5</sup> / <sub>8</sub> "	1/16"	1.37	4
2 <sup>1</sup> / <sub>2</sub> "*	7"	N/A	7/8"	5 <sup>1</sup> / <sub>2</sub> "	3/4"	4 <sup>1</sup> / <sub>8</sub> "	1/16"	1.37	4
3"*	7 <sup>1</sup> / <sub>2</sub> "	N/A	15/16"	6"	3/4"	5"	1/16"	1.37	4
4"*	9"	N/A	15/16"	7 <sup>1</sup> / <sub>2</sub> "	3/4"	6 <sup>3</sup> / <sub>16</sub> "	1/16"	1.37	8

Note: Brass flanges conform to 150# ANSI B 16.24 *except* with raised face. Cast iron and steel flanges conform to 150# ASME B 16.5 steel specifications.

\*Available in Cast Iron & Steel only. 125-250 AARH flange finish (Steel & Stainless Steel only)

## CLASS 250 (CAST IRON)

Valve Size	A Flange Diameter	B Flange Thickness	C Bolt Circle Diameter	D Bolt Holes Diameter	E Raised Face Diameter	F Raised Face Height	G Spotface Diameter	Number of Bolts
1"	4 <sup>7</sup> / <sub>8</sub> "	11/16"	3 <sup>1</sup> / <sub>2</sub> "	3/4"	2 <sup>11</sup> / <sub>16</sub> "	1/16"	1.37	4
1 <sup>1</sup> / <sub>4</sub> "	5 <sup>1</sup> / <sub>4</sub> "	3/4"	3 <sup>7</sup> / <sub>8</sub> "	3/4"	3 <sup>1</sup> / <sub>16</sub> "	1/16"	1.37	4
1 <sup>1</sup> / <sub>2</sub> "	6 <sup>1</sup> / <sub>8</sub> "	13/16"	4 <sup>1</sup> / <sub>2</sub> "	7/8"	3 <sup>9</sup> / <sub>16</sub> "	1/16"	1.56	4
2"	6 <sup>1</sup> / <sub>2</sub> "	7/8"	5	3/4"	4 <sup>3</sup> / <sub>16</sub> "	1/16"	1.37	8

Note: Cast iron flanges conform to 250# ASME B 16.2 steel specifications.

## CLASS 300 (BRASS – STEEL – STAINLESS STEEL)

Valve Size	A Flange Diameter	B Flange Thickness	C Bolt Circle Diameter	D Bolt Holes Diameter	E Raised Face Diameter	F Raised Face Height	G Spotface Diameter	Number of Bolts
1"	4 <sup>7</sup> / <sub>8</sub> "	11/16"	3 <sup>1</sup> / <sub>2</sub> "	3/4"	2"	1/16"	1.37	4
1 <sup>1</sup> / <sub>4</sub> "	5 <sup>1</sup> / <sub>4</sub> "	3/4"	3 <sup>7</sup> / <sub>8</sub> "	3/4"	2 <sup>1</sup> / <sub>2</sub> "	1/16"	1.37	4
1 <sup>1</sup> / <sub>2</sub> "	6 <sup>1</sup> / <sub>8</sub> "	13/16"	4 <sup>1</sup> / <sub>2</sub> "	7/8"	2 <sup>7</sup> / <sub>8</sub> "	1/16"	1.56	4
2"	6 <sup>1</sup> / <sub>2</sub> "	7/8"	5"	3/4"	3 <sup>5</sup> / <sub>8</sub> "	1/16"	1.37	8
2 <sup>1</sup> / <sub>2</sub> "	7 <sup>1</sup> / <sub>2</sub> "	1"	5 <sup>7</sup> / <sub>8</sub> "	7/8"	4 <sup>1</sup> / <sub>8</sub> "	1/16"	1.56	8
3"	8 <sup>1</sup> / <sub>4</sub> "	1 <sup>1</sup> / <sub>8</sub> "	6 <sup>5</sup> / <sub>8</sub> "	7/8"	5"	1/16"	1.56	8
4"	10"	1 <sup>1</sup> / <sub>4</sub> "	7 <sup>7</sup> / <sub>8</sub> "	7/8"	6 <sup>3</sup> / <sub>16</sub> "	1/16"	1.56	8

Note: Available in steel and cast iron only. Brass flanges conform to 300# ANSI B 16.24 *except* with raised face.

Steel flanges conform to 300# ASME B 16.5 steel specifications. 125-250 AARH flange finish (Steel & Stainless Steel only)

## CLASS 600 (STEEL – STAINLESS STEEL)

Valve Size	A Flange Diameter	B Flange Thickness	C Bolt Circle Diameter	D Bolt Holes Diameter	E Raised Face Diameter	F Raised Face Height	G Spotface Diameter	Number of Bolts
1"	4 <sup>7</sup> / <sub>8</sub> "	15/16"	3 <sup>1</sup> / <sub>2</sub> "	3/4"	2"	1/4"	1.37	4
1 <sup>1</sup> / <sub>4</sub> "	5 <sup>1</sup> / <sub>4</sub> "	1 <sup>1</sup> / <sub>16</sub> "	3 <sup>7</sup> / <sub>8</sub> "	3/4"	2 <sup>1</sup> / <sub>2</sub> "	1/4"	1.37	4
1 <sup>1</sup> / <sub>2</sub> "	6 <sup>1</sup> / <sub>8</sub> "	1 <sup>1</sup> / <sub>8</sub> "	4 <sup>1</sup> / <sub>2</sub> "	7/8"	2 <sup>7</sup> / <sub>8</sub> "	1/4"	1.56	4
2"	6 <sup>1</sup> / <sub>2</sub> "	1 <sup>1</sup> / <sub>4</sub> "	5"	3/4"	3 <sup>5</sup> / <sub>8</sub> "	1/4"	1.37	8
2 <sup>1</sup> / <sub>2</sub> "	7 <sup>1</sup> / <sub>2</sub> "	1 <sup>3</sup> / <sub>8</sub> "	5 <sup>7</sup> / <sub>8</sub> "	7/8"	4 <sup>1</sup> / <sub>8</sub> "	1/4"	1.56	8
3"	8 <sup>1</sup> / <sub>4</sub> "	1 <sup>1</sup> / <sub>2</sub> "	6 <sup>5</sup> / <sub>8</sub> "	7/8"	5"	1/4"	1.56	8
4"	10 <sup>3</sup> / <sub>4</sub> "	1 <sup>3</sup> / <sub>4</sub> "	8 <sup>1</sup> / <sub>2</sub> "	1"	6 <sup>3</sup> / <sub>16</sub> "	1/4"	1.78	8

Note: Steel flanges conform to 600# ASME B 16.5 steel specifications. 125-250 AARH flange finish (Steel & Stainless Steel only)

Note: Special Flanges With Drilling On Or Off Center And Smooth Or Raised Face Are Available Upon Request.

# V-SERIES VALVES

## Installation, Maintenance & Operating Instructions



Standard  
with Screw  
Connections



Standard  
with Flange  
Connections



Stainless Steel  
with Screw  
Connections



Handwheel  
with Screw  
Connections



Handwheel  
with Flange  
Connections

### APPLICATION

The Fulflo "V"-Series range in size from 3/8" through 2" and operate efficiently with liquids of any viscosity at pressures from 3 to 1000 P.S.I. The V-Series valves are available in flange or screw type...cartridge or handwheel in a choice of brass, cast iron, steel and stainless steel.

Widely used in a variety of applications, the "V"-Series valves are ideally suited in hydraulic and lubricating systems for load regulation and system protection. Special trim or packings are available for use with fire resisting fluids and other liquids of this type. Unusual applications and special requirements should be referred to our engineering staff for recommendation.

### INSTALLATION

Fulflo valves can be mounted in any position. A tee may be inserted in the pump discharge line to mount the valve. The correct size of valve should be installed, preferably matching the pump discharge line. Screw the valve into the nipple in the tee, or in the case of the flange style, bolt the valve to the companion flange screwed into the nipple. When the valve is used for frequent bypassing of oil pressure, its outlet

should be piped back to the tank. Care must be taken to have the discharge well below the oil level in the tank to prevent air entrainment and erratic operation.

Only if the valve is used as safety or overload relief and operates infrequently may its discharge be piped back into the pump suction line. Frequent or continuous operation under these conditions will cause excessive heating of the oil and possible damage.

# V-SERIES

## SETTING VALVES

Valves may be set with a hydraulic hand pump for cracking pressure. If a test stand is available, valve should be connected to the discharge header with the pump bypass open, and the bypass gradually closed until the desired pressure registers on the gauge. Adjust valve adjusting screw until valve slightly bleeds at the set bypass pressure and lock adjusting screw.

Fulflo valves are not designed to be positive shut-off, and will pass a minimal amount of leakage before the set pressure. If a valve is required to bypass a given amount of fluid at a given pressure, a test stand

having a flow meter in the pump discharge line must be available. With a valve adjusted for cracking pressure as above, continue closing bypass until the required flow registers on the flow meter and observe pressure. Readjust pressure, if necessary, to obtain desired pressure at desired flow.

## MAINTENANCE

Fulflo valves provide reliable "chatter-free" operation when the system is free of abrasives and foreign matter. Continuous filtration of the liquid used is strongly recommended.

## TYPICAL DISASSEMBLY OF STANDARD TYPE VALVE

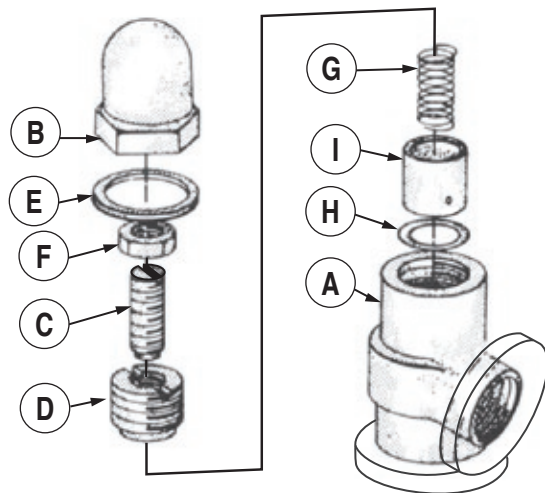

To dismantle valve for inspection or cleaning:

1. Remove cap "B"
2. Remove O-Ring "E"
3. Remove lock nut "F"
4. Remove adjusting screw "C"
5. Remove retainer "D"
6. Remove spring "G"
7. Remove piston "I"
8. Remove stop ring "H" (Not Recommended)  
(Special tooling is required to install new stop ring.)

Inspect valve bore and piston for wear and scoring. Replace broken or damaged parts. Clean all parts thoroughly and re-assemble by reversing the above procedure.

## TYPICAL DISASSEMBLY OF HANDWHEEL TYPE VALVE

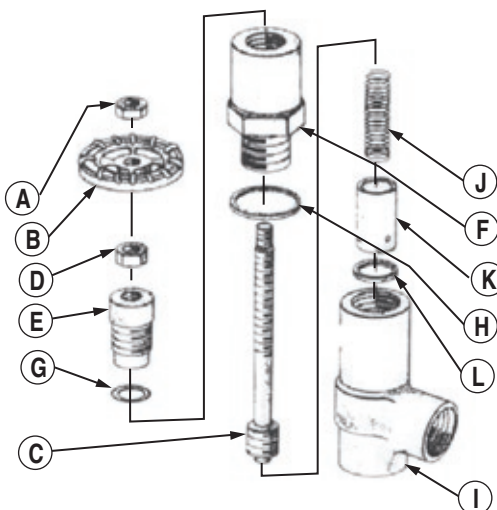

To dismantle the valve for inspection or cleaning:

1. Release spring tension by backing off handwheel as far as it will go.
2. Remove lock nut "A" or set screw and take off handwheel "B"
3. Remove lock nut "D"
4. Unscrew and remove gland "E"
5. Unscrew and remove bonnet "F"
6. Remove O-Ring "H"
7. Remove adjusting screw "C" (turn clockwise and pull out from bottom of bonnet "F")
8. Remove O-ring packing "G"
9. Remove spring "J"
10. Remove piston "K"
11. Remove stop ring "L" (Not Recommended)  
(Special tooling is required to install new stop ring.)

Inspect valve bore and piston for wear or scoring. Replace broken or damaged parts. Clean all parts thoroughly and re-assemble by reversing the above procedure.



# V-SERIES

## ASSEMBLY NUMBER IDENTIFICATION CHART

Symbol No.	Designation	Code	Description
1	Style	None H	Standard Model Handwheel Model
2	Series	V	
3	Material	J B S SS	Cast iron Brass Steel Stainless Steel (300 Series Stainless)
4	Connections	None F	Screw Connections Flange Connections 300# Flange Class Standard (250# Flange Class - Cast Iron Standard)
5	Size	-2 -3 -4 -5 -6 -7 -8	3/8" 1/2" 3/4" 1" 1 1/4" 1 1/2" 2"
6,7,8	ASA Flange Rating	None -150 -600	300# Flange Standard (no designation required)
9	Flange Style 150# & 600# Only	A B C D	Raised Face, Staggered Bolt Centers Smooth Face, Staggered Bolt Centers Raised Face, Bolts on Valve Centerline Smooth Face, Bolts on Valve Centerline
10	O-Ring Material	R RV RS RT RA EPR RN	Buna (standard) Viton Silicone Teflon Atlas Ethylene Propylene Neoprene
11	Options	SP P	Steel Parts (used on cast iron only) Panel Mount on Handwheel Series
12	Piston Material	/HS /SS /3SS	Hardened Steel 416 Stainless Steel 303 Stainless Steel (For Stainless Valves Only)
13	Spring	/AS /US /WS /XS /YS /ZS	
14	Setting		Desired Set Pressure

### EXAMPLES:

<b>VJ-5RVSP/HS/WS</b>							
V	J	-5	RV	SP	/HS	/WS	
<small>Series</small>	<small>Cast Iron</small>	<small>1"</small>	<small>Viton O-Ring</small>	<small>Steel Parts</small>	<small>H.S. Piston</small>	<small>WS Spring</small>	

<b>VJF-5R/HS/WS</b>							
V	J	F	-5	R	/HS	/WS	
<small>Series</small>	<small>Cast Iron</small>	<small>Flanged</small>	<small>1"</small>	<small>Buna O-Ring</small>	<small>H.S. Piston</small>	<small>WS Spring</small>	

<b>VJF-5-150AR/HS/WS</b>									
V	J	F	-5	-150	A	R	/HS	/WS	
<small>Series</small>	<small>Cast Iron</small>	<small>Flanged</small>	<small>1"</small>	<small>Rating</small>	<small>Style</small>	<small>Buna O-Ring</small>	<small>H.S. Piston</small>	<small>WS Spring</small>	

## STANDARD PRESSURE RANGE CHART

Valve Pipe Size	Valve Flange Size	SPRING PRESSURE AND IDENTIFICATION NO.															
		BLACK-AS		RED-US		GREEN-WS		YELLOW-XS		WHITE-YS		BLUE-ZS		PURPLE-TS		BROWN-RS	
		Low	High	Low	High	Low	High	Low	High	Low	High	Low	High	Low	High	Low	High
3/8"		3	10	7	35	30	100	60	175	150	350	300	500	400	600	550	750
1/2"		3	10	7	35	30	100	60	175	150	350	300	500	400	600	550	750
3/4"		3	10	7	35	30	100	60	175	150	350	300	500				
1"	1"	3	10	7	35	30	100	60	175	150	350	300	500				
1 1/4"	1 1/4"	3	10	7	35	30	100	60	175	150	350	300	500				
1 1/2"	1 1/2"	3	10	7	35	30	100	60	175	150	350	300	500				
2"	2"	3	10	7	35	30	100	60	175	150	350	250	600				

+/-1-5 PSI ON ALL SPRING RANGES

# V-SERIES

**VJ** Cast Iron  
**VS** Steel

**VB** Brass  
**VSS** Stainless Steel

**VJ-SP** Cast Iron with Steel Parts

## DIMENSIONS

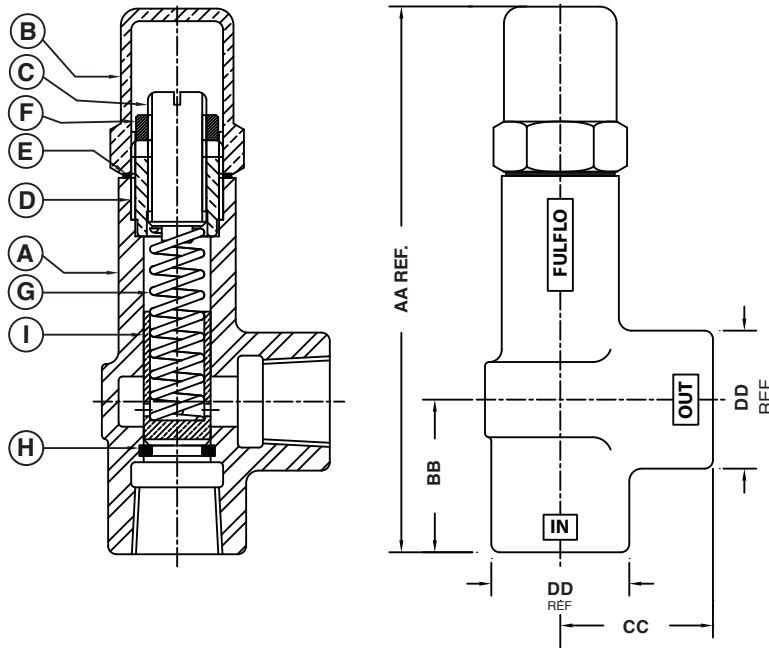

Valve Size	DIMENSIONS IN INCHES			
	AA	BB	CC	DD REF
3/8"	5 <sup>11</sup> / <sub>32</sub>	1 <sup>3</sup> / <sub>8</sub>	1 <sup>3</sup> / <sub>8</sub>	1 <sup>3</sup> / <sub>8</sub>
1/2"	6 <sup>3</sup> / <sub>16</sub>	1 <sup>11</sup> / <sub>16</sub>	1 <sup>7</sup> / <sub>16</sub>	1 <sup>7</sup> / <sub>16</sub>
3/4"	6 <sup>15</sup> / <sub>16</sub>	1 <sup>15</sup> / <sub>16</sub>	1 <sup>13</sup> / <sub>16</sub>	1 <sup>11</sup> / <sub>16</sub>
1"	8 <sup>7</sup> / <sub>32</sub>	2 <sup>9</sup> / <sub>32</sub>	2 <sup>9</sup> / <sub>32</sub>	2 <sup>1</sup> / <sub>16</sub>
1 1/4"	9 <sup>9</sup> / <sub>16</sub>	2 <sup>9</sup> / <sub>16</sub>	2 <sup>9</sup> / <sub>16</sub>	2 <sup>1</sup> / <sub>2</sub>
1 1/2"	11 <sup>1</sup> / <sub>16</sub>	2 <sup>11</sup> / <sub>16</sub>	2 <sup>11</sup> / <sub>16</sub>	2 <sup>7</sup> / <sub>8</sub>
2"	13	3	3	3 <sup>1</sup> / <sub>4</sub>

## PARTS LIST

SYM.	NAME	MODEL	VALVE SIZE						
			3/8"	1/2"	3/4"	1"	1 1/4"	1 1/2"	2"
A	BODY	VJ, VJ-SP VB VS VSS	200 200-B 200-S 200-SS	300 300-B 300-S 300-SS	400 400-B 400-S 400-SS	500 500-B 500-S 500-SS	600 600-B 600-S 600-SS	700 700-B 700-S 700-SS	800 800-B 800-S 800-SS
B	CAP (O-RING SEAL)	VJ, VJ-SP VB VS VSS	201-SR 201-BR 201-SR 201-SSR	301-SR 301-BR 301-SR 301-SSR	401-R 401-BR 401-SR 401-SSR	501-R 501-BR 501-SR 501-SSR	601-R 601-BR 601-SR 601-SSR	701-R 701-BR 701-SR 701-SSR	801-R 801-BR 801-SR 801-SSR
C	ADJUSTING SCREW	VJ, VB VS, VJ-SP VSS	202-B 202-S 202-SS	302-B 302-S 302-SS	402-B 402-S 402-SS	502-B 502-S 502-SS	602-B 602-S 602-SS	702-B 702-S 702-SS	802-B 802-S 802-SS
D	RETAINER	VJ, VB VS, VJ-SP VSS	203-B 203-S 203-SS	303-B 303-S 303-SS	403-B 403-S 403-SS	503-B 503-S 503-SS	603-B 603-S 603-SS	703-B 703-S 703-SS	803-B 803-S 803-SS
E	O-RING †	VJ, VJ-SP, VB, VS VSS	204-* 204-RT	304-* 304-RT	404-* 404-RT	504-* 504-RT	604-* 604-RT	704-* 704-RT	804-* 804-RT
F	LOCK NUT	VJ, VJ-SP, VS, VB VSS	205-S 205-SS	305-S 305-SS	405-S 405-SS	505-S 505-SS	605-S 605-SS	705-S 705-SS	805-S 805-SS
G	SPRING †	ALL MODELS	207-**	307-**	407-**	507-**	607-**	707-**	807-**
H	STOP RING	VJ, VB VS, VJ-SP VSS	208-B 208-S 208-SS	308-B 308-S 308-SS	408-B 408-S 408-SS	508-B 508-S 508-SS	608-B 608-S 608-SS	708-B 708-S 708-SS	808-B 808-S 808-SS
I	PISTON †	HARDENED STEEL 416 STAINLESS STEEL 303 STAINLESS STEEL	206 206-A 206-SS	306 306-A 306-SS	406 406-A 406-SS	506 506-A 506-SS	606 606-A 606-SS	706 706-A 706-SS	806 806-A 806-SS
B	CAP (GASKET SEAL)	VJ, VJ-SP VB VS	201-S 201-B 201-S	301-S 301-B 301-S	401 401-B 401-S	501 501-B 501-S	601 601-B 601-S	701 701-B 701-S	801 801-B 801-S
E	GASKET †	VJ, VB VS, VJ-SP	204 204-S	304 304-S	404 404-S	504 504-S	604 604-S	704 704-S	804 804-S

\* See o-ring selection chart

\*\* See spring pressure chart

† Recommended spare parts

# V-SERIES

**VJF** Cast Iron  
**VBF** Brass

**VSF** Steel  
**VSSF** Stainless Steel

**VJF-SP** Cast Iron with Steel Parts

## DIMENSIONS

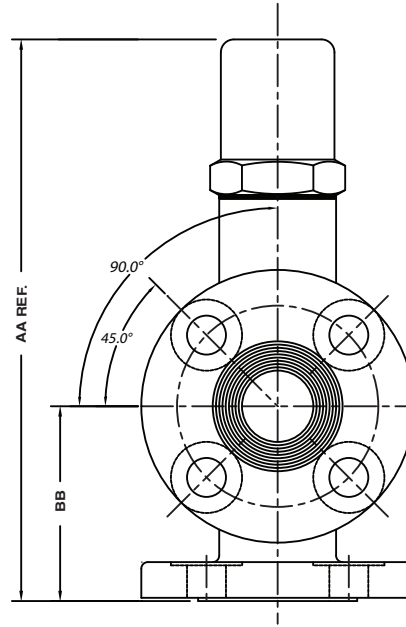
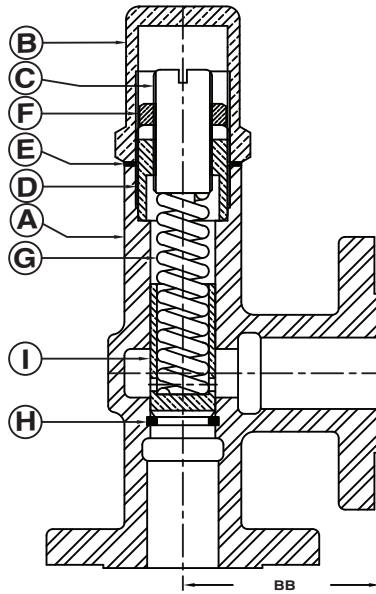

### DIMENSIONS IN INCHES

Valve Size	AA	BB
1"	9 <sup>1</sup> / <sub>2</sub> "	3 <sup>1</sup> / <sub>2</sub> "
1 <sup>1</sup> / <sub>4</sub> "	10 <sup>13</sup> / <sub>16</sub> "	3 <sup>3</sup> / <sub>4</sub> "
1 <sup>1</sup> / <sub>2</sub> "	12 <sup>7</sup> / <sub>16</sub> "	4 <sup>1</sup> / <sub>16</sub> "
2"	14 <sup>9</sup> / <sub>16</sub> "	4 <sup>9</sup> / <sub>16</sub> "

Note: Dimensions reflect 150# and 300# only

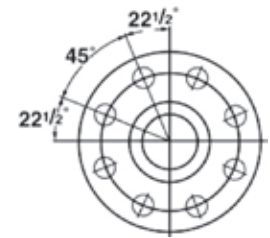

FOR 2" VALVE ONLY

## PARTS LIST

SYM.	NAME	MODEL	VALVE SIZE			
			1"	1 <sup>1</sup> / <sub>4</sub> "	1 <sup>1</sup> / <sub>2</sub> "	2"
A	BODY	VJF, VJF-SP VBF VSF VSSF	500-F 500-BF 500-SF 500-SSF	600-F 600-BF 600-SF 600-SSF	700-F 700-BF 700-SF 700-SSF	800-F 800-BF 800-SF 800-SSF
B	CAP (O-RING SEAL)	VJF, VJF-SP VBF VSF VSSF	501-R 501-BR 501-SR 501-SSR	601-R 601-BR 601-SR 601-SSR	701-R 701-BR 701-SR 701-SSR	801-R 801-BR 801-SR 801-SSR
C	ADJUSTING SCREW	VJF, VBF VSF, VJF-SP VSSF	502-B 502-S 502-SS	602-B 602-S 602-SS	702-B 702-S 702-SS	802-B 802-S 802-SS
D	RETAINER	VJF, VBF VSF, VJF-SP VSSF	503-B 503-S 503-SS	603-B 603-S 603-SS	703-B 703-S 703-SS	803-B 803-S 803-SS
E	O-RING †	VJF, VJF-SP VBF, VSF VSSF	504* 504-* 504-RT	604* 604-* 604-RT	704* 704-* 704-RT	804* 804-* 804-RT
F	LOCK NUT	VJF, VJF-SP VBF, VSF VSSF	505-S 505-S 505-SS	605-S 605-S 605-SS	705-S 705-S 705-SS	805-S 805-S 805-SS
G	SPRING †	ALL MODELS	507-**	607-**	707-**	807-**
H	STOP RING	VJF, VBF VJF-SP, VSF VSSF	508-B 508-S 508-SS	608-B 608-S 608-SS	708-B 708-S 708-SS	808-B 808-S 808-SS
I	PISTON †	HARDENED STEEL 416 STAINLESS STEEL 303 STAINLESS STEEL	506 506-A 506-SS	606 606-A 606-SS	706 706-A 706-SS	806 806-A 806-SS
B	CAP (GASKET SEAL)	VJF, VJF-SP VBF VSF	501 501-B 501-S	601 601-B 601-S	701 701-B 701-S	801 801-B 801-S
E	GASKET †	VJF, VBF VJF-SP, VSF	504 504-S	604 604-S	704 704-S	804 804-S

\* See o-ring selection chart  
\*\* See spring pressure chart  
† Recommended spare parts

# V-SERIES

**HVJ** Cast Iron  
**HVB** BRASS

**HVS** Steel  
**HVSS** Stainless Steel

**HVJ-P** Cast Iron  
**HVB-P** Brass

**HVS-P** Steel  
**HVSS-P** Stainless Steel

## DIMENSIONS

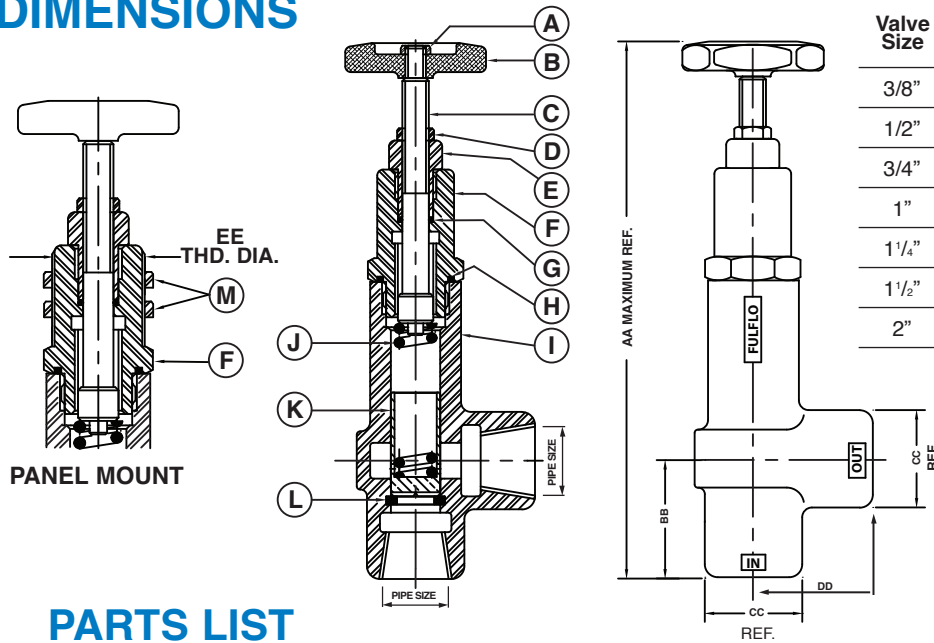

Valve Size	DIMENSIONS IN INCHES				
	AA	BB	CC	DD	EE
3/8"	8 <sup>1</sup> / <sub>8</sub>	1 <sup>3</sup> / <sub>8</sub>	1 <sup>3</sup> / <sub>8</sub>	1 <sup>3</sup> / <sub>8</sub>	7/8
1/2"	9 <sup>5</sup> / <sub>8</sub>	1 <sup>11</sup> / <sub>16</sub>	1 <sup>7</sup> / <sub>16</sub>	1 <sup>7</sup> / <sub>16</sub>	1 <sup>1</sup> / <sub>8</sub>
3/4"	9 <sup>9</sup> / <sub>16</sub>	1 <sup>15</sup> / <sub>16</sub>	1 <sup>11</sup> / <sub>16</sub>	1 <sup>13</sup> / <sub>16</sub>	1 <sup>3</sup> / <sub>8</sub>
1"	12 <sup>7</sup> / <sub>16</sub>	2 <sup>9</sup> / <sub>32</sub>	2 <sup>1</sup> / <sub>16</sub>	2 <sup>9</sup> / <sub>32</sub>	1 <sup>3</sup> / <sub>8</sub>
1 <sup>1</sup> / <sub>4</sub> "	13 <sup>7</sup> / <sub>16</sub>	2 <sup>9</sup> / <sub>16</sub>	2 <sup>1</sup> / <sub>2</sub>	2 <sup>9</sup> / <sub>16</sub>	1 <sup>5</sup> / <sub>8</sub>
1 <sup>1</sup> / <sub>2</sub> "	17 <sup>1</sup> / <sub>16</sub>	2 <sup>11</sup> / <sub>16</sub>	2 <sup>7</sup> / <sub>8</sub>	2 <sup>11</sup> / <sub>16</sub>	2 <sup>1</sup> / <sub>4</sub>
2"	17 <sup>1</sup> / <sub>16</sub>	3	3 <sup>3</sup> / <sub>8</sub>	3	2 <sup>1</sup> / <sub>4</sub>

## PARTS LIST

SYM.	NAME	MODEL	VALVE SIZE						
			3/8"	1/2"	3/4"	1"	1 <sup>1</sup> / <sub>4</sub> "	1 <sup>1</sup> / <sub>2</sub> "	2"
A	LOCK NUT OR SET SCREW	ALL MODELS	1/4"-20 COMM.	1/4"-20 COMM.	205-S	205-S	1/4"-20 COMM.	1/4"-20 COMM.	1/4"-20 COMM.
B	HANDWHEEL	ALL MODELS	229	229	429	429	629	629	629
C	ADJUSTING SCREW	HVJ(P), HVS(P) HVB(P) HVSS(P)	222-S 222-B 222-SS	322-S 322-B 322-SS	422-S 422-B 422-SS	522-S 522-B 522-SS	622-S 622-B 622-SS	722-S 722-B 722-SS	822-S 822-B 822-SS
D	LOCK NUT	HVJ(P), HVS(P) HVB(P) HVSS(P)	205-S 205-S 205-SS	205-S 205-S 205-SS	305-S 305-S 305-SS	305-S 305-S 305-SS	655-S 655-S 655-SS	655-S 655-S 655-SS	655-S 655-S 655-SS
E	GLAND	HVJ(P), HVS(P) HVB(P) HVSS(P)	225-S 225-B 225-SS	325-S 325-B 325-SS	525-S 525-B 525-SS	525-S 525-B 525-SS	625-S 625-B 625-SS	725-S 725-B 725-SS	825-S 825-B 825-SS
F	BONNET	HVJ, HVS HVB HVSS HVJ(P), HVS(P) HVB(P) HVSS(P)	223-SR 223-BR 223-SSR 228-SR 228-BR 228-SSR	323-SR 323-BR 323-SSR 328-SR 328-BR 328-SSR	423-SR 423-BR 423-SSR 428-SR 428-BR 428-SSR	523-SR 523-BR 523-SSR 528-SR 528-BR 528-SSR	623-SR 623-BR 623-SSR 628-SR 628-BR 628-SSR	723-SR 723-BR 723-SSR 728-SR 728-BR 728-SSR	823-SR 823-BR 823-SSR 828-SR 828-BR 828-SSR
G	O-RING †	HVJ(P), HVS(P) HVB(P) HVSS(P) only	224* 224* 224-RT	224* 224* 224-RT	424* 424* 424-RT	424* 424* 424-RT	624* 624* 624-RT	624* 624* 624-RT	624* 624* 624-RT
H	O-RING †	HVJ(P), HVS(P) HVB(P) HVSS(P) only	204* 204* 204-RT	304* 304* 304-RT	404* 404* 404-RT	504* 504* 504-RT	604* 604* 604-RT	704* 704* 704-RT	804* 804* 804-RT
I	BODY	HVJ(P) HVB(P) HVS(P) HVSS(P)	200 200-B 200-S 200-SS	300 300-B 300-S 300-SS	400 400-B 400-S 400-SS	500 500-B 500-S 500-SS	600 600-B 600-S 600-SS	700 700-B 700-S 700-SS	800 800-B 800-S 800-SS
J	SPRING †	ALL MODELS	207-**	307-**	407-**	507-**	607-**	707-**	807-**
K	PISTON †	HARDENED STEEL 416 STAINLESS STEEL 303 STAINLESS STEEL	206 206-A 206-SS	306 306-A 306-SS	406 406-A 406-SS	506 506-A 506-SS	606 606-A 606-SS	706 706-A 706-SS	806 806-A 806-SS
L	STOP RING	HVJ(P), HVS(P) HVB(P) HVSS(P)	208-S 208-B 208-SS	308-S 308-B 308-SS	408-S 408-B 408-SS	508-S 508-B 508-SS	608-S 608-B 608-SS	708-S 708-B 708-SS	808-S 808-B 808-SS
M	LOCK NUTS 2 REQ'D	HVJ(P), HVS(P), HVB(P) HVSS(P)	505-S 505-S 505-SS	605-S 605-S 605-SS	705-S 705-S 705-SS	705-S 705-S 705-SS	805-S 805-S 805-SS	745-S 745-S 745-SS	745-S 745-S 745-SS

\* See o-ring selection chart

\*\* See spring pressure chart

† Recommended spare parts



# V-SERIES

**HVJF** Cast Iron  
**HVBF** Brass

**HVSF** Steel  
**HVSSF** Stainless Steel

**HVJF-P** Cast Iron  
**HVBF-P** Brass

**HVSF-P** Steel  
**HVSSF-P** Stainless Steel

## DIMENSIONS

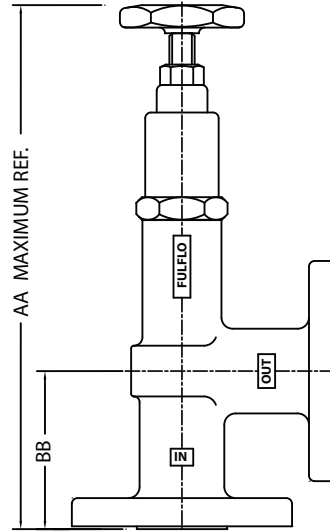
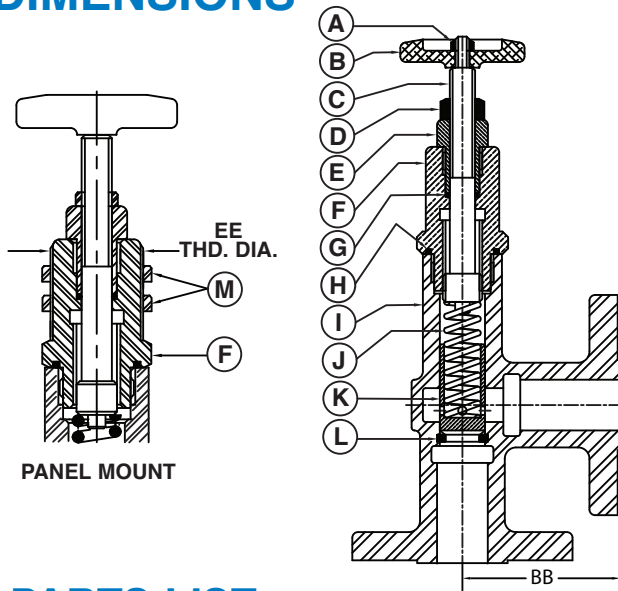

### DIMENSIONS IN INCHES

Valve Size	AA	BB	EE
1"	13 <sup>11</sup> / <sub>16</sub>	3 <sup>1</sup> / <sub>2</sub>	1 <sup>3</sup> / <sub>8</sub>
1 <sup>1</sup> / <sub>4</sub> "	14 <sup>11</sup> / <sub>16</sub>	3 <sup>3</sup> / <sub>4</sub>	1 <sup>5</sup> / <sub>8</sub>
1 <sup>1</sup> / <sub>2</sub> "	18 <sup>7</sup> / <sub>16</sub>	4 <sup>1</sup> / <sub>16</sub>	2 <sup>1</sup> / <sub>4</sub>
2"	18 <sup>5</sup> / <sub>8</sub>	4 <sup>9</sup> / <sub>16</sub>	2 <sup>1</sup> / <sub>4</sub>

Note: Dimensions reflect 150# and 300# only

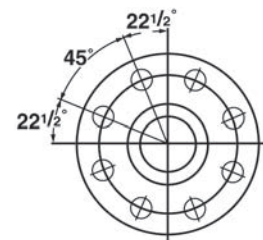

FOR 2" VALVE ONLY

## PARTS LIST

SYM.	NAME	MODEL	DIMENSIONS IN INCHES			
			1"	1 <sup>1</sup> / <sub>4</sub> "	1 <sup>1</sup> / <sub>2</sub> "	2"
A	LOCK NUT OR SET SCREW	ALL MODELS	205-S	1/4"-20 COMM.	1/4"-20 COMM.	1/4"-20 COMM.
B	HANDWHEEL	ALL MODELS	429	629	629	629
C	ADJUSTING SCREW	HVJF(P), HVSF(P) HVBF(P) HVSSF(P)	522-S 522-B 522-SS	622-S 622-B 622-SS	722-S 722-B 722-SS	822-S 822-B 822-SS
D	LOCK NUT	HVJF(P), HVSF(P) HVBF(P) HVSSF(P) only	305-S 305-S 305-SS	655-S 655-S 655-SS	655-S 655-S 655-SS	655-S 655-S 655-SS
E	GLAND	HVJF(P), HVSF(P) HVBF(P) HVSSF(P)	525-S 525-B 525-SS	625-S 625-B 625-SS	725-S 725-B 725-SS	825-S 825-B 825-SS
F	BONNET	HVJF, HVSF HVBF HVSSF HVJF(P) HVBF(P), HVSF(P) HVSSF(P)	523-SR 523-BR 523-SSR 528-SR 528-BR 528-SSR	623-SR 623-BR 623-SSR 628-SR 628-BR 628-SSR	723-SR 723-BR 723-SSR 728-SR 728-BR 728-SSR	823-SR 823-BR 823-SSR 828-SR 828-BR 828-SSR
G	O-RING †	HVJF(P), HVSF(P) HVBF(P) HVSSF(P) only	424* 424* 424-RT	624* 624* 624-RT	624* 624* 624-RT	624* 624* 624-RT
H	O-RING †	HVJF(P), HVSF(P) HVBF(P) HVSSF(P) only	504* 504* 504-RT	604* 604* 604-RT	704* 704* 704-RT	804* 804* 804-RT
I	BODY	HVJF(P) HVBF(P) HVSF(P) HVSSF(P)	500-F 500-BF 500-SF 500-SSF	600-F 600-BF 600-SF 600-SSF	700-F 700-BF 700-SF 700-SSF	800-F 800-BF 800-SF 800-SSF
J	SPRING †	ALL MODELS	507**	607**	707**	807**
K	PISTON †	HARDENED STEEL 416 STAINLESS STEEL 303 STAINLESS STEEL	506 506-A 506-SS	606 606-A 606-SS	706 706-A 706-SS	806 806-A 806-SS
L	STOP RING	HVJF(P), HVSF(P) HVBF(P) HVSSF(P)	508-S 508-B 508-SS	608-S 608-B 608-SS	708-S 708-B 708-SS	808-S 808-B 808-SS
M	LOCK NUTS 2 REQ'D	HVJF(P), HVSF(P), HVBF(P) HVSSF(P)	705-S 705-S 705-SS	805-S 805-S 805-SS	745-S 745-S 745-SS	745-S 745-S 745-SS

\* See o-ring selection chart

\*\* See spring pressure chart

† Recommended spare parts

V-SERIES  
VALVES

# V-SERIES PERFORMANCE CHARTS

All valve tests 110°F. to 120°F. Oil Viscosity 150 S.S.U. at 100°F.  
(Charts good from 30 to 500 S.S.U.)

V-SERIES  
VALVES

3/8" VALVE TESTS

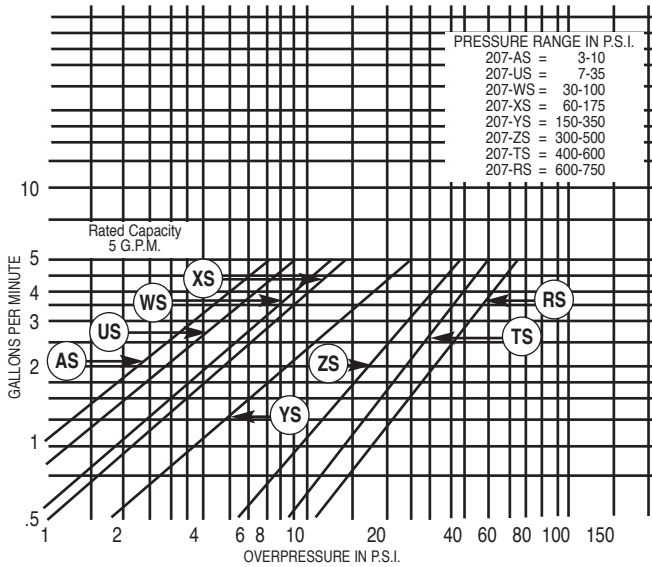

1/2" VALVE TESTS

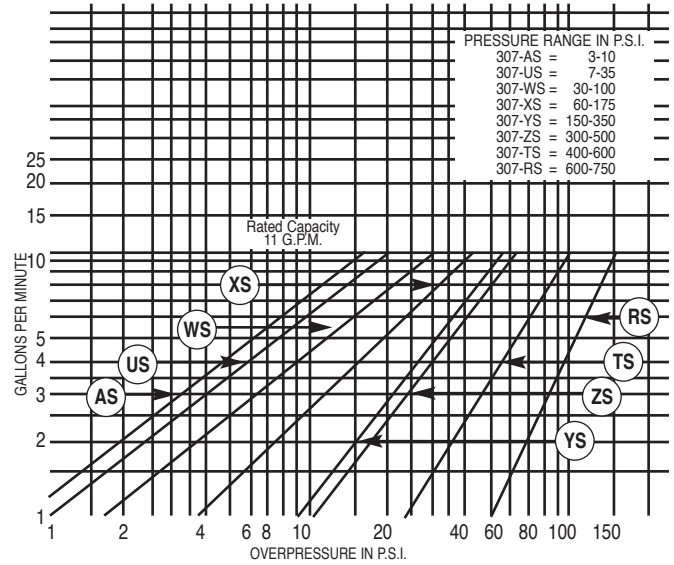

3/4" VALVE TESTS

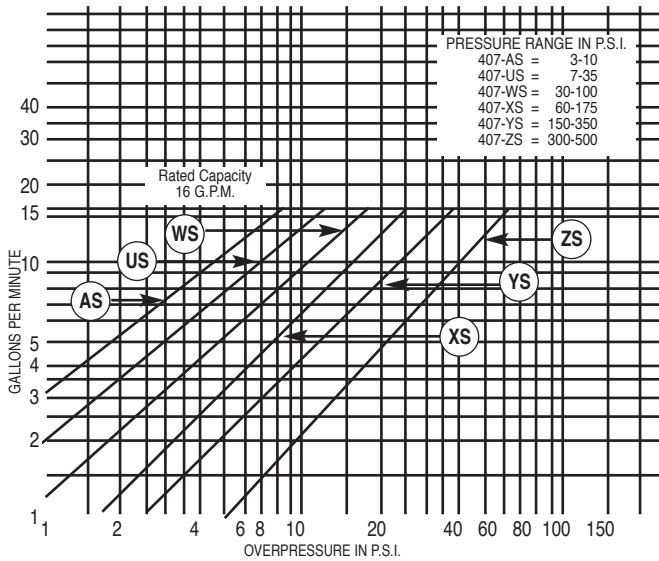

1" VALVE TESTS

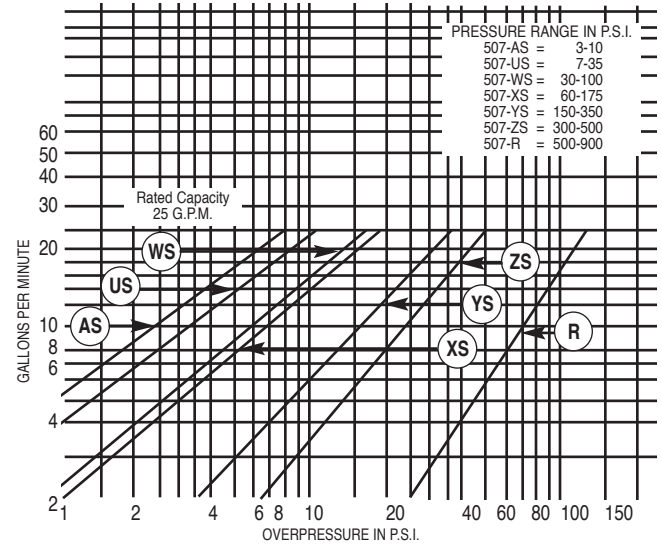

**Overpressure** - The pressure increase or accumulation above the set pressure when the valve is discharging flow.

# V-SERIES PERFORMANCE CHARTS

All valve tests 110°F. to 120°F. Oil Viscosity 150 S.S.U. at 100°F.  
(Charts good from 30 to 500 S.S.U.)

V-SERIES  
VALVES

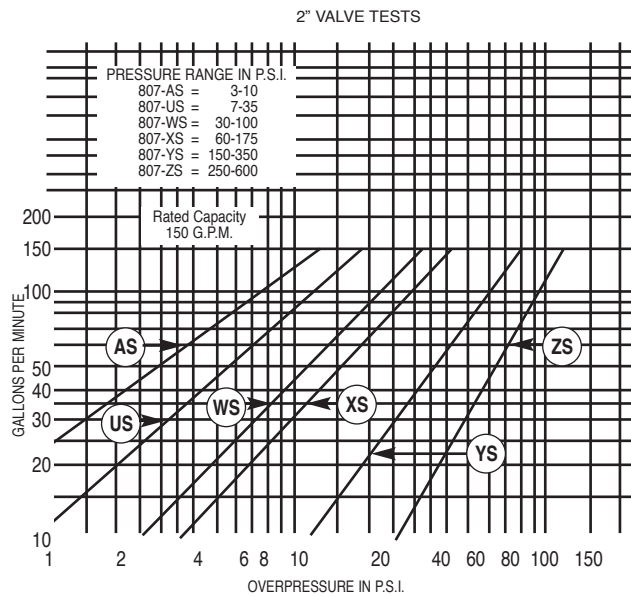
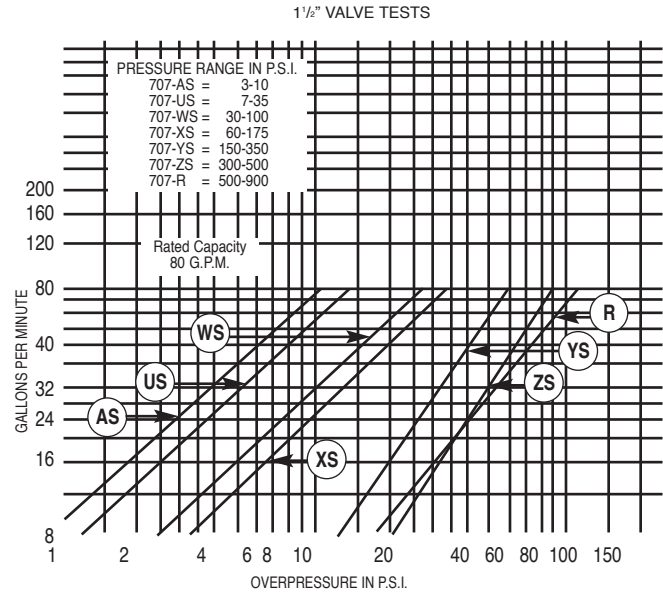
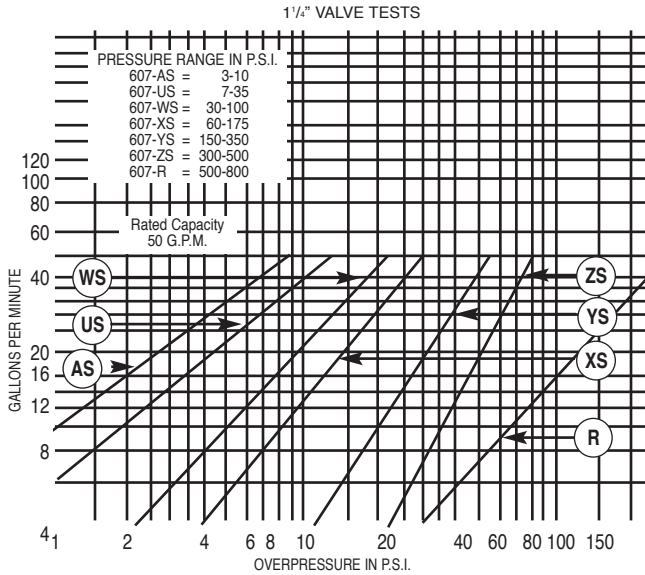

**Overpressure** - The pressure increase or accumulation above the set pressure when the valve is discharging flow.

# FV-SERIES VALVE

## Installation, Maintenance & Operating Instructions



The Fulflo FV-Series valve is similar to the V-Series valve, includes a new safer design that protects liquid and gasses from venting out of the valve during normal operation and adjustment conditions. This valve has been

especially designed to prevent the adjusting screw from backing out while making adjustments to the pressure setting. An o-ring has been incorporated around the adjusting screw to further prevent liquid from escaping.

### APPLICATION

The Fulflo “FV” Series range in size from 3/8” through 2” and operate efficiently with liquids of any viscosity at pressures from 2 to 1000 P.S.I. The “FV” series valves are available in flange or screw type... in a choice of brass, cast iron, steel and stainless steel.

Widely used in a variety of applications, the “FV” series valves are ideally suited in hydraulic and lubricating systems for load regulation and system protection. Special trim or packings are available for use with fire resisting fluids and other liquids of this type. Unusual applications and special requirements should be referred to our engineering staff for recommendation.

### INSTALLATION

Fulflo valves can be mounted in any position. A tee may be inserted in the pump discharge line to mount the valve. The correct size of valve should be installed, preferably matching the pump discharge line. Screw the valve into the nipple in the tee, or in the case of the flange style, bolt the valve to the companion flange screwed into the nipple. When the valve is used for frequent bypassing of oil pressure, its outlet

should be piped back to the tank. Care must be taken to have the discharge well below the oil level in the tank to prevent air entrainment and erratic operation.

Only if the valve is used as safety or overload relief and operates infrequently may its discharge be piped back into the pump suction line. Frequent or continuous operation under these conditions will cause excessive heating of the oil and possible damage.



# FV-SERIES

## SETTING VALVES

Valves may be set with a hydraulic hand pump for cracking pressure. If a test stand is available, valve should be connected to the discharge header with the pump bypass open, and the bypass gradually closed until the desired pressure registers on the gauge. Adjust valve adjusting screw until valve slightly bleeds at the set bypass pressure and lock adjusting screw.

Fulflo valves are not designed to be positive shut-off, and will pass a minimal amount of leakage before the set pressure. If a valve is required to bypass a given amount of fluid at a given pressure, a test stand

having a flow meter in the pump discharge line must be available. With a valve adjusted for cracking pressure as above, continue closing bypass until the required flow registers on the flow meter and observe pressure. Readjust pressure, if necessary, to obtain desired pressure at desired flow.

## MAINTENANCE

Fulflo valves provide reliable "chatter-free" operation when the system is free of abrasives and foreign matter. Continuous filtration of the liquid used is strongly recommended.

## TYPICAL DISASSEMBLY OF STANDARD TYPE VALVE

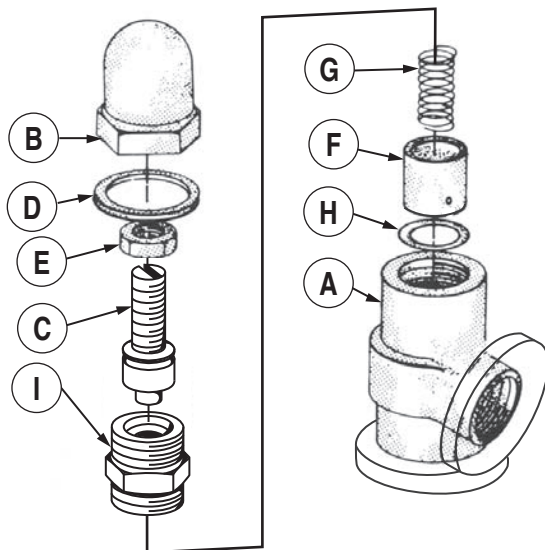

To dismantle valve for inspection cleaning:

1. Remove cap "B"
2. Remove O-Ring "D"
3. Remove lock nut "E"
4. Remove bonnet "I"
5. Remove adjusting screw "C"
6. Remove spring "G"
7. Remove piston "F"
8. Remove stop ring "H" (Not Recommended)  
(Special tooling is required to install new stop ring.)

Inspect valve bore and piston for wear and scoring. Replace broken or damaged parts. Clean all parts thoroughly and re-assemble by reversing the above procedure.

## No Leaking, Dripping, Spills or Venting

The Fulflo FV-Series valve includes a new safer design that prevents liquid and gasses from venting out of the valve during normal operation and adjustment conditions. This valve has been especially designed to prevent the adjusting screw from backing out while making adjustments to the pressure setting. An o-ring has been incorporated around the adjusting screw to further prevent liquid from escaping.

## Operates Efficiently and Effectively

The FV-Series valves can be mounted in any position with sizes ranging from 3/8" through 2", and will operate efficiently with any application or viscosity

at pressures from 2 to 1000 psi. Flange or screw connections are available in brass, cast iron, steel or stainless steel. All parts are completely interchangeable and convertible with other Fulflo V-Series valves.

## Fulflo Valve Advantages

These valves offer Fulflo's patented "chatter-free" performance and are ideally suited for hydraulic and lubricating system protection. All Fulflo valves include a patented modulating piston design with absolute or differential pressure operation. Our advanced modulating operation allows Fulflo valves to be used in many different applications including positive displacement or centrifugal pump and system protection. Fulflo valves can be mounted in any position.

# FV-SERIES

FV-SERIES VALVES

## ASSEMBLY NUMBER IDENTIFICATION CHART

Symbol No.	Designation	Code	Description
1	Series	FV	
2	Material	J B S SS	Cast iron Brass Steel Stainless Steel (300 Series Stainless)
3	Connections	None F	Screw Connections Flange Connections 300# Flange Class Standard (250# Flange Class - Cast Iron Standard)
4	Size	-2 -3 -4 -5 -6 -7 -8	3/8" 1/2" 3/4" 1" 1 1/4" 1 1/2" 2"
5,6,7	ASA Flange Rating	None -150 -600	300# Flange Standard (no designation required)
8	Flange Style 150# & 600# only	A B C D	Raised Face, Staggered Bolt Centers Smooth Face, Staggered Bolt Centers Raised Face, Bolts on Valve Centerline Smooth Face, Bolts on Valve Centerline
9	O-Ring Material	R RV RS RA EPR RN	Buna (Standard) Viton Silicone Aflas Ethylene Propylene Neoprene  (Note: No Teflon O-Rings may be used)
10	Piston Material	/HS /SS /3SS	Hardened Steel 416 Stainless Steel 303 Stainless Steel (For Stainless Valves Only)
11	Spring	/AS /US /WS /XS /YS /ZS	
12	Setting		Desired Set Pressure

### EXAMPLES:

<b>FVJ-5RV/HS/WS</b>						
FV	J	-5	RV	/HS	/WS	
Series	Cast Iron	1"	Viton O-Ring	H.S. Piston	WS Spring	

<b>FVJF-5R/HS/WS</b>						
FV	J	F	-5	R	/HS	/WS
Series	Cast Iron	Flanged	1"	Buna O-Ring	H.S. Piston	WS Spring

<b>FVJF-5-150AR/HS/WS</b>							
FV	J	F	-5	-150	A	R	/HS /WS
Series	Cast Iron	Flanged	1"	Rating	Style	Buna O-Ring	H.S. Piston WS Spring

## STANDARD PRESSURE RANGE CHART

Valve Pipe Size	Valve Flange Size	SPRING PRESSURE AND IDENTIFICATION NO.															
		BLACK-AS		RED-US		GREEN-WS		YELLOW-XS		WHITE-YS		BLUE-ZS		PURPLE-TS		BROWN-RS	
		Low	High	Low	High	Low	High	Low	High	Low	High	Low	High	Low	High	Low	High
3/8"		3	10	7	35	30	100	60	175	150	350	300	500	400	600	550	750
1/2"		3	10	7	35	30	100	60	175	150	350	300	500	400	600	550	750
3/4"		3	10	7	35	30	100	60	175	150	350	300	500				
1"	1"	3	10	7	35	30	100	60	175	150	350	300	500				
1 1/4"	1 1/4"	3	10	7	35	30	100	60	175	150	350	300	500				
1 1/2"	1 1/2"	3	10	7	35	30	100	60	175	150	350	300	500				
2"	2"	3	10	7	35	30	100	60	175	150	350	250	600				

# FV-SERIES

**FVJ** Cast Iron

**FVS** Steel

**FVB** Brass

**FVSS** Stainless Steel

## DIMENSIONS

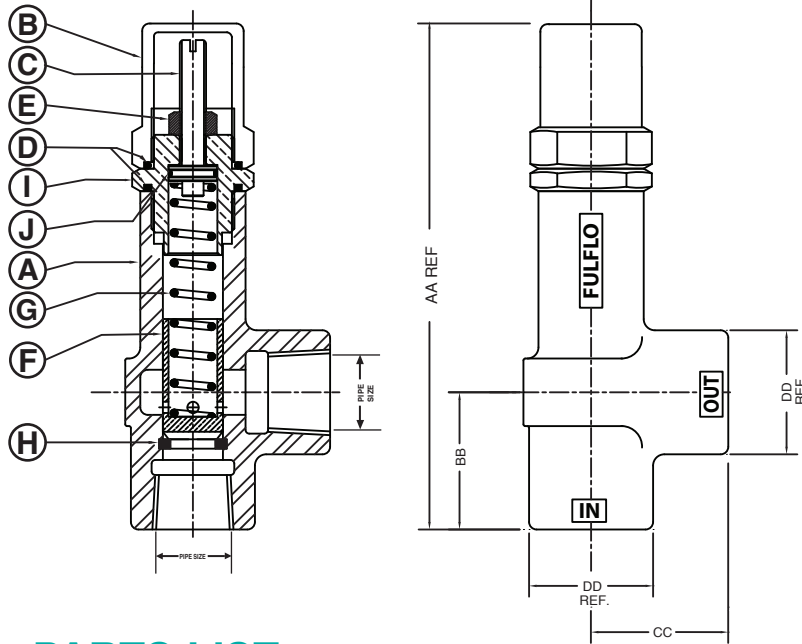

Valve Size	DIMENSIONS IN INCHES			
	AA	BB	CC	DD REF
3/8"	5 <sup>31</sup> / <sub>32</sub>	1 <sup>3</sup> / <sub>8</sub>	1 <sup>3</sup> / <sub>8</sub>	1 <sup>3</sup> / <sub>8</sub>
1/2"	7 <sup>3</sup> / <sub>32</sub>	1 <sup>11</sup> / <sub>16</sub>	1 <sup>7</sup> / <sub>16</sub>	1 <sup>7</sup> / <sub>16</sub>
3/4"	7 <sup>5</sup> / <sub>16</sub>	1 <sup>15</sup> / <sub>16</sub>	1 <sup>13</sup> / <sub>16</sub>	1 <sup>11</sup> / <sub>16</sub>
1"	9 <sup>1</sup> / <sub>32</sub>	2 <sup>9</sup> / <sub>32</sub>	2 <sup>9</sup> / <sub>32</sub>	2 <sup>1</sup> / <sub>16</sub>
1 1/4"	10 <sup>1</sup> / <sub>16</sub>	2 <sup>9</sup> / <sub>16</sub>	2 <sup>9</sup> / <sub>16</sub>	2 <sup>1</sup> / <sub>2</sub>
1 1/2"	12 <sup>15</sup> / <sub>32</sub>	2 <sup>11</sup> / <sub>16</sub>	2 <sup>11</sup> / <sub>16</sub>	2 <sup>7</sup> / <sub>8</sub>
2"	13 <sup>3</sup> / <sub>4</sub>	3	3	3 <sup>1</sup> / <sub>4</sub>

## PARTS LIST

SYM.	NAME	MODEL	VALVE SIZE						
			3/8"	1/2"	3/4"	1"	1 1/4"	1 1/2"	2"
A	BODY	FVJ	200	300	400	500	600	700	800
		FVB	200-B	300-B	400-B	500-B	600-B	700-B	800-B
		FVS	200-S	300-S	400-S	500-S	600-S	700-S	800-S
		FVSS	200-SS	300-SS	400-SS	500-SS	600-SS	700-SS	800-SS
B	CAP	FVJ	201-SR	301-SR	401-R	501-R	601-R	701-R	801-R
		FVB	201-BR	301-BR	401-BR	501-BR	601-BR	701-BR	801-BR
		FVS	201-SR	301-SR	401-SR	501-SR	601-SR	701-SR	801-SR
		FVSS	201-SSR	301-SSR	401-SSR	501-SSR	601-SSR	701-SSR	801-SSR
C	ADJUSTING SCREW	FVJ	202-S8	302-S8	402-S8	502-S8	602-S8	702-S8	802-S8
		FVB	202-B8	302-B8	402-B8	502-B8	602-B8	702-B8	802-B8
		FVS	202-S8	302-S8	402-S8	502-S8	602-S8	702-S8	802-S8
		FVSS	202-SS8	302-SS8	402-SS8	502-SS8	602-SS8	702-SS8	802-SS8
D	O-RING † (2 REQUIRED)	FVJ	204-*	304-*	404-*	504-*	604-*	704-*	804-*
		FVB	204-*	304-*	404-*	504-*	604-*	704-*	804-*
		FVS	204-*	304-*	404-*	504-*	604-*	704-*	804-*
		FVSS	204-*	304-*	404-*	504-*	604-*	704-*	804-*
E	LOCK NUT	FVJ	205-S	305-S	305-S	505-S	505-S	505-S	505-S
		FVB	205-S	305-S	305-S	505-S	505-S	505-S	505-S
		FVS	205-S	305-S	305-S	505-S	505-S	505-S	505-S
		FVSS	205-SS	305-SS	305-SS	505-SS	505-SS	505-SS	505-SS
F	PISTON †	HARDENED STEEL	206	306	406	506	606	706	806
		416 STAINLESS STEEL	206-A	306-A	406-A	506-A	606-A	706-A	806-A
		303 STAINLESS STEEL	206-SS	306-SS	406-SS	506-SS	606-SS	706-SS	806-SS
G	SPRING †	ALL MODELS	207-**	307-**	407-**	507-**	607-**	707-**	807-**
H	STOP RING	FVJ	208-S	308-S	408-S	508-S	608-S	708-S	808-S
		FVB	208-B	308-B	408-B	508-B	608-B	708-B	808-B
		FVS	208-S	308-S	408-S	508-S	608-S	708-S	808-S
		FVSS	208-SS	308-SS	408-SS	508-SS	608-SS	708-SS	808-SS
I	BONNET	FVJ	223-S4	323-S4	423-S4	523-S4	623-S4	723-S4	823-S4
		FVB	223-B4	323-B4	423-B4	523-B4	623-B4	723-B4	823-B4
		FVS	223-S4	323-S4	423-S4	523-S4	623-S4	723-S4	823-S4
		FVSS	223-SS4	323-SS4	423-SS4	523-SS4	623-SS4	723-SS4	823-SS4
J	O-RING † (1 REQUIRED)	FVJ	7058-*	7006-*	7025-*	7003-*	7061-*	7062-*	504-*
		FVB	7058-*	7006-*	7025-*	7003-*	7061-*	7062-*	504-*
		FVS	7058-*	7006-*	7025-*	7003-*	7061-*	7062-*	504-*
		FVSS	7058-*	7006-*	7025-*	7003-*	7061-*	7062-*	504-*

\* See o-ring selection chart

\*\* See spring pressure chart

† Recommended spare parts

# FV-SERIES

**FVJF** Cast Iron    **FVSF** Steel  
**FVBF** Brass        **FVSSF** Stainless Steel

## DIMENSIONS

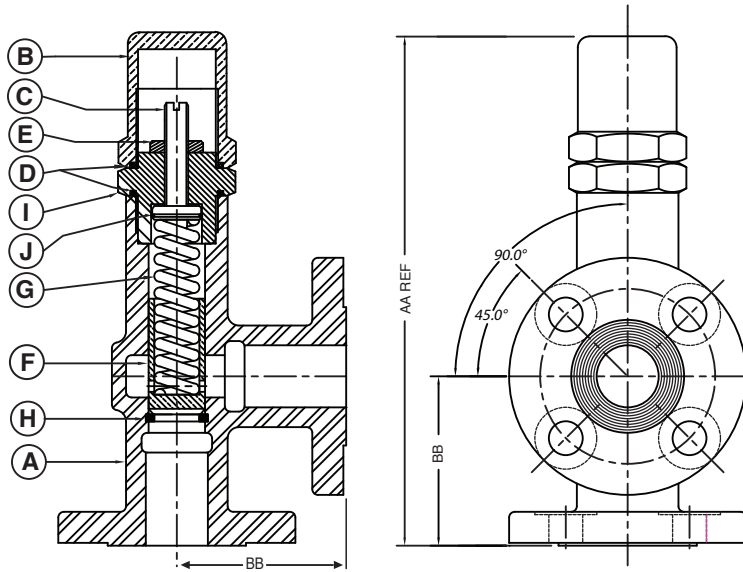

### DIMENSIONS IN INCHES

Valve Size	AA	BB
1"	10 <sup>5</sup> / <sub>16</sub> "	3 <sup>1</sup> / <sub>2</sub> "
1 <sup>1</sup> / <sub>4</sub> "	11 <sup>13</sup> / <sub>16</sub> "	3 <sup>3</sup> / <sub>4</sub> "
1 <sup>1</sup> / <sub>2</sub> "	12 <sup>5</sup> / <sub>8</sub> "	4 <sup>1</sup> / <sub>16</sub> "
2"	15 <sup>5</sup> / <sub>16</sub> "	4 <sup>9</sup> / <sub>16</sub> "

Note: Dimensions reflect 150# and 300# only

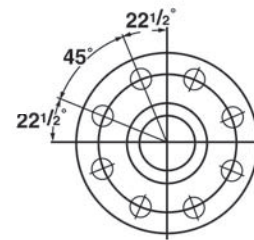

FOR 2" VALVE ONLY

## PARTS LIST

SYM.	NAME	MODEL	VALVE SIZE			
			1"	1 <sup>1</sup> / <sub>4</sub> "	1 <sup>1</sup> / <sub>2</sub> "	2"
A	BODY	FVJF FVBF FVSF FVSSF	500-F 500-BF 500-SF 500-SSF	600-F 600-BF 600-SF 600-SSF	700-F 700-BF 700-SF 700-SSF	800-F 800-BF 800-SF 800-SSF
B	CAP	FVJF FVBF FVSF FVSSF	501-R 501-BR 501-SR 501-SSR	601-R 601-BR 601-SR 601-SSR	701-R 701-BR 701-SR 701-SSR	801-R 801-BR 801-SR 801-SSR
C	ADJUSTING SCREW	FVJF FVBF FVSF FVSSF	502-S8 502-B8 502-S8 502-SS8	602-S8 602-B8 602-S8 602-SS8	702-S8 702-B8 702-S8 702-SS8	802-S8 802-B8 802-S8 802-SS8
D	O-RING † (2 REQUIRED)	FVJF FVBF FVSF FVSSF	504- 504- 504- 504-*	604- 604- 604- 604-*	704- 704- 704- 704-*	804- 804- 804- 804-*
E	LOCK NUT	FVJF FVBF FVSF FVSSF	505-S 505-S 505-S 505-SS	505-S 505-S 505-S 505-SS	505-S 505-S 505-S 505-SS	505-S 505-S 505-S 505-SS
F	PISTON †	HARDENED STEEL 416 STAINLESS STEEL 303 STAINLESS STEEL	506 506-A 506-SS	606 606-A 606-SS	706 706-A 706-SS	806 806-A 806-SS
G	SPRING †	ALL MODELS	507-**	607-**	707-**	807-**
H	STOP RING	FVJF FVBF FVSF FVSSF	508-S 508-B 508-S 508-SS	608-S 608-B 608-S 608-SS	708-S 708-B 708-S 708-SS	808-S 808-B 808-S 808-SS
I	BONNET	FVJF FVBF FVSF FVSSF	523-S4 523-B4 523-S4 523-SS4	623-S4 623-B4 623-S4 623-SS4	723-S4 723-B4 723-S4 723-SS4	823-S4 823-B4 823-S4 823-SS4
J	O-RING † (1 REQUIRED)	FVJF FVBF FVSF FVSSF	7003- 7003- 7003- 7003-*	7061- 7061- 7061- 7061-*	7062- 7062- 7062- 7062-*	504- 504- 504- 504-*

\* See o-ring selection chart

\*\* See spring pressure chart

† Recommended spare parts

# FV-SERIES

All valve tests 110° F. to 120° F. Oil Viscosity 150 S.S.U. at 100° F.  
(Charts good from 30 to 500 S.S.U.)

3/8" VALVE TESTS

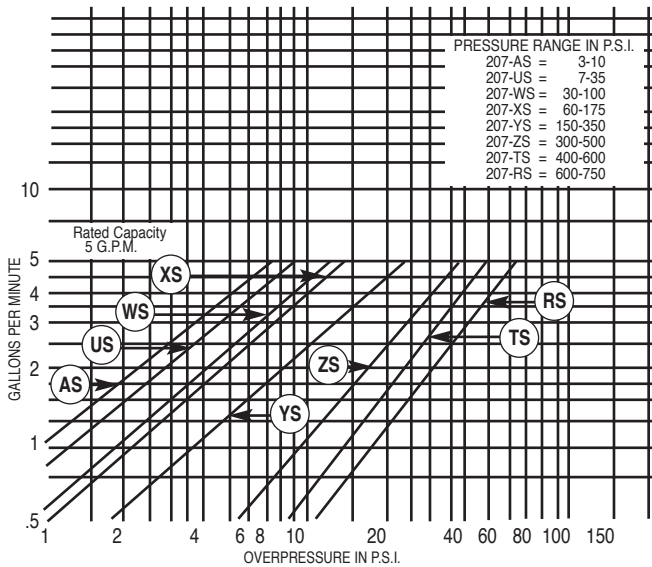

1/2" VALVE TESTS

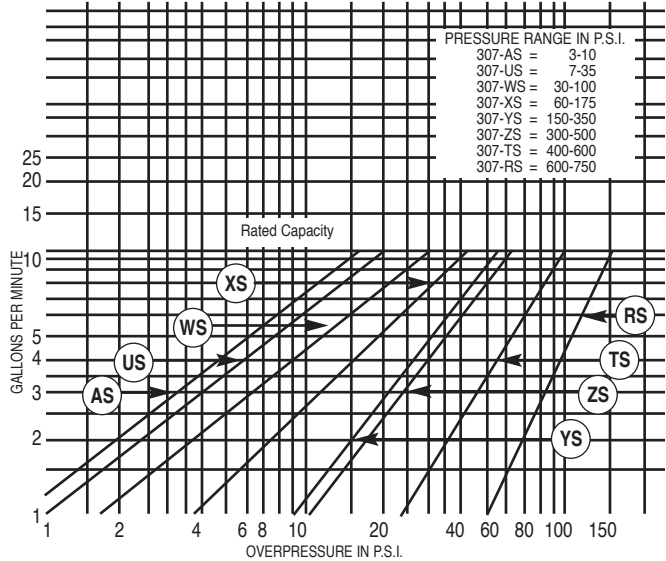

3/4" VALVE TESTS

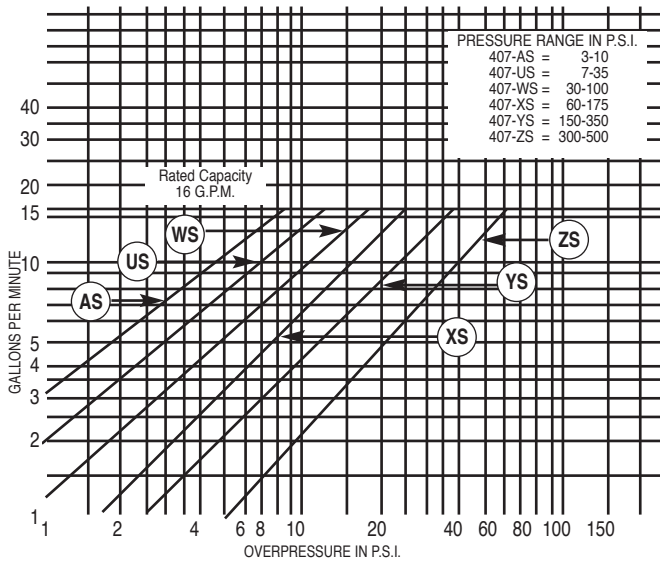

1" VALVE TESTS

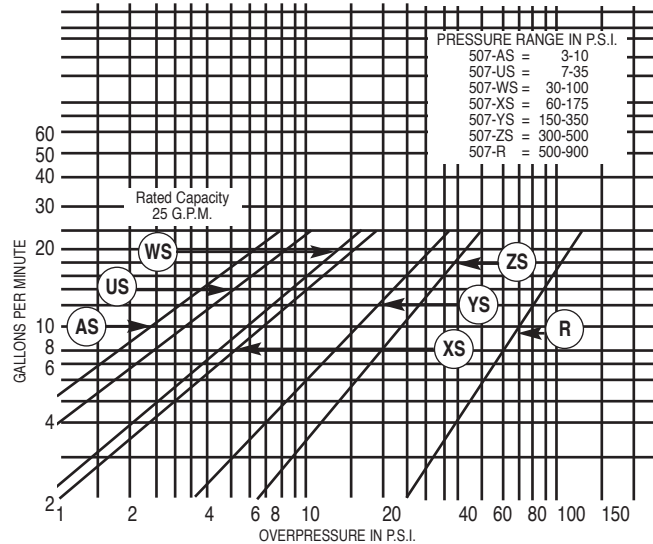

**Overpressure** - The pressure increase or accumulation above the set pressure when the valve is discharging flow.



# FV-SERIES

All valve tests 110°F. to 120°F. Oil Viscosity 150 S.S.U. at 100°F.  
(Charts good from 30 to 500 S.S.U.)

FV-SERIES  
VALVES

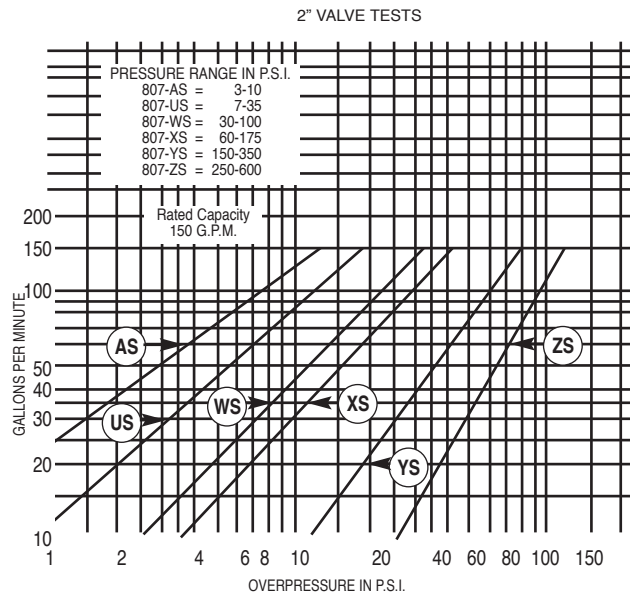
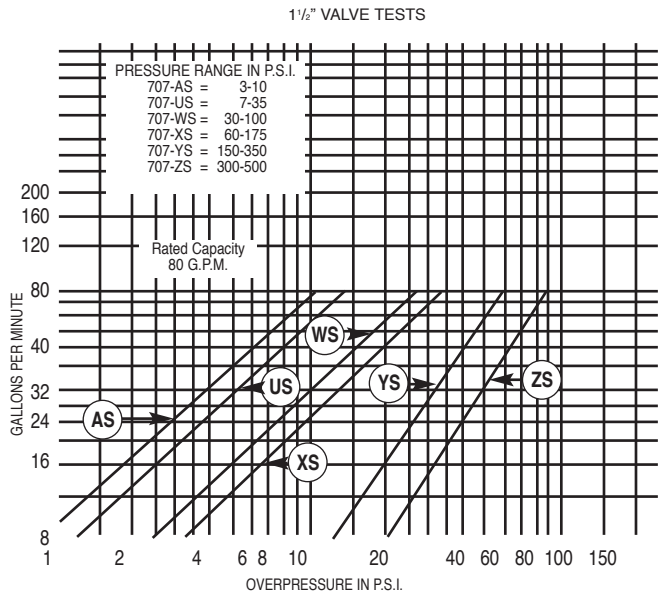
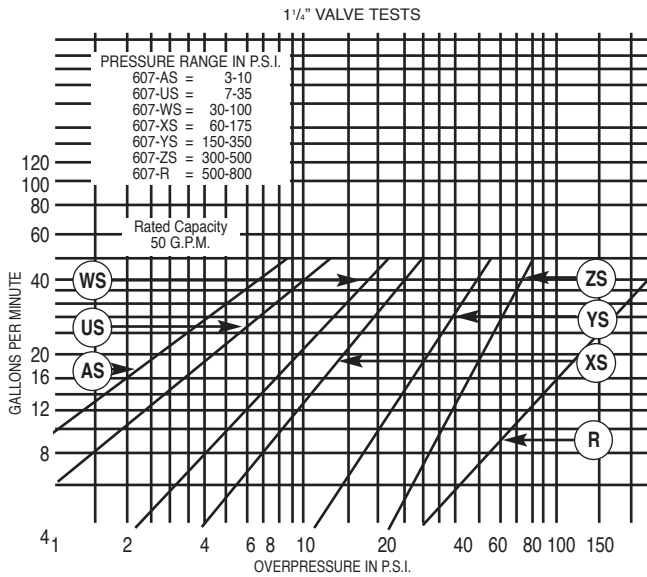

**Overpressure** - The pressure increase or accumulation above the set pressure when the valve is discharging flow.

# OV-SERIES VALVES

## Installation, Maintenance & Operating Instructions



Standard  
with Screw  
Connections

Standard  
with Flange  
Connections

Stainless Steel  
with Screw  
Connections

*Note: OV-Series Valves offered in Cast Iron, Brass, Steel and Stainless Steel*

### APPLICATION

The OV-Series valve is a "Relief Valve" (RV) in a sense that the outlet pressure doesn't affect the valve's set pressure. The valves operate off the inlet pressures only. The OV-Series valve is to be used when you don't want the backpressure to affect the valves opening pressure. The valve sizes from 1/2" to 2" operate efficiently with liquids of any viscosity at pressures from 10 to 500 P.S.I.

Available in screwed connection and flange, in a choice of brass, cast iron, steel or stainless steel. Widely used in a variety of applications, the OV-Series valves are ideally suited for all hydraulic and lubricating systems for pressure regulation and system protection. Special requirements should be referred to our engineering staff for recommendations.

### INSTALLATION

Fulflo valves can be mounted in any position. A tee may be inserted in the pump discharge line to mount the valve. The correct size of valve should be installed, preferably matching the pump discharge line. Screw the valve into the nipple in the tee, or in the case of the flange style, bolt the valve to the companion flange screwed into the nipple. When the valve is used for frequent bypassing of oil pressure, its outlet

should be piped back to the tank. Care must be taken to have the discharge well below the oil level in the tank to prevent air entrainment and erratic operation.

Only if the valve is used as safety or overload relief and operates infrequently may its discharge be piped back into the pump suction line. Frequent or continuous operation under these conditions will cause excessive heating of the oil and possible damage.

# OV-SERIES

## SETTING VALVES

Valves may be set with a hydraulic hand pump for cracking pressure. If a test stand is available, valve should be connected to the discharge header with the pump bypass open, and the bypass gradually closed until the desired pressure registers on the gauge. Adjust valve adjusting screw until valve slightly bleeds at the set bypass pressure and lock adjusting screw.

Fulflo valves are not designed to be positive shut-off, and will pass a minimal amount of leakage before the set pressure. If a valve is required to bypass a given amount of fluid at a given pressure, a test stand

having a flow meter in the pump discharge line must be available. With a valve adjusted for cracking pressure as above, continue closing bypass until the required flow registers on the flow meter and observe pressure. Readjust pressure, if necessary, to obtain desired pressure at desired flow.

## MAINTENANCE

Fulflo valves provide reliable “chatter-free” operation when the system is free of abrasives and foreign matter. Continuous filtration of the liquid used is strongly recommended.

## TYPICAL DISASSEMBLY

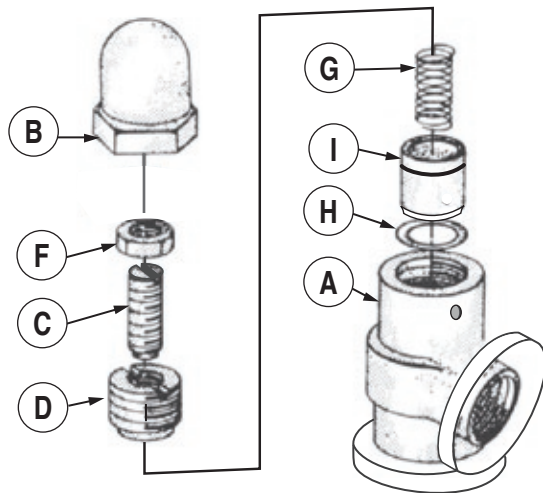

To dismantle valve for inspection or cleaning:

1. Remove cap “B”
2. Remove lock nut “F”
3. Remove adjusting screw “C”
4. Remove retainer “D”
5. Remove spring “G”
6. Remove piston “I”
7. Remove stop ring “H” (Not Recommended)  
(Special tooling is required to install new stop ring.)

Inspect valve bore and piston for wear and scoring. Replace broken or damaged parts. Clean all parts thoroughly and re-assemble by reversing the above procedure.

## TYPICAL APPLICATIONS

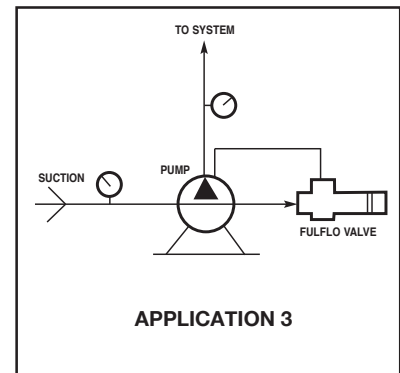
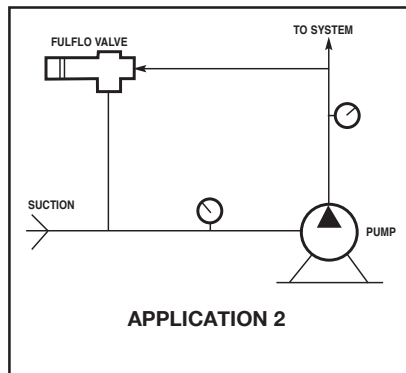
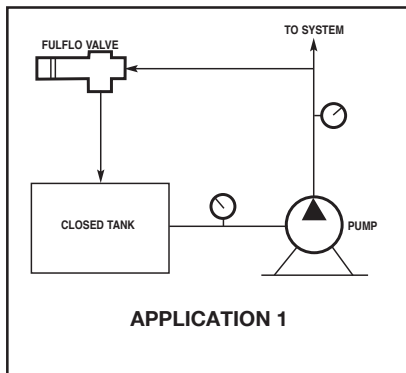

# OV-SERIES

## ASSEMBLY NUMBER IDENTIFICATION CHART

Symbol No.	Designation	Code	Description
1	Style	None	Standard Model
2	Series	OV	
3	Material	J B S SS	Cast iron Brass Steel Stainless Steel (300 Series Stainless)
4	Connections	None F	Screw Connections Flange Connections 300# Flange Class Standard (250# Flange Class - Cast Iron Standard)
5	Size	-3 -4 -5 -6 -7 -8	1/2" 3/4" 1" 1 1/4" 1 1/2" 2"
6,7,8	ASA Flange Rating	None -150 -600	300# Flange Standard (no designation required)
9	Flange Style 150# & 600# Only	A B C D	Raised Face, Staggered Bolt Centers Smooth Face, Staggered Bolt Centers Raised Face, Bolts on Valve Centerline Smooth Face, Bolts on Valve Centerline
10	O-Ring Material	R RV RS RA EPR RN	Buna (standard) Viton Silicone Aflas Ethylene Propylene Neoprene  (Note: No Teflon O-Rings may be used)
11	Options	SP	Steel Parts <i>(used on cast iron valves only)</i>
12	Piston Material	/HS /SS /3SS	Hardened Steel 416 Stainless Steel 303 Stainless Steel (For Stainless Valves Only)
13	Spring	/WS /XS /YS /ZS	
14	Setting		Desired Set Pressure

### EXAMPLES:

<b>OVJ-5RVSP/HS/WS</b>							
OV	J	-5	RV	SP	/HS	/WS	
Series	Cast Iron	1"	Viton O-Ring	Steel Parts	H.S. Piston	WS Spring	

<b>OVJF-5R/HS/WS</b>							
OV	J	F	-5	R	/HS	/WS	
Series	Cast Iron	Flanged	1"	Buna O-Ring	H.S. Piston	WS Spring	

<b>OVJF-5-150AR/HS/WS</b>									
OV	J	F	-5	-150	A	R	/HS	/WS	
Series	Cast Iron	Flanged	1"	Rating	Style	Buna O-Ring	H.S. Piston	WS Spring	

## STANDARD PRESSURE RANGE CHART

Valve Pipe Size	Valve Flange Size	SPRING PRESSURE AND IDENTIFICATION NO.							
		GREEN-WS		YELLOW-XS		WHITE-YS		BLUE-ZS	
		Low	High	Low	High	Low	High	Low	High
1/2"		40	100	75	150	150	300	250	500
3/4"		30	80	70	140	130	250	150	450
1"	1"	10	50	25	100	40	150	125	300
1 1/4"	1 1/4"	10	50	25	100	40	150	125	300
1 1/2"	1 1/2"	30	100	60	175	150	350	300	500
2"	2"	30	100	60	175	150	350	300	500

+/-1-5 PSI ON ALL SPRING RANGES

# OV-SERIES

**OVJ** Cast Iron    **OVB** Brass

**OVS** Steel

**OVSS** Stainless Steel

**OVJ-SP** Cast Iron with Steel Parts

## DIMENSIONS

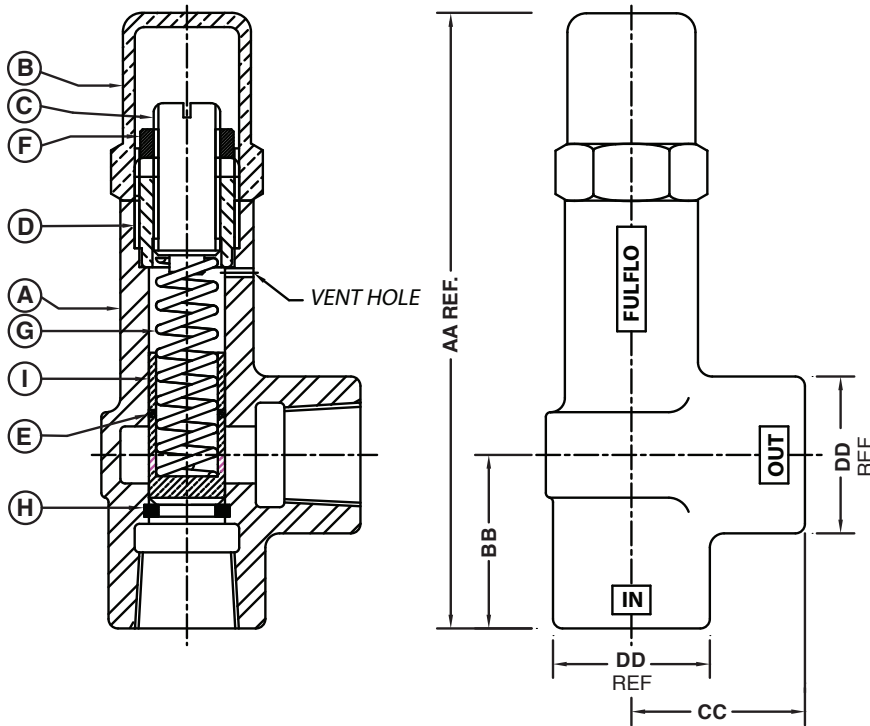

Valve Size	DIMENSIONS IN INCHES			
	AA	BB	CC	DD REF
3/8"	5 <sup>11</sup> / <sub>32</sub>	1 <sup>3</sup> / <sub>8</sub>	1 <sup>3</sup> / <sub>8</sub>	1 <sup>3</sup> / <sub>8</sub>
1/2"	6 <sup>9</sup> / <sub>16</sub>	1 <sup>11</sup> / <sub>16</sub>	1 <sup>7</sup> / <sub>16</sub>	1 <sup>7</sup> / <sub>16</sub>
3/4"	6 <sup>15</sup> / <sub>16</sub>	1 <sup>15</sup> / <sub>16</sub>	1 <sup>13</sup> / <sub>16</sub>	1 <sup>11</sup> / <sub>16</sub>
1"	8 <sup>7</sup> / <sub>32</sub>	2 <sup>9</sup> / <sub>32</sub>	2 <sup>9</sup> / <sub>32</sub>	2 <sup>1</sup> / <sub>16</sub>
1 1/4"	9 <sup>9</sup> / <sub>16</sub>	2 <sup>9</sup> / <sub>16</sub>	2 <sup>9</sup> / <sub>16</sub>	2 <sup>1</sup> / <sub>2</sub>
1 1/2"	11 <sup>1</sup> / <sub>16</sub>	2 <sup>11</sup> / <sub>16</sub>	2 <sup>11</sup> / <sub>16</sub>	2 <sup>7</sup> / <sub>8</sub>
2"	13	3	3	3 <sup>1</sup> / <sub>4</sub>

## PARTS LIST

SYM.	NAME	MODEL	VALVE SIZE					
			1/2"	3/4"	1"	1 1/4"	1 1/2"	2"
A	BODY	OVJ, OVJ-SP OVB OVS OVSS	300-33 300-B33 300-S33 300-SS33	400-26 400-B26 400-S26 400-SS26	500-39 500-B39 500-S39 500-SS39	600-25 600-B25 600-S25 600-SS25	700-27 700-B27 700-S27 700-SS27	800-30 800-B30 800-S30 800-SS30
B	CAP	OVJ, OVJ-SP OVB OVS OVSS	301-S 301-B 301-S 301-SS	401 401-B 401-S 401-SS	501 501-B 501-S 501-SS	601 601-B 601-S 601-SS	701 701-B 701-S 701-SS	801 801-B 801-S 801-SS
C	ADJUSTING SCREW	OVJ, OVB OVS, OVJ-SP OVSS	302-B 302-S 302-SS	402-B 402-S 402-SS	502-B 502-S 502-SS	602-B 602-S 602-SS	702-B 702-S 702-SS	802-B 802-S 802-SS
D	RETAINER	OVJ, OVB OVS, OVJ-SP OVSS	303-B 303-S 303-SS	403-B 403-S 403-SS	503-B 503-S 503-SS	603-B 603-S 603-SS	703-B 703-S 703-SS	803-B 803-S 803-SS
E	PISTON O-RING †	OVJ, OVJ-SP, OVB, OVS OVSS	224-*	424-*	204-*	7073-*	7069-*	7069-*
F	LOCK NUT	OVJ, OVJ-SP, OVS, OVB OVSS	305-S 305-SS	405-S 405-SS	505-S 505-SS	605-S 605-SS	705-S 705-SS	805-S 805-SS
G	SPRING †	ALL MODELS	207-**	307-**	407-**	507-**	607-**	707-**
H	STOP RING	OVJ, OVB OVS, OVJ-SP OVSS	308-B 308-S 308-SS	408-B 408-S 408-SS	508-B 508-S 508-SS	608-B 608-S 608-SS	708-B 708-S 708-SS	808-B 808-S 808-SS
I	PISTON †	HARDENED STEEL 416 STAINLESS STEEL 303 STAINLESS STEEL	306-21 306-A21 306-SS21	406-22 406-A22 406-SS22	506-32 506-A32 506-SS32	606-32 606-A32 606-SS32	706-25 706-A25 706-SS25	806-23 806-A23 806-SS23

\* See o-ring selection chart

\*\* See spring pressure chart

† Recommended spare parts



# OV-SERIES

**OVJF** Cast Iron

**OVSF** Steel

**OVBF** Brass

**OVSSF** Stainless Steel

**OVJF-SP** Cast Iron with Steel Parts

## DIMENSIONS

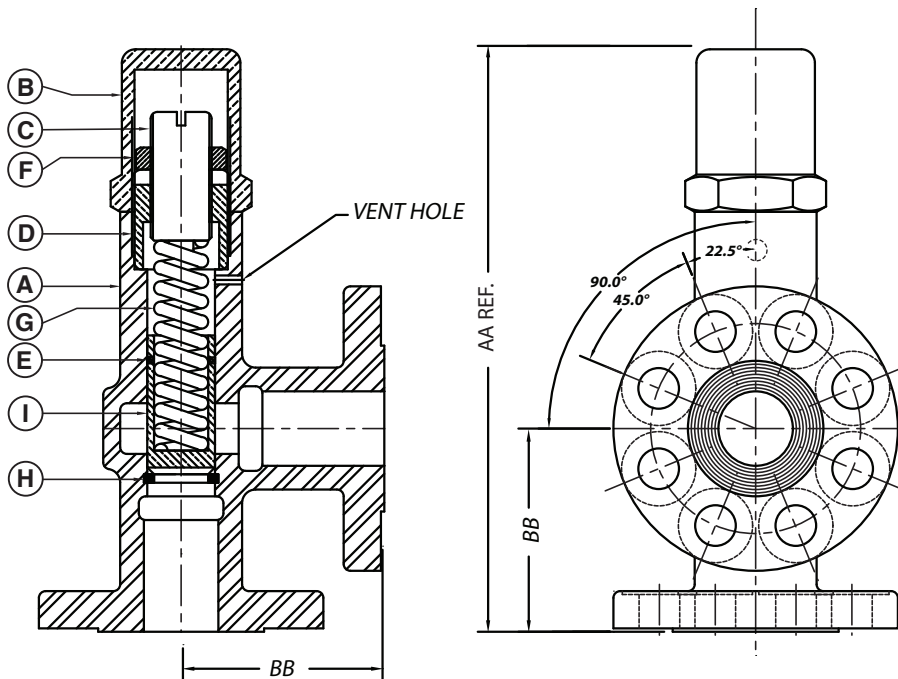

### DIMENSIONS IN INCHES

Valve Size	AA	BB
1"	9 <sup>1</sup> / <sub>2</sub> "	3 <sup>1</sup> / <sub>2</sub> "
1 <sup>1</sup> / <sub>4</sub> "	10 <sup>13</sup> / <sub>16</sub> "	3 <sup>3</sup> / <sub>4</sub> "
1 <sup>1</sup> / <sub>2</sub> "	12 <sup>7</sup> / <sub>16</sub> "	4 <sup>1</sup> / <sub>16</sub> "
2"	14 <sup>9</sup> / <sub>16</sub> "	4 <sup>9</sup> / <sub>16</sub> "

Note: Dimensions reflect 150# and 300# only

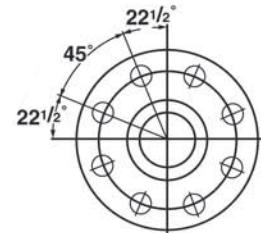

FOR 2" VALVE ONLY

## PARTS LIST

SYM.	NAME	MODEL	VALVE SIZE			
			1"	1 <sup>1</sup> / <sub>4</sub> "	1 <sup>1</sup> / <sub>2</sub> "	2"
A	BODY	OVJF, OVJF-SP OVBF OVSF OVSSF	500-F39 500-BF39 500-SF39 500-SSF39	600-F25 600-BF25 600-SF25 600-SSF25	700-F27 700-BF27 700-SF27 700-SSF27	800-F30 800-BF30 800-SF30 800-SSF30
B	CAP	OVJF, OVJF-SP OVBF OVSF OVSSF	501 501-B 501-S 501-SS	601 601-B 601-S 601-SS	701 701-B 701-S 701-SS	801 801-B 801-S 801-SS
C	ADJUSTING SCREW	OVJF, OVBF OVSF, OVJF-SP OVSSF	502-B 502-S 502-SS	602-B 602-S 602-SS	702-B 702-S 702-SS	802-B 802-S 802-SS
D	RETAINER	OVJF, OVBF OVSF, OVJF-SP OVSSF	503-B 503-S 503-SS	603-B 603-S 603-SS	703-B 703-S 703-SS	803-B 803-S 803-SS
E	PISTON † O-RING †	OVJF, OVJF-SP OVBF, OVSF OVSSF	204*	7073*	7069*	7069*
F	LOCK NUT	OVJF, OVJF-SP OVSF, OVBF OVSSF	505-S 505-S 505-SS	605-S 605-S 605-SS	705-S 705-S 705-SS	805-S 805-S 805-SS
G	SPRING †	ALL MODELS	407**	507**	607**	707**
H	STOP RING	OVJF, OVBF OVJF-SP, OVSF OVSSF	508-B 508-S 508-SS	608-B 608-S 608-SS	708-B 708-S 708-SS	808-B 808-S 808-SS
I	PISTON †	HARDENED STEEL 416 STAINLESS STEEL 303 STAINLESS STEEL	506-32 506-A32 506-SS32	606-32 606-A32 606-SS32	706-25 706-A25 706-SS25	806-23 806-A23 806-SS23

\* See o-ring selection chart  
 \*\* See spring pressure chart  
 † Recommended spare parts

# OV-SERIES PERFORMANCE CHARTS

All valve tests 110°F. to 120°F. Oil Viscosity 150 S.S.U. at 100°F.  
(Charts good from 30 to 500 S.S.U.)

1/2" VALVE TESTS

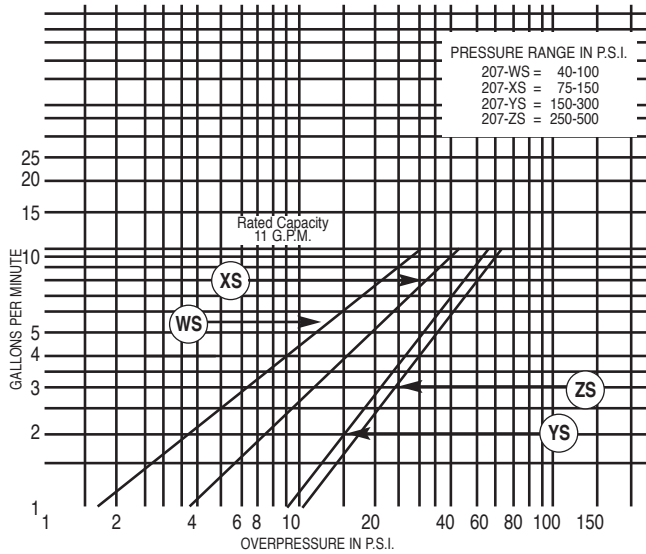

3/4" VALVE TESTS

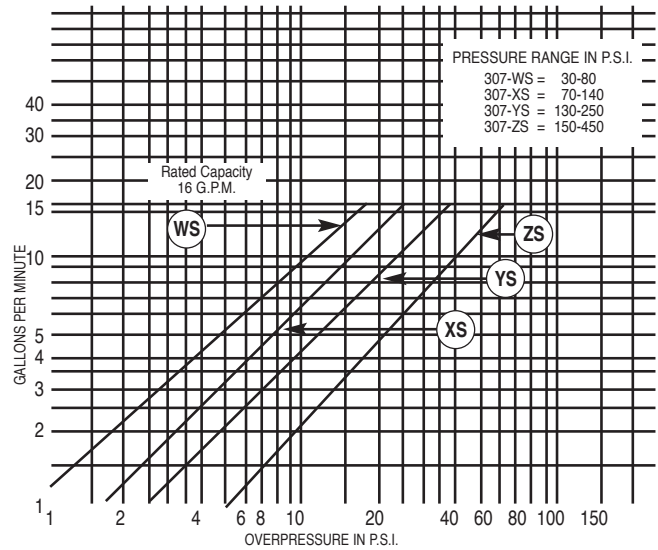

1" VALVE TESTS

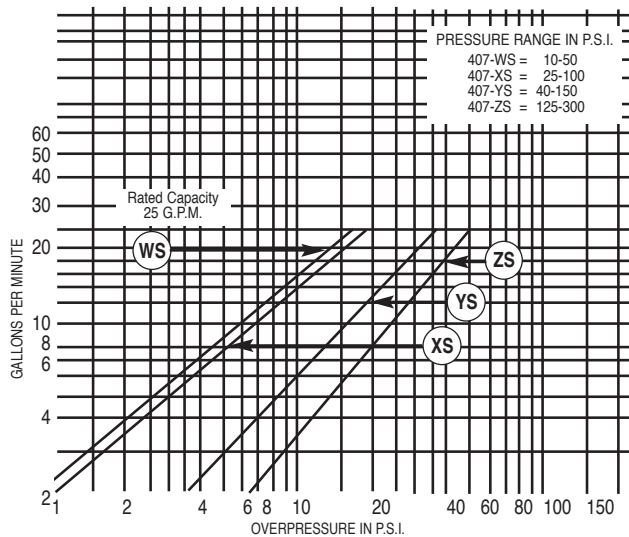

**Overpressure** - The pressure increase or accumulation above the set pressure when the valve is discharging flow.

# OV-SERIES PERFORMANCE CHARTS

All valve tests 110°F. to 120°F. Oil Viscosity 150 S.S.U. at 100°F.  
(Charts good from 30 to 500 S.S.U.)

1 1/4" VALVE TESTS

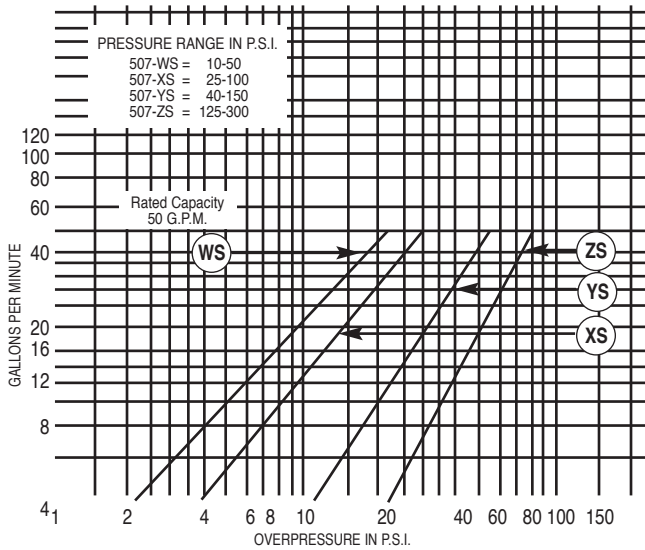

1 1/2" VALVE TESTS

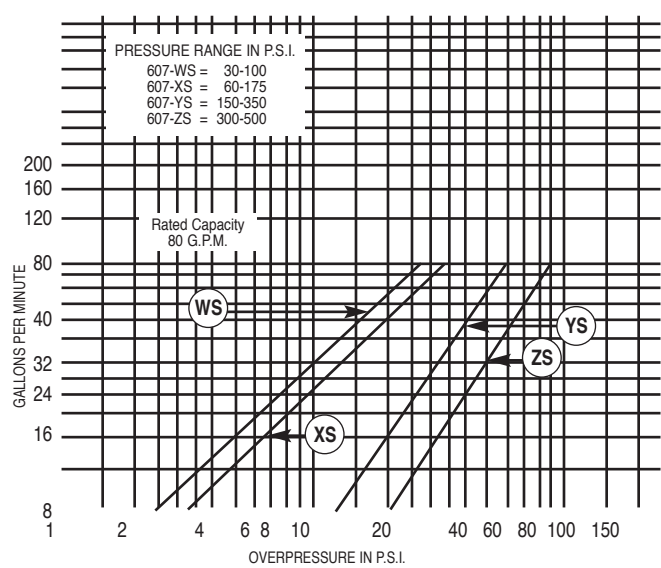

2" VALVE TESTS

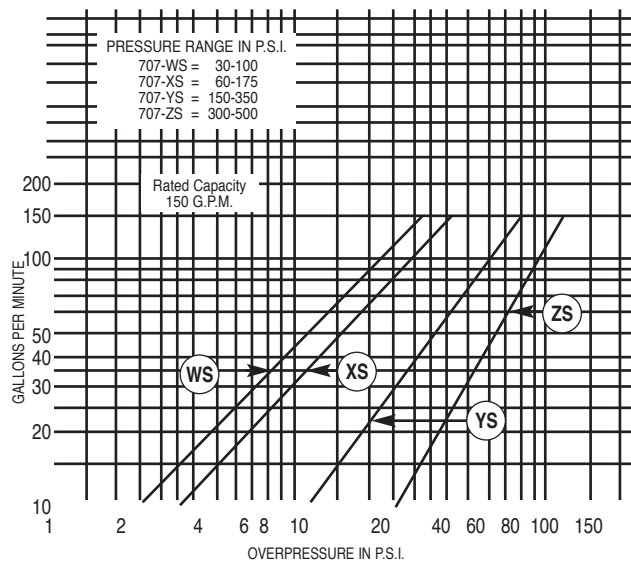

**Overpressure** - The pressure increase or accumulation above the set pressure when the valve is discharging flow.

# A-SERIES VALVES

## Installation, Maintenance & Operating Instructions



### APPLICATION

The Fulflo A-Series feature both direct acting and internal pilot operated models with either screw or flange type connections. The threaded valves are available in both 2½" and 3" sizes in either cast iron or steel. The flange type valves also include a 4" model and may be specified with 150#, 300# or 600# ANSI flanges. Note that 600# is available in Steel and SS only.

The direct acting valves operate at pressures to 150 P.S.I.; the internal pilot operated models at

pressures to 500 P.S.I. Both types handle large flows of liquid of all viscosities encountered in industrial practice.

The A-Series valves may be used in a variety of applications including hydraulic and lubrication systems for load regulation and system protection.

Unusual applications and special valves should be referred to our engineering staff for recommendation.

### INSTALLATION

Fulflo valves can be mounted in any position. A tee may be inserted in the pump discharge line to mount the valve. The pipe lines carrying the heavy valves must be well supported and overhung weights avoided. The correct size of valve must be used, preferably equal to the size of the pipe line to which they are connected. Threaded valves (AAD and ACD) may be

threaded into pipe nipples. Overhung weights on threads should be avoided. Flanged valves (AADF and ACDF) are bolted to the companion flange which may be threaded or welded to the pipe. The outlet of the valve should be piped to the supply tank, unless specific applications call for alternate piping of return lines. Care must be taken to have the discharge well below the oil level in the tank to prevent air entrainment and erratic operation.

# A-SERIES

## SETTING VALVES

Valve may be set with a hydraulic hand pump for cracking pressure. If a test stand is available, valve should be connected to the discharge header with the pump bypass open, and the bypass gradually closed until the desired pressure registers on the gauge. **“Direct”** Adjust valve adjusting screw until valve slightly bleeds at the set bypass pressure and lock adjusting screw. **“Pilot”** Adjust valve adjusting screw until approximately 5-7 GPM is flowing through the valve, at that point the main piston will open and then the valve will be considered at the set point, then lock adjusting screw. If a valve is required to bypass a given amount of fluid at a given

pressure, a test stand having a flow meter in the pump discharge line must be available. With a valve adjusting for cracking pressure as above, continue closing bypass until the required flow registers on the flow meter and observe pressure. Readjust pressure, if necessary, to obtain desired pressure at desired flow.

## MAINTENANCE

Fulflo valves provide reliable “chatter-free” operation when the system is free of abrasives and foreign matter. Continuous filtration of the liquid used is strongly recommended.

## DISASSEMBLY OF DIRECT ACTING VALVES

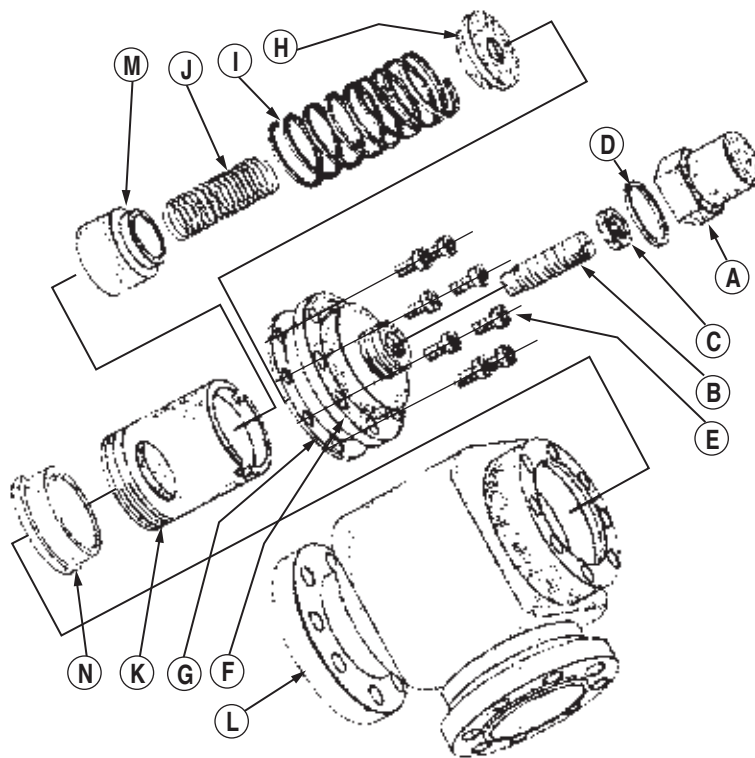

To dismantle the valve for inspection or cleaning:

1. Remove cap “A” and O-ring “D”
2. Remove lock nut “C”
3. Remove adjusting screw “B”
4. Remove cap screws “E”
5. Remove bonnet “F”
6. Remove gasket “G”
7. Remove spring retainer “H”
8. Remove spring or springs “I” and “J”
9. Remove piston “M”
10. Unscrew and withdraw cylinder “K”

11. Remove retaining bushing “N” if necessary

Inspect cylinder bore and piston for wear or scoring. Replace broken or damaged parts. Clean all parts thoroughly and re-assemble as follows:

Reverse process of disassembly from operation 11 to 6, then thread adjusting screw “B” into bonnet “F” so that it may be guided into the recess of spring retainer “H”, while re-assembling bonnet “F” to body “L”. Then proceed with steps 5, 4, 2, 1, in reverse order.



# A-SERIES ASSEMBLY NUMBER IDENTIFICATION CHART

Symbol No.	Designation	Code	Description
1	Series	A	
2	Material	A C SS	Cast Iron Cast Steel Stainless Steel
3	Type	D P	Direct Acting Internal Pilot Operated
4 & 5	Size	09 10 11	2 1/2" 3" 4"
6	Connection	None F	Screw Type (2 1/2" and 3" only) Flange
7,8,9	ASA Flange Rating	150# 300# 600#	
10	Flange Style Only	A B C D	Raised Face, Staggered Bolt Centers Smooth Face, Staggered Bolt Centers Raised Face, Bolts on Valve Centerline Smooth Face, Bolts on Valve Centerline
11	O-Ring Material	R RV RS RT RA EPR RN	Buna O-Ring Cap Seal (Standard) Viton O-Ring Cap Seal Silicone O-Ring Cap Seal Teflon O-Ring Cap Seal Aflas O-Ring Cap Seal Ethylene Propylene Neoprene
12	Piston Material	/HS /SS /3SS	Hardened Steel 416 Stainless Steel 303 Stainless Steel (For Stainless Valves Only)
13	Spring	SPRING PART NUMBER	See Below
14	Setting		Desired Set Pressure

## EXAMPLE:

<b>ACP09R</b>				
A	C	P	09	R
Series	Steel	Pilot Operated	2 1/2"	Buna

NOTE: Special valves are prefixed by numbers assigned by the factory.

## EXAMPLE:

Specify:

1. Valve Model Number ( 1-10 )
2. O-Ring Identification Number ( 11 )
3. Piston Material ( 12 )
4. Spring Part Number ( 13 )
5. Spring pressure range or desired pressure setting. ( 14 )

## SERIES "A" VALVES (Direct Acting) PRESSURE RANGE CHART

Valve Size	Symbol	Spring Part No.	Pressure Range
2 1/2"	I	A0960D	7-57 P.S.I.
	I	A0961C	8-75 P.S.I.
	I & J	A0960D and A0970D	14-115 P.S.I.
	I & J	A0961C and A0971C	16-150 P.S.I.
3"	I	A1060D	5-50 P.S.I.
	I	A1061C	5-67 P.S.I.

NOTE: Springs suffixed with "C" are Chrome Vanadium, "D" indicates Stainless Steel. For pressures other than listed, consult factory.

## (Continued)

3"	I & J	A1060D and A1070D	10-100 P.S.I.
	I & J	A1061C A1071C	10-135 P.S.I.
4"	I	A1160D	2-37 P.S.I.
	I & J	A1160D and A1170D	4-75 P.S.I.

## SERIES "A" VALVES (Pilot Operated)

Valve Size	Symbol	Spring Part No.	Pressure Range
2 1/2"	O & J	A0980D and A1190D	50-500 P.S.I.
3"	O & J	A1080D and A1190D	50-500 P.S.I.
4"	O & J	A1181D and A1190D	50-500 P.S.I.

# A-SERIES 2½" and 3"

(Direct Acting)

## DIMENSIONS

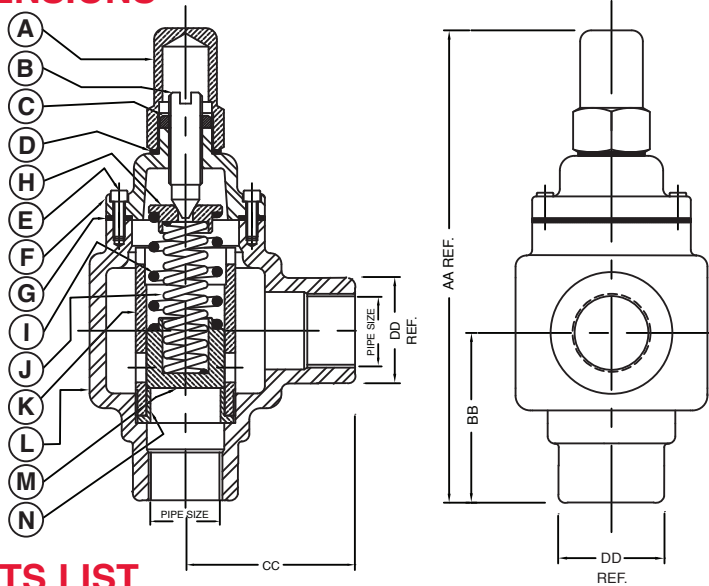

Valve Size	DIMENSIONS IN INCHES			
	AA	BB	CC	DD
2½"	15 <sup>9</sup> / <sub>16</sub>	5½	5 <sup>1</sup> / <sub>16</sub>	4
3"	17 <sup>1</sup> / <sub>2</sub>	6 <sup>5</sup> / <sub>8</sub>	6 <sup>5</sup> / <sub>8</sub>	4

## PARTS LIST

SYMBOL	NAME	MODEL	VALVE SIZE	
			2½"	3"
A	Cap	AA, AC ASS	A1101CR A1101SSR	A1013CR A1013SSR
B	Adjusting Screw	AA, AC ASS	A0922C A0922SS	A1022C A1022SS
C	Lock Nut	AA, AC ASS	605-S 605-SS	705-S 705-SS
D	O-Ring †	AA, AC ASS	604- 604-*	704- 704-*
E	Cap Screw	AA, AC ASS	3/8 x 1 SHCS	3/8 x 1 SHCS
F	Bonnet	AA AC ASS	A0909A A0909C A0909SS	A1009A A1009C A1009SS
G	Gasket †	AA, AC ASS	A0903E A0903RT	A1003E A1003RT
H	Spring Retainer	AA, AC ASS	A0916C A0916SS	A1016C A1016SS
I	Spring †	AA, AC, ASS	See Chart	See Chart
J	Spring †	AA, AC, ASS	See Chart	See Chart
K	Cylinder †	AA, AC ASS	A0908C A0908SS	A1008C A1008SS
L	Body	AA AC ASS	A0900A A0900C A0900SS	A1000A A1000C A1000SS
M	Piston † Hardened Steel 416 Stainless Steel 303 Stainless Steel	AA, AC, AA, AC ASS (only)	A0906C A0906D A0906SS	A1006C A1006D A1006SS
N	Retaining Bushing	AA, AC ASS	A0911C A0911SS	A1011C A1011SS

\*See o-ring selection chart † Recommended spare parts

# A-SERIES 2½", 3" and 4" (Direct Acting)

## DIMENSIONS

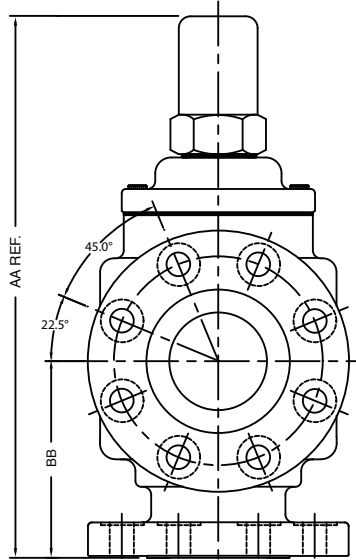
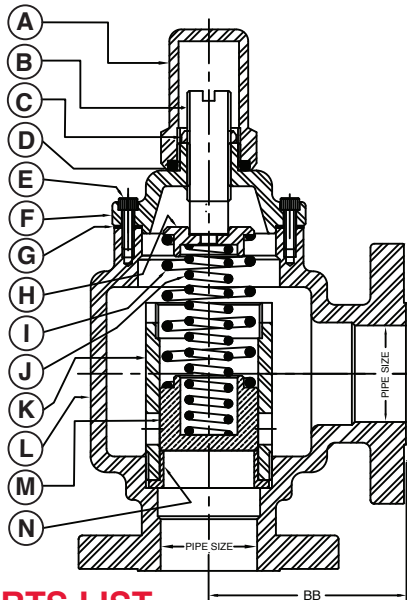

### DIMENSIONS IN INCHES

Valve Size	Flange Rating	AA	BB
2½	150# 300#	15 <sup>13</sup> / <sub>16</sub>	5 <sup>3</sup> / <sub>4</sub>
2½	600#	16 <sup>3</sup> / <sub>16</sub>	6 <sup>1</sup> / <sub>8</sub>
3	150# 300#	17 <sup>1</sup> / <sub>8</sub>	6 <sup>1</sup> / <sub>4</sub>
3	600#	17 <sup>1</sup> / <sub>2</sub>	6 <sup>5</sup> / <sub>8</sub>
4	150# 300#	20	7 <sup>15</sup> / <sub>16</sub>
4	600#	20 <sup>3</sup> / <sub>16</sub>	8 <sup>1</sup> / <sub>8</sub>

Note! Refer to Page 10 for Flange and Drilling Dimensions.

## PARTS LIST

SYMBOL	NAME	MODEL	VALVE SIZE		
			2½"	3"	4"
A	Cap	AA, AC, ASS	A1101CR A1101SSR	A1013CR A1013SSR	A1113CR A1113SSR
B	Adjusting Screw	AA, AC, ASS	A0922C A0922SS	A1022C A1022SS	A1122C A1122SS
C	Lock Nut	AA, AC, ASS	605-S 605-SS	705-S 705-SS	805-S 805-SS
D	O-Ring †	AA, AC, ASS	604- 604-*	704- 704-*	804- 804-*
E	Cap Screw	AA, AC, ASS	3/8 x 1 SHCS	3/8 x 1 SHCS	3/8 x 1 SHCS
F	Bonnet	AA AC ASS	A0909A A0909C A0909SS	A1009A A1009C A1009SS	A1109A A1109C A1109SS
G	Gasket †	AA, AC, ASS	A0903E A0903RT	A1003E A1003RT	A1103E A1103RT
H	Spring Retainer	AA, AC, ASS	A0916C A0916SS	A1016C A1016SS	A1116C A1116SS
I	Spring †	AA, AC, ASS	See Chart	See Chart	See Chart
J	Spring †	AA, AC, ASS	See Chart	See Chart	See Chart
K	Cylinder †	AA, AC, ASS	A0908C A0908SS	A1008C A1008SS	A1108C A1108SS
L	Body	AA AC ASS	A0900AF A0900CF A0900SSF	A1000AF A1000CF A1000SSF	A1100AF A1100CF A1100SSF
M	Piston † Hardened Steel 416-Stainless Steel 303-Stainless Steel	AA AC ASS (Only)	A0906C A0906D A0906SS	A1006C A1006D A1006SS	A1106C A1106D A1106SS
N	Retaining Bushing	AA, AC, ASS	A0911C A0911SS	A1011C A1011SS	A1111C A1111SS

\*See o-ring selection chart

†Recommended spare parts

# A-SERIES PERFORMANCE CHARTS

## (Direct Acting)

All valve tests 110°F. to 120°F. Oil Viscosity 150 S.S.U. at 100°F.  
(Charts good from 30 to 500 S.S.U.)

2 1/2" VALVE TESTS

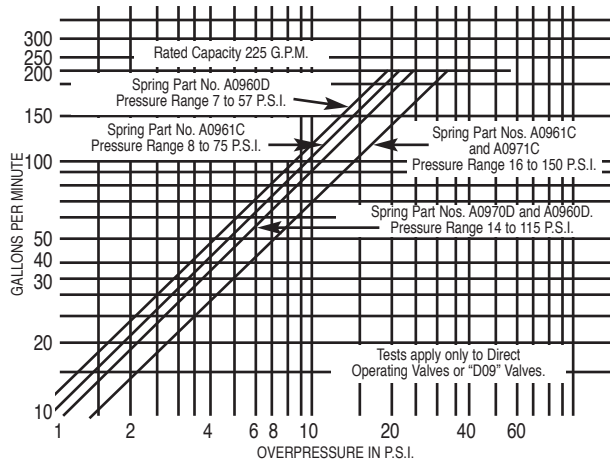

3" VALVE TESTS

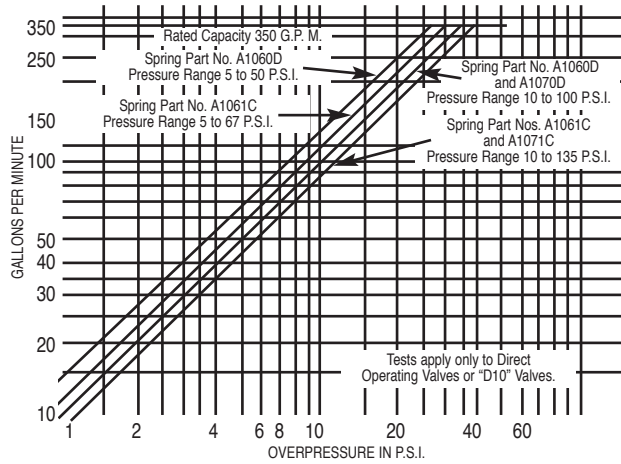

4" VALVE TESTS

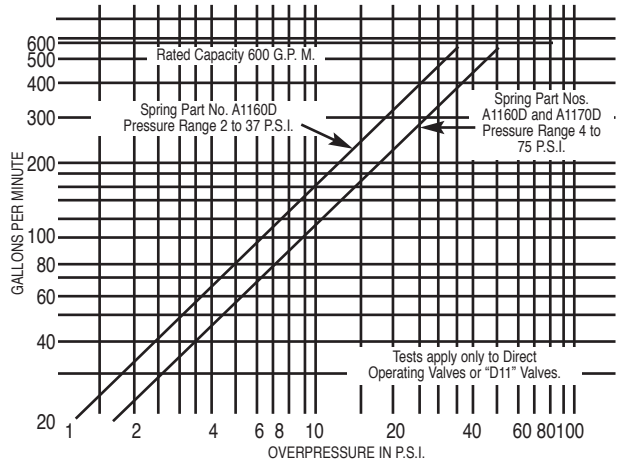

**Overpressure** - The pressure increase or accumulation above the set pressure when the valve is discharging flow.

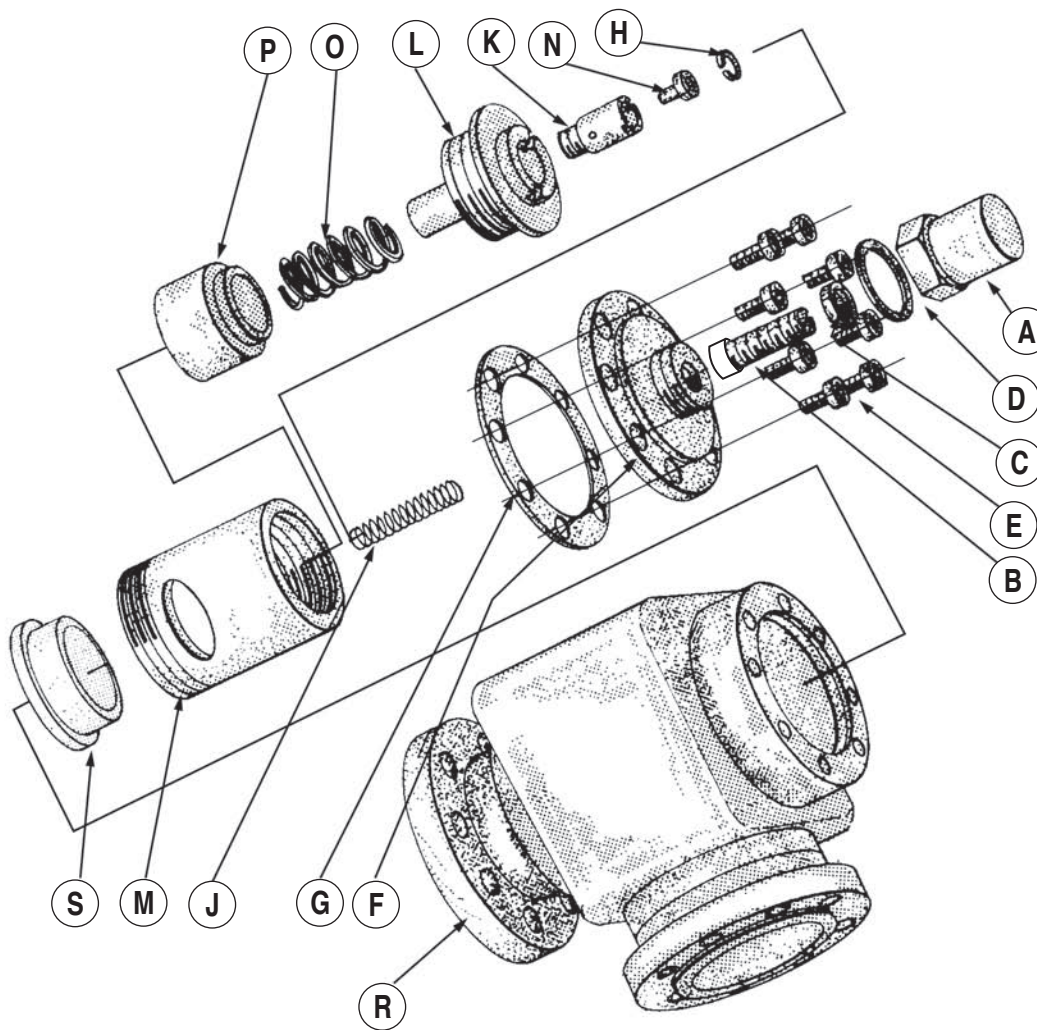

### DISASSEMBLY OF INTERNAL PILOT OPERATED VALVES

To dismantle the valve for inspection or cleaning:

1. Remove cap "A" and gasket "D"
2. Remove nut "C"
3. Remove adjusting screw "B"
4. Remove cap screws "E"
5. Remove bonnet "F"
6. Remove gasket "G"
7. Remove pilot spring "J"
8. Unscrew and withdraw cylinder "M" (do not unscrew cylinder retainer "L")
9. Unscrew and remove cylinder retainer "L", after removing cylinder "M".
10. Unscrew and remove piston retainer "K"
11. Remove retaining ring "H"
12. Remove pilot piston "N"
13. Remove balance spring "O"
14. Remove piston "P"
15. Remove retaining bushing "S" if necessary

Inspect bores of both piston retainer "K" and cylinder "M". Inspect pistons "N" and "P" for wear or scoring. Replace broken or damaged parts. Clean all parts thoroughly and re-assemble as follows:

Reverse process of disassembly from operation 16 to 6, then thread adjusting screw "B" into bonnet "F", while re-assembling "F" to body "R". Then proceed with steps 5, 4, 2, 1 in reverse order.



# A-SERIES 2½" and 3" (Internal Pilot Operated)

## DIMENSIONS

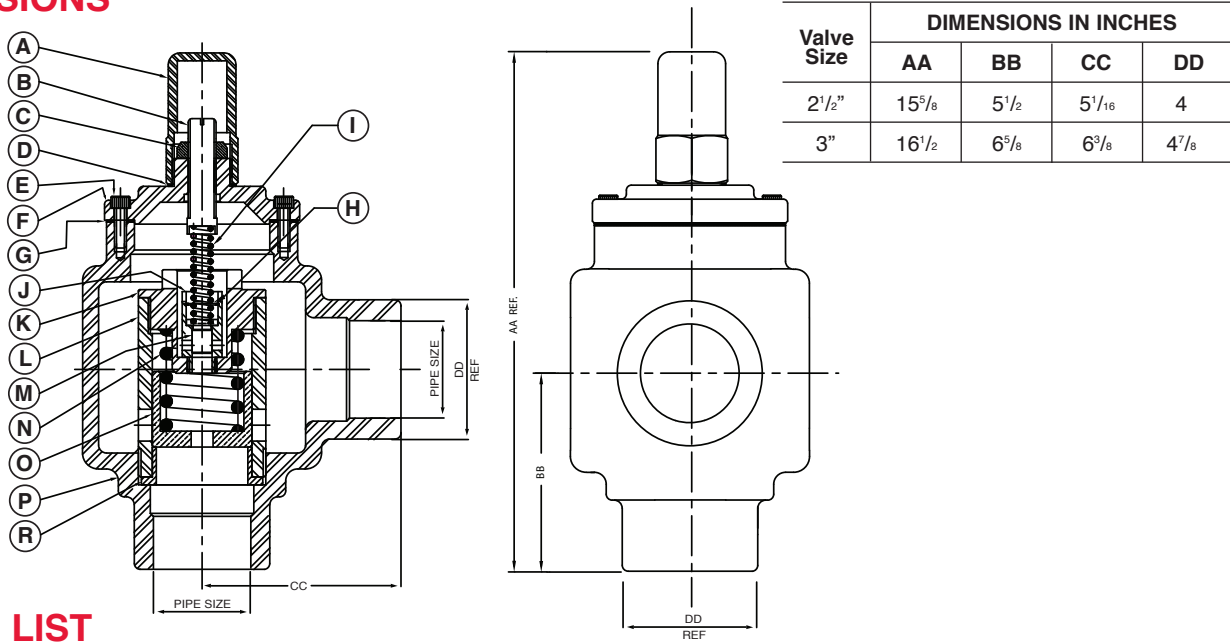

## PARTS LIST

Symbol	NAME	VALVE SIZE		
		MODEL	2½"	3"
A	Cap	AA, AC ASS	A1101CR A1101SSR	A1101CR A1101SSR
B	Adjusting Screw	AA, AC ASS	A1102C A1102SS	A1102C A1102SS
C	Lock Nut	AA, AC ASS	505-S 505-SS	505-S 505-SS
D	O-Ring †	AA, AC, ASS	604-*	604-*
E	Cap Screw	AA, AC, ASS	3/8 x 1 SHCS	3/8 x 1 SHCS
F	Bonnet Cast Iron Steel Stainless Steel	AA AC ASS	A0919A A0919C A0919SS	A1019A A1019C A1019SS
G	Gasket †	AA, AC ASS	A0903E A0903RT	A1003E A1003RT
H	Retainer Ring †	AA, AC ASS	A1120D A1120SS	A1120D A1120SS
I	Pilot Spring †	AA, AC, ASS	A1190D	A1190D
J	Piston Retainer †	AA, AC ASS	A1118C A1118SS	A1118C A1118SS
K	Cylinder Retainer	AA, AC ASS	A0912C A0912SS	A1012C A1012SS
L	Cylinder †	AA, AC ASS	A0928C A0928SS	A1028C A1028SS
M	Pilot Piston † Hardened Steel 416 Stainless-Steel 303 Stainless-Steel	AA, AC AA, AC ASS (Only)	A1115C A1115D A1115SS	A1115C A1115D A1115SS
N	Balance Spring †	AA, AC, ASS	A0980D	A1080D
O	Piston † Hardened Steel 416 Stainless-Steel 303 Stainless-Steel	AA, AC AA, AC ASS (Only)	A0936C A0936D A0936SS	A1036C A1036D A1036SS
P	Body	AA AC ASS	A0900A A0900C A0900SS	A1000A A1000C A1000SS
R	Retaining Bushing	AA, AC ASS	A0911C A0911SS	A1011C A1011SS

\* See o-ring selection chart † Recommended spare parts

# A-SERIES 2½", 3" and 4" (Internal Pilot Operated)

## DIMENSIONS

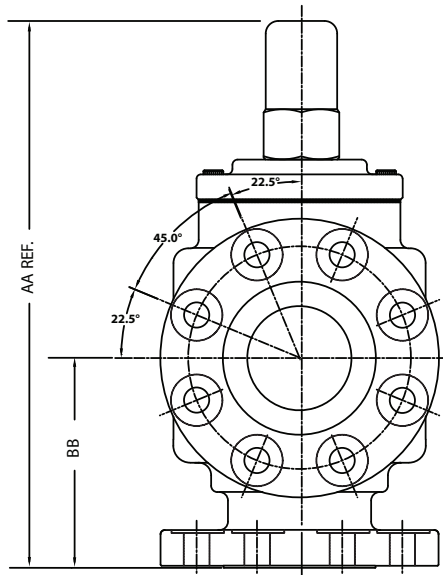
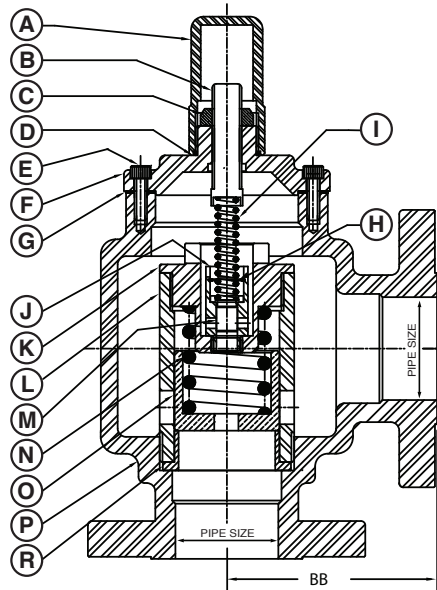

## DIMENSIONS IN INCHES

Valve Size	Flange Rating	AA	BB
2½	150# 300#	15 <sup>7</sup> / <sub>8</sub>	5 <sup>3</sup> / <sub>4</sub>
2½	600#	16 <sup>1</sup> / <sub>4</sub>	6 <sup>1</sup> / <sub>8</sub>
3	150# 300#	16 <sup>1</sup> / <sub>8</sub>	6 <sup>1</sup> / <sub>4</sub>
3	600#	16 <sup>1</sup> / <sub>2</sub>	6 <sup>5</sup> / <sub>8</sub>
4	150# 300#	18 <sup>3</sup> / <sub>16</sub>	7 <sup>15</sup> / <sub>16</sub>
4	600#	18 <sup>3</sup> / <sub>8</sub>	8 <sup>1</sup> / <sub>8</sub>

## PARTS LIST

Symbol	NAME	VALVE SIZE			
		MODEL	2½"	3"	4"
A	Cap	AA, AC ASS	A1101CR A1101SSR	A1101CR A1101SSR	A1101CR A1101SSR
B	Adjusting Screw	AA, AC ASS	A1102C A1102SS	A1102C A1102SS	A1102C A1102SS
C	Lock Nut	AA, AC ASS	505-S 505-SS	505-S 505-SS	505-S 505-SS
D	O-Ring †	AA, AC, ASS	604-*	604-*	604-*
E	Cap Screw		3/8 x 1 SHCS	3/8 x 1 SHCS	3/8 x 1 SHCS
F	Bonnet Cast Iron Steel Stainless Steel	AA AC ASS	A0919A A0919C A0919SS	A1019A A1019C A1019SS	A1119A A1119C A1119SS
G	Gasket †	AA, AC ASS	A0903E A0903RT	A1003E A1003RT	A1103E A1103RT
H	Retainer Ring †	AA, AC ASS	A1120D A1120SS	A1120D A1120SS	A1120D A1120SS
I	Pilot Spring †	AA, AC, ASS	A1190D	A1190D	A1190D
J	Piston Retainer †	AA, AC ASS	A1118C A1118SS	A1118C A1118SS	A1118C A1118SS
K	Cylinder Retainer	AA, AC ASS	A0912C A0912SS	A1012C A1012SS	A1112C A1112SS
L	Cylinder †	AA, AC ASS	A0928C A0928SS	A1028C A1028SS	A1128C A1128SS
M	Pilot Piston † Hardened Steel 416 Stainless-Steel 303 Stainless-Steel	AA, AC AA, AC ASS (Only)	A1115C A1115D A1115SS	A1115C A1115D A1115SS	A1115C A1115D A1115SS
N	Balance Spring †	AA, AC, ASS	A0980D	A1080D	A1080D
O	Piston † Hardened Steel 416 Stainless-Steel 303 Stainless-Steel	AA, AC AA, AC ASS (Only)	A0936C A0936D A0936SS	A1036C A1036D A1036SS	A1136C A1136D A1136SS
P	Body	AA AC ASS	A0900AF A0900CF A0900SSF	A1000AF A1000CF A1000SSF	A1100AF A1100CF A1100SSF
R	Retaining Bushing	AA, AC ASS	A0911C A0911SS	A1011C A1011SS	A1111C A1111SS

\* See o-ring selection chart † Recommended spare parts

# A-SERIES PERFORMANCE CHARTS

## (Internal Pilot Operated)

All valve tests 110°F. to 120°F. Oil Viscosity 150 S.S.U. at 100°F.  
(Charts good from 30 to 500 S.S.U.)

2 1/2" VALVE TESTS

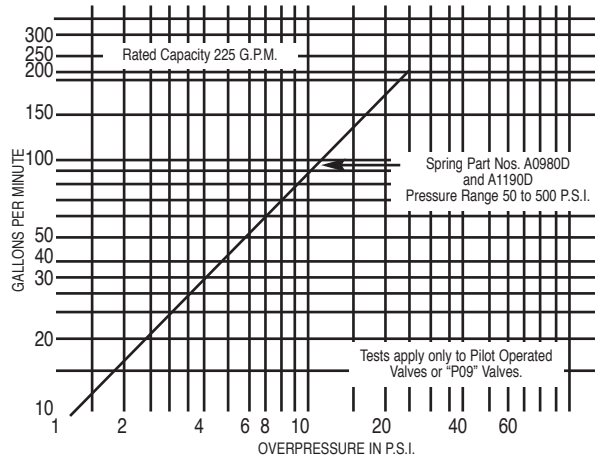

3" VALVE TESTS

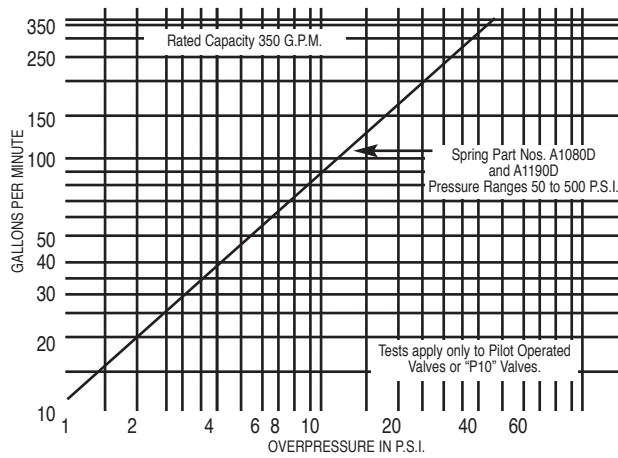

4" VALVE TESTS

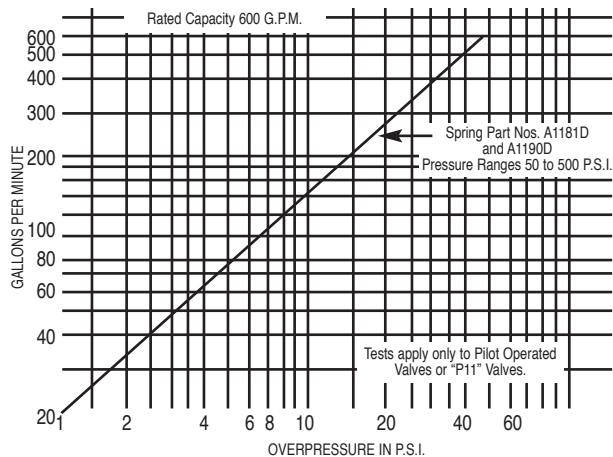

**Overpressure** - The pressure increase or accumulation above the set pressure when the valve is discharging flow.

# SVB-SERIES VALVES (UL 842 Approved)



\*Underwriter Listed  
\*ANSI, UL-842 Approved  
"Valves for Flammable Fluids"

## APPLICATION

The Fulflo SVB - Series, Underwriter Listed, range in size from 3/8" through 2" and operate efficiently with liquids of any viscosity at pressures from 3 through 500 P.S.I. The "SVB" valves are of brass construction with threaded connections.

Primarily designed for use with fuel oils on oil burner service, the "SVB" valves may be used wherever Underwriter Listed valves are required. Each valve is pre-set to the specified pressure and is equipped with a limiting device to prevent over-adjustment.

## INSTALLATION

Fulflo valves can be mounted in any position. A tee may be inserted in the pump discharge line to mount the valve. The correct size of valve should be installed, preferably matching the pump discharge line. Screw the valve into the nipple in the tee. When the valve is used for frequent bypassing of oil under pressure, its outlet should be piped back to the tank. Care

must be taken to have the discharge well below the oil level in the tank to prevent air entrainment and erratic operations.

Only if the valve is used as safety or overload relief and operates infrequently may its discharge be piped back into the pump suction line. Frequent or continuous operation under these conditions will cause excessive heating of the oil and possible damage.

# SVB-SERIES

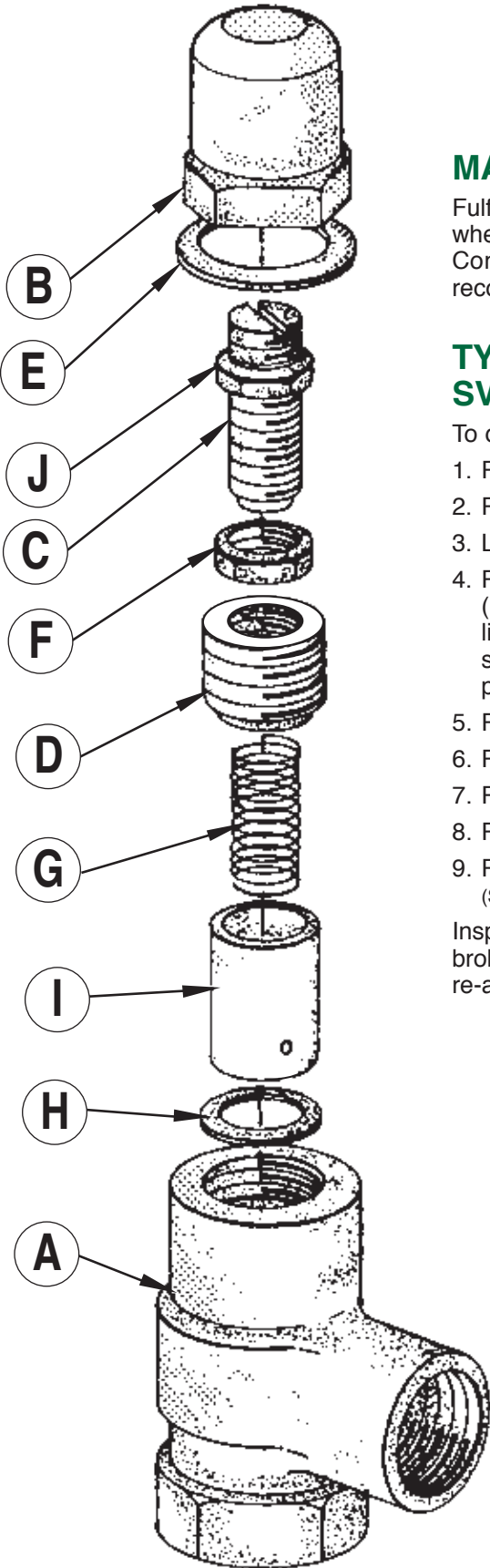

## MAINTENANCE

Fulflo valves provided reliable “chatter-free” operation when the system is free of abrasives and foreign matter. Continuous filtration of the liquid used is strongly recommended.

## TYPICAL DISASSEMBLY OF SVB VALVES

To dismantle valve for inspection and cleaning:

1. Remove cap “B”
2. Remove gasket “E” (replace, if necessary)
3. Loosen lock nut “F”
4. Remove adjusting screw “C”  
(Limit collar “J” is soldered to adjusting screw “C”, to limit the maximum pressure to which the valve may be subjected.) Limit collar is set at 25% above normal pressure setting.
5. Remove lock nut “F”
6. Remove retainer “D”
7. Remove spring “G”
8. Remove piston “I”
9. Remove stop ring “H” (Not Recommended)  
(Special tooling is required to install new stop ring.)

Inspect valve bore and piston for wear or scoring. Replace broken or damaged parts. Clean all parts thoroughly and re-assemble by reversing the above procedure.

# SVB-SERIES

## ASSEMBLY NUMBER IDENTIFICATION CHART

Symbol Number	Designation	Code	Description
1	Style	S	Underwriter Listed
2	Series	V	–
3	Material	B	Brass
4 or 5	Size	-25 -35 -45 -55 -65 -75 -85	3/8" 1/2" 3/4" 1" 1 1/4" 1 1/2" 2
6	Spring	See Chart	See Spring Pressure Chart
7	Piston	0 1 2 3	Hardened Steel, deep groove Stainless Steel, deep groove Hardened Steel, shallow groove Stainless Steel, shallow groove

### EXAMPLE:

<b>SVB-55ZSO</b>					
S	V	B	-55	ZS	O
Underwriter's Listed	Series	Brass	1"	Spring	Hardened Steel Piston, Deep Groove

### HOW TO ORDER

Specify:

1. Valve Model Number
2. Spring Letter
3. Piston Number
4. Pressure Setting

NOTE: A definite pressure setting is required due to Underwriter restrictions. A limiting device is furnished to prevent over-adjustment more than 25% above set pressure.

### SETTING VALVES

Valve may be set with a hand pump for cracking pressure. It will be noted that the maximum set pressure is limited by the collar "J" soldered to the adjusting screw "C".

If a test stand is available, valve should be connected to the discharge header with the pump bypass open, and the bypass gradually closed until the desired pressure registers on the gauge. Adjust valve adjusting screw until valve slightly bleeds at the set bypass pressure and lock adjusting screw.

If valve is required to bypass a given amount of fluid at a given pressure, a test stand having a flow meter in the pump discharge line must be available. With valve adjusted for cracking pressure as above, continue closing bypass until the required flow registers on the flow meter and observe pressure. Re-adjust pressure, if necessary, to obtain desired pressure at desired flow.

## UNDERWRITER VALVE PRESSURE RANGE CHART

Pipe Size	"U.L." Symbol	SPRING PRESSURE RANGE AND PART NO. SUFFIX											
		BLACK -AS		RED-US		GREEN-WS		YELLOW-XS		WHITE-YS		BLUE-ZS	
		Low	High	Low	High	Low	High	Low	High	Low	High	Low	High
3/8"	SVB-25	3	10	7	35	30	100	60	175	150	350	300	500
1/2"	SVB-35	3	10	7	35	30	100	60	175	150	350	300	500
3/4"	SVB-45	3	10	7	35	30	100	60	175	150	350	300	500
1"	SVB-55	3	10	7	35	30	100	60	175	150	350	300	500
1 1/4"	SVB-65	3	10	7	35	30	100	60	175	150	350	300	500
1 1/2"	SVB-75	3	10	7	35	30	100	60	175	150	350	300	500
2	SVB-85	3	10	7	35	30	100	60	175	150	350	250	600



# SVB-SERIES (Brass)

## DIMENSIONS

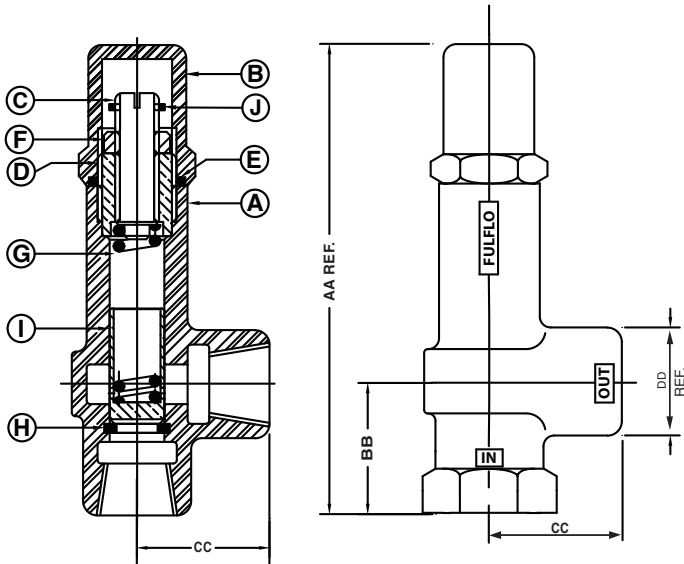

Pipe Size	"U.L." Symbol	DIMENSIONS IN INCHES			
		AA	BB	CC	DD REF.
3/8"	SVB-25	5 <sup>11</sup> / <sub>32</sub>	1 <sup>3</sup> / <sub>8</sub>	1 <sup>3</sup> / <sub>8</sub>	1 <sup>3</sup> / <sub>8</sub>
1/2"	SVB-35	6 <sup>3</sup> / <sub>16</sub>	1 <sup>11</sup> / <sub>16</sub>	1 <sup>7</sup> / <sub>16</sub>	1 <sup>7</sup> / <sub>16</sub>
3/4"	SVB-45	6 <sup>15</sup> / <sub>16</sub>	1 <sup>15</sup> / <sub>16</sub>	1 <sup>13</sup> / <sub>16</sub>	1 <sup>11</sup> / <sub>16</sub>
1"	SVB-55	8 <sup>7</sup> / <sub>32</sub>	2 <sup>9</sup> / <sub>32</sub>	2 <sup>9</sup> / <sub>32</sub>	2 <sup>7</sup> / <sub>16</sub>
1 1/4"	SVB-65	9 <sup>9</sup> / <sub>16</sub>	2 <sup>9</sup> / <sub>16</sub>	2 <sup>9</sup> / <sub>16</sub>	2 <sup>1</sup> / <sub>2</sub>
1 1/2"	SVB-75	11 <sup>1</sup> / <sub>16</sub>	2 <sup>11</sup> / <sub>16</sub>	2 <sup>11</sup> / <sub>16</sub>	2 <sup>7</sup> / <sub>8</sub>
2"	SVB-85	13	3	3	3 <sup>1</sup> / <sub>4</sub>

## PARTS LIST

Symbol	NAME	VALVE SIZE						
		3/8"	1/2"	3/4"	1"	1 1/4"	1 1/2"	2"
A	Body	200-B	300-B	400-B	500-B	600-B	700-B	800-B
B	Cap	201-B	301-B	401-B	501-B	601-B	701-B	801-B
C	Adjusting Screw	202-B	302-B	402-B	502-B	602-B	702-B	802-B
D	Retainer	203-B	303-B	403-B	503-B	603-B	703-B	803-B
E	Gasket	204	304	404	504	604	704	804
F	Lock Nut	205-S	305-S	405-S	505-S	605-S	705-S	805-S
G	Spring	See Chart	See Chart	See Chart	See Chart	See Chart	See Chart	See Chart
H	Stop Ring	208-B	308-B	408-B	508-B	608-B	708-B	808-B
I	Piston H.S. Deep Groove S.S. Deep Groove H.S. Shallow Groove S.S. Shallow Groove	206-G 206-AG 206 206-A	306-G 306-AG 306 306-A	406-G 406-AG 406 406-A	506-G 506-AG 506 506-A	606-G 606-AG 606 606-A	706-G 706-AG 706 706-A	806-G 806-AG 806 806-A
J	Limit Collar	221-B	321-B	421-B	521-B	621-B	721-B	821-B

# SVB-SERIES PERFORMANCE CHARTS

All valve tests 110°F. to 120°F. Oil Viscosity 150 S.S.U. at 100°F.  
(Charts good from 30 to 500 S.S.U.)

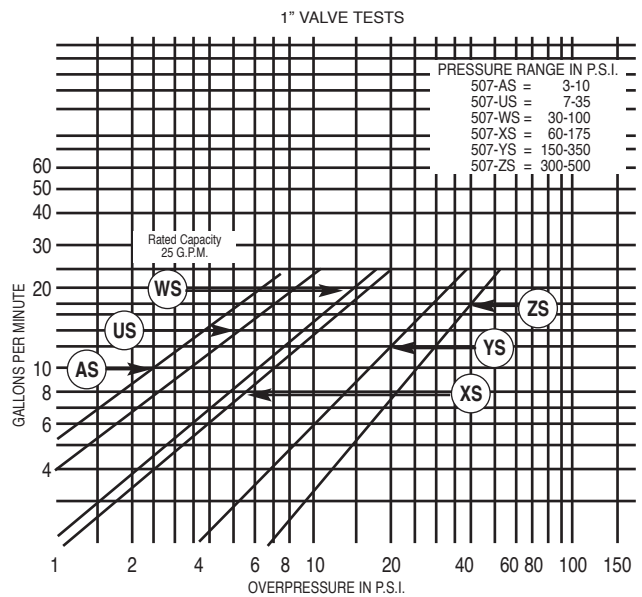
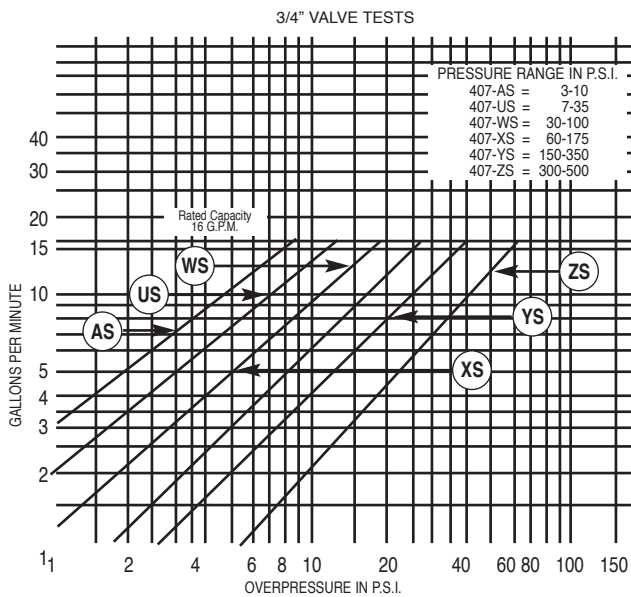
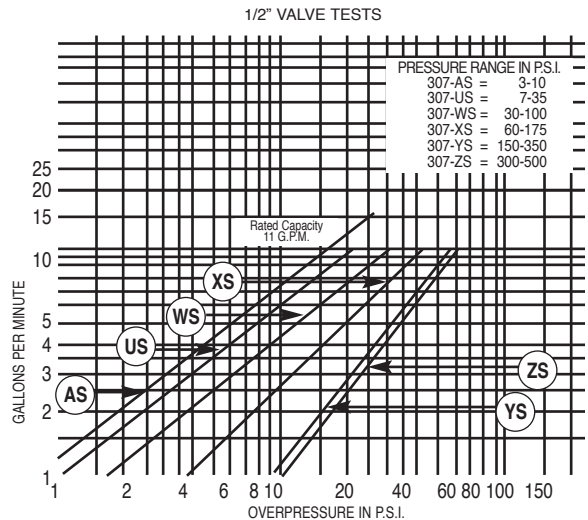
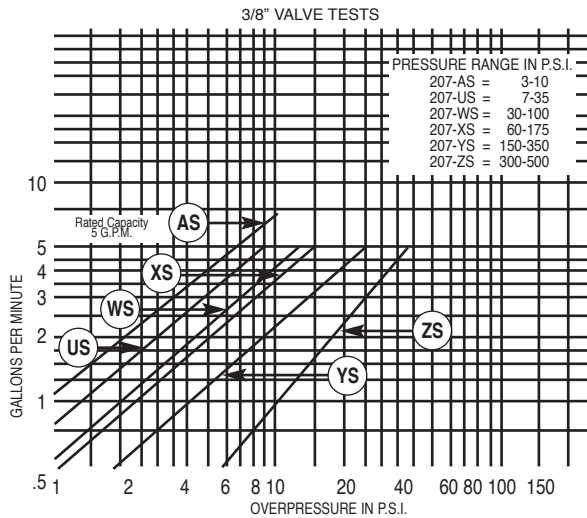

**Overpressure** - The pressure increase or accumulation above the set pressure when the valve is discharging flow.

# SVB-SERIES PERFORMANCE CHARTS

All valve tests 110°F. to 120°F. Oil Viscosity 150 S.S.U. at 100°F.  
(Charts good from 30 to 500 S.S.U.)

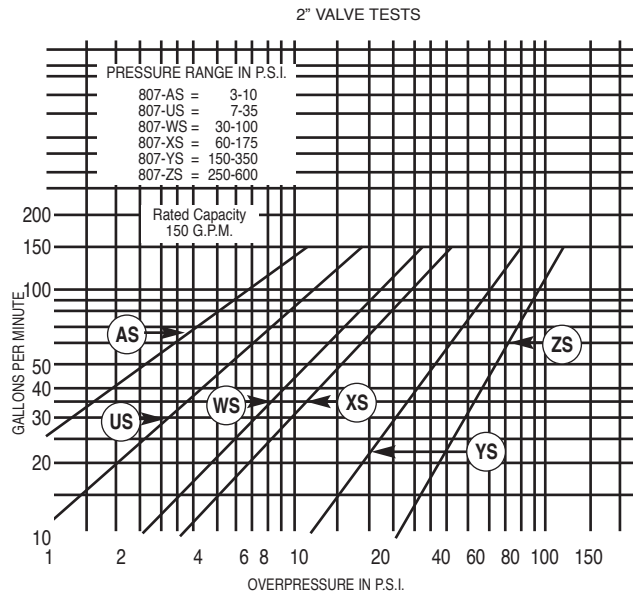
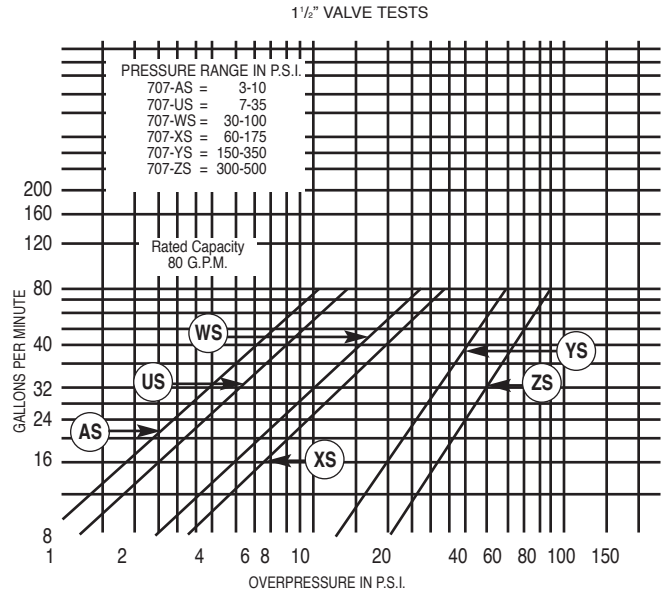
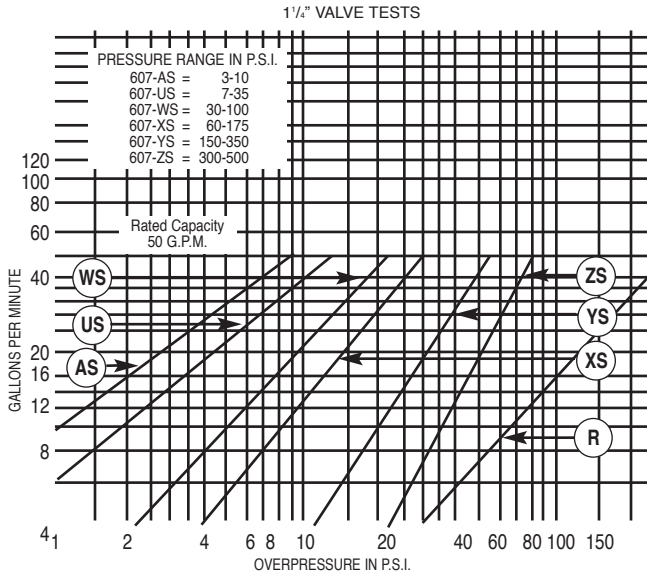

**Overpressure** - The pressure increase or accumulation above the set pressure when the valve is discharging flow.



# TYPICAL APPLICATIONS

## Combustion Equipment

Circulating Oil Systems  
Heating Equipment on Railroad Cars  
Package and Industrial Boilers  
Oil Burning Equipment

## Machine Tools

Valves are used for:  
Regulation of Lubricating System Pressure  
Regulation of Pressure for Hydraulic Feeds  
Regulation of Coolant Pressure  
Boring Machines  
Drills (Radial, Single or Multiple Spindle)  
Grinders (Surface, Cylindrical, Centerless and Universal)  
Lathes (Engine, Turret, Automatic)  
Milling Machines  
Hydraulic Tracing Units

## Hydraulic Manufacturing and Processing Equipment

Stamping Presses  
Press Brakes  
Molding Presses  
Rams  
Crushers  
Bending and Forming Equipment

## Hydraulic Test Stands

To Maintain Specific Pressures  
As Safety Relief Valve to Protect Pumps, Gauges, etc.  
Aircraft Test Equipment and Ground Support Equipment  
Equipment Test Racks  
Pressure Test Racks

## Hydraulic Power Units

Used in Basic Tank, Pump and Motor Systems

## Material Handling Equipment

Hydraulic Hoists  
Hydraulic Elevators  
Hydraulic Platforms

## Special Equipment

Fire Equipment

Laundry Equipment  
Coal Mining Equipment  
Road Spraying Machinery  
Car Washing Machinery  
Cleaning Machinery (Steam or Solution)  
Industrial Sewing Machines  
Dairy Machinery  
Special and Custom Engineered Industrial Machinery  
Equipment for Oxygen and Industrial Gases

## Industrial Air Conditioning Equipment

Pumps - Filters

## Engines and Turbines, Lubrication and Control System

Diesel Engines  
Steam Turbines  
Hydraulic Turbines  
Gas Turbines

## Mobile Equipment

## Industrial Compressors

## Processing Systems

Public Utilities  
Maintaining City Water System Pressures  
Protection and Control of Fire Hydrant Pressures  
Oil Refineries  
Chemical Plants  
Distilleries  
Irrigation Systems  
Steel Mill and Processing Plants  
Food Processing Plants  
Papermill and Pulp Processing Plants

## Liquids Handled

Hydraulic Oils  
Water (Treated, Purified and Salt Water)  
Dry Cleaning Solvent  
Heated Tar (Pumped)  
Heated Molasses (Pumped)  
Anhydrous Ammonia  
Edible Fats and Oils  
Processed Liquid Foods  
Processed Petroleum Products

APPLICATIONS

# VALVE DEFINITIONS

## Pressure Safety Valve (PSV)

A pressure safety valve actuated by inlet static pressure and characterized by rapid opening or rapid popping action. This safety valve is tight shut-off and is for safety only. Meets ASME SEC. VIII (Not a Fulflo valve)

## Pressure Relief Valve (PRV)

A pressure relief device designed to re-close and prevent further flow after normal conditions have been restored. (Fulflo)

## Relief Valve (RV)

A spring loaded pressure relief valve, actuated by the static pressure upstream of the valve. The valve opens normally in proportion to the increase in pressure over the set pressure. (Fulflo)

## Safety Relief Valve (SRV)

A pressure relief valve characterized by rapid opening or popping action in direct proportion to the pressure increase, depending on the application. (Fulflo)

## Conventional Safety Relief Valve (CSRV)

A spring-loaded pressure relief valve whose performance characteristics are directly affected by change in the back pressure of the valve. (Fulflo)

## Backpressure

The pressure existing at the outlet of a pressure relief valve, due to the pressure in the discharge system. The pressure can be constant or variable. It is the sum of the superimposed and build-up pressure.

## Cracking Pressure

The pressure which the valve starts to leak flow through the valve, but before the set pressure.

## Set Pressure

The inlet pressure the valve is adjusted to open, maintain or control under service conditions.

## Full Open Pressure

The set pressure plus overpressure is when the valve is full open

## Differential Set Pressure

The pressure differential between the set pressure and constant superimposed backpressure.

## Superimposed Backpressure

The static pressure existing at the outlet of the relief device at the time the device is required to operate. It is a result of pressure in the discharge system coming from another source. This pressure may be constant or variable.

## Overpressure

The pressure increase or accumulation above the set pressure when the valve is discharging flow.

DEFINITIONS



232  
HAND WHEEL  
NO. 1222  
STOP WASHER  
NO. 1221  
WING NUT  
NO. 1215  
BONNET NO. 1220  
ADJUSTING SCREW  
NO. 1202  
THE FULFLO  
BODY  
STOP RING  
NO. 408  
BLANCHETTER  
INC  
CORPORATION  
CORPORATION

# Fulflo

## THE FULFLO SPECIALTIES COMPANY

459 Fancy Street, Blanchester, OH 45107  
Telephone: (937) 783-2411 Fax: (937) 783-4983  
[www.fulflo.com](http://www.fulflo.com) e-mail: [info@fulflo.com](mailto:info@fulflo.com)



*“The Quiet Ones”*

CHATTER FREE PERFORMANCE

Catalog FS-10-14