

safety pressure gauges "solid-front"
DN 100 (DS 4"): all AISI 316L stainless
steel construction
DN 150 (DS 6"): all stainless steel
construction



PED 2014/68/UE ATEX 2014/34/UE TP TC 012/2011

These instruments comply with the construction and safety specifications of **EN 837-1/S3** and **ASME B40.1** standards. In case of leaks or failure of the elastic element, the operator is protected by a solid, separating wall placed on the front of the instrument and by the blow-out back. They are usually used in food, process, pharmaceutical, petrochemical industries and in conventional and nuclear power plants. The TIG welding between the case and the bulb makes the whole construction more robust and prevents leakage in case the instrument is filled with a dampening fluid protecting the instrument from vibrations. The dampening liquid filling reduces the pointer fluctuation and prevents the rotating parts of the movement from wearing out when pulsant vibrations and pulsations occur. Also, the dampening fluid prevents condensation and corrosive atmospheres from affecting the case and from damaging the internal components of the instrument.

1.20.1 - Standard Model

Design: EN837-1.

Safety designation: S3 as per EN 837-2.

Ranges: from 0...15 to 0...30000 *psi* (from 0...0,6 to 0...1600 bar or equivalent units).

Accuracy class: 1 as per EN 837-1

Ambient temperature:

-4...+149 °F (-20...+65 °C), IP55 housing (IEC 529);

-63...+149 °F (-53...+65 °C), vented IP65/67 housing (IEC 529).

Process fluid temperature: -40...+302 °F (-40...+150 °C).

Thermal drift: ±0,4 %/10 °C of range (starting from 68°F - 20°C).

Working pressure:

100% of FSV for static pressure;

90% of FSV for pulsating pressure.

Over pressure limit: 30% of FSV (max 12 hours).

Socket material: AISI 316L st.st.

Bourdon tube, seamless tube: AISI 316L st.st. for pressure ranges up to 20000 *psi* (0...1000 bar); Duplex st.st for range 2300 *psi* (0...1600 bar)

Case, ring and blow out disk:

DN100 in AISI 316L st.st.

DN 150 in AISI 304 st.st. (available in AISI316L st.st. upon request)

Window: safety glass.

Movement: stainless steel with internal limit stops.

Dial: aluminium, white with black markings.

Pointer: adjustable, aluminium, black.

1.20.2 - Fillable Model - Lower connection only

Ambient temperature: -4...+149 °F (-20...+65 °C), IP 65/67 housing (IEC 529).

Pointer: not adjustable, aluminium, black.

Other features: as Standard Model.

1.20.3 - Filled Model - Lower connection only

Ranges: from 0...15 to 0...30000 *psi* (from 0...1 to 0...1600 bar or equivalent units)

Damping liquid: glycerine 98%, silicon oil or fluorinated fluid.

Ambient temperature:

+32...+149 °F (0...+65 °C) glycerine filling;

-4...+149 °F (-20...+65 °C) silicon oil filling and fluorinated fluid filling;

-76...+149 °F (-60...+65 °C) low temperatures special silicon oil filling.

Process fluid temperature: max +149°F (+65 °C).

Protection degree: IP 65/67 as per IEC 529.

Pointer: not adjustable, aluminium, black.

Other features: as Standard Model.

INSTRUMENTS FOR OXYGEN - Glycerine or silicone oil should not be used with highly oxidizing agents such as oxygen, chlorine, nitric acid or hydrogen peroxide, because of danger of spontaneous chemical reaction, inflammability or explosion. The use of fluorinated fluid is recommended in these case.

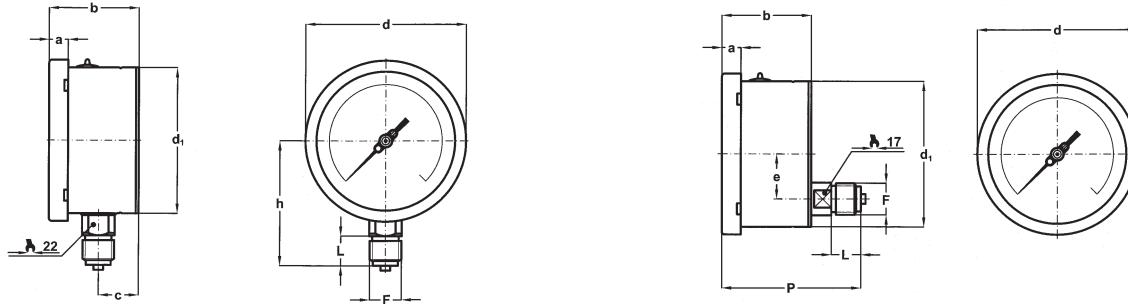

A - LOWER CONNECTION

D - BACK CONNECTION
- Standard model only

Mounting	DS	F	a	b	c	d	d ₁	e	h	p	L	Weight (1)
Lower	E 4" (100)	41M - G 1/2 A	0.51"	2.46"	1.16"	4.35"	3.97"		3.38"		0.78"	1.43 lbs
		43M - 1/2-14 NPT	(13)	(62,5)	(29,5)	(110,5)	(101)		(86)		(20)	(0,65 kg)
Lower	G 6" (150)	41M - G 1/2 A	0.59"	2.51"	1.18"	6.33"	5.92"		0.59"		0.78"	2.64 lbs
		43M - 1/2-14 NPT	(15)	(64)	(30)	(161)	(150,5)		(117)		(20)	(1,2 kg)
Back	E 4" (100)	41M - G 1/2 A	0.51"	2.46"		4.35"	3.97"	1.22"		3.75"	0.78"	1.54 lbs
		43M - 1/2-14 NPT	(13)	(62,5)		(110,5)	(101)	(31)		(95,5)	(20)	(0,70 kg)
Back	G 6" (150)	41M - G 1/2 A	0.59"	2.51"		6.33"	5.92"	1.22"		3.77"	0.78"	2.53 lbs
		43M - 1/2-14 NPT	(15)	(64)		(161)	(150,5)	(31)		(96)	(20)	(1,15 kg)

dimensions : inches (mm)

(1) add 0.95 lbs (0,43 kg) for DS 4" (100) and 1.76 lbs (0,8 kg) for DS 6" (150), when filled

OPTIONS

Model	standard	fillable	filled
C40 - Case, ring and blow out disk in AISI 316L st. st. (compulsory option for DN100)	◆	◆	◆
C - Back flange, for lower connection pressure gauges	◆	◆	◆
E - Front flange, for back connection pressure gauges	◆		
2G2 - ATEX II 2G h - Dry - A.t. -20...+60 °C (5)	◆		
2D2 - ATEX II 2GD h - Dry/Silicon oil S10 - A.t. -20...+60 °C (5)			◆ (6)
2D0 - ATEX II 2GD h - Glycerine filled - A.t. 0...+60 °C (5)			◆
2D5 - ATEX II 2GD h - Vented housing version ECV - A.t. -53...+60 °C (5)	◆ (7) (8)		
2D6 - ATEX II 2GD h - Special silicon oil S60 - A.t.-60...+60 °C (5)			◆ (9)
K06 - Accuracy class: 0,6 as per EN 837-1 (1)	◆	◆	
P02 - Oxygen service (4)	◆	◆ (2)	◆ (3)
P03 - Compensating device for DS 4" model (100 mm), lower mounting		◆	◆
S10 - Silicone oil filling			◆
E67 - Protection degree IP65/67	◆		
S60 - Special silicone oil filling for low temperatures- A.t.-60...+65 °C			◆
ECV -Vented housing version - IP65/67 -A.t.-53...+65 °C (7) (10)	◆		

- (1) For pressure ranges up to 6000 psi (400 bar).
- (2) instruments to be ordered prepared for fluorurate fluid filling (code P01)
- (3) To be ordered filled with fluorurate fluid (code F30)
- (4) For pressure ranges up to 15000 psi (1000 bar)
- (5) Please see catalogue sheet concerning the ATEX version
- (6) To be ordered with S10 option

- (7) To be ordered with E67 option
- (8) To be ordered with ECV option
- (9) To be ordered with S60 option
- (10) with corrosive atmospheres please select the filled model

"HOW TO ORDER" SEQUENCE

Section / Model /Case / Mounting / Diameter / Range / Process connection / Options

1 20 1 A E 41M C, E
2 D G 43M 2G2...ECV
3

