



OPTISONIC 4400 Technical Datasheet

Ultrasonic liquid flowmeter for high temperature and high pressure

- Accurate and repeatable measurement; long lasting and robust industrial design
- Efficient foil wave guide technology
- Dual, parallel acoustic paths



1	Product features	4
1.1	Ultrasonic liquid flowmeter for high temperature and high pressure	4
1.2	Variants	6
1.2.1	Robust solution for high temperatures	7
1.2.2	Dedicated construction for extreme pressures	7
1.3	Features	8
1.3.1	Sensor and signal converter details	8
1.3.2	Features on request	8
1.4	Measuring principle	9
2	Technical data	10
2.1	Technical data	10
2.2	Dimensions and weights	22
2.3	ASME B16.5; dimensions and weights	24
2.4	Signal converter housing	26
3	Installation	27
3.1	Intended use	27
3.2	General notes on installation	27
3.3	General requirements	28
3.3.1	Vibration	28
3.3.2	Corrosion preservation	28
3.4	Installation conditions	29
3.4.1	Inlet and outlet	29
3.4.2	Bends in 2 or 3 dimensions	29
3.4.3	T-section	30
3.5	Bends	30
3.6	Open feed or discharge	31
3.7	Position of pump	31
3.8	Control valve	31
3.9	Down going pipeline over 5 m /16 ft length	32
3.10	Thermal insulation	32
3.11	Flange deviation	34
3.12	Welding of flow sensor into the pipe	34
3.13	Mounting position	34
3.14	Mounting the field housing, remote version	35
3.14.1	Pipe mounting	35
3.14.2	Wall mounting	36
3.14.3	Turning the display of the field housing version	37
4	Electrical connections	38
4.1	Signal cable (remote versions only)	38
4.2	Power supply	38
4.3	Input and outputs, overview	40
4.3.1	Combinations of the inputs/outputs (I/Os)	40
4.3.2	Description of the CG-number	41

4.3.3 Fixed, non-alterable input/output versions.....	42
4.3.4 Alterable input/output versions.....	43
4.4 Device Configuration Form	44
5 Notes	46

1.1 Ultrasonic liquid flowmeter for high temperature and high pressure

As the successor of the UFM 530 HT/HP, with many proven-in-use installations, KROHNE again broadens your horizon with the **OPTISONIC 4400** that solves flow measurement problems by applying ultrasonic differential transit time technology.

This flow meter consists of an OPTISONIC 4000 flow sensor and an UFC 400 signal converter. The **OPTISONIC 4400** flow meter can be supplied as compact – or remote version.

A wide range of flow sensors is available to address market demands for measuring flow at harsh process conditions.

The **OPTISONIC 4400** features are:

- Safe flow measurement at elevated process temperature and pressure
- Long-lasting performance without maintenance
- Reliable flow measurement, independent of product variations

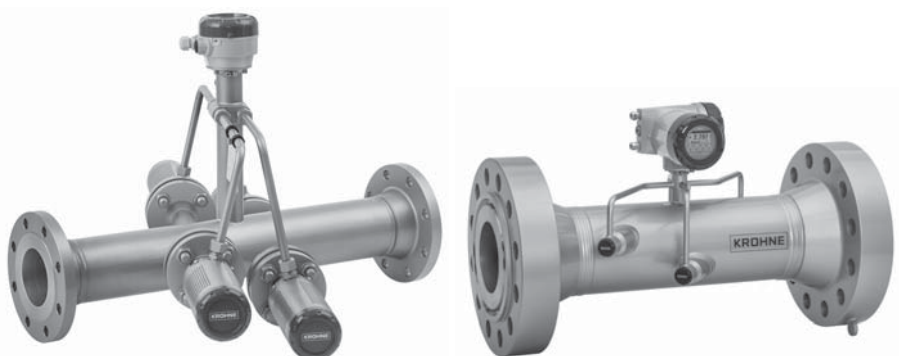

Highlights

- Advanced signal converter including enhanced diagnostics
- Full bore, unobstructed sensor tube, without pressure loss and without moving parts
- Accurate bi-directional flow measurement
- Dual parallel paths
- Chemical resistance
- Full rating designs

Industries

- Petrochemical and refinery units
 - Vacuum distillation unit
 - Visbreaking or coker unit
- Oil & Gas
 - Well injection
 - Oil transportation
 - Water/steam injection
- Energy and power plants
 - Heat transfer circuits
 - Boiler feed water
 - Solar fields
 - Solar tower receiver

Applications

- Conductive and non-conductive liquids
- Volume- and mass flow
- Multiple products and rapidly changing feed
- Heavy bottoms / main column bottoms
- Vacuum residues
- Coker feed
- Quench oil
- Synthetic thermal oil
- Molten salt

1.2 Variants

A complete range of the **OPTISONIC 4400** flow sensor designs can be configured for most of the demanding and extreme applications.

OPTISONIC 4400 HT

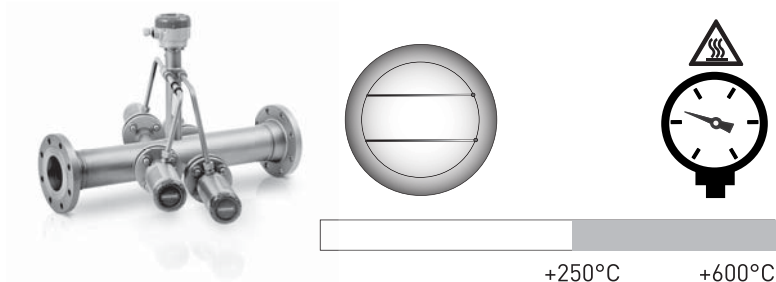

The OPTISONIC 4400 High Temperature version goes beyond the OPTISONIC 3400 measuring range and is suitable for higher pressure and very high temperatures, and constructed as a 1 or 2 path meter.

OPTISONIC 4400 HP

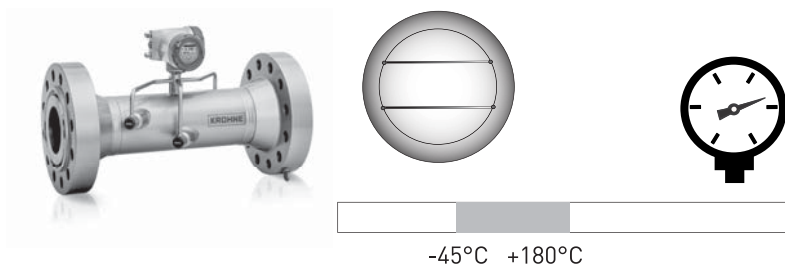

The OPTISONIC 4400 High Pressure version is dimensioned in a mid-temperature range but intended for higher pressures (up to 500 bar), and also constructed as a 1 or 2 path meter.

Comparison with the OPTISONIC 3400

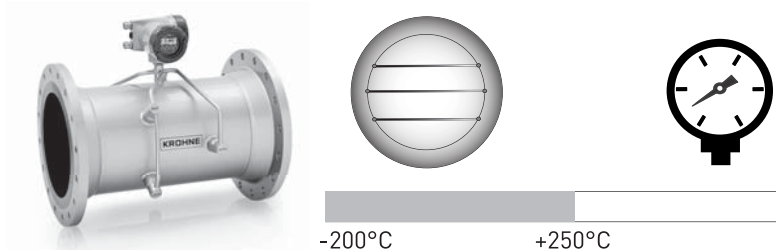

The multipurpose, all round ultrasonic flowmeter for liquids, always constructed as a 3 path meter for a wide process temperature range and up to 135 bar.

1.2.1 Robust solution for high temperatures

The OPTISONIC 4400 is a single- or dual beam ultrasonic flow meter for liquids, designed to measure high temperature liquid flow, reliable and over a long period of time without maintenance.

High Temperature version with foil wave guide technology



Application range

- Diameter range DN25...1000 / 1"...40"
- Temperature up to 600 °C / 1112 °F
- Pressure up to 100 bar (higher on request)
- Measuring tube; standard carbon steel material
- Other materials, e.g. high temperature alloys; on request

1.2.2 Dedicated construction for extreme pressures

The OPTISONIC 4400 is a single- or dual beam ultrasonic flow meter for liquids, designed for flow measurement under extreme pressure ratings.

High Pressure version



Application range

- Diameter range DN25...200 / 1"...8"
- Temperature up to 180 °C / 356 °F
- Pressure range 1500...4500 lb
- Measuring tube; standard stainless steel material
- Other materials, eg. (super) duplex; on request

1.3 Features

1.3.1 Sensor and signal converter details





Reliable flow measurement, independent of product variations

- Accurate bi-directional flow measurement
- Full bore unobstructed sensor
- No moving parts
- No pressure loss
- Active transducer parts exchangeable under pressure
- The used materials comply to requirements of the Oil and Gas Industry ie NACE MR 175/103 and ISO 15156 conformity.



UFC 400 signal converter - Compact and Remote/field

- Display with 4 optical -or push buttons
- I/O configurations available
- One universal software for all applications

-  Failure
Output signal invalid
-  Check function
Output signal (temporarily) invalid
-  Out of specification
Unreliability of output signal
-  Maintenance required
Output signal still valid

UFC 400 diagnostic capabilities:

- NE107** icons for status messages and error handling
 - visible on UFC 400 display
 - via all communication protocols
 - Status messages are grouped by problem source
 - User can change group or priority

1.3.2 Features on request

- Combinations with high temperature and/or high pressure available
- Welded-end connections
- Redundant designs, dual-, triple- and quadruple designs
- Heating jacket

1.4 Measuring principle

- Like canoes crossing a river, acoustic signals are transmitted and received along a diagonal measuring path.
- A sound wave going downstream with the flow travels faster than a sound wave going upstream against the flow.
- The difference in transit time is directly proportional to the mean flow velocity of the medium.

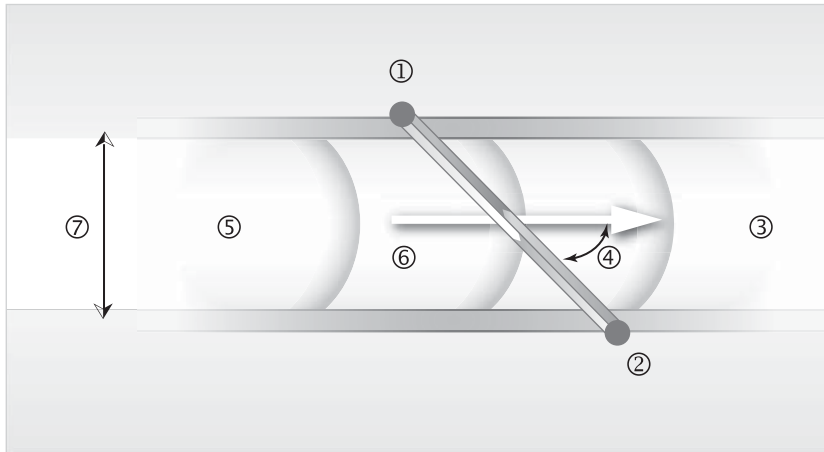

Figure 1-1: Measuring principle

- ① Transducer (wave guide) A
- ② Transducer (wave guide) B
- ③ Flow velocity
- ④ Angle of incidence
- ⑤ Velocity of sound of liquid
- ⑥ Path length
- ⑦ Inner diameter

2.1 Technical data

- *The following data is provided for general applications. If you require data that is more relevant to your specific application, please contact us or your local sales office.*
- *Additional information (certificates, special tools, software,...) and complete product documentation can be downloaded free of charge from the website (Downloadcenter).*

Measuring system

Measuring principle	Ultrasonic transit time
Application range	Flow measurement of (non) conductive fluids
Measured value	
Primary measured value	Transit time
Secondary measured values	Volume flow, mass flow, flow speed, flow direction, velocity of sound, gain, signal to noise ratio, reliability of flow measurement, totalised volume or mass

Design

Features	High Pressure : 1 or 2 parallel acoustic path(s), fully welded
	High Temperature : 1 or 2 parallel acoustic path(s)
Modular construction	The measurement system consists of a measuring sensor and a signal converter.
Compact version	OPTISONIC 4400 High Pressure
Remote version	OPTISONIC 4000 F High Pressure with UFC 400 signal converter
	OPTISONIC 4000 F High Temperature with UFC 400 signal converter
Nominal diameter	1 path: DN25...65 / 1...2,5"
	2 paths: DN80...1000 / 3...40" - (DN80 / 3"; 150, 300 lb)
Measurement range	0.5...20 m/s / 1.65...66 ft/s, bi-directional
Signal converter	
Inputs / outputs	Current (incl. HART®), pulse, frequency and/or status output, limit switch and/or control input (depending on the I/O version)
Counters	2 (optional 3) internal counters with a max. of 8 digits (e.g. for counting volume and/or mass units)
Self-diagnostics	Integrated verification, diagnostic functions: flowmeter, process, measured values, bargraph, device configuration, etc.
Communication interfaces	HART® 7, Foundation Fieldbus ITR6, Profibus PA /DP, Profile 3.02, Modbus RS485

Display and user interface	
Graphic display	LC display, backlit white
	Size: 128x64 pixels, corresponds to 59x31 mm = 2.32"x1.22"
	Display turnable in 90° steps.
Operating elements	4 optical and push buttons for operator control of the signal converter without opening the housing.
	Option: Infrared interface (GDC)
Remote operation	PACTware™ including Device Type Manager (DTM)
	HART® handheld communicator (Emerson), AMS (Emerson), PDM (Siemens)
	All DTM's and drivers will be available at the internet homepage of the manufacturer.
Display functions	
Operating menu	Programming of parameters at 2 measured value pages, 1 status page, 1 graphic page (measured values and descriptions adjustable as required)
Language of display texts	English, French, German, Dutch, Russian
Measurement functions	Units: Metric, British and US units selectable as desired from lists for volume/mass flow and counting, velocity, temperature.
	Measured values: volume flow, mass flow, flow speed, velocity of sound, gain, signal to noise ratio, flow direction, diagnostics
Diagnostic functions	Standards: VDI/NAMUR NE 107
	Status messages: Output of status messages via display, current and/or status output, HART® or via other bus interface
	Sensor diagnostics: per acoustic path velocity of sound, flow speed, gain, signal to noise ratio
	Process diagnostics: empty pipe, signal integrity, cabling, flow conditions
	Signal converter diagnostics: data bus monitoring, I/O connections, electronics temperature, parameter and data integrity

Measuring accuracy

Reference conditions	
Medium	Water
Temperature	20°C / 68°F
Pressure	1 bar / 14.5 psi
Inlet section	10 DN
Maximum measuring error	
HT version	1 path: ±1% of actual measured value ±10 mm/s
	2 paths: ±0.5% of actual measured value ±5 mm/s
	DN25 HT: ±2.5% of actual measured value ±25 mm/s
HP version	±1% of actual measured value ±10 mm/s
Repeatability	1 path: ±0.6%
	2 paths: ±0.3%

Operating conditions

Temperature	
Process temperature	
High pressure version	Compact version: -45...+140°C / -49...+284°F Remote version: -45...+180°C / -49...+356°F
High temperature version	Remote version in general area: -45...+600°C / -49...+1112°F Remote version in hazardous area: -45...+440°C / -49...+824°F
For carbon steel flanges min. process temperature acc. to ASME: -29 °C / -20 °F	
Ambient temperature	Sensor; -40...+70°C / -40...+158°F
	Signal converter; -40...+65°C / -40...+149°F
	Option (stainless steel converter housing): -40...+60°C / -40...+140°F
	Ambient temperatures below -25°C / -13°F may affect the readability of the display.
Protect the signal converter from external heat sources such as direct sunlight, as higher temperatures reduce the life cycle of all electronic components.	
Storage temperature	-50...+70°C / -58...+158°F
Pressure	
ASME B16.5	
High temperature version:	DN25...300 / 1...12": 150...600 lb RF, 600 RTJ, 900 lb RTJ
	DN350...600 / 14...24": 150...600 lb RF, 600 lb RTJ
	Larger diameters and higher pressure ratings on request
High pressure version:	DN25...50 / 1...2": 1500 lb RTJ
	DN80, 200 / 3... 8": 2500 lb RTJ
	Larger diameters and higher pressure ratings on request.
EN 1092-1	On request
Design specification for pressure and temperature according to ASME	
OPTISONIC 4000 (F) :	HT at a temperature of : 250°C max 190 bar / 540°C max 160 bar / 600°C max 60 bar 482°F max 2756 psi / 1004°F max 2321 psi / 1112°F max 870 psi
OPTISONIC 4000 (C/F)	HP at a temperature of : 20°C max 490 bar / 140°C max 440 bar / 180°C max 420 bar 68°F max 7107 psi / 284°F max 6382 psi / 356°F max 6092 psi
DIN	On request
Properties of medium	
Physical condition	Liquid, single phase (well mixed, rather clean)
Permissible gas content	≤ 2% (volume)
Permissible solid content	≤ 5% (volume)
Viscosity	Maximum viscosity : on request

Installation conditions

Installation	For detailed information refer to <i>Installation</i> on page 27.
Inlet run	2 paths: 10 DN (straight inlet)
	1 path: 20 DN (straight inlet)
	If no details are known, minimal 20 DN recommended
Outlet run	Minimal 3 DN (straight outlet)
	If no details are known, minimal 5 DN recommended
Dimensions and weights	For detailed information refer to <i>Dimensions and weights</i> on page 22.

Materials

Measuring sensor	
Flanges (wetted)	HT version: DN25...1000 / 1"...40", Standard: Carbon steel ASTM A105N Option: Stainless steel AISI 316(L)
	HP version: DN25...200 / 1"...8", Stainless steel AISI 316 (L)
	Other materials on request.
Measuring Tube (wetted)	HT version: DN25...1000 / 1"...40", Standard: Carbon steel ASTM A106 gr B Option: Stainless steel AISI 316(L)
	HP version: DN25...200 / 1"...8": Stainless steel AISI 316 (L)
	Other materials on request.
Sensor conduits	Stainless steel 1.4404 (AISI 316L)
Sensor neck	Stainless steel AISI 316 (1.4408)
Transducers (wetted) HT version:	Stainless steel (321(H))
	Other materials on request.
HP version:	Stainless steel 1.4404 (AISI 316L)
Transducer holders	HP only: stainless steel 1.4404 (AISI 316L) (same material as flanges)
Transducer nozzles	Stainless steel (AISI 316L)
Transducer counter flanges	HT only: Stainless steel 1.4404 (AISI 316L)
Transducer gaskets,	HT only: Spiral wound graphite / SS for hydrocarbons up to 450°C.
	For higher temperatures: depending on application, consult Krohne.
Connection box (remote version only)	Standard: Die-cast aluminium; coated
	Option: Stainless steel 316 (1.4408)
Coating (measuring sensor)	HT version; blasted; corrosion preservative
	Option: coating on request
	HP version: coated
	Option: Offshore coating
NACE conformity	Wetted transducers conform NACE MR 175/103 and ISO 15156
	Option: measuring tube and flanges on request
Signal converter	
Housing	Versions C and F: Die-cast aluminum
	Option: Stainless steel 316 (1.4408)
Coating	Standard
	Option: Offshore coating

Electrical connections

Description of used abbreviations; Q=xxx; I_{\max} = maximum current; U_{i_n} = xxx; U_{int} = internal voltage; U_{ext} = external voltage; $U_{\text{int, max}}$ = maximal internal voltage	
General	Electrical connection is carried out in conformity with the VDE 0100 directive "Regulations for electrical power installations with line voltages up to 1000 V" or equivalent national specifications.
Power supply	Standard: 100...230 VAC (-15% / +10%), 50/60 Hz
	Option: 24 VAC/DC (AC: -15% / +10%; DC: -25% / +30%)
Power consumption	AC: 22 VA
	DC: 12 W
Signal cable (remote version only)	Shielded cable with 4 coax cores: \varnothing 10.6 mm / 0.4"
	5 m / 16 ft
	Option: 10...30 m / 33...98 ft
Cable entries	Standard: M20 x 1.5 (8...12 mm)
	Option: 1/2" NPT, PF 1/2

Inputs and outputs

General	All outputs are electrically isolated from each other and from all other circuits.
	All operating data and output values can be adjusted.
Description of used abbreviations	U_{ext} = external voltage; R_L = load + resistance; U_0 = terminal voltage; I_{nom} = nominal current Safety limit values (Ex i): U_i = max. input voltage; I_i = max. input current; P_i = max. input power rating; C_i = max. input capacity; L_i = max. input inductivity

Current output			
Output data	Measurement of volume flow, mass flow, flow speed, velocity of sound, gain, SNR, diagnostics 1, 2, NAMUR NE107, HART [®] communication.		
Temperature coefficient	Typically ± 30 ppm/K		
Settings	Without HART[®]		
	Q = 0%: 0...20 mA; Q = 100%: 10...20 mA		
	Error identification: 3...22 mA		
	With HART[®]		
	Q = 0%: 4...20 mA; Q = 100%: 10...20 mA		
	Error identification: 3...22 mA		
	Q = 100%: 10...20 mA		
Operating data	Basic I/Os	Modular I/Os	Ex i
	Active	$U_{\text{int, nom}} = 24$ VDC $I \leq 22$ mA $R_L \leq 1$ k Ω	$U_{\text{int, nom}} = 20$ VDC $I \leq 22$ mA $R_L \leq 450$ Ω $U_0 = 21$ V $I_0 = 90$ mA $P_0 = 0.5$ W $C_0 = 90$ nF / $L_0 = 2$ mH $C_0 = 110$ nF / $L_0 = 0.5$ mH
Passive	$U_{\text{ext}} \leq 32$ VDC $I \leq 22$ mA $U_0 \geq 1.8$ V $R_{L, \text{max}} = (U_{\text{ext}} - U_0) / I_{\text{max}}$	$U_{\text{ext}} \leq 32$ VDC $I \leq 22$ mA $U_0 \geq 4$ V $R_{L, \text{max}} = (U_{\text{ext}} - U_0) / I_{\text{max}}$ $U_i = 30$ V $I_i = 100$ mA $P_i = 1$ W $C_i = 10$ nF $L_i \sim 0$ mH	

HART®			
Description	HART® protocol via active and passive current output		
	HART® version: V7		
	Universal HART® parameter: completely integrated		
Load	≥ 250 Ω t HART® test point: Note maximum load for current output!		
Multidrop	Yes, current output = 4 mA		
	Multidrop addresses adjustable in operation menu 1...15		
Device drivers	DD for FC 375/475, AMS, PDM, DTM for FDT		
Pulse or frequency output			
Output data	Volume flow, mass flow		
Function	Adjustable as pulse or frequency output		
Pulse rate/frequency	0.01...10000 pulses/s or Hz		
Settings	For Q = 100%: 0.01... 10000 pulses per second or pulses per unit volume.		
	Pulse width: adjustable as automatic, symmetric or fixed (0.05...2000 ms)		
Operating data	Basic I/Os	Modular I/Os	Ex i
Active	-	$U_{nom} = 24 \text{ VDC}$ f_{max} in operating menu set to: $f_{max} \leq 100 \text{ Hz}$ $I \leq 20 \text{ mA}$ $R_{L, max} = 47 \text{ k}\Omega$ open: $I \leq 0.05 \text{ mA}$ closed: $U_{0, nom} = 24 \text{ V}$ at $I = 20 \text{ mA}$	-
		F_{max} in operating menu set to: $100 \text{ Hz} < f_{max} \leq 10 \text{ kHz}$ $I \leq 20 \text{ mA}$ $R_L \leq 10 \text{ k}\Omega$ for $f \leq 1 \text{ kHz}$ $R_L \leq 1 \text{ k}\Omega$ for $f \leq 10 \text{ kHz}$ open: $I \leq 0.05 \text{ mA}$ closed: $U_{0, nom} = 22.5 \text{ V}$ at $I = 1 \text{ mA}$ $U_{0, nom} = 21.5 \text{ V}$ at $I = 10 \text{ mA}$ $U_{0, nom} = 19 \text{ V}$ at $I = 20 \text{ mA}$	

Passive	$U_{\text{ext}} \leq 32 \text{ VDC}$		-
	f_{max} in operating menu set to: $f_{\text{max}} \leq 100 \text{ Hz}$: $I \leq 100 \text{ mA}$ $R_{L, \text{max}} = 47 \text{ k}\Omega$ $R_{L, \text{max}} = (U_{\text{ext}} - U_0) / I_{\text{max}}$ open: $I \leq 0.05 \text{ mA}$ at $U_{\text{ext}} = 32 \text{ VDC}$ closed: $U_{0, \text{max}} = 0.2 \text{ V}$ at $I \leq 10 \text{ mA}$ $U_{0, \text{max}} = 2 \text{ V}$ at $I \leq 100 \text{ mA}$		
	f_{max} in operating menu set to: $100 \text{ Hz} < f_{\text{max}} \leq 10 \text{ kHz}$: $I \leq 20 \text{ mA}$ $R_L \leq 10 \text{ k}\Omega$ for $f \leq 1 \text{ kHz}$ $R_L \leq 1 \text{ k}\Omega$ for $f \leq 10 \text{ kHz}$ $R_{L, \text{max}} = (U_{\text{ext}} - U_0) / I_{\text{max}}$ open: $I \leq 0.05 \text{ mA}$ at $U_{\text{ext}} = 32 \text{ VDC}$ closed: $U_{0, \text{max}} = 1.5 \text{ V}$ at $I \leq 1 \text{ mA}$ $U_{0, \text{max}} = 2.5 \text{ V}$ at $I \leq 10 \text{ mA}$ $U_{0, \text{max}} = 5.0 \text{ V}$ at $I \leq 20 \text{ mA}$		
NAMUR	-	Passive to EN 60947-5-6 open: $I_{\text{nom}} = 0.6 \text{ mA}$ closed: $I_{\text{nom}} = 3.8 \text{ mA}$	Passive to EN 60947-5-6 open: $I_{\text{nom}} = 0.43 \text{ mA}$ closed: $I_{\text{nom}} = 4.5 \text{ mA}$
			$U_i = 30 \text{ V}$ $I_i = 100 \text{ mA}$ $P_i = 1 \text{ W}$ $C_i = 10 \text{ nF}$ $L_i = 0 \text{ mH}$

Status output / limit switch			
Function and settings	Adjustable as automatic measuring range conversion, display of flow direction, overflow, error, switching point		
	Valve control with activated dosing function		
Operating data	Basic I/Os	Modular I/Os	Ex i
Active	-	$U_{int} = 24 \text{ VDC}$ $I \leq 20 \text{ mA}$ $R_{L, max} = 47 \text{ k}\Omega$ open: $I \leq 0.05 \text{ mA}$ closed: $U_{0, nom} = 24 \text{ V}$ at $I = 20 \text{ mA}$	-
Passive	$U_{ext} \leq 32 \text{ VDC}$ $I \leq 100 \text{ mA}$ $R_{L, max} = 47 \text{ k}\Omega$ $R_{L, max} = (U_{ext} - U_0) / I_{max}$ open: $I \leq 0.05 \text{ mA}$ at $U_{ext} = 32 \text{ VDC}$ closed: $U_{0, max} = 0.2 \text{ V}$ at $I \leq 10 \text{ mA}$ $U_{0, max} = 2 \text{ V}$ at $I \leq 100 \text{ mA}$	$U_{ext} = 32 \text{ VDC}$ $I \leq 100 \text{ mA}$ $R_{L, max} = 47 \text{ k}\Omega$ $R_{L, max} = (U_{ext} - U_0) / I_{max}$ open: $I \leq 0.05 \text{ mA}$ at $U_{ext} = 32 \text{ VDC}$ closed: $U_{0, max} = 0.2 \text{ V}$ at $I \leq 10 \text{ mA}$ $U_{0, max} = 2 \text{ V}$ at $I \leq 100 \text{ mA}$	-
NAMUR	-	Passive to EN 60947-5-6 open: $I_{nom} = 0.6 \text{ mA}$ closed: $I_{nom} = 3.8 \text{ mA}$	Passive to EN 60947-5-6 open: $I_{nom} = 0.43 \text{ mA}$ closed: $I_{nom} = 4.5 \text{ mA}$ $U_i = 30 \text{ V}$ $I_i = 100 \text{ mA}$ $P_i = 1 \text{ W}$ $C_i = 10 \text{ nF}$ $L_i = 0 \text{ mH}$

Control input			
Function	Hold value of the outputs (e.g. for cleaning work), set value of the outputs to "zero", counter and error reset, stop counter, range conversion, zero calibration		
	Start of dosing when dosing function is activated.		
Operating data	Basic I/Os	Modular I/Os	Ex i
Active	-	$U_{int} = 24 \text{ VDC}$ Terminals open: $U_{0, nom} = 22 \text{ V}$ Terminals bridged: $I_{nom} = 4 \text{ mA}$ On: $U_0 \geq 12 \text{ V}$ with $I_{nom} = 1.9 \text{ mA}$ Off: $U_0 \leq 10 \text{ V}$ with $I_{nom} = 1.9 \text{ mA}$	-
Passive	$U_{ext} \leq 32 \text{ VDC}$ $I_{max} = 6.5 \text{ mA}$ at $U_{ext} \leq 24 \text{ VDC}$ $I_{max} = 8.2 \text{ mA}$ at $U_{ext} \leq 32 \text{ VDC}$ Contact closed (On): $U_0 \geq 8 \text{ V}$ with $I_{nom} = 2.8 \text{ mA}$ Contact open (Off): $U_0 \leq 2.5 \text{ V}$ with $I_{nom} = 0.4 \text{ mA}$	$U_{ext} \leq 32 \text{ VDC}$ $I_{max} = 9.5 \text{ mA}$ at $U_{ext} \leq 24 \text{ V}$ $I_{max} = 9.5 \text{ mA}$ at $U_{ext} \leq 32 \text{ V}$ Contact closed (On): $U_0 \geq 3 \text{ V}$ with $I_{nom} = 1.9 \text{ mA}$ Contact open (Off): $U_0 \leq 2.5 \text{ V}$ with $I_{nom} = 1.9 \text{ mA}$	$U_{ext} \leq 32 \text{ VDC}$ $I \leq 6 \text{ mA}$ at $U_{ext} = 24 \text{ V}$ $I \leq 6.6 \text{ mA}$ at $U_{ext} = 32 \text{ V}$ On: $U_0 \geq 5.5 \text{ V}$ or $I \geq 4 \text{ mA}$ Off: $U_0 \leq 3.5 \text{ V}$ or $I \leq 0.5 \text{ mA}$
			$U_i = 30 \text{ V}$ $I_i = 100 \text{ mA}$ $P_i = 1 \text{ W}$ $C_i = 10 \text{ nF}$ $L_i = 0 \text{ mH}$
NAMUR	-	Active to EN 60947-5-6 Contact open: $U_{0, nom} = 8.7 \text{ V}$ Contact closed (On): $I_{nom} = 7.8 \text{ mA}$ Contact open (off): $U_{0, nom} = 6.3 \text{ V}$ with $I_{nom} = 1.9 \text{ mA}$ Identification for open terminals: $U_0 \geq 8.1 \text{ V}$ with $I \leq 0.1 \text{ mA}$ Identification for short circuited terminals: $U_0 \leq 1.2 \text{ V}$ with $I \geq 6.7 \text{ mA}$	-

PROFIBUS PA / DP	
Description	Galvanically isolated acc. to IEC 61158
	Profile version: 3.02
	Current consumption: 10.5 mA
	Permissible bus voltage: 9...32 V; in Ex application 9...24 V
	Bus interface with integrated reverse polarity protection
	Typical error current FDE (Fault Disconnection Electronic): 4.3 mA
	Bus address adjustable via local display on the measuring device
Function blocks	6 x analogue input, 3 x totaliser
Output data	Volume flow, mass flow, velocity of sound, flow speed, gain, SNR, electronic temperature, power supply (Further meas. values and diagnostic data is available via acyclic access)
FOUNDATION Fieldbus	
Description	Galvanically isolated acc. to IEC 61158
	Current consumption: 10.5 mA
	Permissible bus voltage: 9...32 V; in Ex application 9...24 V
	Bus interface with integrated reverse polarity protection
	Link Master function (LM) supported
	Tested with Interoperable Test Kit (ITK) version 6.0
Function blocks	4 x analogue input, 2 x integrator, 1 x PID
Output data	Volume flow, mass flow, flow speed, electronic temperature, velocity of sound, gain, SNR Diagnostic data
MODBUS	
Description	Modbus RTU, Master / Slave, RS485
Address range	1...247
Supported function codes	01, 02, 03, 04, 05, 08, 16, 43
Supported Baudrate	1200, 2400, 4800, 9600, 19200, 38400, 57600, 115200 Baud

Approvals and certificates

CE	
This device fulfills the statutory requirements of the EU directives. The manufacturer certifies successful testing of the product by applying the CE mark.	
	For full information of the EU directive & standards and the approved certifications; please refer to the CE declaration or the website of the manufacturer.
NAMUR	NE 21,43,53,80,95,107
Other approvals and standards	
Non-Ex	Standard
Hazardous areas	
Ex zone 1 - 2	For detailed information, please refer to the relevant Ex documentation. According to European Directive 2014/34/EU
IECEX	IECEX KIWA 15.0032X
ATEX	KIWA 15ATEX0054 X
cQPSus ; class 1 Div. 1 and 2	Approval number; LR1338
NEPSI	Approval number; pending
DNV	Approval number; pending
EAC	Approval number; pending
Protection category acc. to IEC 529 / EN 60529	Signal converter
	Compact (C): IP66/67 (NEMA 4X/6)
	Field (F): IP66/67 (NEMA 4X/6)
	All flow sensors
	IP67 (NEMA 6)
Shock resistance	IEC 68-2-27
	30 g for 18 ms
Vibration resistance	IEC 68-2-64
	f= 20 - 2000 Hz, rms=4,5g, t=30 min.

2.2 Dimensions and weights

The dimensions and weights of the different available versions are described on the following pages.

Description of the abbreviations:

- L = total length of the flowmeter
- H = height of the flowmeter (without mounted converter / connection box)
- W (W1) = width of the flanges
- W2 = total width of the flow sensor including transducers
- Di = internal width of flow sensor

Remote version High Temperature

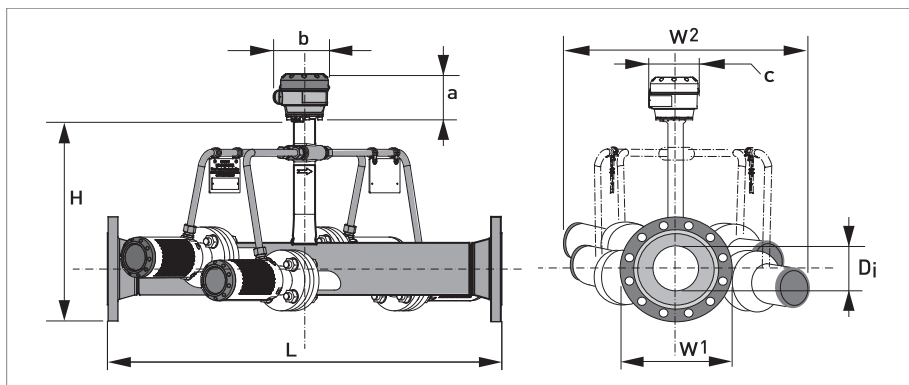

a	88 mm / 3.5"
b	139 mm / 5.5" ①
c	106 mm / 4.2"

① The value may vary depending on the used cable glands.

Note; the dimension W2 varies, depending on the construction and diameter. The average dimension is approximately 820 mm / 31.7" (± 30mm / 1.2")

Compact version High Pressure

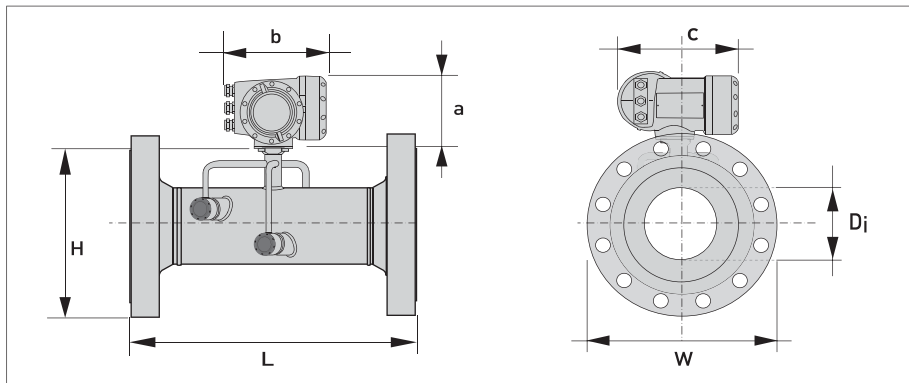

a	155 mm / 6.1"
b	230 mm / 9.1" ①
c	260 mm / 10.2"
Total height = H + a #The value depends on version	

① The value may vary depending on the used cable glands.

2.3 ASME B16.5; dimensions and weights

For additional values and dimensions (e.g. not mentioned in tables); consult KROHNE.

ASME 150 lb; High temperature variant - RF flange

Nom. size	Dimensions									
	L		H		W - W1		Inner diameter [Di]		Weight	
	[inch]	[mm]	[inch]	[mm]	[inch]	[mm]	[inch]	[mm]	[lb]	[kg]
1"										
2"	27.6	700	15.4	392	6.0	152	2.1	52.5	50	23
3"										
4"	35.4	900	18.0	457	9.0	229	4.0	102	125	57
6"	35.4	900	20.1	510	11.0	279	6.1	151	161	73
8"										
10"	39.4	1000	24.6	626	16.0	406	10.0	254	287	130
12"	39.4	1000	27.1	689	19.0	483	12.0	305	364	165
14"										
16"	39.4	1000	31.0	788	23.5	597	15.0	381	569	258
18"										
20"	39.4	1000	35.0	889	27.5	699	19.0	483	672	305
24"	39.4	1000	39.3	997	32.0	813	23.0	585	886	402

ASME 300 lb; High temperature variant - RF flange

Nom. size	Dimensions									
	L		H		W - W1		Inner diameter [Di]		Weight	
	[inch]	[mm]	[inch]	[mm]	[inch]	[mm]	[inch]	[mm]	[lb]	[kg]
1"										
2"	27.6	700	15.4	392	6.0	152	2.1	52.5	50	23
3"	35.4	900	18.0	457	9.0	229	3.1	4.0	102	51
4"	35.4	900	18.5	470	10.0	254	3.8	97.1	181	82
6"	35.4	900	20.8	529	12.5	318	5.8	146	229	104
8"	39.4	1000	23.1	586	15.0	381	7.6	194	373	169
10"	39.4	1000	25.4	645	17.5	445	9.7	248	414	188
12"	39.4	1000	27.9	708	20.5	521	11.4	289	606	275
14"	39.4	1000	29.8	756	23.0	584	12.5	317	767	348
16"	39.4	1000	33.3	845	28.0	711	14.3	364	955	433
18"										
20"	39.4	1000	36.5	927	30.5	775	18.4	467	1497	679
24"										

ASME 600 lb; High temperature variant, RF & RTJ flanges

Nom. size	Dimensions									
	L		H		W - W1		Inner diameter [Di]		Weight	
	[inch]	[mm]	[inch]	[mm]	[inch]	[mm]	[inch]	[mm]	[lb]	[kg]
1"										
2"	27.6	700	15.7	399	6.5	165	1.7	42.9	66	30
3"										
4"	35.4	900	18.9	480	10.8	273	3.6	92	194	88
6"	35.4	900	21.6	548	14.0	356	5.5	140	317	144
8"										
10"	43.3	1100	26.6	677	20.0	508	9.3	236	679	308
12"	39.4	1000	28.6	727	22.0	559	10.8	273	884	401

ASME 1500 lb; High pressure variant - RTJ flange

Nom. size	Dimensions									
	L		H		W - W1		Inner diameter [Di]		Weight	
	[inch]	[mm]	[inch]	[mm]	[inch]	[mm]	[inch]	[mm]	[lb]	[kg]
1"	13.8	350	7.1	181	5.9	149	0.8	21	32	14
2"	23.6	600	9.0	228	8.5	216	1.7	43	74	34
3"	27.6	700	10.5	268	10.5	267	2.6	67	130	59
4"	39.4	1000	11.9	303	12.3	311	3.4	87	214	97
6"										
8"	39.4	1000	13.8	351	19.0	483	6.8	173	745	338

2.4 Signal converter housing

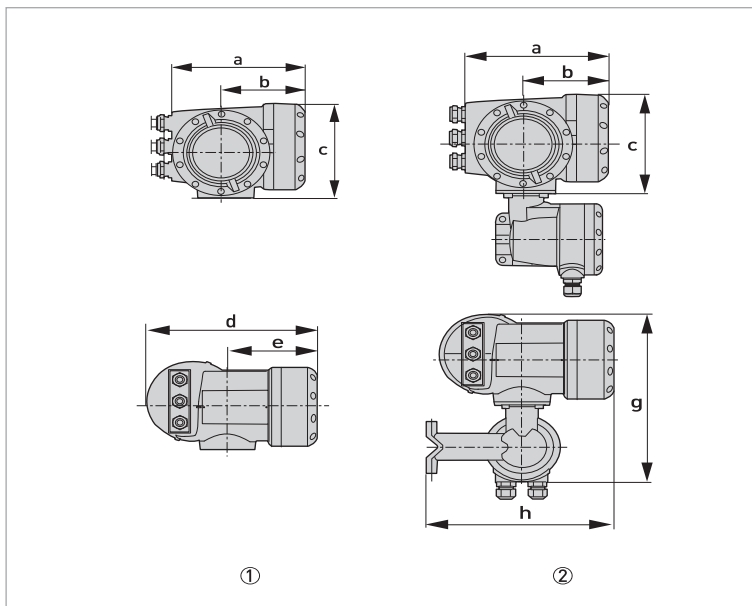

- ① Compact housing [C]
- ② Field housing [F]

Dimensions and weights in mm and kg

Version	Dimensions [mm]							Weight [kg]
	a	b	c	d	e	g	h	
C	202	120	155	260	137	-	-	4.2
F	202	120	155	-	-	295.8	277	5.7

Dimensions and weights in inch and lb

Version	Dimensions [inch]							Weight [lb]
	a	b	c	d	e	g	h	
C	7.75	4.75	6.10	10.20	5.40	-	-	9.30
F	7.75	4.75	6.10	-	-	11.60	10.90	12.60

3.1 Intended use

Responsibility for the use of the measuring devices with regard to suitability, intended use and corrosion resistance of the used materials against the measured fluid lies solely with the operator.

The manufacturer is not liable for any damage resulting from improper use or use for other than the intended purpose.

The **OPTISONIC 4400** is designed exclusively for bi-directional measurements on conductive and / or non-conductive fluids, in closed completely filled pipeline circuits. Excess of contaminations (gas, particles, 2 phases) disturb the acoustic signal and thus must be avoided.

The overall functionality of the **OPTISONIC 4400** flowmeter, is the continuous measurement of actual volume flow, mass flow, flow speed, velocity of sound, gain, SNR, totalized flow mass and diagnosis values.

3.2 General notes on installation

Inspect the packaging carefully for damages or signs of rough handling. Report damage to the carrier and to the local office of the manufacturer.

Do a check of the packing list to make sure that you have all the elements given in the order.

Look at the device nameplate to ensure that the device is delivered according to your order. Check for the correct supply voltage printed on the nameplate.

3.3 General requirements

The following precautions must be taken to ensure reliable installation.

- *Make sure that there is adequate space to the sides.*
- *Protect the signal converter from direct sunlight and install a sun shade if necessary.*
- *Signal converters installed in control cabinets require adequate cooling, e.g. by fan or heat exchanger.*
- *Do not expose the signal converter to intense vibration. The flowmeters are tested for a vibration level in accordance with IEC 68-2-6.*

3.3.1 Vibration

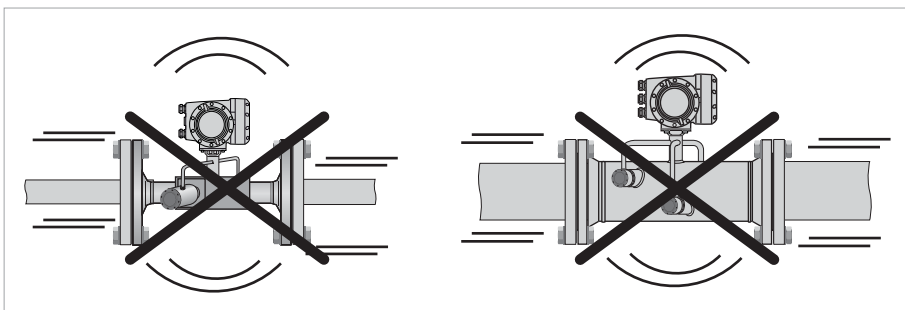

Figure 3-1: Avoid vibrations

In case of expected vibrations, please install a field version.

3.3.2 Corrosion preservation

*The corrosion preservation applied is valid for three months after the manufacturing date. To prevent corrosion of the carbon steel flow sensor **after** installation in the pipe, corrosion prevention has to be applied.*

3.4 Installation conditions

3.4.1 Inlet and outlet

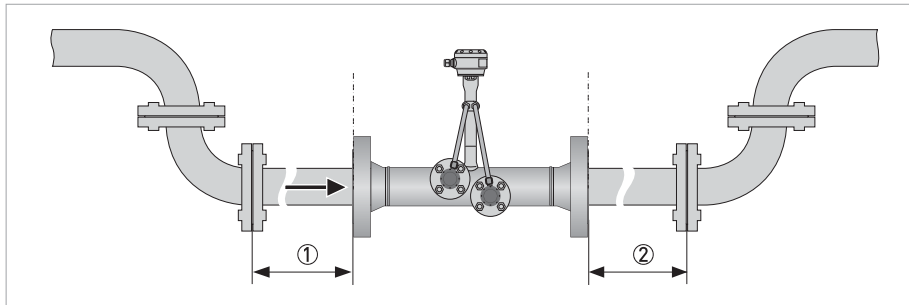

Figure 3-2: Recommended inlet and outlet

- ① Refer to chapter "Bends in 2 or 3 dimensions"
- ② ≥ 3 DN

3.4.2 Bends in 2 or 3 dimensions

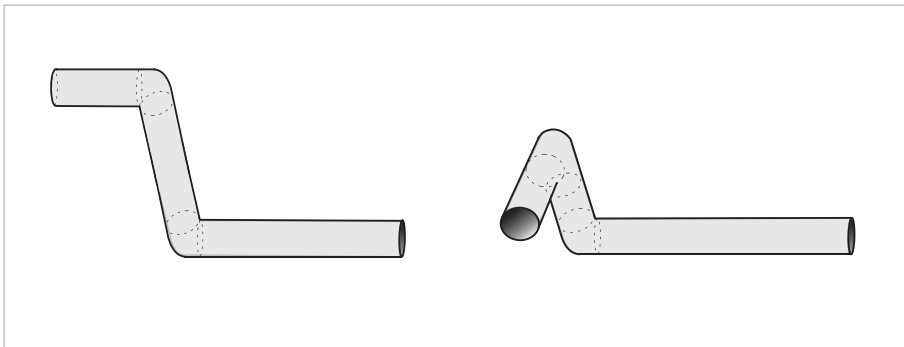

Figure 3-3: Inlet when using 2 and/or 3 dimensional bends in front of the flowmeter

Inlet length:

for 2 path using bends in 2 dimensions: ≥ 10 DN; when having bends in 3 dimensions: ≥ 15 DN
 for 1 path using bends in 2 dimensions: ≥ 20 DN; when having bends in 3 dimensions: ≥ 25 DN

3.4.3 T-section

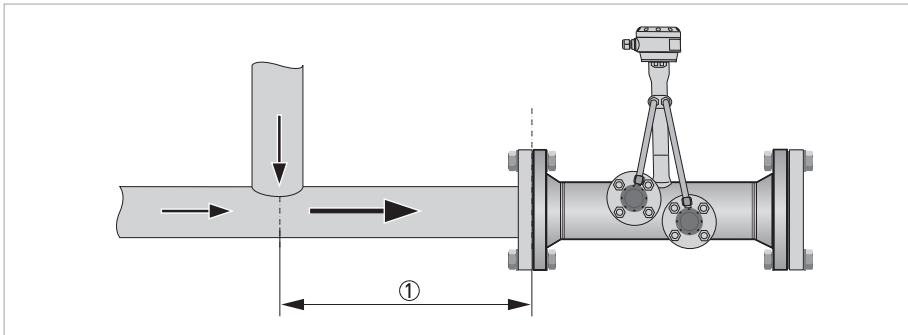

Figure 3-4: Distance behind a T-section

① 2 path \geq 10DN, 1 path \geq 20 DN

3.5 Bends

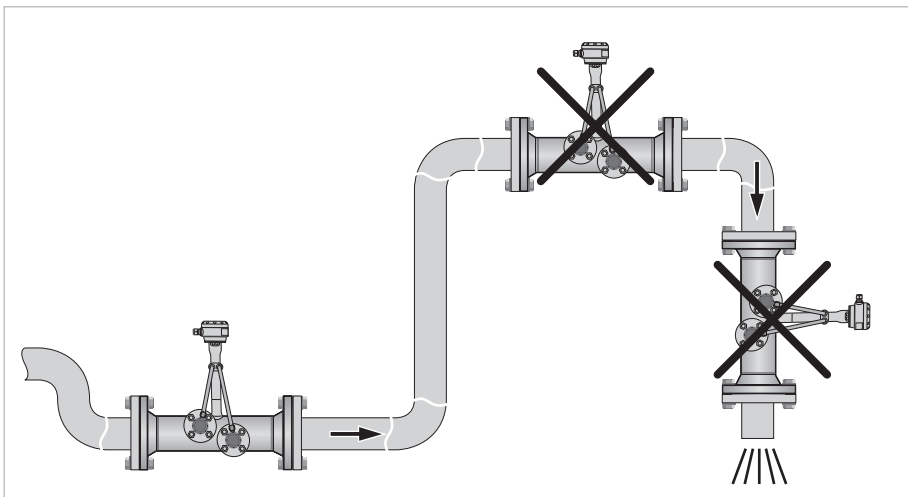

Figure 3-5: Installation in bending pipes

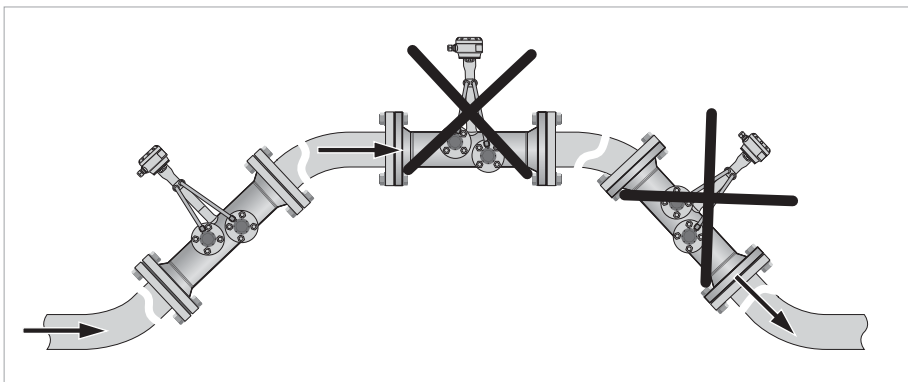

Figure 3-6: Installation in bending pipes

3.6 Open feed or discharge

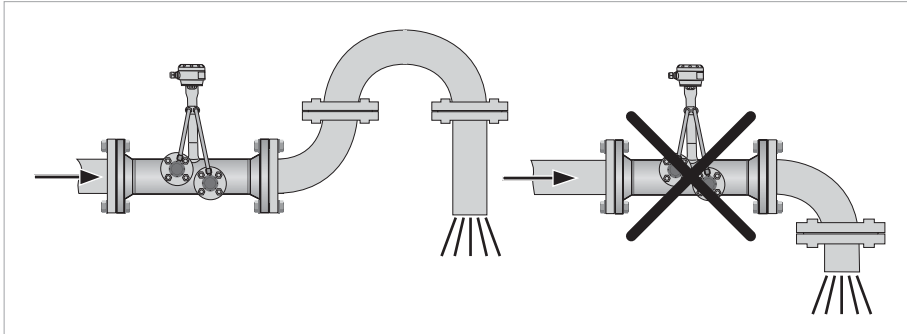

Figure 3-7: Open discharge

Install meter on a lowered section of the pipe to ensure a full pipe condition through the meter.

3.7 Position of pump

Never install flowmeter at a pump suction side in order to avoid cavitation or flashing in the flowmeter.

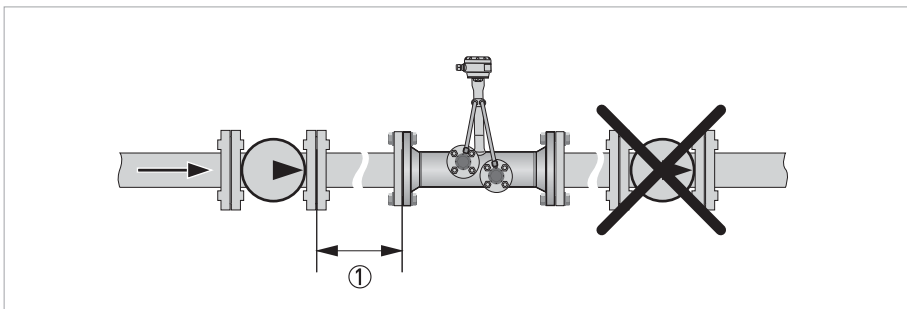

Figure 3-8: Installation behind a pump

① ≥ 30 DN

3.8 Control valve

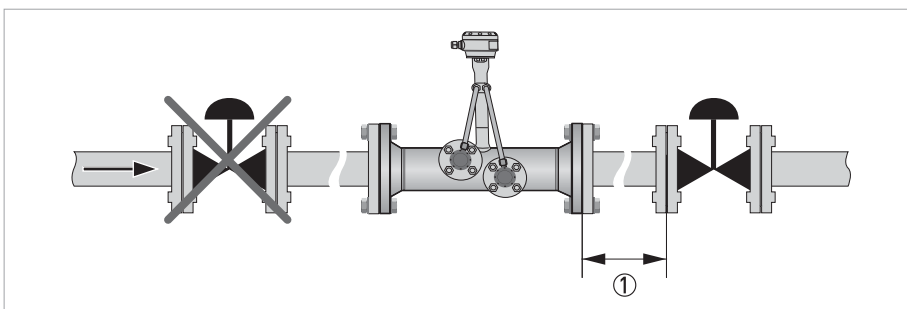

Figure 3-9: Installation in front of a control valve

① ≥ 40 DN

3.9 Down going pipeline over 5 m / 16 ft length

Install air vent downstream of the flowmeter to prevent vacuum. Although this will not harm the meter, it may cause gases to come out of solution (cavitate) and interfere with proper measurements.

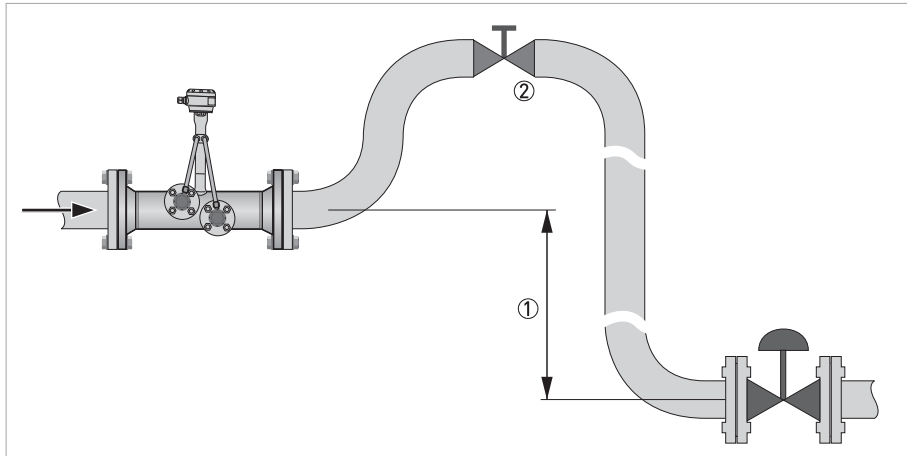

Figure 3-10: Down going pipeline over 5 m / 16 ft length

- ① ≥ 5 m / 16 ft
- ② Install air vent

3.10 Thermal insulation

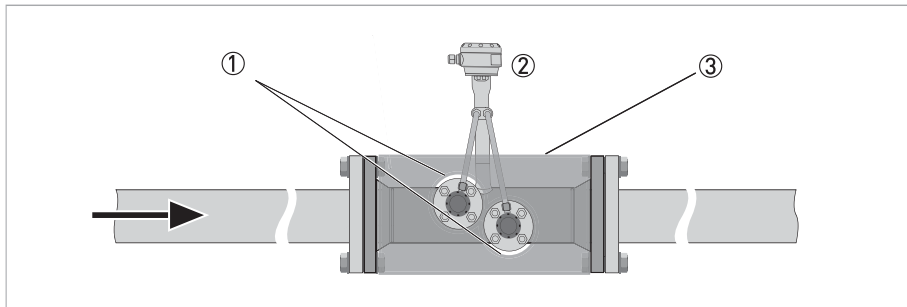

Figure 3-11: Insulation

- ① See the detailed transducer area on next page
- ② Connection box
- ③ Insulation area

The flow sensor can be insulated completely, except for the transducer piezo module(s) ① and the connection box ② to allow cooling by free air convection. The transducers can reach a temperature of up to 200 °C./ 392 °F.

See the detailed area ③ in the following illustration

For devices used in hazardous area, additional maximum temperature and insulation precautions apply. Please refer to the Ex documentation!

Detailed area for insulation

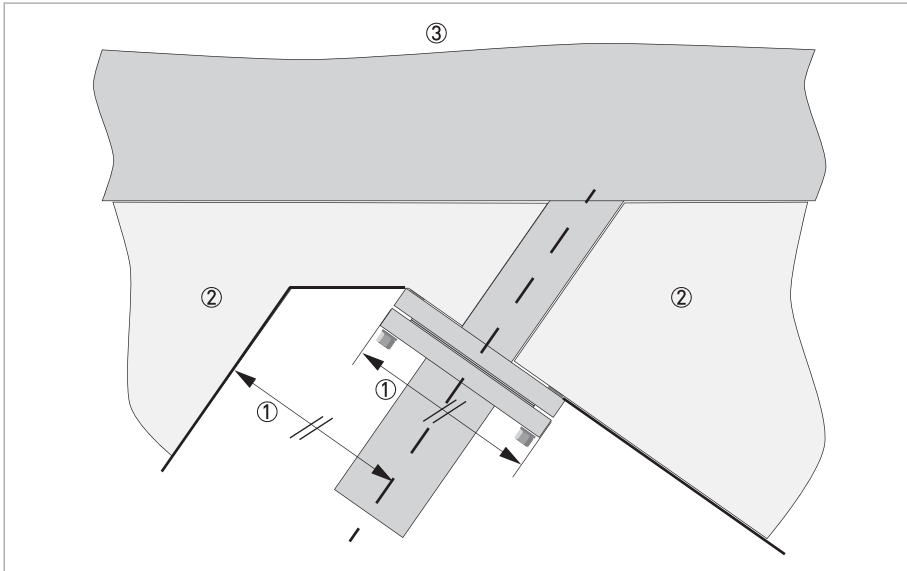

Figure 3-12: Thermal insulation

- ① Width of flange = free distance
- ② Insulation
- ③ Sensor tube

The free space (approximately 0.15 m/ 6") around the transducer housing is needed to remove the cover of the piezo module and/or remove the gaskets.

Do not turn the blue caps at the end of the transducer housing. These design caps have a click-connection

Please do not tighten (or loosen) the bolts on the flanges of the transducer. These bolts are pre set (according specifications) in the factory. See detailed information on the nameplate of the flow sensor.

3.11 Flange deviation

Max. permissible deviation of pipe flange faces:
 $L_{max} - L_{min} \leq 0.5 \text{ mm} / 0.02''$

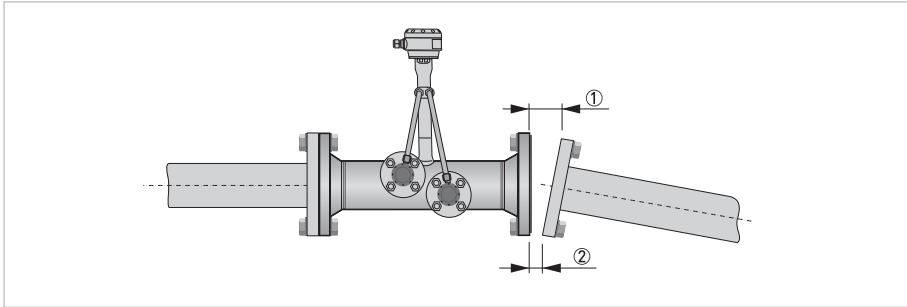

Figure 3-13: Flange deviation

- ① L_{max}
- ② L_{min}

3.12 Welding of flow sensor into the pipe

Flow sensors without flanges and/or welded ends can be welded on-site into the pipe section.

Be aware that adding too much heat when welding, can cause damage to the transducers (piezo element).

3.13 Mounting position

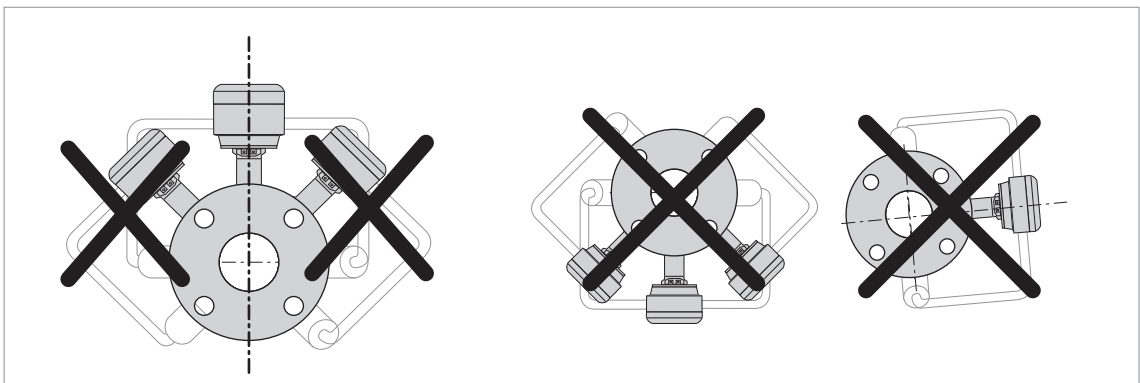

Figure 3-14: Allowed mounting position

3.14 Mounting the field housing, remote version

Assembly materials and tools are not part of the delivery. Use the assembly materials and tools in compliance with the applicable occupational health and safety directives.

3.14.1 Pipe mounting

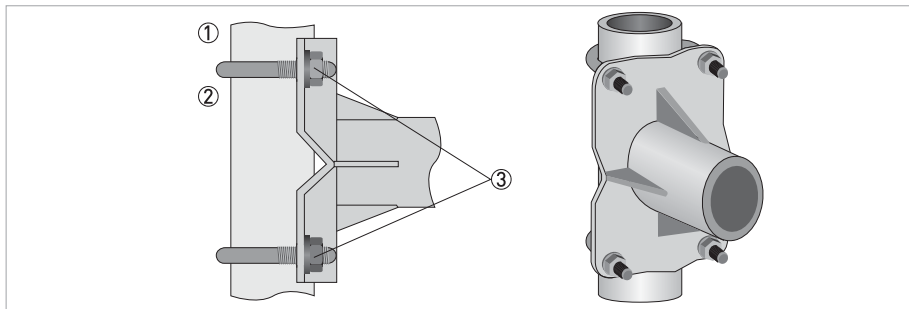

Figure 3-15: Pipe mounting of the field housing

- ① Fix the signal converter to the pipe.
- ② Fasten the signal converter using standard U-bolts and washers.
- ③ Tighten the nuts.

3.14.2 Wall mounting

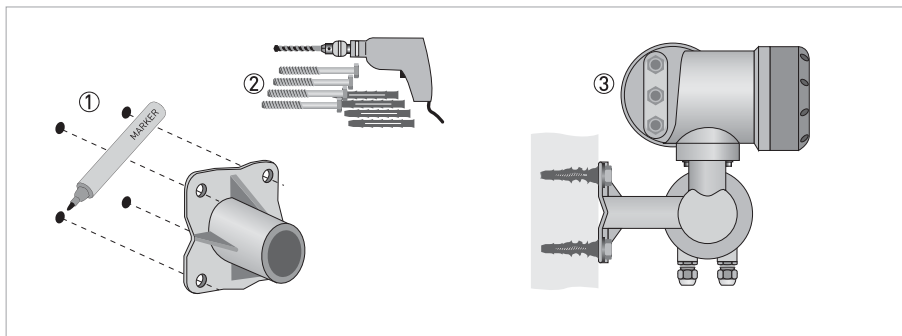
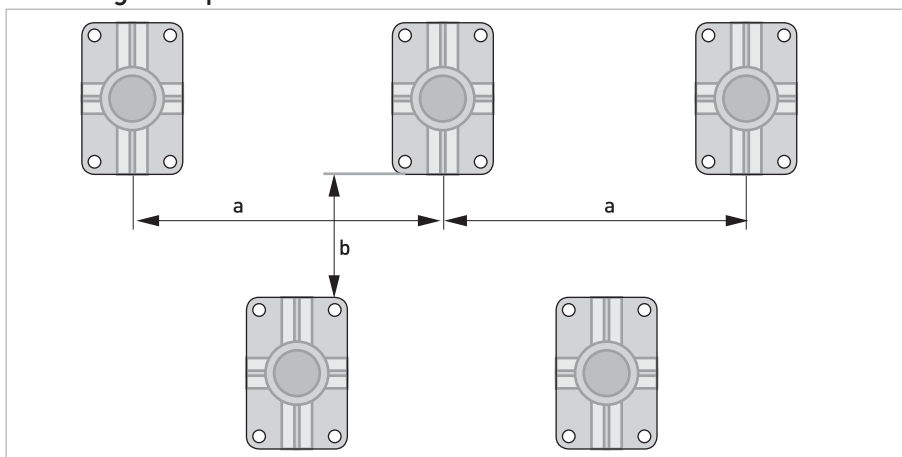

Figure 3-16: Wall mounting of the field housing

- ① Prepare the holes with the aid of the mounting plate.
- ② Use the mounting material and tools in compliance with the applicable occupational health and safety directives.
- ③ Fasten the housing securely to the wall.

Mounting multiple devices next to each other



$a \geq 600 \text{ mm} / 23.6''$
 $b \geq 250 \text{ mm} / 9.8''$

3.14.3 Turning the display of the field housing version

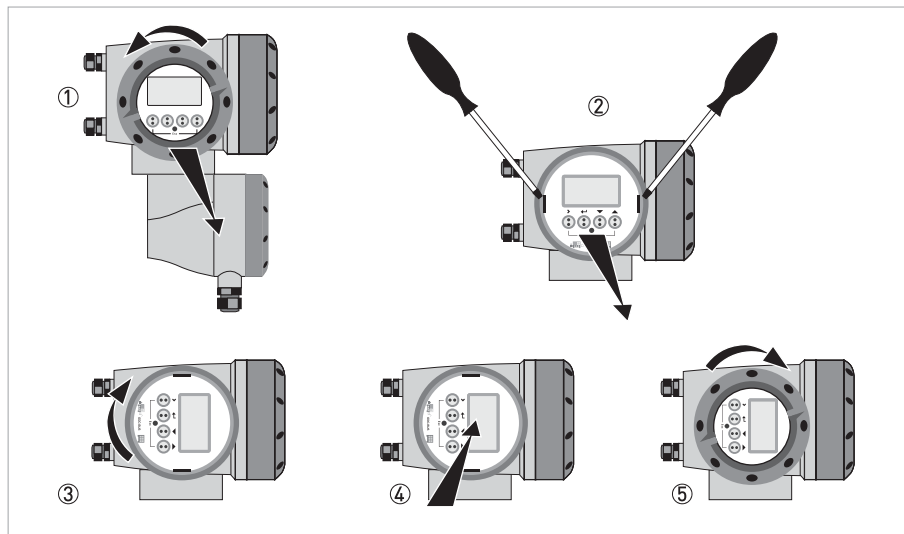

Figure 3-17: Turning the display of the field housing version

The display of the field housing version can be turned in 90° increments

- ① Unscrew the cover from the display and operation control unit.
- ② Using a suitable tool, pull out the two metal puller devices to the left and right of the display.
- ③ Pull out the display between the two metal puller devices and rotate it to the required position.
- ④ Slide the display and then the metal puller devices back into the housing.
- ⑤ Re-fit the cover and tighten it by hand.

The ribbon cable of the display must not be folded or twisted repeatedly.

Each time a housing cover is opened, the thread should be cleaned and greased. Use only resin-free and acid-free grease.

Ensure that the housing gasket is properly fitted, clean and undamaged.

4.1 Signal cable (remote versions only)

The flow sensor is connected to the signal converter via one signal cable, with 2 or 4 (marked) inner coax cables for the connection of one or two acoustic paths.

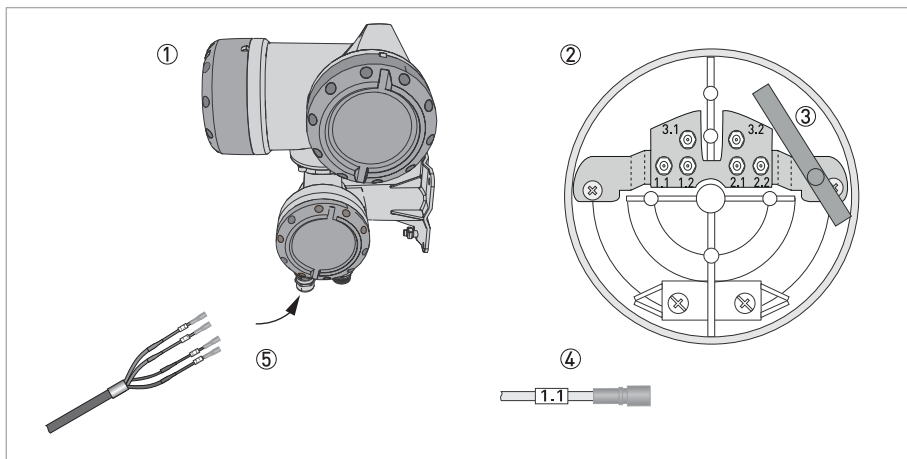

Figure 4-1: Construction of field version

- ① Signal converter
- ② Open connection box
- ③ Tool for releasing connectors
- ④ Marking on cable
- ⑤ Insert cable(s) into terminal compartment

Connect the cable on connector with similar numeral marking

4.2 Power supply

When this device is intended for permanent connection to the mains. It is required (for example for service) to mount an external switch or circuit breaker near the device for disconnection from the mains. It shall be easily reachable by the operator and marked as the disconnecting the device for this equipment. The switch or circuit breaker and wiring has to be suitable for the application and shall also be in accordance with the local (safety) requirements of the (building) installation (e.g. IEC 60947-1 / -3)

For devices used in hazardous areas, additional safety notes apply; please refer to the Ex documentation.

The power terminals in the terminal compartments are equipped with additional hinged lids to prevent accidental contact.

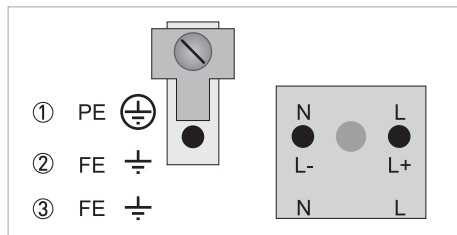

- ① 100...230 VAC (-15% / +10%), 22 VA
- ② 24 VDC (-55% / +30%) 12 W
- ③ 24 VAC/DC (AC: -15% / +10%; DC: -25% / +30%), 22 VA or 12 W

The device must be grounded in accordance with regulations in order to protect personnel against electric shocks.

100...230 VAC (tolerance range: -15% / +10%)

- Note the power supply voltage and frequency (50...60 Hz) on the nameplate.
- The protective ground terminal **PE** of the power supply must be connected to the separate U-clamp terminal in the terminal compartment of the signal converter

240 VAC+5% is included in the tolerance range.

24 VDC (tolerance range: -55% / +30%)

24 VAC/DC (tolerance ranges: AC: -15% / +10%; DC: -25% / +30%)

- Note the data on the nameplate!
- For measurement process reasons, a functional ground **FE** must be connected to the separate U-clamp terminal in the terminal compartment of the signal converter.
- When connecting to functional extra-low voltages, provide a facility for protective separation (PELV) (acc. to VDE 0100 / VDE 0106 and/or IEC 364 / IEC 536 or relevant national regulations).

4.3 Input and outputs, overview

4.3.1 Combinations of the inputs/outputs (I/Os)

This signal converter is available with various input/output combinations.

Basic version

- Has 1 current output, 1 pulse output and 2 status outputs / limit switches.
- The pulse output can be set as status output/limit switch and one of the status outputs as a control input.

Ex i version

- Depending on the task, the device can be configured with various output modules.
- Current outputs can be active or passive.
- Optionally available also with Foundation Fieldbus and Profibus PA

Modular version

- Depending on the task, the device can be configured with various output modules.

Bus systems

- The device allows intrinsically safe and non intrinsically safe bus interfaces in combination with additional modules.
- For connection and operation of bus systems, note the supplementary instructions.

Ex option

- For hazardous areas, all of the input/output variants for the housing designs C and F can be delivered with terminal compartment in Ex d (pressure-resistant casing) or Ex e (increased safety).
- For connection and operation of Ex devices, note the supplementary instructions.

4.3.2 Description of the CG-number

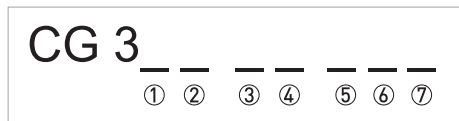

Figure 4-2: Marking (CG number) of the electronics module and input/output variants

- ① ID number:
- ② ID number: 0 = standard
- ③ Power supply option
- ④ Display (language versions)
- ⑤ Input/output version (I/O)
- ⑥ 1st optional module for connection terminal A
- ⑦ 2nd optional module for connection terminal B

The last 3 digits of the CG number (⑤, ⑥ and ⑦) indicate the assignment of the terminal connections. Please refer to the following examples.

CG 350 xx 100	100...230 VAC & standard display; basic I/O: I_a or I_p & S_p/C_p & S_p & P_p/S_p
CG 350 xx 7FK	100...230 VAC & standard display; modular I/O: I_a & P_N/S_N and optional module P_N/S_N & C_N

Description of abbreviations and CG identifier for possible optional modules on terminals A and B

Abbreviation	Identifier for CG No.	Description
I_a	A	Active current output
I_p	B	Passive current output
P_a / S_a	C	Active pulse output, frequency output, status output or limit switch (changeable)
P_p / S_p	E	Passive pulse output, frequency output, status output or limit switch (changeable)
P_N / S_N	F	Passive pulse output, frequency output, status output or limit switch acc. to NAMUR (changeable)
C_a	G	Active control input
C_p	K	Passive control input
C_N	H	Active control input to NAMUR Signal converter monitors cable breaks and short circuits acc. to EN 60947-5-6. Errors indicated on LC display. Error messages possible via status output.
-	8	No additional module installed
-	0	No further module possible

4.3.3 Fixed, non-alterable input/output versions

This signal converter is available with various input/output combinations.

- The grey boxes in the tables denote unassigned or unused connection terminals.
- In the table, only the final digits of the CG no. are depicted.
- Connection terminal A+ is only operable in the basic input/output version.

CG-No.	Connection terminals								
	A+	A	A-	B	B-	C	C-	D	D-

Basic in-/output (I/O) (Standard)

1 0 0		$I_p + \text{HART}^{\text{®}}$ passive ①	S_p / C_p passive ②	S_p passive	P_p / S_p passive ②
	$I_a + \text{HART}^{\text{®}}$ active ①				

Ex-i in-/outputs (Option)

2 0 0				$I_a + \text{HART}^{\text{®}}$ active	P_N / S_N NAMUR ②
3 0 0				$I_p + \text{HART}^{\text{®}}$ passive	P_N / S_N NAMUR ②
2 1 0		I_a active	P_N / S_N NAMUR C_p passive ②	$I_a + \text{HART}^{\text{®}}$ active	P_N / S_N NAMUR ②
3 1 0		I_a active	P_N / S_N NAMUR C_p passive ②	$I_p + \text{HART}^{\text{®}}$ passive	P_N / S_N NAMUR ②
2 2 0		I_p passive	P_N / S_N NAMUR C_p passive ②	$I_a + \text{HART}^{\text{®}}$ active	P_N / S_N NAMUR ②
3 2 0		I_p passive	P_N / S_N NAMUR C_p passive ②	$I_p + \text{HART}^{\text{®}}$ passive	P_N / S_N NAMUR ②

① Function changed by reconnecting

② Changeable

4.3.4 Alterable input/output versions

This signal converter is available with various input/output combinations.

- The grey boxes in the tables denote unassigned or unused connection terminals.
- In the table, only the final digits of the CG no. are depicted.
- Term. = (connection) terminal

CG no.	Connection terminals								
	A+	A	A-	B	B-	C	C-	D	D-

Modular IOs (option)

4 __		max. 2 optional modules for term. A + B	I _a + HART® active	P _a / S _a active ①
8 __		max. 2 optional modules for term. A + B	I _p + HART® passive	P _a / S _a active ①
6 __		max. 2 optional modules for term. A + B	I _a + HART® active	P _p / S _p passive ①
B __		max. 2 optional modules for term. A + B	I _p + HART® passive	P _p / S _p passive ①
7 __		max. 2 optional modules for term. A + B	I _a + HART® active	P _N / S _N NAMUR ①
C __		max. 2 optional modules for term. A + B	I _p + HART® passive	P _N / S _N NAMUR ①

PROFIBUS PA/DP

D __		max. 2 optional modules for term. A + B	PA+ (2)	PA- (2)	PA+ (1)	PA- (1)
F __		max. 2 optional modules for term. A + B	PA+ (2)	PA- (2)	PA+ (1)	PA- (1)

FOUNDATION Fieldbus (option)

E __		max. 2 optional modules for term. A + B	V/D+ (2)	V/D- (2)	V/D+ (1)	V/D- (1)
------	--	---	----------	----------	----------	----------

Modbus (option)

G __ ②		max. 2 optional modules for term. A + B		Commo n	Sign. B (D1)	Sign. A (D0)
--------	--	---	--	------------	-----------------	-----------------

① changeable

② not activated bus terminator

Please fill in this form and fax or email it to your local representative. Please include a sketch of the pipe layout as well, including the X, Y, Z dimensions.

5.1 Device Configuration Form

Customer information:

Date:
Submitted by:
Company:
Address:
Telephone:
Fax:
E-mail:

Flow application data:

Reference information (name, tag etc):
New application Existing application, currently using:
Measurement objective:
Medium
Liquid:
Gas content:
Solids content:
Density:
Velocity of sound:
Flowrate
Normal:
Minimum:
Maximum:
Temperature
Normal:
Minimum:
Maximum:
Pressure
Normal:
Minimum:
Maximum:

Piping details

Nominal pipe size:
Inner / Outer diameter:
Wall thickness / schedule:
Pipe material:
Straight inlet / outlet section (DN):
Upstream situation (elbows, valves, pumps):
Flow orientation (vertical up / horizontal / vertical down / other):

Environment details

Corrosive atmosphere:
Sea water:
High humidity (% R.H.)
Nuclear (radiation):
Hazardous area:
Additional details:

Hardware requirements:

Accuracy requested (percentage of rate):
Power supply (voltage, AC / DC):
Analog output (4-20 mA)
Pulse (specify minimum pulse width, pulse value):
Digital protocol:
Options:
Remote mounted signal converter:
Specify cable length:
Accessories:

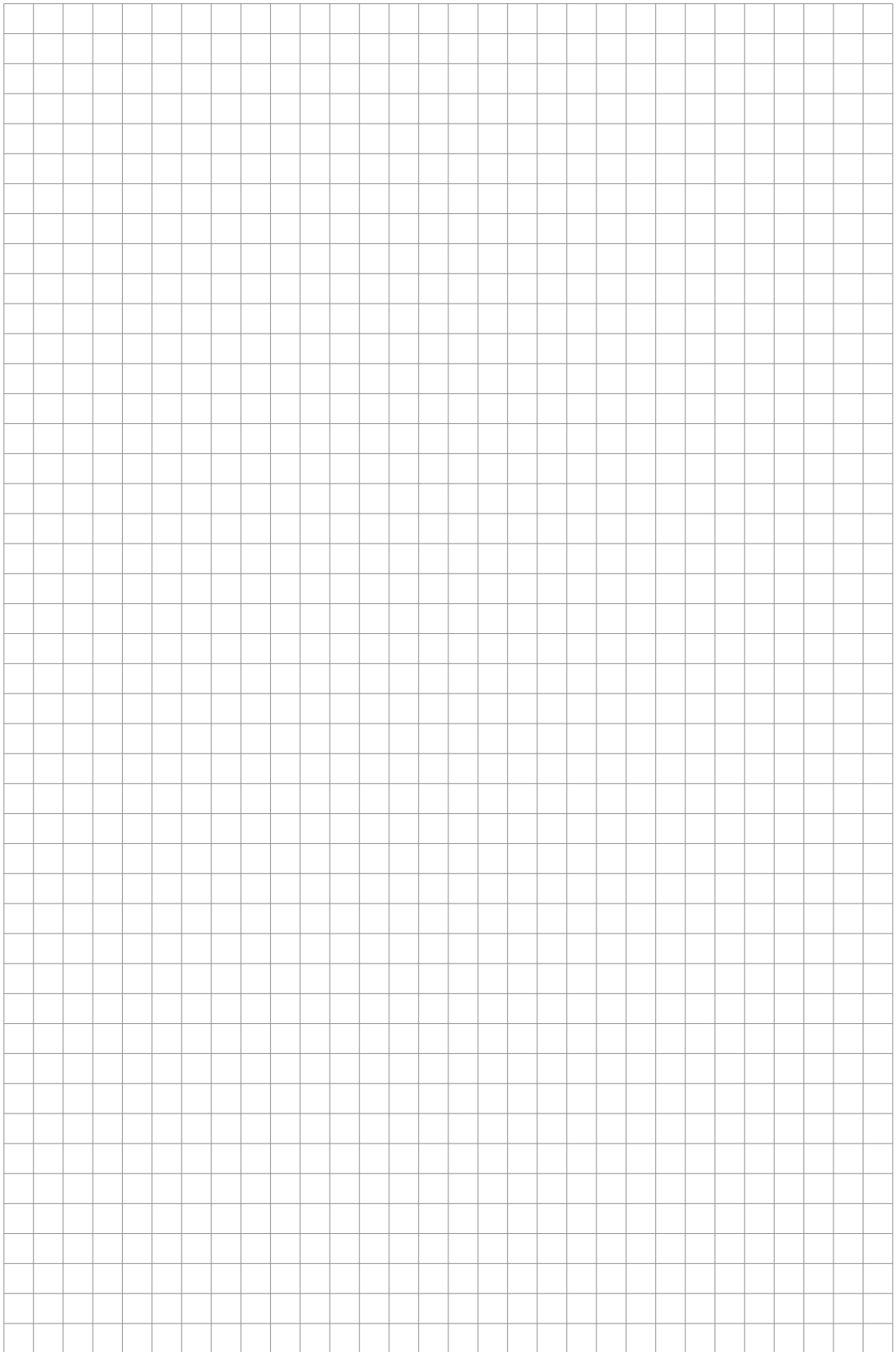



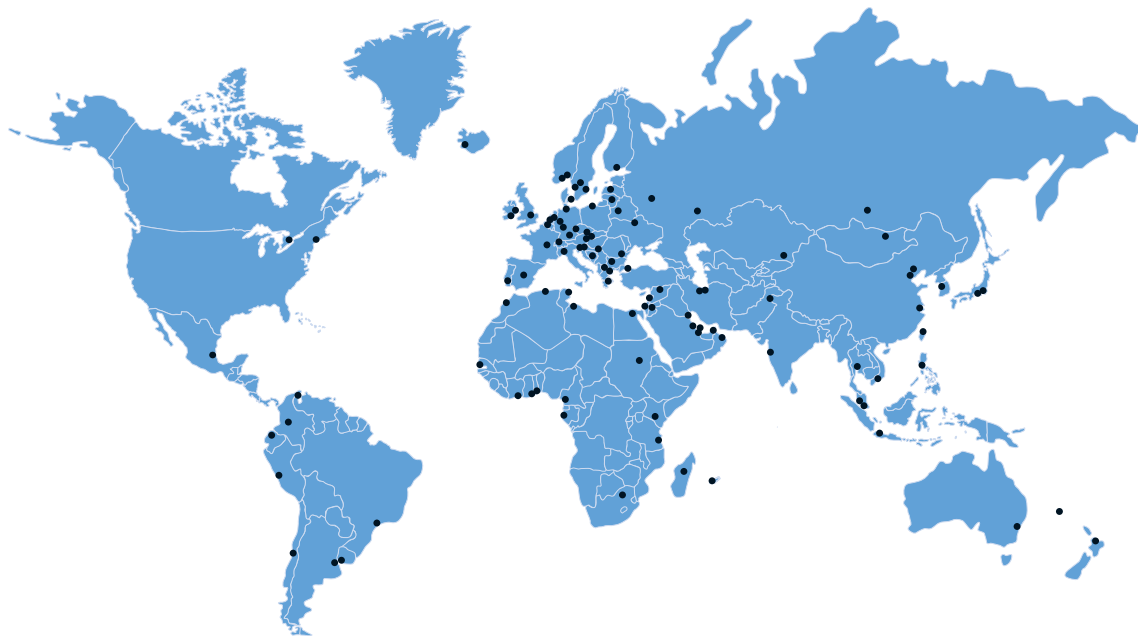

KROHNE – Process instrumentation and measurement solutions

- Flow
- Level
- Temperature
- Pressure
- Process Analysis
- Services

Head Office KROHNE Messtechnik GmbH
Ludwig-Krohne-Str. 5
47058 Duisburg (Germany)
Tel.: +49 203 301 0
Fax: +49 203 301 10389
info@krohne.com

The current list of all KROHNE contacts and addresses can be found at:
www.krohne.com

KROHNE