

Diaphragm Valve Type 514, 515, 517, 519



General

- **Size:** ½"–2"
- **Material:** PVC, CPVC, PROGEF® Standard® PP, PROGEF® Natural PPn, ABS, SYGEF® Standard PVDF, SYGEF® Plus PVDF-HP
- **Diaphragm:** EPDM, FPM, NBR, PTFE/EPDM, PTFE/FPM, PTFE-HP/EPDM, PTFE-HP/FPM
- **End Connection:** Solvent cement socket, threaded, flanged, fusion spigot union, fusion socket union, fusion spigot
- **Top Works:** Threaded connection to valve body
- **Position Indicator:** Integrated, graduated
- **Handle:** Lockable
- **Mounting:** Stainless steel inserts

Key Certifications

- **FDA CFR 21 177.1520:** PP and PVDF
- **FDA CFR 21 177.2600:** EPDM and FPM
- **FDA CFR 21 177.1550:** PTFE
- **USP 25 Class VI (physiological non-toxic):** PP and PVDF

Sample Specification

The 5-Series Diaphragm Valve family shall include the Type 514, 515, 517 and 519. The Type 514 body shall be true union. The Type 515 body shall be spigot. The Type 517 body shall be spigot and the end connection shall be flanged. The Type 519 body shall be lateral style spigot. All 5-Series Diaphragm Valves shall be bidirectional. The bonnet to body connection shall be threaded. The handle shall be lockable. The diaphragm material shall be indicated by a color specific insert. The stroke shall be indicated by a graduated indicator. Type 517 ANSI versions shall meet ANSI B16.5 150lb standards. All 5-Series Diaphragm Valves with PTFE diaphragms shall have a non-bonded elastomeric backing and utilize FPM face seals if required. All valves shall be tested in accordance to ISO9393 and designed to ISO16138 standards. All valves shall be manufactured under ISO9001 for Quality and ISO14001 for Environmental Management. Following assembly, every valve shall be tested and certified bubble tight exceeding Class VI standards.

Material Specification

PVC valves shall meet ASTM D1784 cell classification 12454 standards. CPVC valves shall meet ASTM D1784 cell classification 23447-B standards. PP valves shall meet ASTM D5847-14 cell classification PP0510B66851 standards. ABS valves shall meet ASTM D3965 cell classification 42222 standards. PVDF valves shall be type 1, grade 2 according to ASTM D3222 standards. Valves of all materials shall be RoHS compliant.

Definition of Valve Type



Type 514
True Union



Type 515
Spigot



Type 517
Flanged



Type 519
Zero Static

Components



Valve Components

Part	Description	Material
1	Valve body	PVC, CPVC, PP, PPn, or PVDF
2	Valve end	PVC, CPVC, PP, PPn, PE, or PVDF
3	Valve nut	PVC, CPVC, PP, PPn, or PVDF
4	Diaphragm	EPDM, FPM, NBR or PTFE
5	Diaphragm pin	Brass
6	Compressor	Glass-filled PP
7	Spindle	Brass/SS304
8	Spindle housing	Glass-filled PP
9	Position indicator	Glass-filled PP
10	Bonnet nut	Glass-filled PP
11	Bonnet	Glass-filled PP
12	Handle	Glass-filled PP
13	Handle lock	Glass-filled PP

Key Design Features

Threaded Bonnet

The 5-Series Diaphragm Valve utilizes several unique design features. The bonnet to valve body connection is threaded whereas a traditionally designed diaphragm valve utilizes metal body bolts. However when a valve is used in hot line applications, the components of the valve thermally expand and contract. The thermal expansion rate of metal is significantly less than plastics, meaning the metal body bolts of a traditionally designed diaphragm valve need to be retorqued after hot line shut downs. The bonnet to body mechanical connection of the 5-Series Diaphragm Valve is completely plastic, thus eliminating the need for retorquing.

The elimination of body bolts is ideal for applications in which corrosive chemicals are present in the atmosphere. Traditionally designed valves in these applications typically rely on exotic and expensive metal bolts to deter corrosion, when the body bolts are eliminated, this added cost is as well.



Key Design Features

True Zero Dead Leg

The Type 519 Diaphragm Valve is a truly revolutionary thermo-plastic zero static valve. The peak of the weir is molded nearly directly on the inner diameter of the main. This design virtually eliminates dead space when the branch port is closed.

Type 519 valves are available in PP, PPn and PVDF. Polypropylene versions are available in size ranges from d20xd20 to d63xd32 and PVDF versions are available in size ranges from d20xd20 to d110xd63.



Chemical Applications: Optional Features

Permeation Barrier

The 5-Series Diaphragm Valve utilizes several design features that are beneficial in chemical process applications. A commonly used diaphragm material in these applications is PTFE. All GF PTFE diaphragms are installed with a non-bonded elastomeric backing, either EPDM or FPM. The FPM backing is impregnated with approximately 15% PTFE. These diaphragms are available with all 5-Series Diaphragm Valve body materials. The backing material completely covers the PTFE diaphragm with the exception of the diaphragm pin.

One concern with diaphragm valves in chemical process applications is permeation. The 5-Series diaphragm is designed to protect against damage commonly caused by permeation. The FPM/PTFE backing provides a chemically resistant barrier to protect the mechanical components inside the bonnet. The backing protects nearly the entire PTFE diaphragm to provide maximum protection against component corrosion.



Bonnet Seal

Corrosive environments can be detrimental to valve components that are not exposed to media. This is addressed with the 5-Series Diaphragm Valve in the bonnet seals. The bonnet seal is available with all varieties of 5-Series Valves and utilizes three o-rings. One on the position indicator, one on the spindle housing and one on the bonnet nut. The combination of these o-rings seals the inner works of the valves from the atmosphere. The result of this is that there is no exposed metal to the atmosphere with the exception of the threaded mounting inserts on the base of the valve.

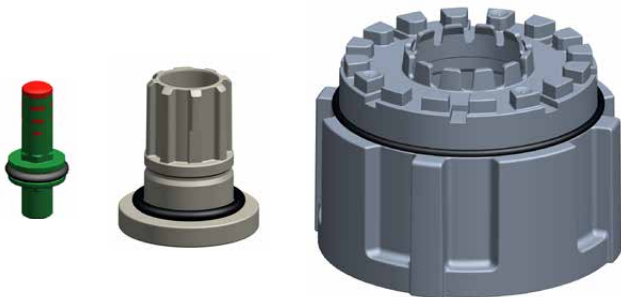

Technical Data

Pressure Temperature Curves

The following graphs are based on a 25 year lifetime water or similar media application

PVC

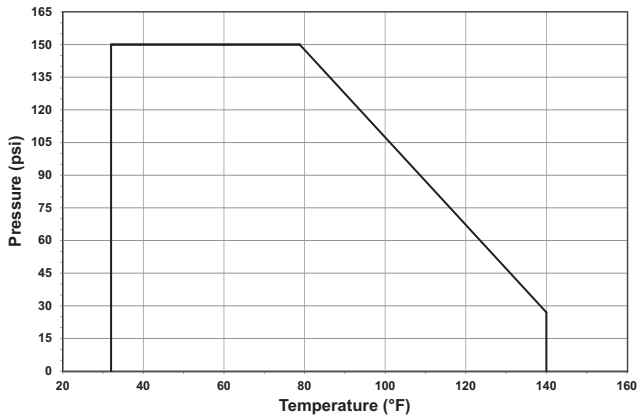

CPVC

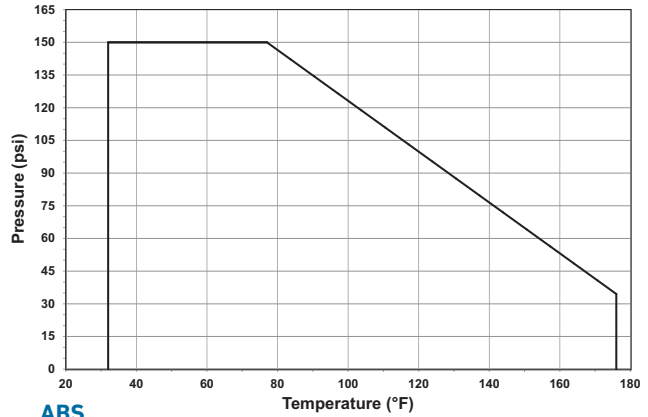

PP/PPn

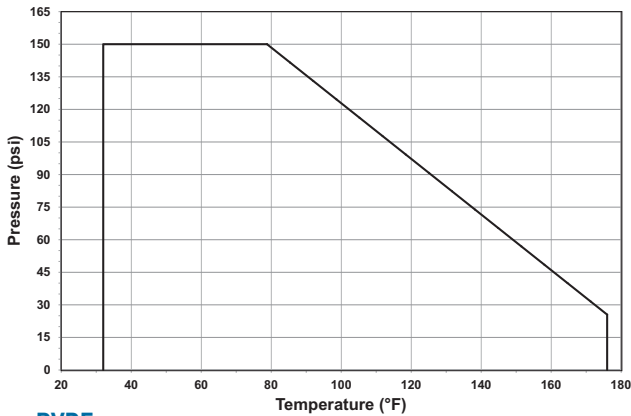

ABS

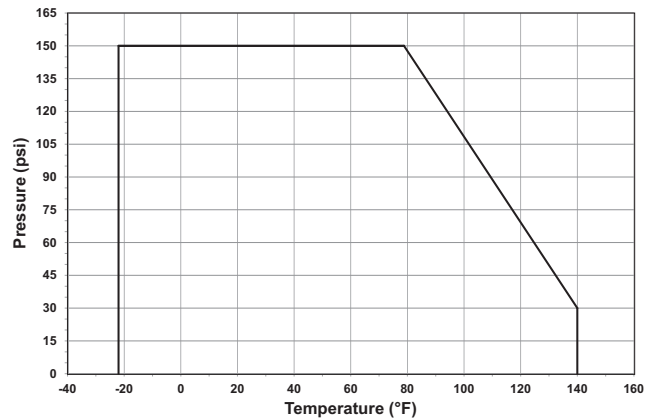

PVDF

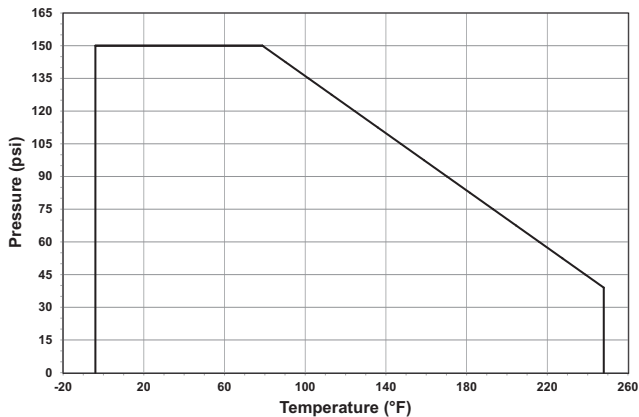

Pressure-Temperature

Material	Temperature Range (°F)	Max Pressure (psi)
PVC*	32 to 140	150
CPVC*	32 to 176	150
PP/PPn	32 to 176	150
ABS	-40 to 140	150
PVDF*	-4 to 284	150

Vacuum Service

5-Series Diaphragm Valve with an elastomeric diaphragm are rated for full vacuum service, maximum differential pressure of 15psi at 122°F. 5-Series Diaphragm Valves with a PTFE diaphragm are not rated for full vacuum service, maximum differential pressure of 8.7psi at 122°F.

High Pressure Applications: Optional Feature

The 5-Series diaphragm valve is available with a glass-filled black PPS bonnet. This high-strength, rigid material increases the rated pressure to 232psi. It is available with PVC, CPVC and PVDF bodies with EPDM, FPM or PTFE diaphragms. GF recommends that all valves fitted with this bonnet be used in water applications only.



Flow

The following information is based on water applications at 68° F

Flow Characteristics Type 514–517

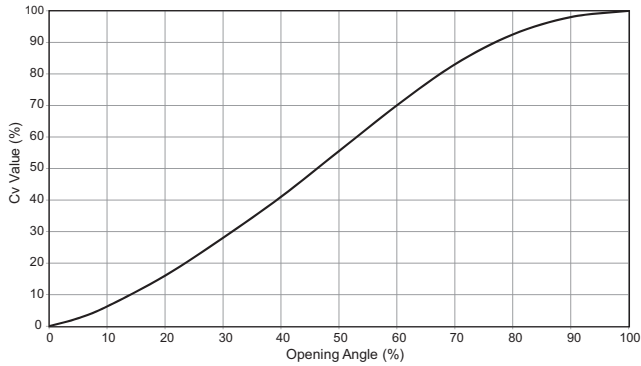

Flow Characteristics Type 519

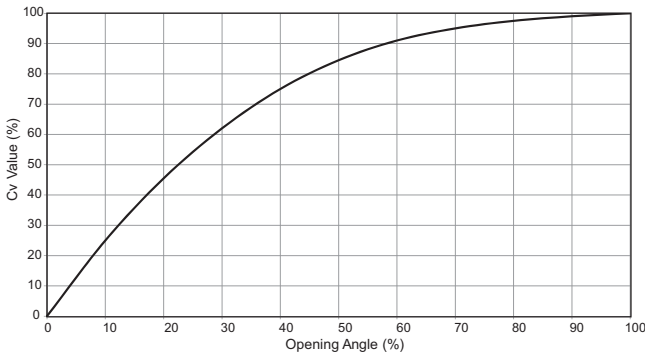

Key Design Features

Weir Design

The threaded bonnet design also eliminated the need for valve body bolt holes. This allowed GF engineers to decrease the grade of the weir and design a valve with an optimized flow path. This significantly increases the Cv value when comparing the 5-Series Valve to traditionally designed diaphragm valves.

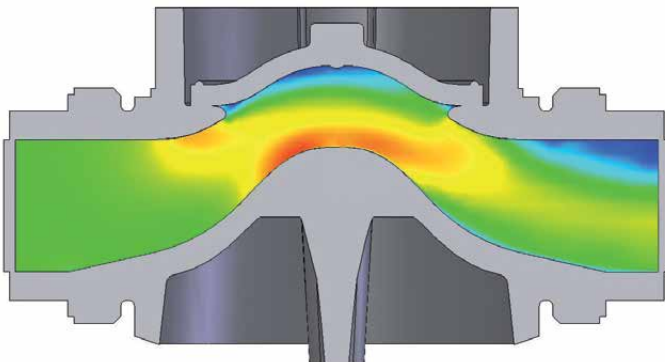

Cv Value Type 514-517

Size (inch)	d (mm)	Cv (gal/min)
1/2	20	8.4
3/4	25	18.3
1	32	32.5
1 1/4	40	51.3
1 1/2	50	85.3
2	63	116.8

Cv Value Type 519

Main (mm)	Branch (mm)	Cv (gal/min)
20	20	3.9
25	20	6.0
25	25	8.0
32	20	5.4
32	25	7.1
32	32	15.6
40	20	5.7
40	25	8.0
40	32	10.3
40	40	12.6
50	20	5.8
50	25	10.8
50	32	13.9
50	40	35.4
50	50	45.1
63	20	5.7
63	25	10.1
63	32	12.4
63	40	31.8
63	50	41.2
63	63	50.5
90	20	5.7
90	25	7.2
90	32	9.0
90	50	43.6
90	63	48.7
110	20	5.5
110	25	7.2
110	32	9.2
110	50	42.3
110	63	46.3

Dimensions

The following tables are shown in millimeters unless otherwise specified

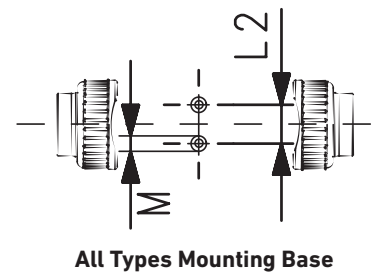
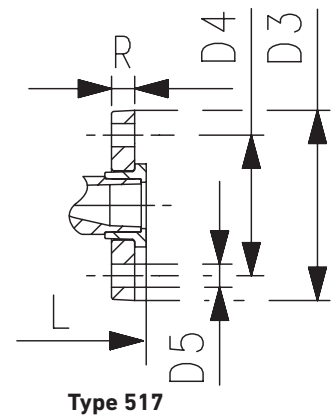
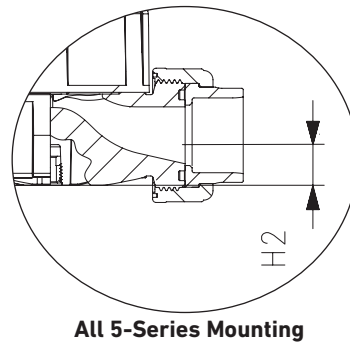
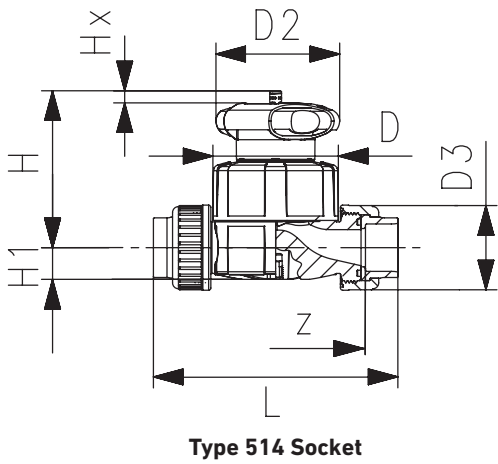

All Types

Size (inch)	d (mm)	D	D2	D3	L2	H	H1	H2	M	Hx
1/2	20	65	65	43	25	73	14	12	M6	7
3/4	25	80	65	51	25	81	18	12	M6	10
1	32	88	87	58	25	107	22	12	M6	13
1 1/4	40	101	87	72	45	115	26	15	M8	15
1 1/2	50	117	135	83	45	148	32	15	M8	19
2	63	144	135	100	45	166	39	15	M8	25

Type 514 PVC/CPVC

Size (inch)	IPS Socket		Threaded NPT	
	L	z	L	z
1/2	136	96	128	94
3/4	160	114	152	116
1	176	122	166	122
1 1/4	198	140	192	143
1 1/2	232	160	222	176
2	268	190	266	218

Type 517 PVC/CPVC

Size (inch)	ANSI Flanged				
	L	D3 (inch)	D4 (inch)	D5 (inch)	R (inch)
1/2	130	3.74	2.36	0.63	0.63
3/4	150	4.13	2.76	0.63	0.67
1	160	4.53	3.11	0.63	0.71
1 1/4	180	5.51	3.5	0.63	0.63
1 1/2	200	5.91	3.86	0.63	0.71
2	230	6.5	4.76	0.75	0.71

Type 514 ABS

d(mm)	Metric Socket	
	L	z
20	128	96
25	152	114
32	166	122
40	192	140
50	222	160
63	266	190

Type 517 ABS

Size (inch)	ANSI Flanged				
	L	D3 (inch)	D4 (inch)	D5 (inch)	R (inch)
1/2	130	3.74	2.36	0.63	0.63
3/4	150	4.13	2.76	0.63	0.67
1	160	4.53	3.11	0.63	0.71
1 1/4	180	5.51	3.5	0.63	0.63
1 1/2	200	5.91	3.86	0.63	0.71
2	230	6.5	4.76	0.75	0.71

Dimensions

The following tables are shown in millimeters unless otherwise specified

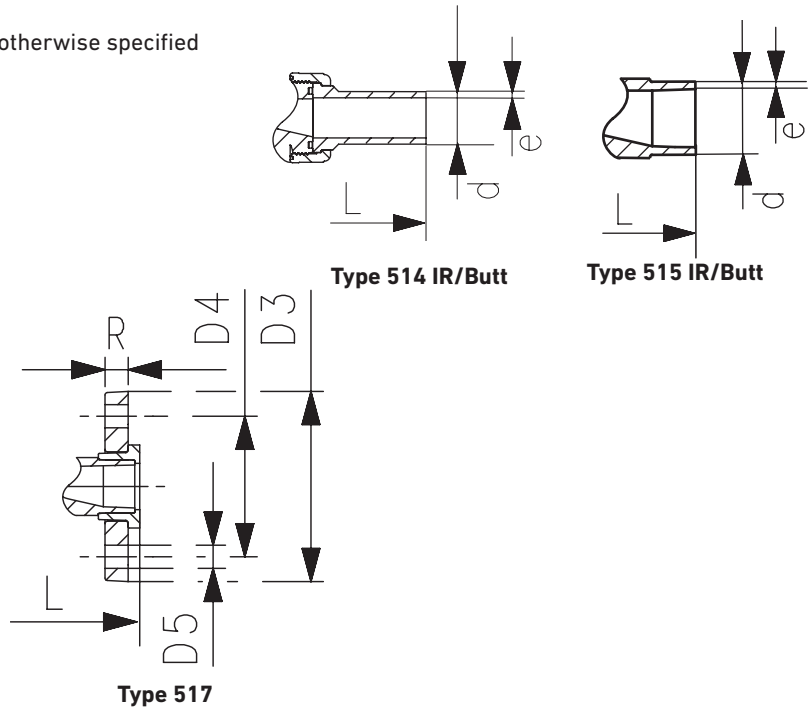
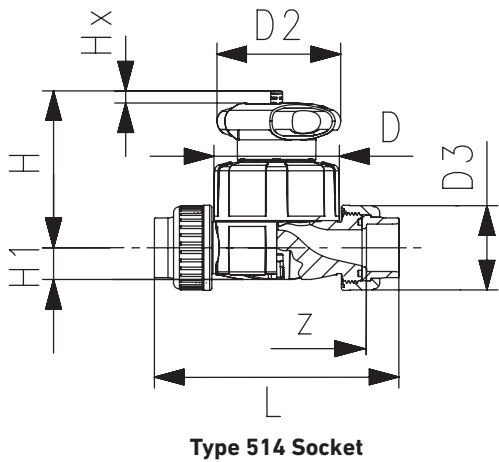

Type 514 PP

d(mm)	Metric IR/Butt		Metric Socket		Threaded NPT	
	L	e	L	z	L	z
20	196	1.9	128	100	132	98
25	221	2.3	150	118	154	118
32	234	2.9	162	126	172	128
40	260	3.7	184	144	196	148
50	284	4.6	210	164	222	176
63	321	5.8	248	194	266	218

Type 515 PP

d(mm)	Metric IR/Butt	
	L	e
20	124	1.9
25	144	2.3
32	155	2.9
40	176	3.7
50	193	4.6
63	223	5.8

Type 517 PP

Size (inch)	ANSI Flanged				
	L	D3 (inch)	D4 (inch)	D5 (inch)	R (inch)
1/2	130	3.74	2.36	0.63	0.63
3/4	150	4.13	2.76	0.63	0.67
1	160	4.53	3.11	0.63	0.71
1 1/4	180	5.51	3.5	0.63	0.63
1 1/2	200	5.91	3.86	0.63	0.71
2	230	6.5	4.76	0.75	0.71

Type 517 PVDF

Size (inch)	ANSI Flanged				
	L	D3 (inch)	D4 (inch)	D5 (inch)	R (inch)
1/2	130	3.74	2.36	0.63	0.63
3/4	150	4.13	2.76	0.63	0.67
1	160	4.53	3.11	0.63	0.71
1 1/4	180	5.51	3.5	0.63	0.63
1 1/2	200	5.91	3.86	0.63	0.71
2	230	6.5	4.76	0.75	0.71

Type 514 PVDF

d(mm)	Metric IR/Butt		Metric Socket		Threaded NPT	
	L	e	L	z	L	z
20	196	1.9	128	100	132	98
25	220	1.9	150	118	154	118
32	234	2.4	162	126	172	128
40	258	2.4	184	144	196	150
50	284	3.0	210	164	222	176
63	320	3.0	248	194	266	218

Type 515 PVDF

d(mm)	Metric IR/Butt	
	L	e
20	124	1.9
25	144	1.9
32	155	2.4
40	176	2.4
50	193	3.0
63	223	3.0

Dimensions

The following tables are shown in millimeters unless otherwise specified

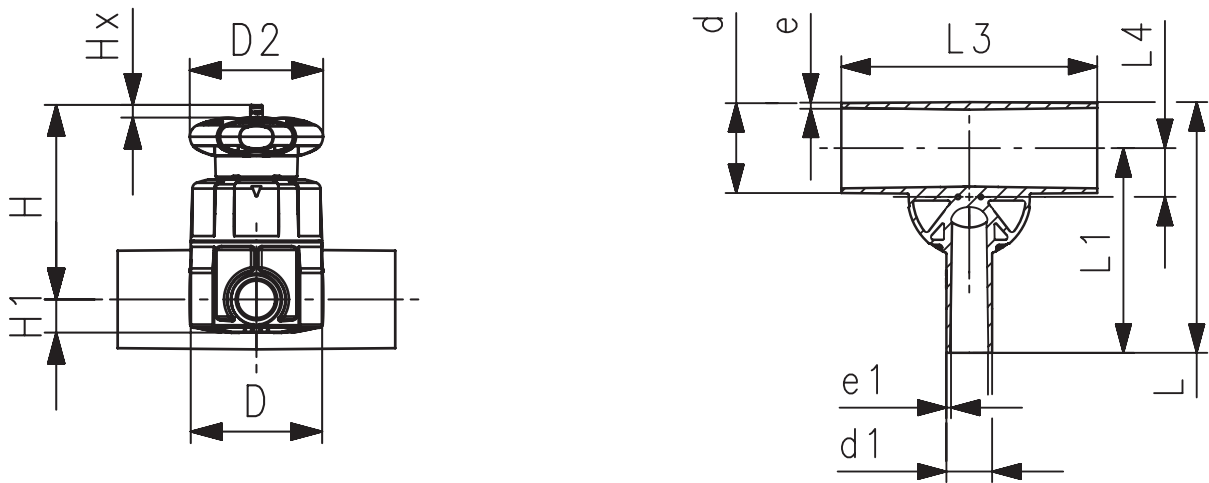

Type 519 Zero Static

d-d1 (mm)	Valve (mm)	D	D2	L	L1	L3	L4	H	H1	Hx	e PVDF	e1 PVDF	e PP/ PPn	e1 PP/ PPn
20-20	20	65	65	117	96	162	12	75	14	7	1.9	1.9	1.9	1.9
25-20	25	80	65	133	108	162	16	80	18	10	1.9	1.9	2.3	1.9
25-25	25	80	65	133	108	162	16	80	18	10	1.9	1.9	2.3	2.3
32-20	25	80	65	142	120	162	19	84	22	10	2.4	1.9	2.9	1.9
32-25	25	80	65	142	120	162	19	84	22	10	2.4	1.9	2.9	2.3
32-32	32	88	87	145	120	160	19	107	22	13	2.4	2.4	2.9	2.9
40-20	32	88	87	149	128	180	23	115	22	13	2.4	1.9	3.7	1.9
40-25	32	88	87	149	128	180	23	115	22	13	2.4	1.9	-	-
40-32	32	88	87	149	128	180	23	115	22	13	2.4	2.4	-	-
40-40	32	88	87	174	153	180	23	115	22	13	2.4	2.4	3.7	3.7
50-20	25	80	65	160	134	180	27	97	18	10	3.0	1.9	4.6	1.9
50-25	32	88	87	160	134	180	28	120	22	13	3.0	1.9	4.6	2.3
50-32	32	88	87	160	134	180	28	120	22	13	3.0	2.4	4.6	2.9
50-40	63	144	135	209	169	209	33	164	32	25	3.0	2.4	-	-
50-50	63	144	135	209	169	209	33	164	32	25	3.0	3.0	-	-
63-20	25	80	65	177	144	180	33	104	18	10	3.0	1.9	5.8	1.9
63-25	32	88	87	177	144	180	35	127	22	13	3.0	1.9	5.8	2.3
63-32	32	88	87	177	144	180	35	127	22	13	3.0	2.4	5.8	2.9
63-40	63	144	135	225	192	220	39	170	39	25	3.0	2.4	-	-
63-50	63	144	135	225	192	220	39	170	39	25	3.0	3.0	-	-
63-63	63	144	135	225	192	220	39	170	39	25	3.0	3.0	-	-
90-20	32	88	87	205	159	190	47	140	22	13	4.3	1.9	-	-
90-25	32	88	87	205	159	190	47	140	22	13	4.3	1.9	-	-
90-32	32	88	87	205	159	190	47	140	22	13	4.3	2.4	-	-
90-50	63	144	135	254	207	250	51	184	39	25	4.3	3.0	-	-
90-63	63	144	135	254	207	250	51	184	39	25	4.3	3.0	-	-
110-20	32	88	87	227	171	190	56	149	22	13	5.3	1.9	-	-
110-25	32	88	87	227	171	190	56	149	22	13	5.3	1.9	-	-
110-32	32	88	87	227	171	190	56	149	22	13	5.3	2.4	-	-
110-50	63	144	135	276	219	250	60	194	39	25	5.3	3.0	-	-
110-63	63	144	135	276	219	250	60	194	39	25	5.3	3.0	-	-