



Level



Pressure



Flow



Temperature



Liquid
Analysis



Registration



Systems
Components



Services



Solutions

Technical Information

Turbimax CUS31

Turbidity sensor

Installation and immersion sensor for drinking water and industrial water according to the 90° scattered light method



Application

- All phases of drinking water processing
- Coagulation and flocculation
- Filter rupture monitoring
- Filter backwash
- Control of clear rinsing cycles
- Monitoring of phase separation processes
- Boiler feedwater
- Monitoring of cooling water
- Monitoring of surface waters
- Outlet monitoring of sewage treatment plants
- Monitoring of industrial water discharge
- Recycling of industrial water

Your benefits

- All-purpose:
 - Direct installation in water pipes
 - Suitable as a drinking water sensor for every installation with a wall distance greater than 8 cm (3")
 - Measurement under pressure to avoid degassing
 - Integrated temperature measurement
 - Permissible distance between sensor and transmitter: 200 m (660 ft)
- Standardized and simple:
 - Measurement according to EN 27027 / ISO 7027
 - Commissioning without formazine
 - Factory calibration ("plug and play")
- Cost saving and safe:
 - Inclined plain sensor surface uses medium flow to increase the self-cleaning effect and repels air bubbles
 - Wiper unit can be retrofitted
 - Self-monitoring and plausibility check
 - Scratch-resistant sapphire glass measuring window

Function and system design

Measuring principle

Turbidity measurement

For turbidity measurement a light beam is sent through the medium and is diverted from its original direction by optically denser particles, e.g. solid matter particles.

Function

Nephelometric measuring principle 90° NIR scattered light according to EN 27027

The 90° scattered light method with a wavelength in the near-infrared range (880 nm) according to ISO 7027 / EN 27027 records turbidity values under standardized, comparable conditions. A temperature signal is also recorded and transmitted in addition to the turbidity signal. The excitation radiation of an infrared transmitter (→ , item 1) strikes the medium at a defined angle of beam. The different refractions of light between the entrance window and the medium (water) are taken into account. Particles in the medium (item 5) create a scattered radiation which strikes the scattered light receivers (items 3, 4) at a defined angle of beam. The measurement in the medium is constantly compared with the values of a reference receiver (item 2). Digital filter functions with excellent interference signal suppression and sensor self-monitoring ensure additional measurement reliability.

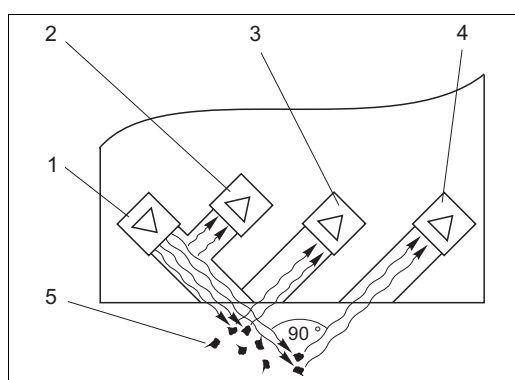

- 1 Infrared sender
- 2 Reference diode
- 3 Scattered light receiver 1
- 4 Scattered light receiver 2
- 5 Particle

Turbidity measurement acc. to ISO 7027 / EN 27027

Measuring system

A complete measuring system comprises:

- Turbidity sensor CUS31
- Transmitter, e.g. Liquisys M CUM253
- Assembly:
 - Flow assembly E or S (each with installed, factory calibrated sensor) or
 - Immersion assembly, e.g. Dipfit W CYA611 or
 - Retractable assembly, e.g. Cleanfit W CUA451

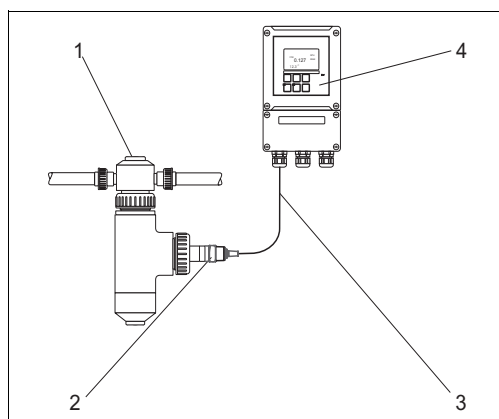

Measuring system with flow assembly

- 1 Flow assembly S
- 2 CUS31-**S
- 3 Sensor cable
- 4 Transmitter Liquisys M CUM253

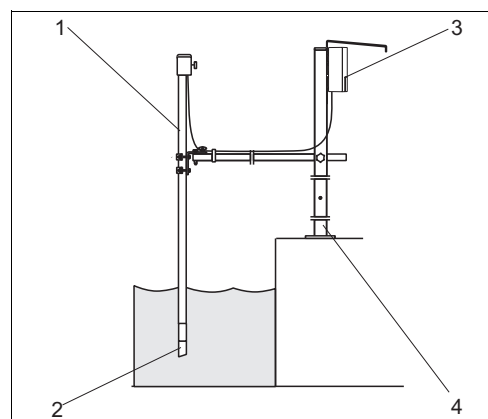

Measuring system with immersion assembly

- 1 Immersion assembly Dipfit W CYA611
- 2 CUS31-**A
- 3 Transmitter Liquisys M CUM253 (with weather protection cover CYY101)
- 4 Universal assembly holder CYH101

Input

Measured variable	Turbidity
Measuring range	0.000 to 9999 FNU 0.00 to 3000 ppm 0.0 to 3.0 g/l 0.0 to 200 %

Power supply

Electrical connection The sensor is connected to the transmitter by means of a multi-core, shielded measuring cable (fixed cable at the sensor). To extend the measuring cable, a VBM or RM junction box and a CYK81 extension cable must be used.

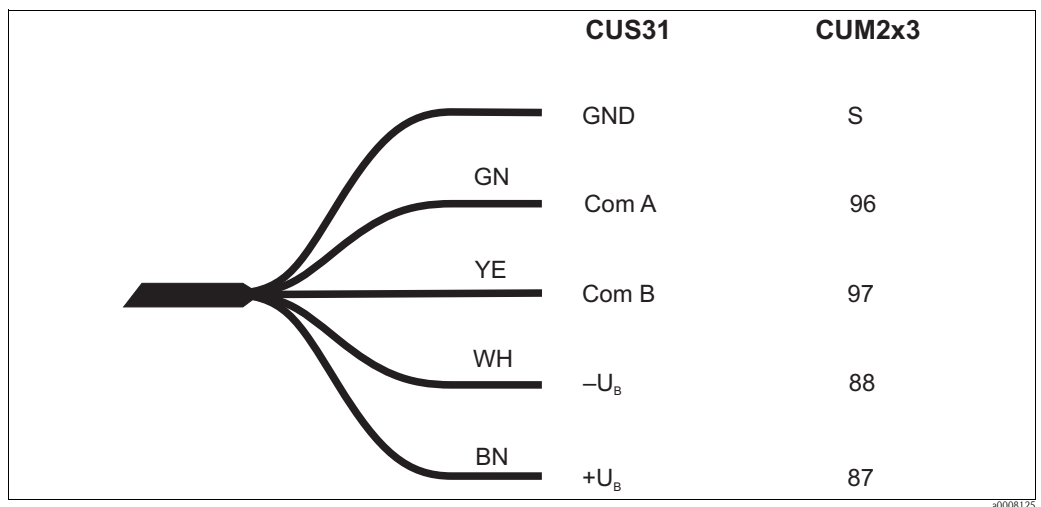

Measuring cable (fixed cable) resp. extension cable (CYK81)



Note! Please pay special attention to the instructions on sensor connection in the Operating Instructions of the transmitter.

Performance characteristics

Maximum measured error	< 5 % (min. 0.02 FNU) of measured value (system measured error related to the primary formazine standard / tracing according to ISO 5725 and ISO 7027 / EN 27027)
Repeatability	< 1 % (min. 0.01 FNU) of measured value
Wavelength	880 nm
Factory calibration	traceable to formazine standard and SiO ₂

Installation

Wall distance

Installing the sensor in pipework or very close to the wall can cause backscatter which results in a higher sensor signal.

The effective wall or bottom distance can be optimized by aligning the flat sensor side.

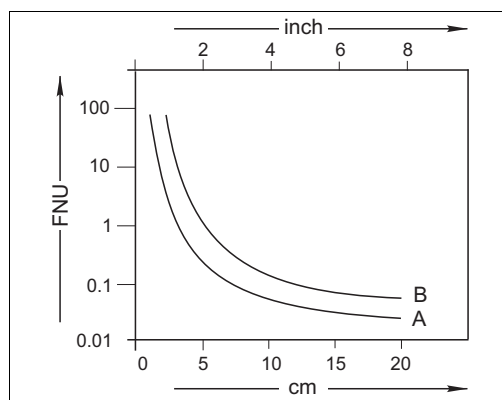

Effect of the distance from the wall or bottom

A Dark wall or bottom (non-reflective)

B Bright wall or bottom (reflective)



Note!

The following generally applies: The lower the turbidity to be measured, the darker the vessel walls should be and the greater the wall distance should also be.

When measuring in drinking water, the wall distance to a dark wall must be **at least 8 cm (3")**. Bright pipes are not suitable for the drinking water sector.

Pipe installation

The following figure illustrates various installation positions in pipes and indicates whether they are permitted or not.

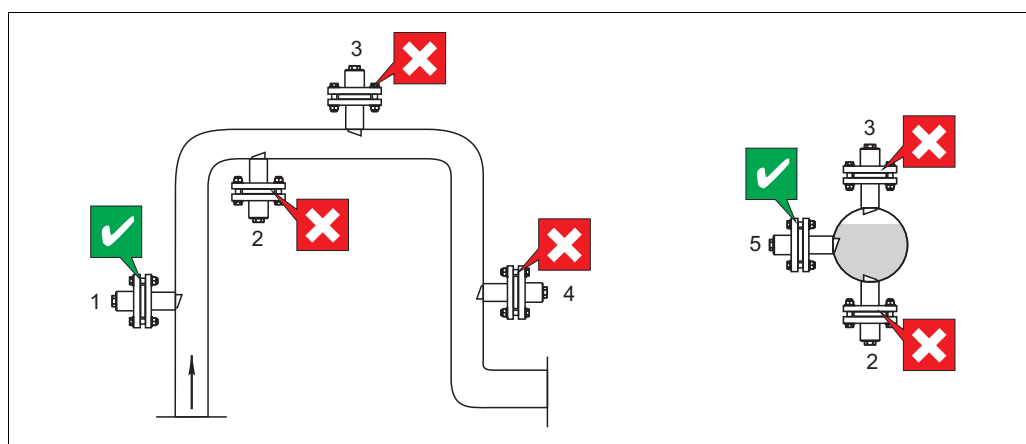

Orientation and installation positions (with adapter CUA120-A/B resp. retractable assembly CUA451)

- The pipeline diameter must be at least 100 mm (4") if reflective materials (e.g. stainless steel) are used.
- Install the sensor in places with uniform flow conditions.
- Orientate the sensor surface against the medium flow (self-cleaning effect).
- The best installation location is in the ascending pipe (→ , it. 1). Installation is also possible in the horizontal pipe (it. 5).
- Do not install the sensor in places where air may collect or foam bubbles form (it. 3) or where suspended particles may settle (it. 2).
- Avoid installation in the down pipe (it. 4).

Flow operation

In general

- Install the flow assembly as vertical as possible so that the medium flows to the sensor from below.
- Two sensor orientations are possible for every installation:
 - Parallel to the medium flow
Orientation parallel to the medium flow is required when using the CUR 3 spray head.
 - Against the medium flow
Orientation against the medium flow is used to increase the self-cleaning effect in heavily-soiled media (> 15 FNU). The wall reflection is negligible here due to the high absorption.

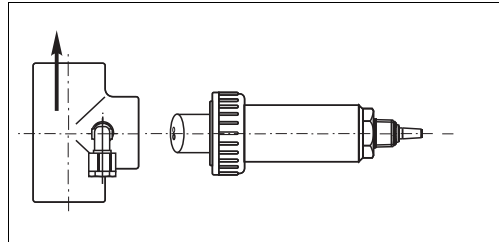

Parallel to the medium flow

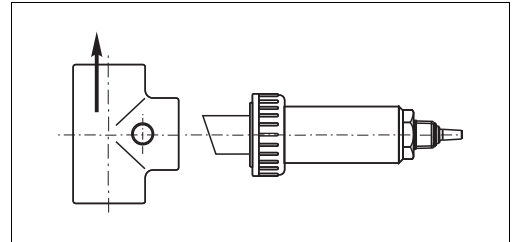

Against the medium flow



Note!

For turbidities < 5 FNU, use the sensor versions CUS31-**E or CUS31-**S.

Flow operation in the drinking water sector (with special calibration)

When the sensor is ordered with assembly E or S, the sensor is **individually calibrated** in the factory with the assembly ordered.

Therefore, no initial calibration on site is necessary.

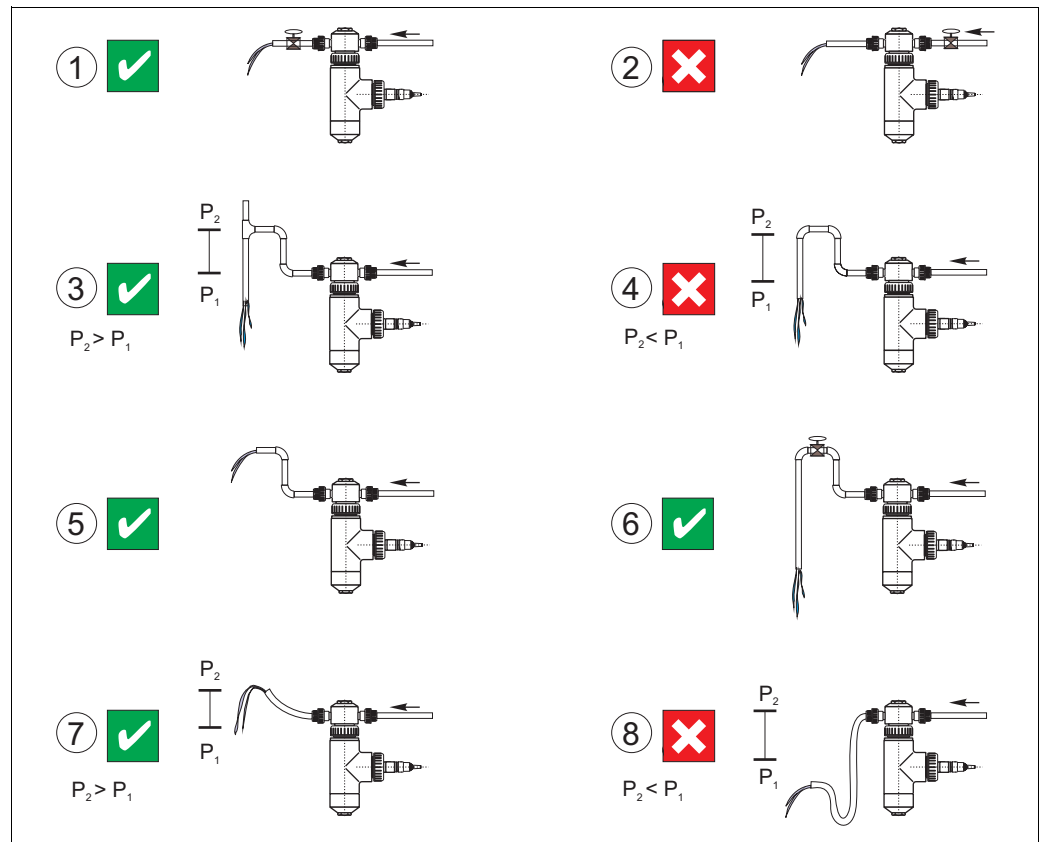

Installation situations with flow assembly E resp. S

1. Correct: pressure reduction after measurement
Degassing is avoided. The gas in the water remains dissolved.
2. Incorrect: Pressure reduction before measurement
The pressure reduction creates favourable conditions for gas bubble formation.

3. Correct: Outlet of the assembly raised and vented
Gas cannot collect in the upper section of the assembly. The outlet pipe is vented at the highest point. A slight overpressure forms in the assembly as a result of the height difference of the raised outlet.
4. Incorrect: Outlet raised but not vented
A low pressure forms in the assembly if venting via the downcomer outlet pipe does not take place due to too small a cross-section.
5. Correct: Standard application in event of little initial pressure
Slight overpressure due to raised outlet level, no gas collecting in the upper section of the assembly.
6. Limited application: The valve reduces the volume flow

 **Note!**
The outlet line may not be too thin or too long as otherwise a low pressure forms in the assembly. A vent for the drain line must be present. The outlet must be completely opened at regular intervals as otherwise the raising of the outlet level would not make any sense.
If using a tube as the drain line, avoid formation of siphon draw (low points in the tube)! Otherwise venting does not take place.
7. Correct: Tube as outlet line
Must be raised!
8. Incorrect: Tube not raised
A low pressure forms in the assembly which favours gas bubble formation. In addition, low points in the tube result in siphon draw and thereby prevent venting. This results in pressure changes in the assembly.

Gas bubble elimination

Conventional turbidity measurements are carried out in an unpressurised sample. When the pressure on a sample (which was pressurised beforehand) is released, fine bubbles are produced which distort the turbidity measurement.

There are several methods of eliminating these gas bubbles:

- Pressurized measurement in the bypass (pressure is not released until after the measurement).
- For measurements without overpressure or with slight overpressure:
Free medium flow above the assembly level. The mounting location should be as low as possible to take advantage of the maximum possible pressure.
- Unpressurized measurement and gas bubble elimination using wiper cleaning.
The wiping duration and interval can be programmed for optimum results.
- Reduction of the flow to the lowest possible value (50 l/h).
Slight flow prolongs the period in which the medium is in the assembly. This means that gas bubbles have more time to rise to the top. The sensor response time increases slightly due to the lower flow.
- Flow assembly S with integrated gas bubble trap (CUS31-***S)
Most of the gas bubbles are sent directly to the assembly outlet in the upper half of the separated inlet (7). The other half of the medium flows into a ring channel (1) by means of the central pipe. The remaining bubbles rise here and are conveyed out of the measuring chamber by means of holes in the outlet (2) located in the centre of the assembly. Bubble-free medium (3) is pushed down into the measuring chamber (5). This also leads to a high flow which results in a quick response time. In addition, this almost completely prevents dirt particles settling.

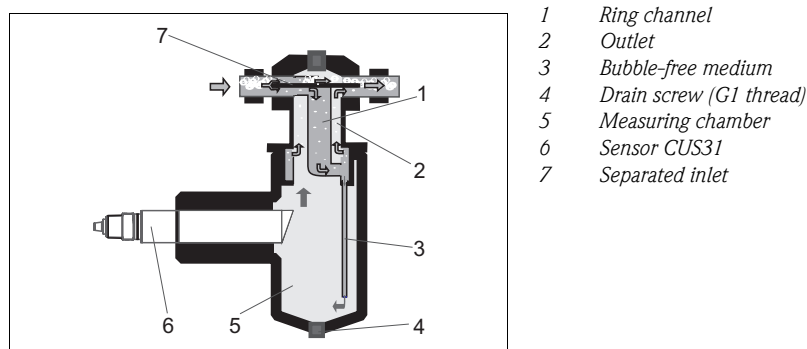

Flow assembly S with gas bubble trap

a0008442

Immersion operation

When installing the sensor in immersion assemblies, please ensure that a sufficient wall distance is observed during operation.

- For this reason, select an installation location in which **a minimum wall distance of 150 mm (6")** is observed even with varying levels or altered flow profiles.
Mounting in a suspended assembly with chain must therefore be avoided.
- The sensor must immerse at least 40 mm (1.5") into the medium.

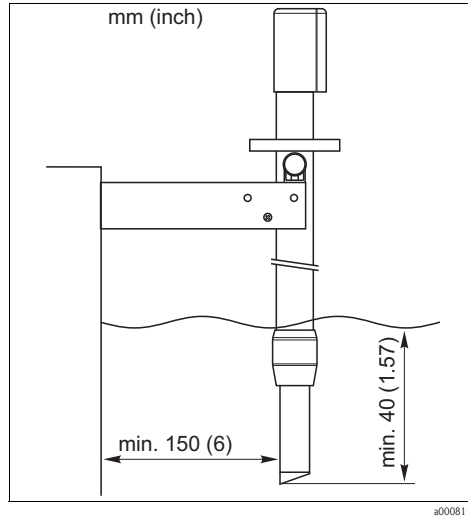

CYA611 with pendulum frame

Environment

Storage temperature	-20 to 60 °C (0 to 140 °F)
Ingress protection	IP 68

Mechanical construction

Dimensions

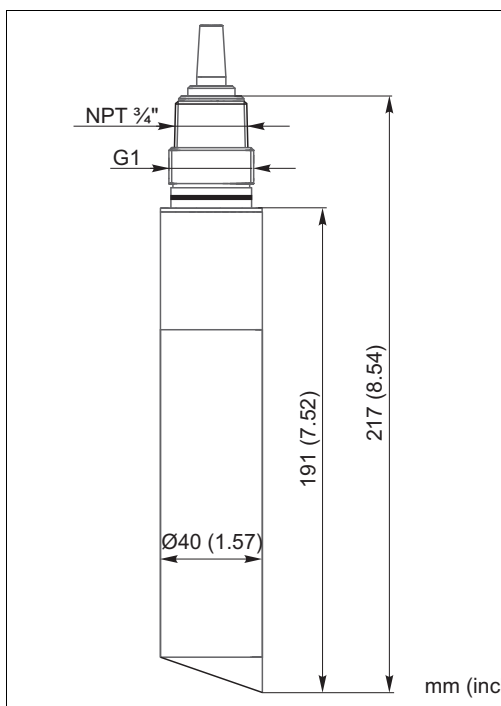

CUS31

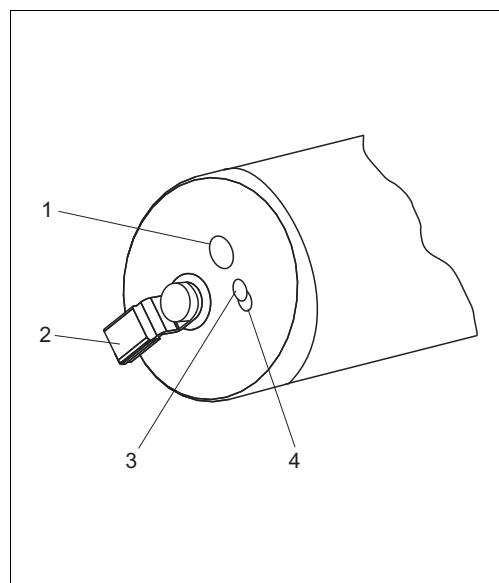

Sensor optics

- 1 Photodiode (receiver)
- 2 Wiper (optional)
- 3 Photodiode (receiver)
- 4 LED (IR transmitter)

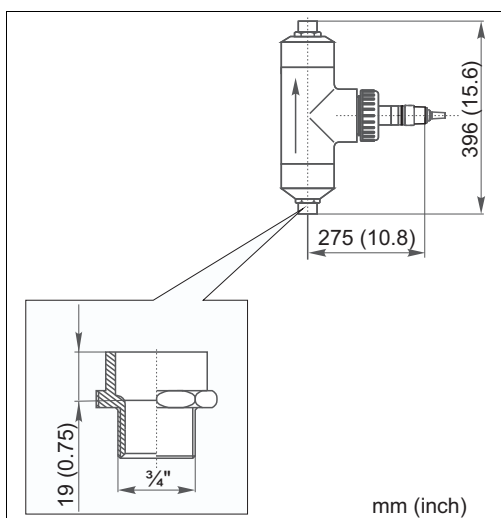

CUS31-**E (with assembly E)

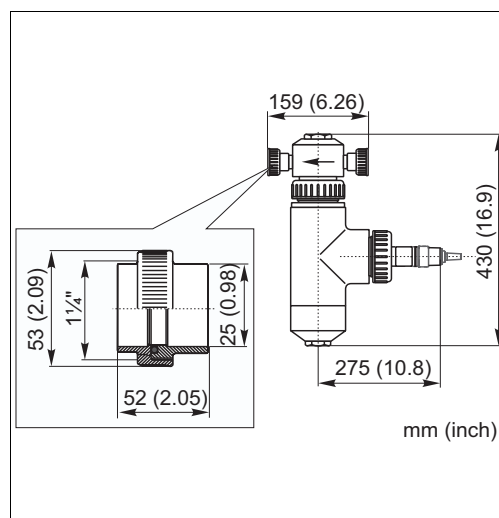

CUS31-**S (with assembly S)

Weight with cable length 7 m (23 ft): 0.7 kg (1.5 lbs.)
with cable length 15 m (49 ft): 1.1 kg (2.4 lbs.)

Material Sensor carrier plate, shaft PVC / PPS GF 40 (polyphenylene sulfide with 40% glass-fibre)
Optical windows Sapphire
Flow assemblies E and S PE
Wiper (CUS31-W** only) Rubber
Cable TPEO (polyolefine based elastomer), -40 to 130 °C (-40 to 260 °F)

Process connection G1 and NPT 3/4"

Temperature sensor NTC resistor 30K at 25 °C (77 °F)

Ordering information

Product structure

Sensor	
A	Standard sensor
W	Sensor with integr. wiper
Cable length	
2	Connecting cable 7 m (23 ft)
4	Connecting cable 15 m (49 ft)
9	Special cable length
Assembly	
A	Without assembly
E	Assembly for bubblefree media
S	Assembly with integr. debubbling system
CUS31-	complete order code

Scope of delivery

The scope of delivery comprises:

- Turbidity sensor acc. to the version:
 - CUS31-**A
factory-calibrated sensor, without assembly
 - CUS31-**E
installed and factory-calibrated in assembly for bubble-free media, with fixing bracket
 - CUS31-**S
installed and factory-calibrated in assembly with gas bubble trap, with fixing bracket
- Operating Instructions BA176C/07/en

Certificates, approvals

Quality certificate

Each sensor has an individual quality certificate with information on the sensor identification and calibration according to ISO 7027 / EN 27027.

Accessories

Connection accessories

CYK81 measuring cable

- Non-terminated measuring cable for extension of sensor cables of e.g. Memosens sensors, CUS31/CUS41
- 2 wires, twisted pair with shield and PVC-sheath (2 x 2 x 0.5 mm² + shield)
- Sold by the meter, order no. 51502543

Junction box VBM

- For cable extension
- 10 terminals
- Cable entries: 2 x Pg 13.5 or 2 x NPT ½"
- Material: aluminum
- Ingress protection: IP 65 (≅ NEMA 4X)
- Order numbers:
 - cable entries Pg 13.5: 50003987
 - cable entries NPT ½": 51500177

Junction box RM

- For cable extension (e.g. for Memosens sensors or CUS31/CUS41)
- 5 terminals
- Cable entries: 2 x Pg 13.5
- Material: PC
- Ingress protection: IP 65 (≅ NEMA 4X)
- Order no.: 51500832

Installation accessories

Immersion assembly holder CYH101

- For pH, ORP, oxygen, conductivity assemblies and for oxygen and turbidity sensors;
- Ordering acc. to product structure (Technical Information TI092C/07/en)

Immersion assembly Dipfit W CYA611

- For sensor immersion in basins, open channels and tanks, PVC
- Ordering acc. to product structure, see Technical Information TI166C/07/en

Flange adapter CUA120

- for CUS31/CUS41
- Ordering information:
 - CUA120-A for welding flange, h=47 mm (1.85")
 - CUA120-B for welding flange, h=93 mm (3.66")

Flow assembly Flowfit CUA250

- for CUS31/CUS41
- ordering acc. to product structure (Technical Information TI096C/07/en)

Retractable assembly Cleanfit CUA451

- retractable assembly with ball valve; for turbidity sensors; material: stainless steel
- ordering acc. to product structure (Technical Information TI369C/07/en)

Welding rinse socket DN 65

- order no. 51500912

Welding rinse socket DN 50 / PN 16

- order no. 55001306

Transmitter

Liquisys M CUM 223/253

- Turbidity transmitter
- Panel mounting or field housing
- Optional with Hart® or Profibus communication
- Ordering acc. to product structure, see Technical Information TI200C/07/en

Cleaning

Chemoclean

- Injector CYR10 and program sequencer CYR20
- Ordering acc. to product structure, see Technical Information (TI046C/07/en)

Chemoclean CUR3

- Spray head for flow assemblies CUA250 and COA250
- order no. CUR3-1

Monitoring, service kit, recalibration

CUY22

- Check unit for CUS31 for checking the sensor
- order no. 51504477

Service kit CUY31

- 3 spare wiper arms
- order no. 50089252

Recalibration CUS31

- Calibration as per ISO 7027 / EN 27027
- order no. 50081264

Instruments International

Endress+Hauser
Instruments International AG
Kaegenstrasse 2
4153 Reinach
Switzerland

Tel.+41 61 715 81 00
Fax+41 61 715 25 00
www.endress.com
info@ii.endress.com

Endress+Hauser 
People for Process Automation