



GA24 Technical Datasheet

Variable-area flowmeter

- Sturdy construction for several applications
- Local indication without auxiliary power
- Replaceable mounting parts



| | | |
|-------|------------------------------|----|
| 1 | Product features | 3 |
| 1.1 | GA24 Variable area flowmeter | 3 |
| 1.2 | Operating principle | 4 |
| 2 | Technical data | 5 |
| 2.1 | Technical data | 5 |
| 2.2 | Dimensions and weights | 8 |
| 2.3 | Measuring ranges | 9 |
| 3 | Installation | 11 |
| 3.1 | Intended use | 11 |
| 3.2 | Installation conditions | 11 |
| 4 | Electrical connections | 12 |
| 4.1 | Limit switches GA24 | 12 |
| 4.1.1 | MS14 limit switch connection | 13 |
| 4.1.2 | TG21 limit switch connection | 13 |
| 5 | Order form | 14 |
| 6 | Notes | 15 |

1.1 GA24 Variable area flowmeter

The GA24 flowmeter is designed for measuring the volume or mass flow rate of liquids and gases and for measuring gases at low operating pressures.



Highlights

- Universal installation length concept
- Low pressure loss in gas applications
- Low maintenance
- Optional limit switch
- Quick and easy to install and operate
- Easy feeding of suspended solid particle (can also be installed at a later date)
- Fragment protection

Industries

Can be used in all industrial sectors, for example

- Chemicals
- Heating, Ventilation & Air Conditioning (HVAC)
- Iron, Steel & Metals
- Oil and Gas
- Power plants
- Machinery
- Paper and Pulp
- Water
- Furnace construction

Applications

- Gas measurements
- Industrial burner controlling
- Compressor monitoring
- Water circuits

1.2 Operating principle

The flowmeter operates on the float measuring principle

The measuring unit consists of a glass cone in which a float can move freely up and down.

The flow goes from bottom to top.

The float changes position so that the lifting force acting on it F_1 is in equilibrium with the form drag F_2 and its weight F_3 : $F_3 = F_1 + F_2$

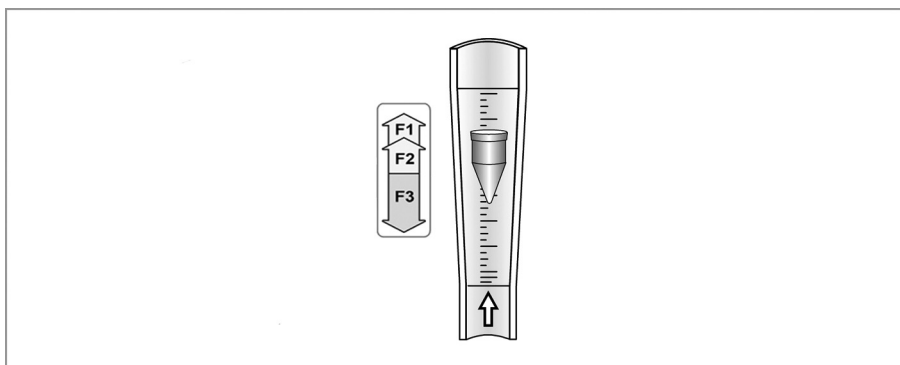

The height of the float is read on the scale of the measuring glass and indicates the flow rate.

The top edge of the float marks the reading line for flow values.

2.1 Technical data

- *The following data is provided for general applications. If you require data that is more relevant to your specific application, please contact us or your local representative.*
- *Additional information (certificates, special tools, software,...) and complete product documentation can be downloaded free of charge from the website (Download Center).*

Measuring system

| | |
|--|---|
| Application range | Flow measurement of liquids, gases and vapors |
| Operating method / measuring principle | Variable area measuring principle |
| Measured value | |
| Primary measured value | Float position |
| Secondary measured value | Operating and standard volumetric flow |
| Measuring accuracy | |
| Directive | VDI / VDE 3513, sheet 2 (q _G =50%) |
| Measuring accuracy | 1.0% |

Operating conditions

| | |
|--|---|
| Temperature | |
| Max. operating temperature TS | -40...+120°C / -40...+248°F |
| Pressure | |
| Max. permitted operating gauge pressure PS at TS = 100°C | Pressure equipment directive 97/23/EC |
| Test pressure PT | Pressure equipment directive 97/23/EC or AD 2000-HP30 |
| DN15, DN25 | 10 bar ① |
| DN40 | 9 bar ① |
| DN50 | 7 bar ① |

Installation conditions

| | |
|-----------------------|----------|
| Inlet condition, run | ≥ 5 x DN |
| Outlet condition, run | ≥ 3 x DN |

① other pressures upon request

Materials

| | |
|-------------------------------------|--|
| Flange connection GA24/R | Stainless steel 1.4404 (316 L) |
| Flange connection GA24/PTFE | Stainless steel 1.14404 (316 L) with a liner made of PTFE |
| Housing | Steel plate housing (zinc-plated with epoxy/polyester coating) |
| Measuring cone | Borosilicate glass |
| Suspended solid particle | Stainless steel 1.4571 (316 Ti) or Hastelloy C2000 |
| | PTFE/insert or TFM (PTFE) |
| | Aluminum |
| | Polypropylen (PP) |
| Suspended solid particle and insert | PVDF (conforms to FDA) |
| Seals | Neoprene |
| | PTFE Scherring |
| | PTFE sleeve |

Temperatures

For devices to be used in hazardous areas, special temperature ranges apply. These can be found in the separate instructions.

| | | |
|-------------------------------------|----------------|--------------|
| Max. measuring temperature T_m | -40...+120°C ① | -40...+248°F |
| Max. ambient temperature $T_{amb.}$ | -20...+100°C | -4...+212°F |

① higher temperatures on request

Types of limit switches

| Type | Switching function | Connection | Shape | Note |
|---------|--------------------|------------------|--------------------------|----------------------------|
| MS 14/A | bistable | 2-wire, floating | Reed contact | Float with magnet required |
| TG 21 | bistable | 2-wire NAMUR | Slotted proximity switch | Float with magnet required |

Limit switch use

| Size | Cone no. | Limit switch | Size | Cone no. | Limit switch |
|------|----------|--------------|------|----------|--------------|
| DN15 | N 18.07 | MS14/A | DN25 | N 21.09 | MS14/A TG21 |
| | N 18.09 | MS14/A | | N 21.13 | MS14/A TG21 |
| | N 18.13 | MS14/A | | N 21.18 | MS14/A TG21 |
| | N 19.09 | MS14/A | | N 21.25 | MS14/A TG21 |
| | N 19.13 | MS14/A | DN40 | N 41.09 | MS14/A TG21 |
| | N 19.19 | MS14/A | | N 41.13 | MS14/A TG21 |
| | N 19.26 | MS14/A | | N 41.19 | MS14/A TG21 |
| | | | DN50 | N 51.10 | MS14/A TG21 |
| | | | | N 51.15 | MS14/A TG21 |
| | | | | N 51.21 | MS14/A TG21 |

Technical Data Limit Switches

Technical data MS14

| | |
|--|--|
| Contact type | Normally open or normally closed, can be reconnected |
| Switching reproducibility | < 2% of full-scale range |
| Contact rating | 12VA |
| max. turn-on voltage | 30VDC |
| Max. switching current | 0,5A |
| Ambient temperature | -20...+85°C / -4...+185 °F |
| Protection category acc. to IEC 60529 / EN 529 | IP44 |

Technical data TG21

| | |
|--|------------------------------|
| Rated voltage | 8VDC |
| Current consumption, active surface open | 3mA |
| Current consumption, active surface covered | 1mA |
| Ambient temperature | -25...+100°C / -13...+212 °F |
| Protection category acc. to IEC 60529 / EN 529 | IP 67 (NEMA 6) |

2.2 Dimensions and weights

Dimensions

| Nominal size | | a | | b | | c | | d | |
|--------------|--------|-----|------|-----|------|-----|------|-----|------|
| DN | Inch | mm | Inch | mm | Inch | mm | Inch | mm | Inch |
| 15 | 1/2" | 500 | 19.7 | 300 | 11.8 | 84 | 3.31 | 82 | 3.23 |
| 25 | 1" | 500 | 19.7 | 300 | 11.8 | 105 | 4.13 | 102 | 4.02 |
| 40 | 1 1/2" | 500 | 19.7 | 300 | 11.8 | 125 | 4.92 | 122 | 4.80 |
| 50 | 2" | 500 | 19.7 | 300 | 11.8 | 165 | 6.50 | 147 | 5.74 |

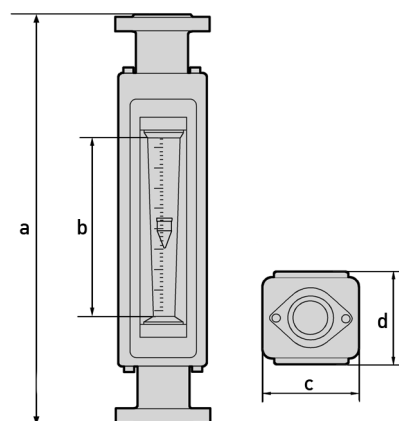

Weights

| | approx. kg | approx. lb |
|------|------------|------------|
| DN15 | 6 | 13 |
| DN25 | 10 | 22 |
| DN40 | 13 | 29 |
| DN50 | 18 | 40 |

Process connection

| | Connection dimensions according to | Connection | Pressure class |
|---------------------|------------------------------------|------------|-------------------|
| Flanged connections | EN 1092 | DN15, DN25 | PN25 |
| | EN 1092 | DN40 DN50 | PN10 |
| | ASME B16.5 | 1/2"...2" | Class 150 lb / RF |
| | ASME B16.5 | 1/2"...2" | Class 300 lb / RF |

2.3 Measuring ranges

| | |
|-----------------------|--|
| Measuring span 10 : 1 | Flow values 100% |
| Reference condition: | Water 20°C / Air 20°C - 1.013 bar abs. |
| Float materials: | 1 Stainless Steel or Hastelloy® - 2 PTFE - 3 TFM - 4 Aluminium - 5 Polypropylen (PP) |

| Materials → | | 1 | 2 | 3 | 1 | 3 | 4 | 5 | 1 | 2 | 3 | 4 | 5 |
|-------------|------|------------------|------|------|------------------------------|------|-------|-------|---------------------------|----|----|----|----|
| Cone ↓ | | Flow water [l/h] | | | Flow air [m ³ /h] | | | | Max. pressure loss [mbar] | | | | |
| N 18.07 | DN15 | 40 | 25 | 13 | 1.5 | 0.6 | 0.8 | 0.5 | 9 | 6 | 2 | 3 | 1 |
| N 18.09 | | 63 | 40 | 22 | 2.2 | 0.95 | 1.2 | 0.7 | 9 | 7 | 3 | 3 | 2 |
| N 18.13 | | 100 | 63 | 35 | 3 | 1.5 | 1.8 | 1.2 | 9 | 8 | 3 | 4 | 2 |
| N 19.09 | | 160 | 100 | 55 | 5 | 2.2 | 2.8 | 1.8 | 13 | 9 | 4 | 5 | 2 |
| N 19.13 | | 250 | 160 | 85 | 8 | 3.3 | 4.5 | 2.8 | 16 | 11 | 4 | 5 | 2 |
| N 19.19 | | 400 | 250 | 140 | - | - | - | - | 21 | 14 | 5 | - | - |
| N 19.26 | | 630 | 400 | 230 | - | - | - | - | 27 | 17 | 6 | - | - |
| N 21.09 | DN25 | 630 | 400 | 230 | 18 ① | 9 | 11 | 7 | 22 | 14 | 6 | 8 | 3 |
| N 21.13 | | 1000 | 630 | 350 | 28 ① | 14 | 18 | 12 | 23 | 17 | 6 | 8 | 4 |
| N 21.18 | | 1600 | 1000 | 600 | 49 ① | - | 28 ① | 17 ① | 26 | 25 | 7 | 10 | 6 |
| N 21.25 | | 2500 | 1600 | 950 | 70 ① | - | 42 ① | 26 ① | 33 | 40 | 8 | 12 | 9 |
| N 41.09 | DN40 | 1600 | 1000 | 600 | 45 ① | 22 | 28 | 18 | 32 | 18 | 9 | 11 | 5 |
| N 41.13 | | 2500 | 1600 | 900 | 70 ① | 36 | 45 ① | 28 ① | 34 | 20 | 10 | 12 | 5 |
| N 41.19 | | 4000 | 2500 | 1500 | 128 ① | - | 76 ① | 46 ① | 38 | 24 | 11 | 15 | 8 |
| N 51.10 | DN50 | 4000 | 2500 | 1500 | 120 ① | 56 | 70 | 45 | 43 | 25 | 12 | 15 | 7 |
| N 51.15 | | 6300 | 4000 | 2400 | 190 ① | 90 | 110 ① | 70 ① | 47 | 30 | 13 | 16 | 7 |
| N 51.21 | | 10000 | 6300 | 3500 | 310 ① | - | 170 ① | 118 ① | 55 | 42 | 14 | 20 | 10 |

① only possible with guided float

The operating pressure should be at least double the pressure loss for liquids and five times for gases. The indicated pressure losses are valid for water and air at maximum flow rate. Conversion to other products or operating data is performed by KROHNE using the calculation method stipulated by VDI/VDE Directive 3513.

| | |
|-----------------------|--|
| Measuring span 10 : 1 | Flow values 100% |
| Reference condition: | Water 68°F / Air 68°F - 14.7 psi |
| Float materials: | 1 Stainless Steel or Hastelloy® - 2 PTFE - 3 TFM - 4 Aluminium - 5 Polypropylen (PP) |

| Materials → | | 1 | 2 | 3 | 1 | 3 | 4 | 5 | 1 | 2 | 3 | 4 | 5 |
|-------------|------|-------------------|------|------|------------------|------|-------|--------|--------------------------|------|------|------|------|
| Cone ↓ | | Flow, water [gph] | | | Flow, air [scfm] | | | | Max. pressure loss [psi] | | | | |
| N 18.07 | DN15 | 10.6 | 6.6 | 3.43 | 0.93 | 0.37 | 0.5 | 0.31 | 0.1 | 0.1 | 0.03 | 0.04 | 0.02 |
| N 18.09 | | 16.6 | 10.6 | 5.81 | 1.36 | 0.59 | 1.2 | 0.43 | 0.1 | 0.1 | 0.04 | 0.04 | 0.03 |
| N 18.13 | | 26.4 | 16.6 | 9.25 | 1.86 | 0.93 | 0.74 | 0.74 | 0.1 | 0.1 | 0.04 | 0.06 | 0.03 |
| N 19.09 | | 42.3 | 26.4 | 14.5 | 3.1 | 1.36 | 1.7 | 1.1 | 0.19 | 0.13 | 0.06 | 0.07 | 0.03 |
| N 19.13 | | 66.0 | 42.3 | 22.5 | 4.96 | 2.05 | 2.8 | 1.7 | 0.2 | 0.16 | 0.06 | 0.07 | 0.03 |
| N 19.19 | | 105 | 66.0 | 37 | - | - | - | - | 0.3 | 0.2 | 0.07 | - | - |
| N 19.26 | | 166 | 106 | 60.8 | - | - | - | - | 0.4 | 0.25 | 0.09 | - | - |
| N 21.09 | DN25 | 166 | 106 | 60.8 | 11.2 ① | 5.58 | 6.8 | 4.3 | 0.3 | 0.2 | 0.09 | 0.1 | 0.06 |
| N 21.13 | | 264 | 166 | 92.5 | 17.4 ① | 8.68 | 11 | 7.4 | 0.3 | 0.25 | 0.09 | 0.1 | 0.06 |
| N 21.18 | | 423 | 264 | 158 | 30.4 ① | - | 17 ① | 10.5 ① | 0.3 | 0.3 | 0.1 | 0.15 | 0.9 |
| N 21.25 | | 660 | 423 | 251 | 43.4 ① | - | 26 ① | 16 ① | 0.48 | 0.58 | 0.1 | 0.17 | 0.13 |
| N 41.09 | DN40 | 423 | 264 | 158 | 27.9 ① | 13.6 | 17 | 11 | 0.48 | 0.26 | 0.1 | 0.16 | 0.07 |
| N 41.13 | | 660 | 423 | 238 | 43.4 ① | 22.3 | 28 ① | 17.4 ① | 0.49 | 0.29 | 0.15 | 0.17 | 0.07 |
| N 41.19 | | 1057 | 660 | 396 | 79.4 ① | - | 47 ① | 28.5 ① | 0.55 | 0.35 | 0.16 | 0.22 | 0.1 |
| N 51.10 | DN50 | 1057 | 660 | 396 | 74.4 ① | 34.7 | 43.4 | 27.9 | 0.62 | 0.36 | 0.17 | 0.22 | 0.1 |
| N 51.15 | | 1664 | 1057 | 634 | 118 ① | 55.8 | 68 ① | 43.4 ① | 0.68 | 0.44 | 0.19 | 0.23 | 0.1 |
| N 51.21 | | 2642 | 1664 | 925 | 192 ① | - | 105 ① | 73 ① | 0.8 | 0.61 | 0.2 | 0.29 | 0.15 |

① only possible with guided float

The operating pressure should be at least double the pressure loss for liquids and five times for gases. The specified pressure losses are valid for water and air at maximum flow rate. Conversion to other products or operating data is performed by KROHNE using the calculation method stipulated in VDI/VDE Directive 3513.

3.1 Intended use

The variable area flowmeters are suitable for measuring gases and liquids.

The devices are particularly suitable for the measurement of:

- Liquids
- Hydrocarbons
- Water
- Chemicals with low corrosiveness
- Industrial gases

For devices used in hazardous areas, additional safety notes apply; please refer to the Ex documentation.

Responsibility for the use of the measurement devices with regard to suitability, intended use and corrosion resistance of the used materials against the measured fluid lies solely with the operator.

The manufacturer is not liable for any damage resulting from improper use or use for other than the intended purpose.

Do not use any abrasive or highly viscous media.

3.2 Installation conditions

When installing the device in the piping, the following points must be observed:

- *The variable area flowmeter must be installed vertically (measuring principle). Flow direction from bottom to top. For installation recommendations please refer also to VDI/VDE 3513 Sheet 3.*
- *Before connecting, blow or flush out the pipes leading to the device.*
- *Pipes for gas flow need to be dried before the device is installed.*
- *Use connectors suitable for the particular device version.*
- *Align the pipes centrically with the connection bores on the measuring device so they are free of stresses.*
- *If necessary, support the pipeline to reduce vibrations being transmitted to the measuring device.*
- *Do not lay signal cables directly next to cables for the power supply.*

4.1 Limit switches GA24

The flowmeters GA24 can be equipped with a maximum of two bistable limit switches.

Bistable function: Stable switching when passing through the switching point

Use, selection and function - see Technical Data

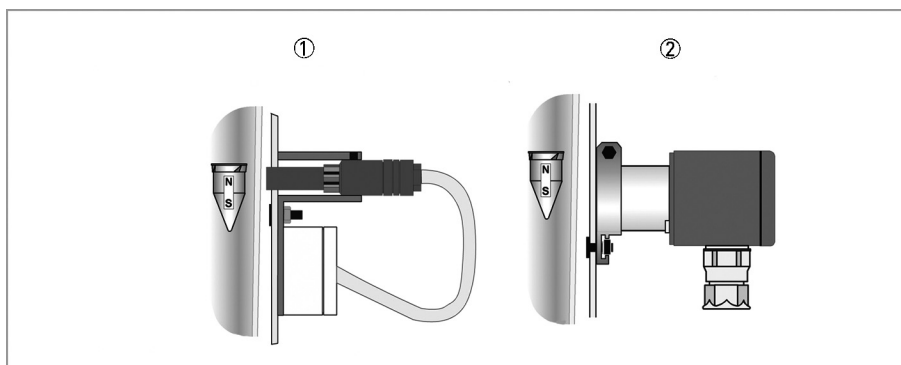

Figure 4-1: Types of limit switch

- ① MS 14/1 - floating, bistable reed contact
- ② TG21 - bistable, with integrated switching lug and slotted proximity switch

4.1.1 MS14 limit switch connection

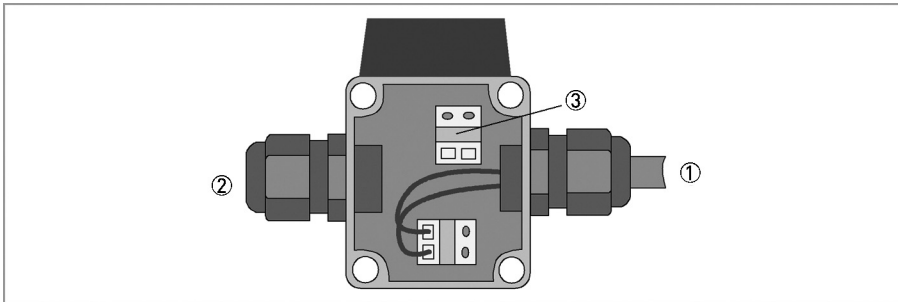

Figure 4-2: Connection limit switch type MS14

- ① Connection Reed-switch
- ② Connection Receiver device
- ③ Terminal connection (potential-free)

The switching function requires a float with integrated magnet.

4.1.2 TG21 limit switch connection

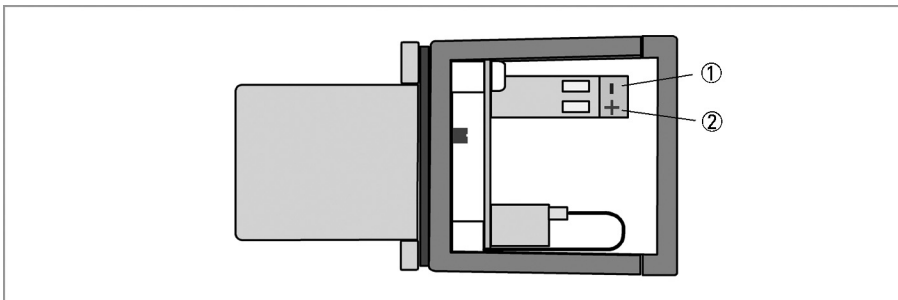

Figure 4-3: Connection limit switch type TG21

- ① Terminal -
- ② Terminal +

The TG 21 is adapted for switch amplifiers with an intrinsically safe circuit as per DIN EN 50227 NAMUR.

The TG 21 includes an inductive slotted proximity switch with bistable switching characteristics. The slotted proximity switch is activated by the immersion of an aluminum lug. The magnet of the immersion lug is moved by the magnet in the float. The switching function requires a float with integrated magnet.

Please provide us with the missing information so that we can be of help to you as quickly as possible.

Then please fax this page to the appropriate sales associate. We will then contact you as soon as possible.

Device data

| | | |
|------------------|--|-------------------------------------|
| Connection type: | <input type="checkbox"/> EN 1092 | <input type="checkbox"/> ASME B16.5 |
| Pressure rating: | | |
| Limit switch: | <input type="checkbox"/> K1 ① <input type="checkbox"/> K2 ② | |
| Approval: | <input type="checkbox"/> Disable | <input type="checkbox"/> ATEX |

① 1 limit switch

② 2 limit switches

Rating data

| | | | |
|------------------------|--|--|--|
| Product: | | | |
| Operating pressure: | | <input type="checkbox"/> Absolute pressure | <input type="checkbox"/> Overpressure |
| Rated pressure: | | | |
| Operating temperature: | | | |
| Rated temperature: | | | |
| Density: | | <input type="checkbox"/> Standard density | <input type="checkbox"/> Operating density |
| Viscosity: | | | |
| Measuring range: | | | |
| Comments: | | | |

Contact data

| | |
|-------------------|--|
| Company: | |
| Contact person: | |
| Telephone number: | |
| Fax number: | |
| E-mail: | |



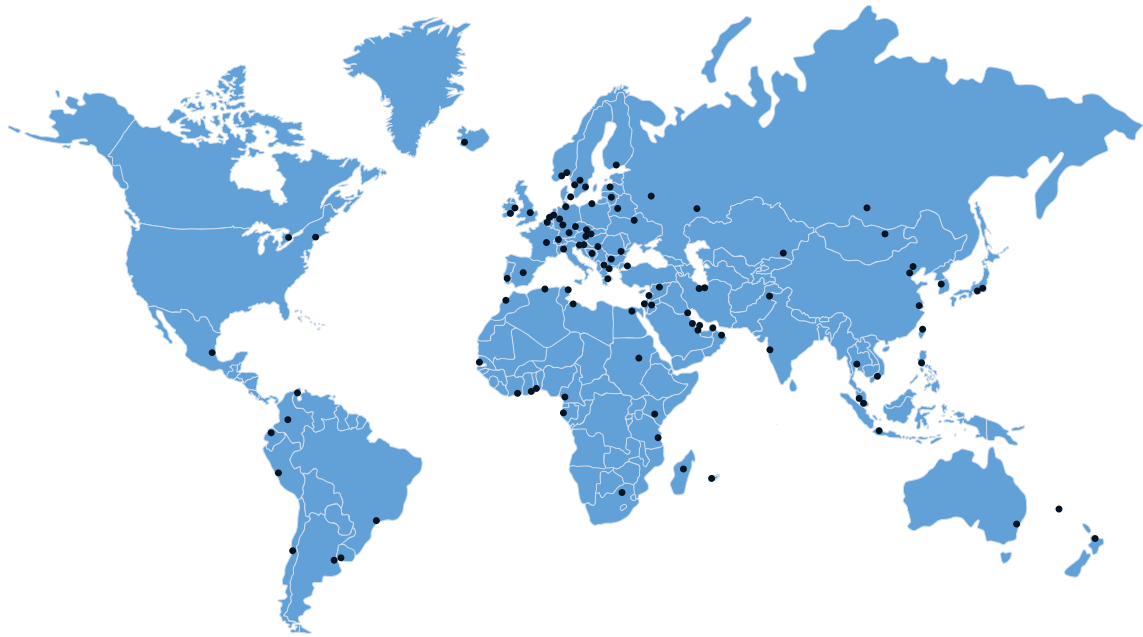

KROHNE product overview

- Electromagnetic flowmeters
- Variable area flowmeters
- Ultrasonic flowmeters
- Mass flowmeters
- Vortex flowmeters
- Flow controllers
- Level meters
- Temperature meters
- Pressure meters
- Analysis products
- Measuring systems for the oil and gas industry
- Measuring systems for sea-going tankers

Head Office KROHNE Messtechnik GmbH
Ludwig-Krohne-Str. 5
D-47058 Duisburg (Germany)
Tel.:+49 (0)203 301 0
Fax:+49 (0)203 301 10389
info@krohne.de

The current list of all KROHNE contacts and addresses can be found at:
www.krohne.com

KROHNE