



[www.hy-lok.com](http://www.hy-lok.com)

Catalog No. H-100PIV  
Feb. 2019



# Double Block & Bleed Valves

---



**HY-LOK CORPORATION**

© 2003, 2006, 2019 HY-LOK CORPORATION All rights reserved



**INTRODUCTION** ----- 3

**APPLICATION & INSTALLATION** ----- 4

**SPECIFICATION** ----- 5 - 9

General  
 Ball valve  
 OS & Y needle type globe valve  
 Needle type globe valve  
 Material of construction

**MODULAR VALVES** ----- 10 - 15

Product Range / Dimensions & Weights

**MONOFLANGE VALVES** ----- 16 - 19

Product Range / Dimensions & Weights

**ROOT VALVES** ----- 20 - 22

Product Range / Dimensions & Weights

**ORDERING INFORMATION** ----- 23

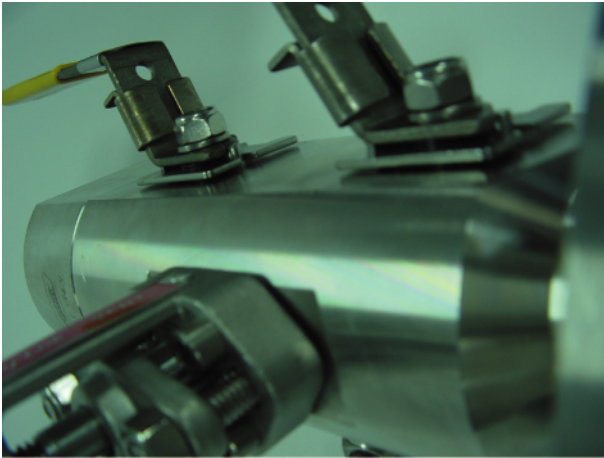

Hy-Lok Integral Block & Bleed Valves have been specifically designed to provide a compact installation for gauge or transmitter instruments.

Used as an alternative to multivalve systems the advantages of reduced weight and minimum leakpaths provide for a higher integrity system. And the reduced height of the installation reduces the risk of damage through vibration as well.

Hy-Lok Integral Block & Bleed Valves is a leader in its field. A company that has built its reputation on inspired development, precision engineering and high quality customer service satisfies the demands of industry worldwide.

Today, Hy-Lok Integral Block & Bleed Valves is uniquely placed to offer an unrivalled range of standard products from stock, together with a supreme manufacturing capability to handle specific requirements and exotic materials. In addition, the company has the technical ability and resources to develop bespoke products for the most demanding or unusual applications.



A team of dedicated engineering specialists brought together to solve problems and deliver high quality solutions worldwide.



Consistently high levels of performance in design, manufacturing, inventory management, quality, system development and service.



Design excellence, drawing on engineering expertise from project experience the world over. Meeting the most demanding applications.



CONVENTIONAL ASSEMBLY

Hy-Lok Integral Block & Bleed Valve ASSEMBLY

Hy-Lok Instrumentation Products has the ultimate solutions for a compact range of one-piece forged body Integral block & bleed valves, featuring a choice of end connections, body styles and valve technology.

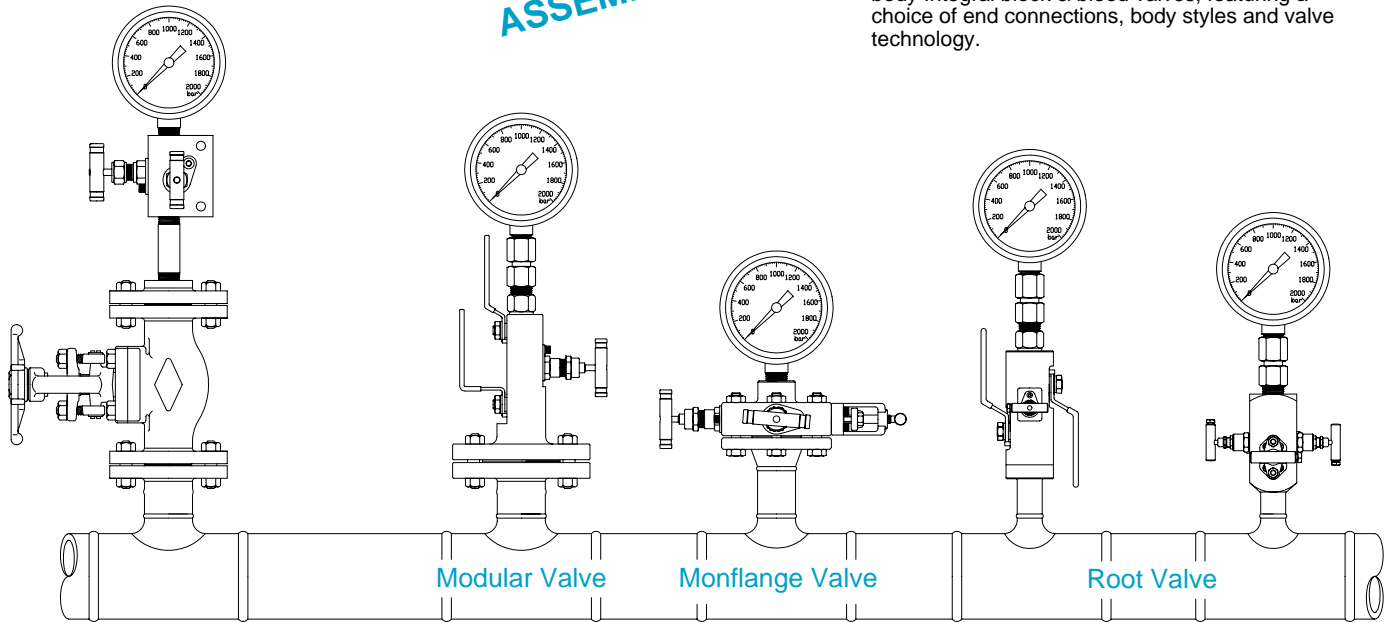

**Modular Valve**

Ball and Globe style Needle Valves  
Flange and Threaded Connections  
Integrally Forged Body

**Monoflange Valve**

Globe Style Needle Valves  
Flanged and Threaded Connections  
Slimline Integrally Forged Body

**Root Valve**

Ball and Globe Style Needle Valves  
Weld or Threaded Connections  
Direct Connection to the Vessel  
Integrally Forged Body

**APPLICATION**

- Double block and bleed instrument isolation
- Gauge isolation
- Instrument drain
- Chemical injection connection
- Sample connections
- Chemical seal instrument isolation
- Piping / instrument interface
- Direct mounting of instruments
- Remote mounting of instruments

**ADVANTAGES**

- More compact design
- Reduced weight
- Reduced height
- Reduced leakage points
- Reduced effect of system vibration
- Supporting brackets are not required
- Reduced bending moment acting on the vessel branch fitting weld
- Reduced installation cost
- Reduced gaskets and bolting

**MARKETS**

- Offshore oil and gas production
- Onshore terminals
- Chemical, petro-chemical, refining
- Control panel manufacturers
- Process/power industry contractors
- Compressor manufacturers
- LNG Carriers

## GENERAL

### Design

ANSI/ASME B16.34  
 -Material wall thickness  
 ANSI/ASME B16.5  
 -Flange dimensions  
 ASME VIII  
 -Design procedures materials  
 ANSI/ASME B1.20.1  
 -National pipe threads  
 API 607/BS 6755  
 -Fire tested

### Tough Handles

Rugged, 316 stainless steel, low torque, quarter turn handles will not rust in offshore service.

### Quality Assurance

All quality assurance performance shall be applied with ISO 9001, API 6D, CE procedure.

### Traceability

All major pressure containing components exhibit unique identification coding and material test certificates, to EN 10204 3.1.B.

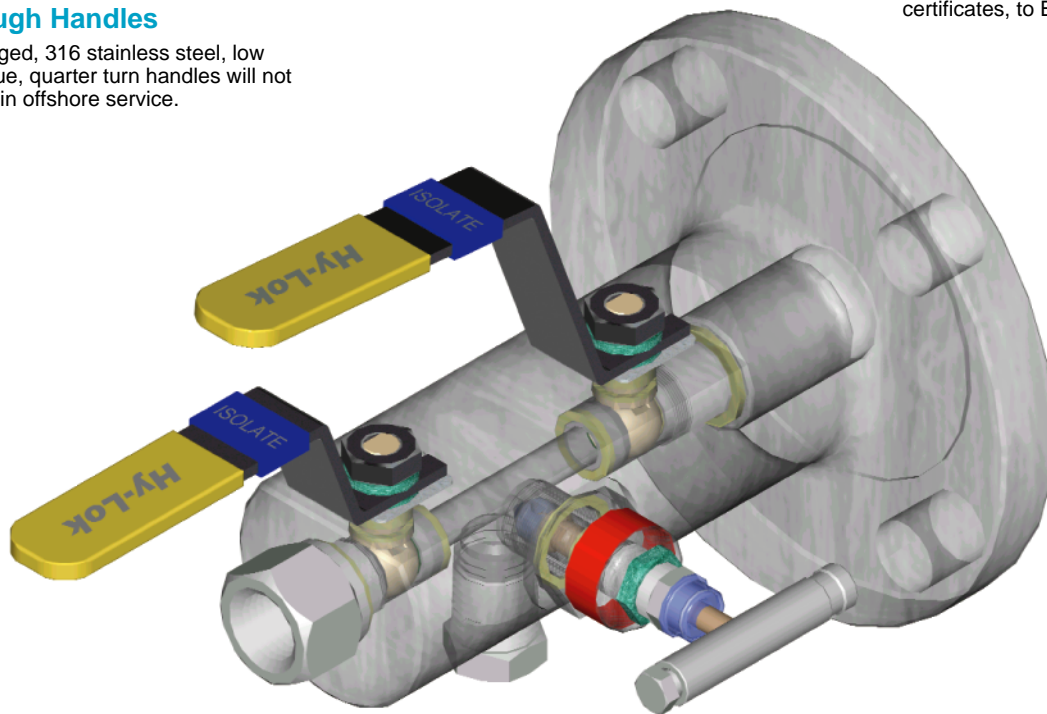

### Positive Stop Pins

A 316 stainless steel pin held into the body by a machined anti-vibration spline assures an absolute 90° turn.

### Testing

All products receive hydrostatic testing at the full rated pressure with proof shell test at 1.5 times full rated pressure and pneumatic test of the seats at 100psi thereby ensuring suitability for use across a wide operating range. And a 1.1 times full rated hydrostatic seat test.

### High Performance Seats

Unique enclosed seats offer great process compatibility but restrict creep or distortion in service. Our approach achieves high levels of seat integrity at low and high pressures.

### Sour Service

Compliance to NACE specification MR 01-75 latest revision-suitable for sour service- resistant to sulphide stress corrosion cracking.

### Flanged Valve Ratings

Comply with, and are affected by, the material class pressure and temperatures of ANSI B16.5 unless the temperature limitations above apply. For clarification consult Hy-Lok Corporation.



## BALL VALVE

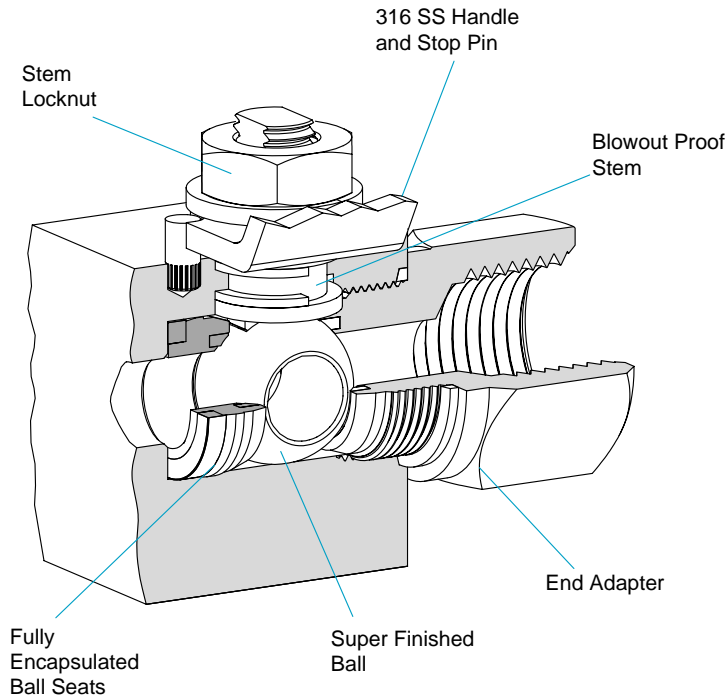

### Features

- Stainless steel handle and positive machined stop.
- Full grip PVC handle sleeve.
- Blowout proof one-piece stem spindle.
- Low operating torque.
- Fully encapsulated ball seats minimize seat seal extrusion and allow high working pressures.
- Super finished ball for low operating torque and long life.
- End adapter threads are fully isolated from process by primary and secondary static seals.
- Stem locknut is vibration resistant to avoid working loose.
- Color coded and function identified handles.
- Firesafe to API 607, BS 6755 part2.
- Bore size available 0.4"(10mm), 0.55"(14mm).
- Ball seats choice of seat materials: PVDF, PTFE(virgin or filled), PCTFE or PEEK.
- Anti-static design as standard.
- Pressure rating up to 10,000psig (690barg).
- Temperature rating -70.6 °F to +482 °F (-57 °C to +250 °C).
- Optional : NACE compliance, Handle Locking Device, Full bore size.

### Pressure and Temperature Ratings

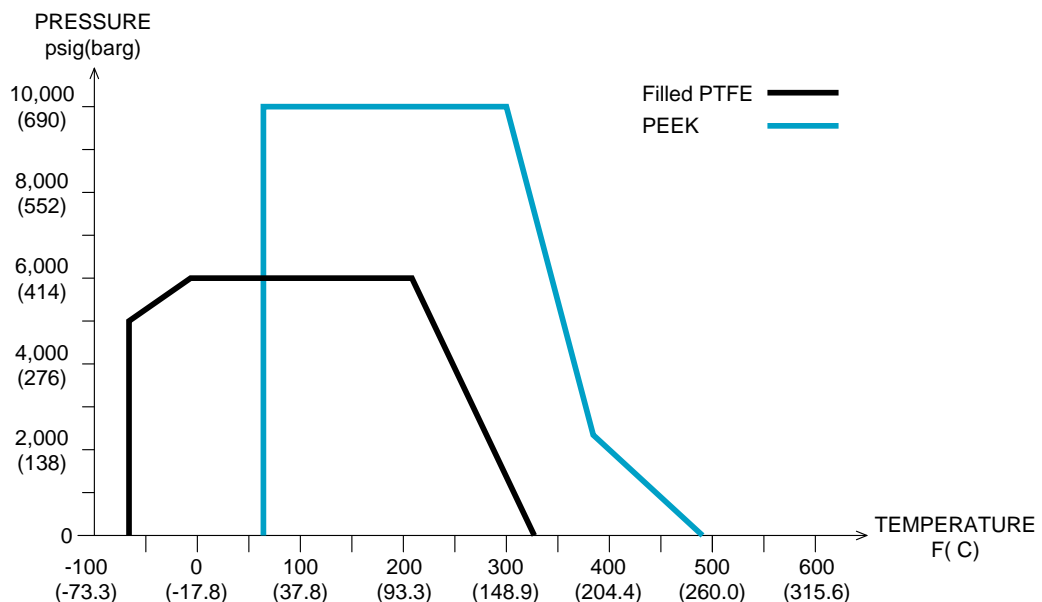

## OS&Y NEEDLE TYPE GLOBE VALVE

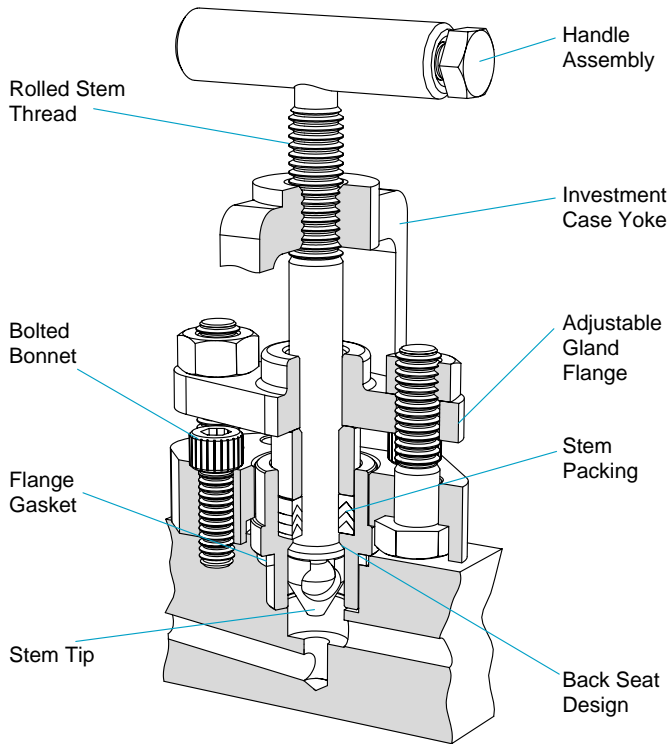

### Features

- Rolled stem threads prevent galling. Stem threads are completely isolated from the process.
- Stem packing with Graphite or PTFE rings for bubble-tight seal.
- Bolted bonnet for strength and reliability.
- Stem tip construction : non-rotating self-centering, Anti-galling tip positive bubble-tight and field interchangeable tip.
- Flange gasket seal ensures a bubble-tight between body and bonnet.
- Backseat design provides secondary stem sealing and prevents stem blowout.
- Adjustable gland flange allows easy access to the packing gland, and packing adjustment for an effective stem seal.
- Investment cast yoke is precision casted for strength and perfect stem alignment.
- Robust bar handle is standard.
- Color coded and function label for easy identification.
- Firesafe to API 607, BS 6755 part2.
- Orifice size 0.2"(5mm).
- Pressure rating up to 6,000psig (414barg).
- Temperature rating -70.6 °F to +1022 °F (-57 °C to +550 °C).

### Pressure and Temperature Ratings

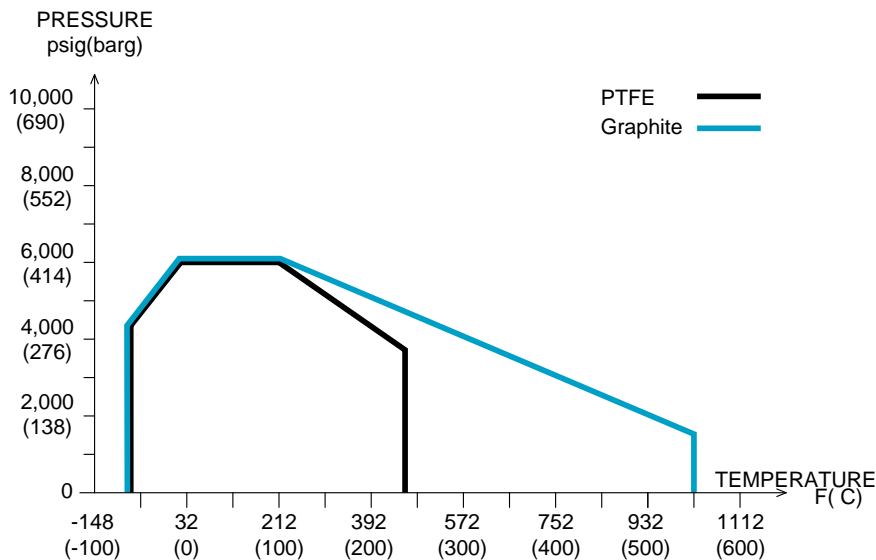

## NEEDLE TYPE GLOBE VALVE

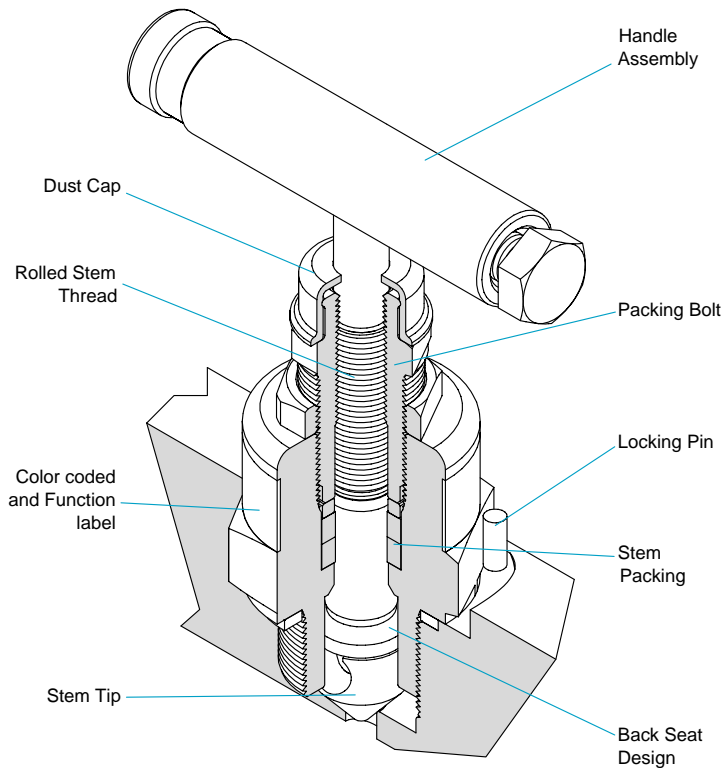

### Features

- Rolled stem threads prevent galling. Stem threads are completely isolated from the process.
- Stem packing with Graphite or PTFE rings for bubble-tight seal.
- Stem tip construction : non-rotating self-centering, Anti-galling tip positive bubble-tight and field interchangeable tip.
- Backseat design provides secondary stem sealing and prevents stem blowout.
- Packing bolt allows easy access to adjust the packing gland.
- Robust bar handle is standard.
- Color coded and function label for easy identification.
- Firesafe to API 607, BS 6755 part2.
- Orifice size 0.2"(5mm).
- Pressure rating up to 10,000psig (690barg).
- Temperature rating -70.6 °F to +1022 °F (-57 °C to +550 °C).
- Anti-Temper bonnets are available with a removable T-bar key to prevent unauthorized operation of vent valves.

### Pressure and Temperature Ratings

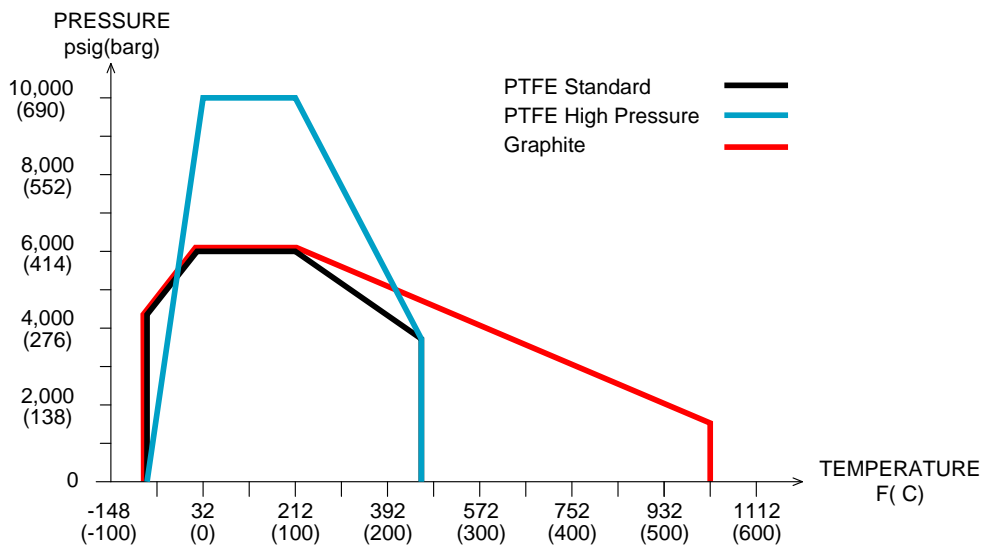



TYPE	DESCRIPTION	MATERIAL				
MODULAR	Body / End Connector	A182 F51	A182 F316	A350 LF2	A105	UNS N04400
MONOFLANGE		A182 F51	A182 F316	A350 LF2	A105	UNS N04400
ROOT VALVE		UNS-S31803	A479 TYPE316	A350 LF2	A105	UNS N04400
Ball Valve	Ball	UNS-S31803	A479 TYPE316			UNS N04400
	Stem	UNS-S31803	A479 TYPE316			UNS N04400
	Retainer	UNS-S31803	A479 TYPE316			UNS N04400
	Socket	UNS-S31803	A479 TP316		A105	UNS N04400
	Ball Seat	PVDF, PTFE(virgin or filled), PCTFE or PEEK				
OS&Y Needle Type Globe Valve	Stem Tip	UNS-S31803	A564 TP630			UNS N04400
	Stem	UNS-S31803	A479 TYPE316			UNS N04400
	Bonnet	UNS-S31803	A479 TYPE316			UNS N04400
	Yoke	A351 CF8M				
Needle Type Globe Valve	Stem Tip	UNS-S31803	A564 TP630			UNS N04400
	Stem	UNS-S31803	A479 TYPE316			UNS N04400
	Bonnet	UNS-S31803	A479 TYPE316			UNS N04400

**NOTE.**

Stainless steel is standard body material but such a Monel, Duplex, Super Duplex, Hasteloy, Inconel and other special material are available upon request.

**Modular Valves** are integrally forged, one-piece double block and bleed assemblies for primary isolation of pressure take-offs, where the valve is directly mounted to the vessel or process pipe. Instruments may be directly mounted to the valve outlet or alternatively remotely with gauge lines/impulse pipe work.

**Applications**

- Block and Bleed(SB Series)
- Double Block and Bleed(DB Series)
- Pressure Measurement
- Chemical Injection
- Level Measurement
- Sampling
- Flow Measurement

**Standard Features**

- ANSI B16.5 flanged Inlet connections 1/2" to 2" sizes.
- Class150 rated to Class2500 rated.
- API flanged Inlet connections sizes to 2 1/16".
- 1/2" NPT threaded female outlet to ANSI/ASME B1.20.1.
- 1/2" NPT threaded female vent connection to ANSI/ASME B1.20.1.
- Material thickness to ANSI B16.34.
- Bolted Body construction (Inlet or Outlet) is options.
- Firesafe to API 607, BS6755 Part2.

**Standard Pressure Testing**

to BS6755 Part1.

**Standard Material Traceability**

to EN 10204 3.1.B (Body only).

**Ball Isolation Valve Seat Materials**

a choice of PVDF, PTFE(virgin or filled), PCTFE and PEEK are available.

**OS&Y Needle Type and Needle Type Globe Valve Packing Materials**

Standard valves are offered with Graphite. PTFE is also available as an option.

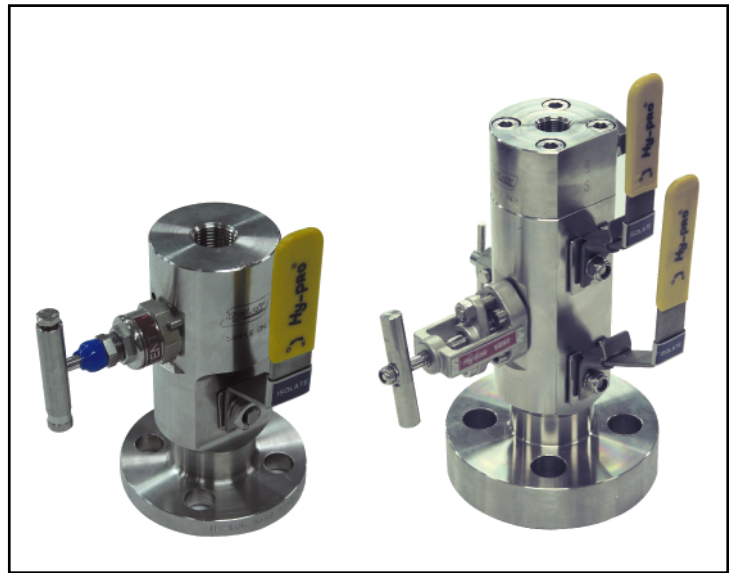

**SB50 SERIES**

Single Block & Bleed Valve  
Flange x 1/2"NPT  
Isolate : Ball  
Bleed : Ball or OS & Y or Needle

**DB50 SERIES**

Double Block & Bleed Valve  
Flange x 1/2"NPT  
Primary : Ball  
Secondary : Ball  
Bleed : OS & Y or Needle

**SB55 SERIES**

Single Block & Bleed Valve  
Flange x 1/2"NPT  
Isolate : OS & Y or Needle  
Bleed : OS & Y or Needle

**DB55 SERIES**

Double Block & Bleed Valve  
Flange x 1/2"NPT  
Primary : OS & Y  
Secondary : OS & Y or Needle  
Bleed : OS & Y or Needle

**SB60 SERIES**

Single Block & Bleed Valve  
Flange x Flange  
Primary : Ball  
Bleed : Ball or OS & Y or Needle

**DB60 SERIES**

Double Block & Bleed Valve  
Flange x Flange  
Primary : Ball  
Secondary : Ball  
Bleed : OS & Y or Needle

**SB65 SERIES**

Single Block & Bleed Valve  
Flange x Flange  
Primary : OS & Y  
Bleed : OS & Y or Needle

**DB65 SERIES**

Double Block & Bleed Valve  
Flange x Flange  
Primary : OS & Y  
Secondary : OS & Y or Needle  
Bleed : OS & Y or Needle

DB50 Series

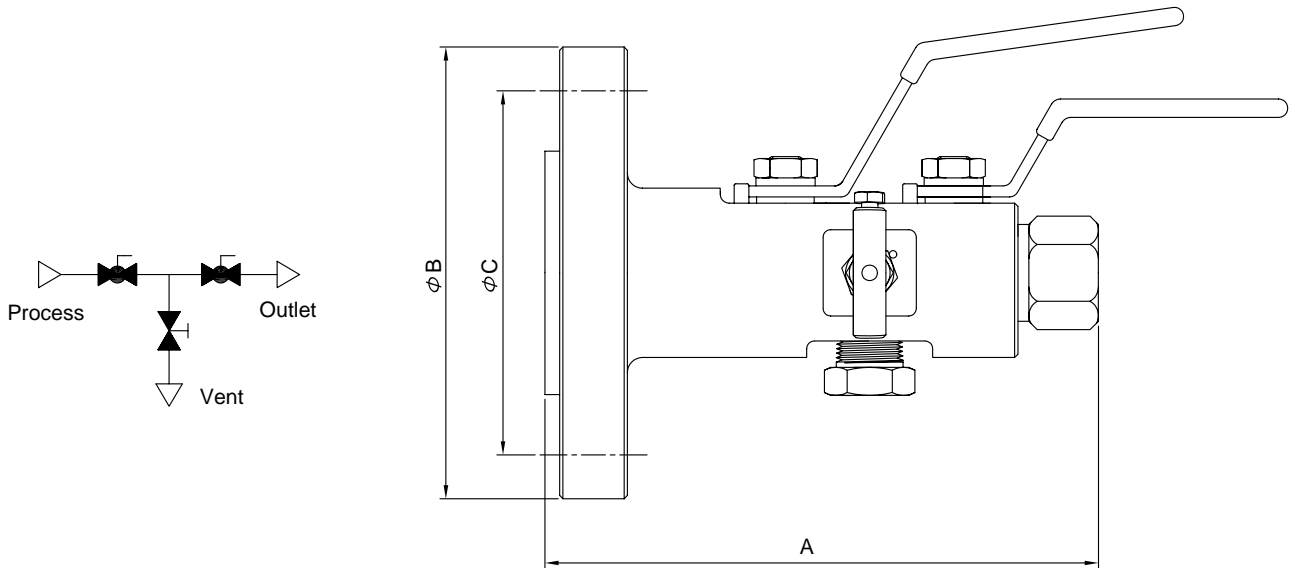

•Dimensions & Weights

SIZE (inch)	RATING lb	DIMENSIONS (mm)				Weight (kg)
		A (RF)	A (RTJ)	B	C	
1/2	150	188	-	89	60.3	3.6
1/2	300	188	193	96	66.7	3.9
1/2	600	188	196	96	66.7	4.0
1/2	900/1500	206	213	121	82.5	5.4
1/2	2500	206	213	134	88.9	6.9
3/4	150	188	-	99	69.8	3.9
3/4	300	188	196	118	82.5	4.6
3/4	600	188	196	118	82.5	4.7
3/4	900/1500	206	213	130	88.9	6.3
3/4	2500	206	213	140	95.2	7.5
1	150	178	183	108	79.4	4.0
1	300	180	185	124	88.9	4.6
1	600	180	188	124	88.9	4.7
1	900/1500	191	198	150	101.6	7.0
1	2500	206	206	159	108.0	8.6
1 1/2	150	180	185	127	98.4	4.6
1 1/2	300	183	188	156	114.3	6.0
1 1/2	600	193	193	156	114.3	6.5
1 1/2	900/1500	203	203	178	123.8	9.4
1 1/2	2500	216	216	203	146.1	15.9
2	150	183	188	153	120.6	6.6
2	300	185	192	165	127.0	8.0
2	600	196	197	165	127.0	8.3
2	900/1500	226	210	216	165.1	15.0
2	2500	221	223	235	171.5	22.0

Dimensions are for reference only, subject to change.

DB55 / SB50 / SB55 Series

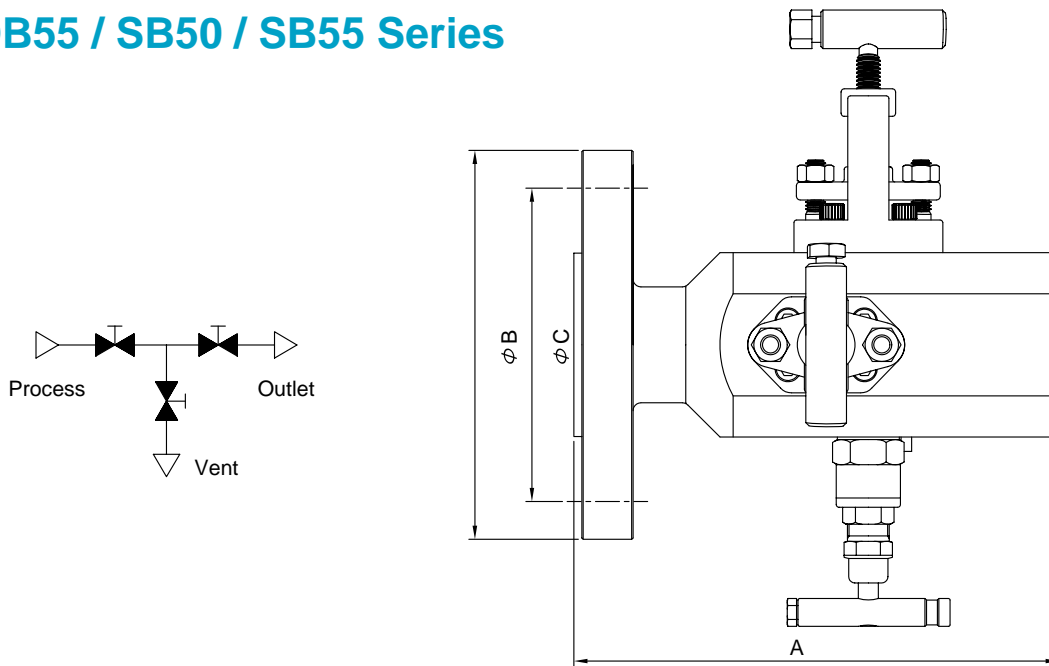

•Dimensions & Weights

SIZE (inch)	RATING lb	DIMENSIONS (mm)				Weight (kg)
		A (RF)	A (RTJ)	B	C	
1/2	150	161	-	89	60.3	3.6
1/2	300	161	163	96	66.7	3.9
1/2	600	166	165	96	66.7	4.0
1/2	900/1500	184	184	121	82.5	5.4
1/2	2500	184	184	134	88.9	6.9
3/4	150	161	-	99	69.8	3.9
3/4	300	161	165	118	82.5	4.6
3/4	600	166	165	118	82.5	4.7
3/4	900/1500	184	184	130	88.9	6.3
3/4	2500	184	184	140	95.2	7.5
1	150	156	161	108	79.4	4.0
1	300	159	164	124	88.9	4.6
1	600	159	166	124	88.9	4.7
1	900/1500	169	177	150	101.6	7.0
1	2500	183	183	159	108.0	8.6
1 1/2	150	159	164	127	98.4	4.6
1 1/2	300	162	167	156	114.3	6.0
1 1/2	600	170	170	156	114.3	6.5
1 1/2	900/1500	180	180	178	123.8	9.4
1 1/2	2500	193	194	203	146.1	15.9
2	150	161	166	153	120.6	6.6
2	300	164	170	165	127.0	8.0
2	600	173	175	165	127.0	8.3
2	900/1500	186	188	216	165.1	15.0
2	2500	199	201	235	171.5	22.0

Dimensions are for reference only, subject to change.

DB60 Series

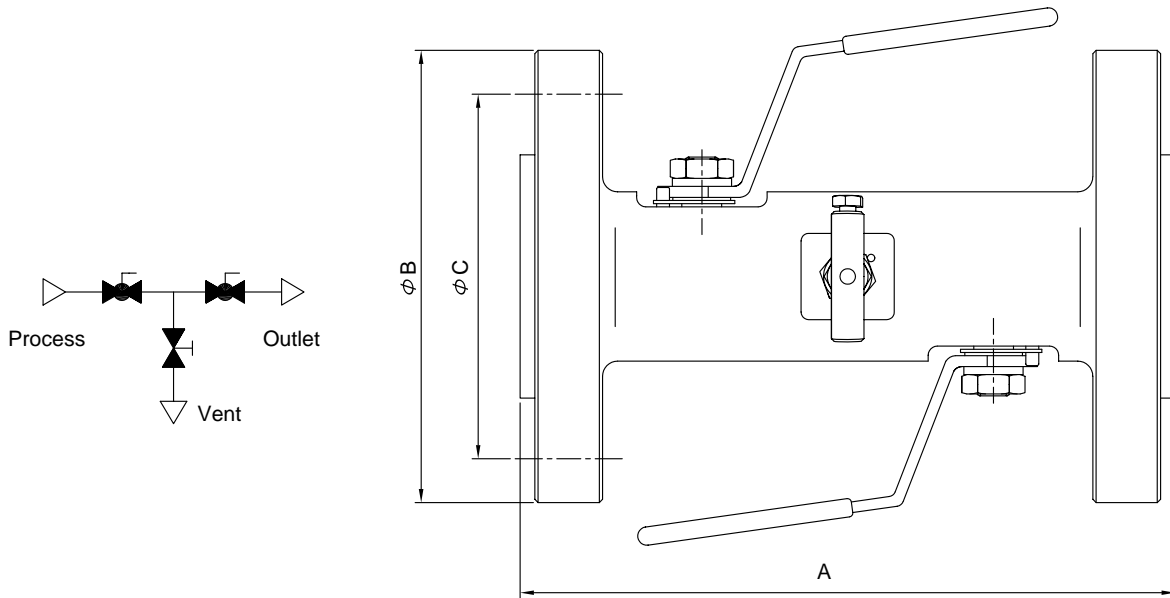

•Dimensions & Weight/s

SIZE (inch)	RATING lb	DIMENSIONS (mm)				Weight (kg)
		A (RF)	A (RTJ)	B	C	
1/2	150	208	-	89	60.3	4.3
1/2	300	208	221	96	66.7	5.0
1/2	600	208	221	96	66.7	5.2
1/2	900/1500	243	256	121	82.5	7.9
1/2	2500	243	256	134	88.9	10.8
3/4	150	208	-	99	69.8	4.9
3/4	300	208	221	118	82.5	6.3
3/4	600	208	221	118	82.5	6.5
3/4	900/1500	243	256	130	88.9	9.5
3/4	2500	243	256	140	95.2	12.0
1	150	180	189	108	79.4	5.0
1	300	186	196	124	88.9	6.3
1	600	199	199	124	88.9	6.5
1	900/1500	221	221	150	101.6	11.2
1	2500	234	234	159	108.0	14.3
1 1/2	150	186	196	127	98.4	6.4
1 1/2	300	192	202	156	114.3	9.1
1 1/2	600	208	208	156	114.3	10.1
1 1/2	900/1500	227	227	178	123.8	16.0
1 1/2	2500	253	256	203	146.1	27.8
2	150	189	199	153	120.6	9.9
2	300	196	208	165	127.0	11.9
2	600	215	218	165	127.0	13.4
2	900/1500	240	243	216	165.1	27.2
2	2500	265	268	235	171.5	40.0

Dimensions are for reference only, subject to change.

DB65 / SB60 / SB65 Series

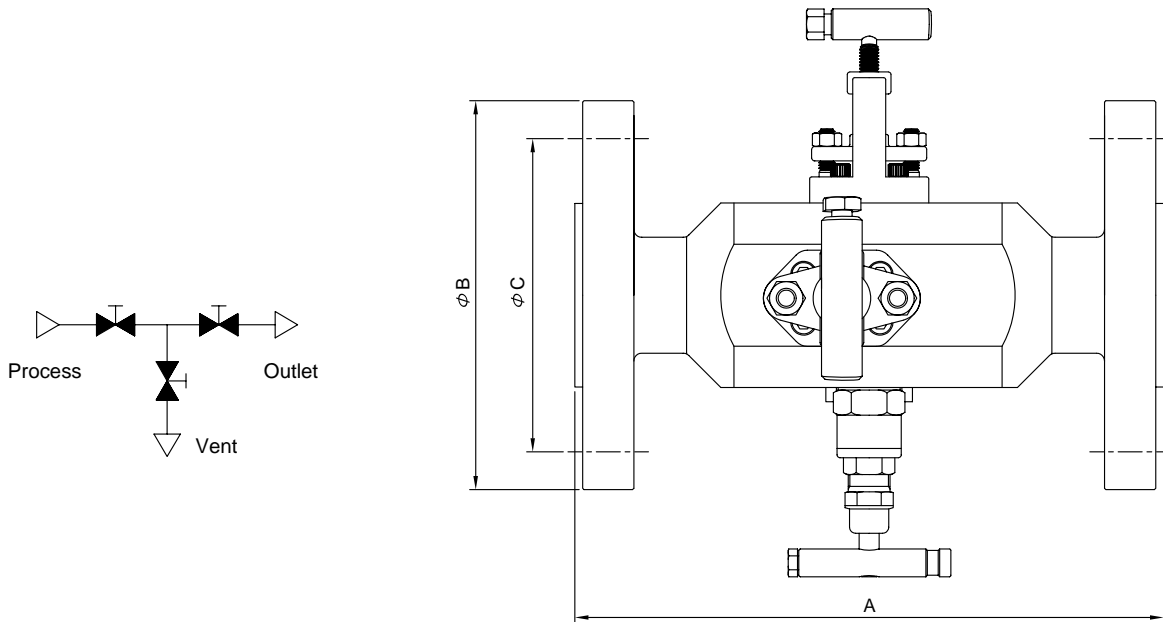

•Dimensions & Weight/s

SIZE (inch)	RATING lb	DIMENSIONS (mm)				Weight (kg)
		A (RF)	A (RTJ)	B	C	
1/2	150	197	-	89	60.3	4.3
1/2	300	197	206	96	66.7	5.0
1/2	600	206	206	96	66.7	5.2
1/2	900/1500	243	243	121	82.5	7.9
1/2	2500	243	243	134	88.9	10.8
3/4	150	197	-	99	69.8	4.9
3/4	300	197	206	118	82.5	6.3
3/4	600	206	206	118	82.5	6.5
3/4	900/1500	243	243	130	88.9	9.5
3/4	2500	243	243	140	95.2	12.0
1	150	180	189	108	79.4	5.0
1	300	186	196	124	88.9	6.3
1	600	199	199	124	88.9	6.5
1	900/1500	221	221	150	101.6	11.2
1	2500	234	234	159	108.0	14.3
1 1/2	150	186	196	127	98.4	6.4
1 1/2	300	192	202	156	114.3	9.1
1 1/2	600	208	208	156	114.3	10.1
1 1/2	900/1500	227	227	178	123.8	16.0
1 1/2	2500	253	256	203	146.1	27.8
2	150	189	199	153	120.6	9.9
2	300	196	208	165	127.0	11.9
2	600	215	218	165	127.0	13.4
2	900/1500	240	243	216	165.1	27.2
2	2500	265	268	235	171.5	40.0

Dimensions are for reference only, subject to change.



### SAMPLING VALVE

Sampling the process stream can be accomplished with this valve design, where a sampling can be taken even at full system pressure directly from the process line. The product allows double isolations from process for safety.

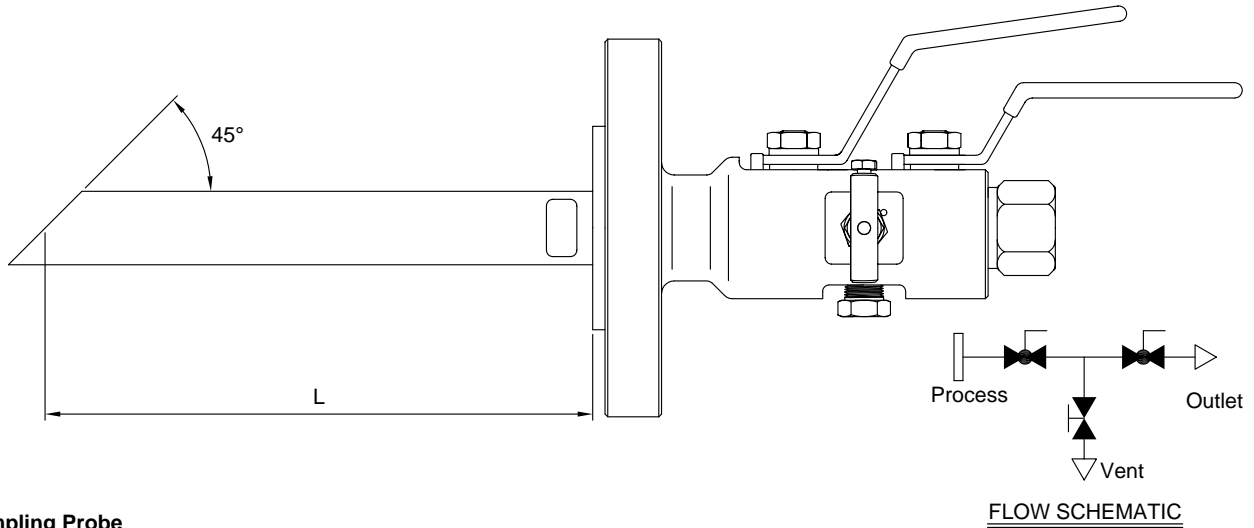

**Sampling Probe**

The Sampling Probe length(L) is manufactured to suit customer requirements.

### CHEMICAL INJECTION VALVE

Injection of chemicals and other media into the process stream can be accomplished with this valve design. The valve inlet houses a one way check valve which opens for injection and goes normally closed to eliminate process fluid outflow.

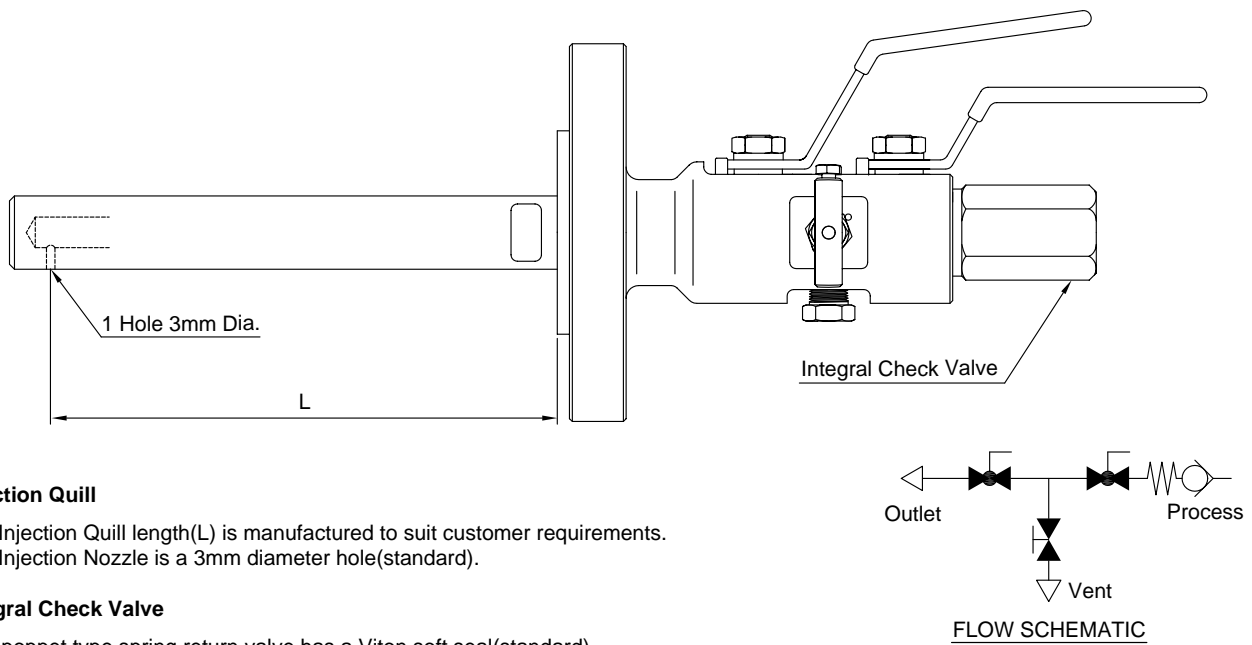

**Injection Quill**

The Injection Quill length(L) is manufactured to suit customer requirements. The Injection Nozzle is a 3mm diameter hole(standard).

**Integral Check Valve**

This poppet type spring return valve has a Viton soft seal(standard).

## Monoflange Valves

are integrally forged, one-piece double block and bleed assemblies for primary isolation of pressure take-offs, where the valve is directly mounted to the vessel or process pipe. Instruments may be directly mounted to the valve outlet or alternatively remotely with gauge lines/impulse pipe work.

## Applications

- Isolation(MF45)
- Block and Bleed(MF55)
- Double Block and Bleed(MF65)
- Pressure Measurement
- Chemical Injection
- Level Measurement
- Sampling
- Flow Measurement

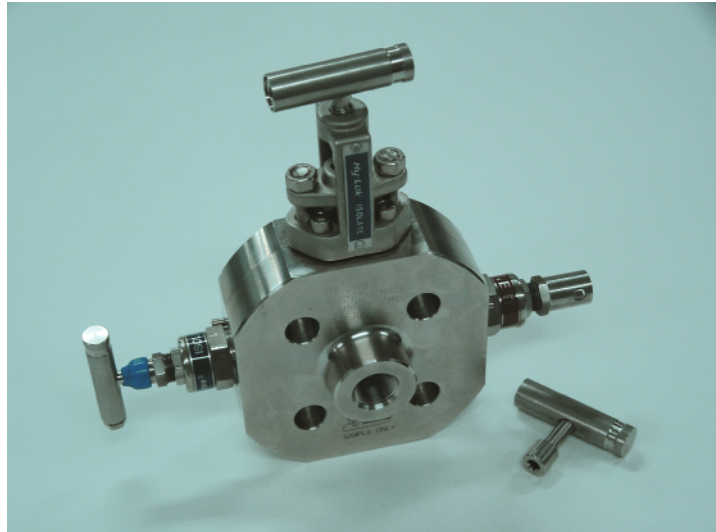

## Standard Features

- ANSI B16.5 flanged Inlet connections 1/2" to 2" sizes.
- Class150 rated to Class2500 rated.
- API flanged Inlet connections sizes to 2 1/16".
- 1/2" NPT threaded female outlet to ANSI/ASME B1.20.1.
- 1/2" NPT threaded female vent connection to ANSI/ASME B1.20.1.
- Material thickness to ANSI B16.34.
- Firesafe to API 607, BS6755 Part2.

## Standard Pressure Testing

to BS6755 Part1.

## Standard Material Traceability

to EN 10204 3.1.B (Body only).

## OS&Y Needle Type and Needle Type Globe Valve Packing Materials

Standard valves are offered with Graphite. PTFE is also available as an option.

### **MN45 SERIES**

- Single Block Valve
- Flange x 1/2"NPT
- Isolate : OS&Y or Needle

### **MN55 SERIES**

- Single Block & Bleed Valve
- Flange x 1/2"NPT
- Isolate : OS&Y or Needle
- Bleed : OS&Y or Needle

### **MN65 SERIES**

- Double Block & Bleed Valve
- Flange x 1/2"NPT
- Primary : OS&Y or Needle
- Secondary : OS&Y or Needle
- Bleed : OS&Y or Needle

MN45 Series

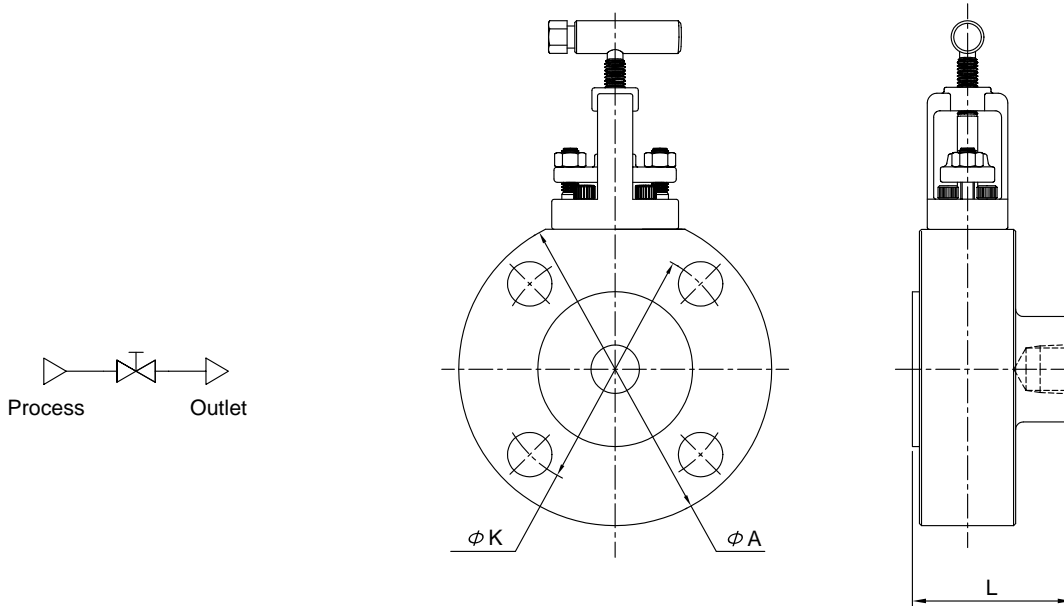

•Dimensions & Weights

SIZE (inch)	RATING lb	DIMENSIONS (mm)				Weight (kg)
		L (RF)	L (RTJ)	A	K	
1/2	150	64	-	99	60.3	2.0
1/2	300	64	68	99	66.7	2.0
1/2	600	68	68	99	66.7	2.0
1/2	900/1500	68	68	133	82.5	3.4
1/2	2500	68	68	133	88.9	3.4
3/4	150	64	-	99	69.8	2.0
3/4	300	64	68	133	82.5	3.4
3/4	600	68	68	133	82.5	3.4
3/4	900/1500	68	68	133	88.9	3.4
3/4	2500	73	73	159	95.2	5.5
1	150	64	68	133	79.4	2.4
1	300	64	68	133	88.9	3.4
1	600	68	68	133	88.9	3.4
1	900/1500	73	73	159	101.6	5.5
1	2500	73	73	159	108.0	5.5
1 1/2	150	64	68	127	98.4	3.2
1 1/2	300	69	69	159	114.3	5.5
1 1/2	600	73	73	159	114.3	5.5
1 1/2	900/1500	73	73	178	123.8	7.8
1 1/2	2500	82	84	235	146.1	11.4
2	150	69	73	159	120.6	5.5
2	300	69	75	178	127.0	7.8
2	600	73	75	178	127.0	7.8
2	900/1500	82	84	235	165.1	11.4

Dimensions are for reference only, subject to change.

MN55 Series

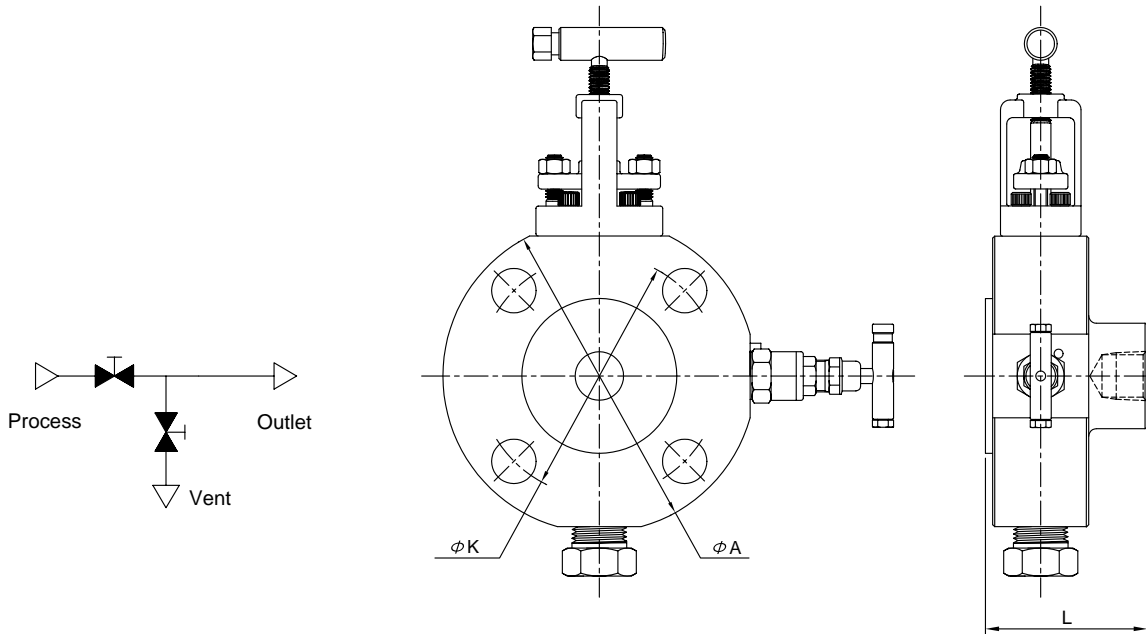

•Dimensions & Weights

SIZE (inch)	RATING lb	DIMENSIONS (mm)				Weight (kg)
		L (RF)	L (RTJ)	A	K	
1/2	150	64	-	99	60.3	2.0
1/2	300	64	68	99	66.7	2.0
1/2	600	68	68	99	66.7	2.0
1/2	900/1500	68	68	133	82.5	3.4
1/2	2500	68	68	133	88.9	3.4
3/4	150	64	-	99	69.8	2.0
3/4	300	64	68	133	82.5	3.4
3/4	600	68	68	133	82.5	3.4
3/4	900/1500	68	68	133	88.9	3.4
3/4	2500	73	73	159	95.2	5.5
1	150	64	68	133	79.4	2.4
1	300	64	68	133	88.9	3.4
1	600	68	68	133	88.9	3.4
1	900/1500	73	73	159	101.6	5.5
1	2500	73	73	159	108.0	5.5
1 1/2	150	64	68	127	98.4	3.2
1 1/2	300	69	69	159	114.3	5.5
1 1/2	600	73	73	159	114.3	5.5
1 1/2	900/1500	73	73	178	123.8	7.8
1 1/2	2500	82	84	235	146.1	11.4
2	150	69	73	159	120.6	5.5
2	300	69	75	178	127.0	7.8
2	600	73	75	178	127.0	7.8
2	900/1500	82	84	235	165.1	11.4

Dimensions are for reference only, subject to change.

MN65 Series

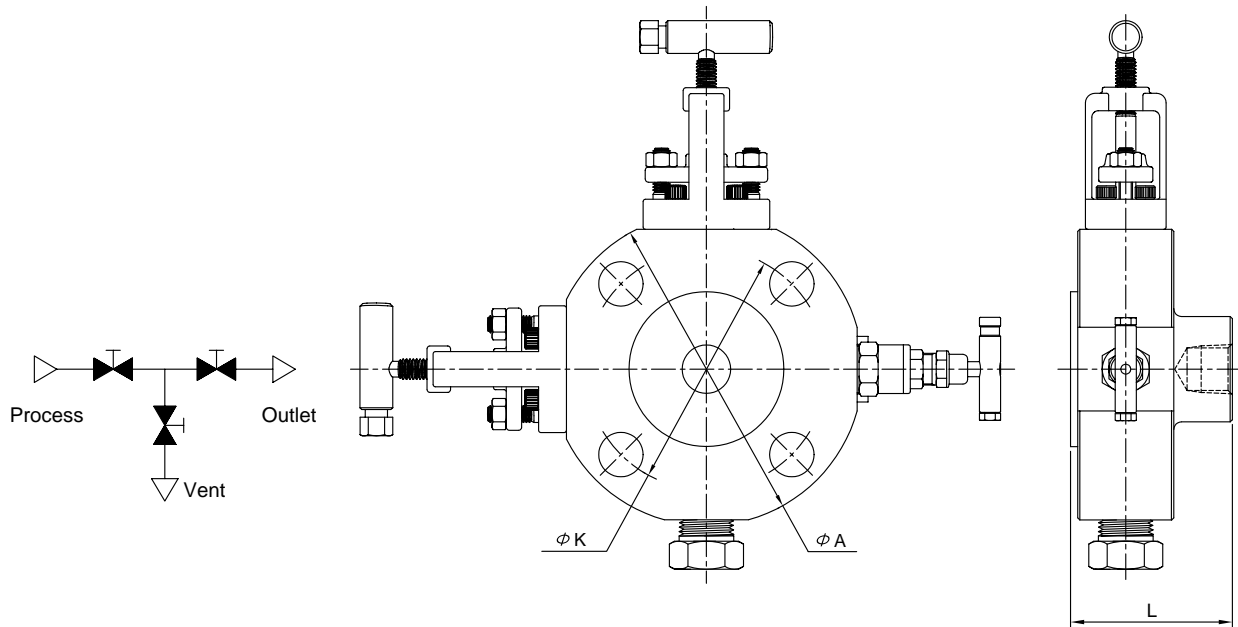

•Dimensions & Weights

SIZE (inch)	RATING lb	DIMENSIONS (mm)				Weight (kg)
		L (RF)	L (RTJ)	A	K	
1/2	150	64	-	99	60.3	2.0
1/2	300	64	68	99	66.7	2.0
1/2	600	68	68	99	66.7	2.0
1/2	900/1500	68	68	133	82.5	3.4
1/2	2500	68	68	133	88.9	3.4
3/4	150	64	-	99	69.8	2.0
3/4	300	64	68	133	82.5	3.4
3/4	600	68	68	133	82.5	3.4
3/4	900/1500	68	68	133	88.9	3.4
3/4	2500	73	73	159	95.2	5.5
1	150	64	68	133	79.4	2.4
1	300	64	68	133	88.9	3.4
1	600	68	68	133	88.9	3.4
1	900/1500	73	73	159	101.6	5.5
1	2500	73	73	159	108.0	5.5
1 1/2	150	64	68	127	98.4	3.2
1 1/2	300	69	69	159	114.3	5.5
1 1/2	600	73	73	159	114.3	5.5
1 1/2	900/1500	73	73	178	123.8	7.8
1 1/2	2500	82	84	235	146.1	11.4
2	150	69	73	159	120.6	5.5
2	300	69	75	178	127.0	7.8
2	600	73	75	178	127.0	7.8
2	900/1500	82	84	235	165.1	11.4

Dimensions are for reference only, subject to change.

**Root Valves** are integrally forged, one-piece double block and bleed assemblies for primary isolation of pressure take-offs, where the valve is directly mounted to the vessel or process pipe. Instruments may be directly mounted to the valve outlet or alternatively remotely with gauge lines/impulse pipe work.

**Applications**

- Isolation(RV4 Series)
- Block and Bleed(RV5 Series)
- Double Block and Bleed(RV6 Series)
- Pressure Measurement
- Flow Measurement

**Standard Features**

- Weld inlet connections 1/2" to 2" sizes
- Class150 rated to Class2500 rated.
- 1/2" NPT threaded female outlet to ANSI/ASME B1.20.1.
- 1/2" NPT threaded female vent connection to ANSI/ASME B1.20.1.
- Material thickness to ANSI B16.34.
- Firesafe to API 607, BS6755 Part2.

**Standard Pressure Testing**

to BS6755 Part1.

**Standard Material Traceability**

to EN 10204 3.1.B (Body only).

**Ball Isolation Valve Seat Material**

A choice of PVDF, PTFE(virgin or filled), PCTFE and PEEK are available.

**OS&Y Needle Type and Needle Type Globe Valve Packing Materials**

Standard valves are offered with Graphite. PTFE is also available as an option.

**Options**

Options requirement are the same as the Modular and Monoflange range.

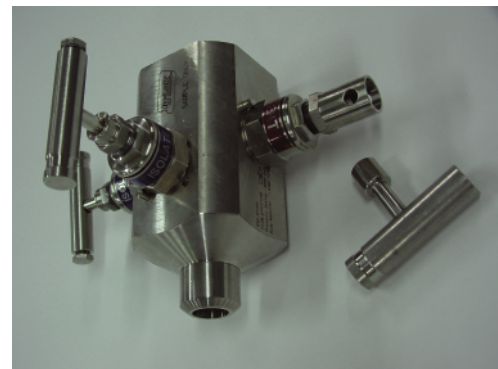

**RV40 SERIES**

Single Block Valve  
Plain End x 1/2"NPT  
Isolate : Ball

**RV45 SERIES**

Single Block Valve  
Plain End x 1/2"NPT  
Isolate : OS&Y or Needle

**RV50 SERIES**

Single Block & Bleed Valve  
Plain End x 1/2"NPT  
Primary : Ball  
Bleed : OS&Y or Needle

**RV55 SERIES**

Single Block & Bleed Valve  
Plain End x 1/2"NPT  
Primary : OS&Y or Needle  
Bleed : OS&Y or Needle

**RV60 SERIES**

Double Block & Bleed Valve  
Plain End x 1/2"NPT  
Primary : Ball  
Secondary : Ball  
Bleed : OS&Y or Needle

**RV65 SERIES**

Double Block & Bleed Valve  
Plain End x 1/2"NPT  
Primary : OS&Y  
Secondary : OS&Y or Needle  
Bleed : OS&Y or Needle



RV40 / RV45 / RV50 Series

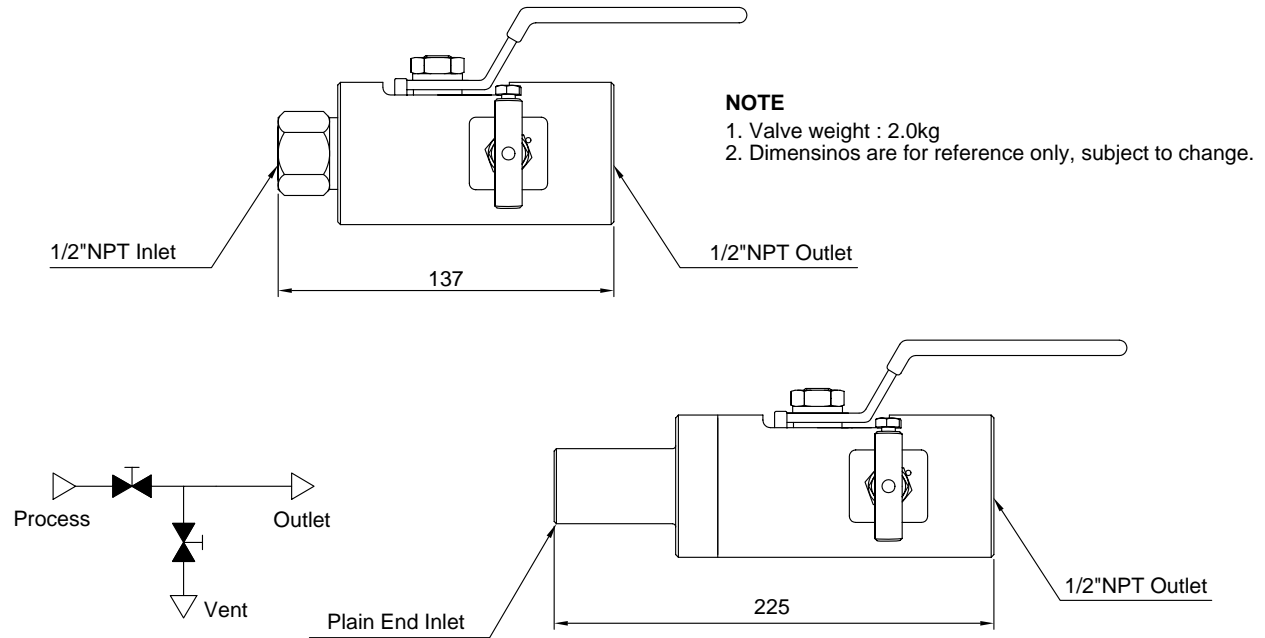

RV60 Series

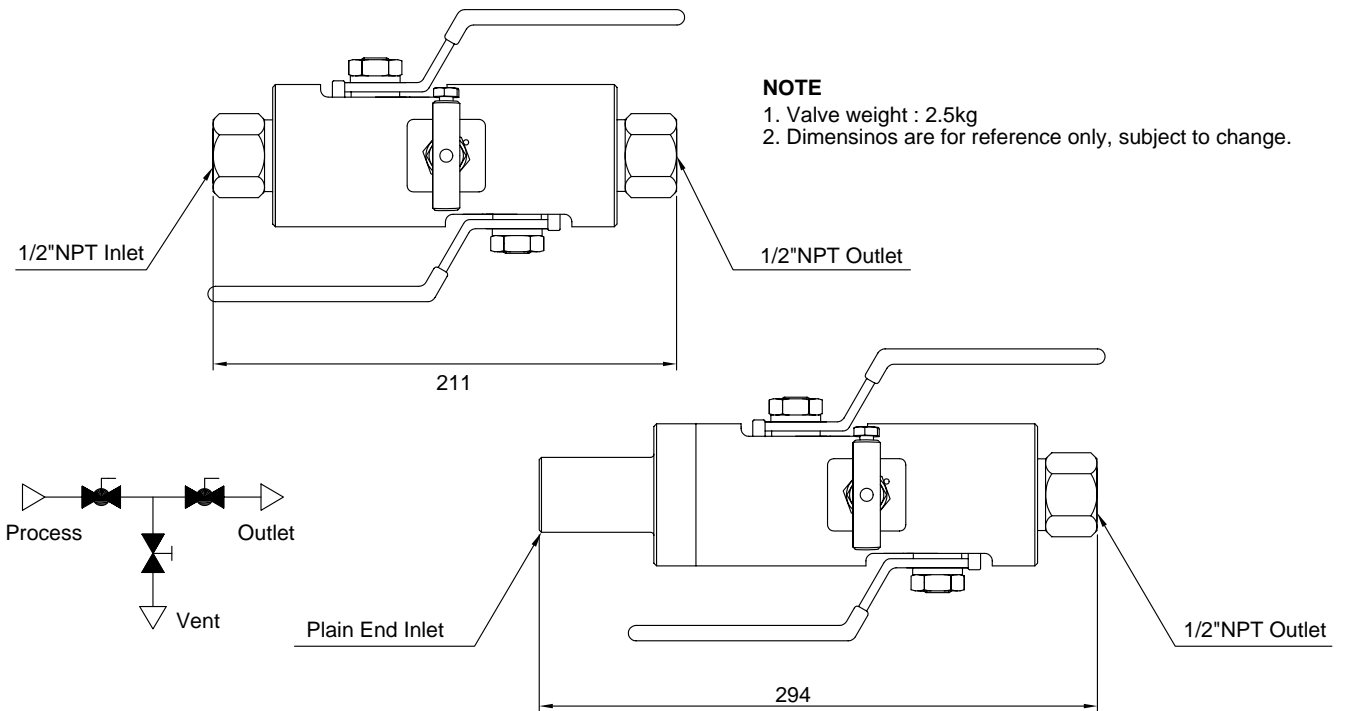

RV55 / RV65 Series

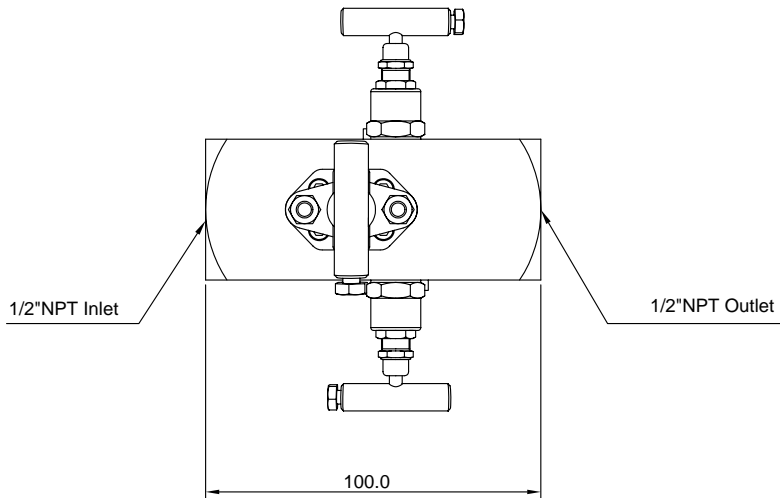

**NOTE**  
 1. Valve weight : 1.7kg  
 2. Dimensinos are for reference only, subject to change.

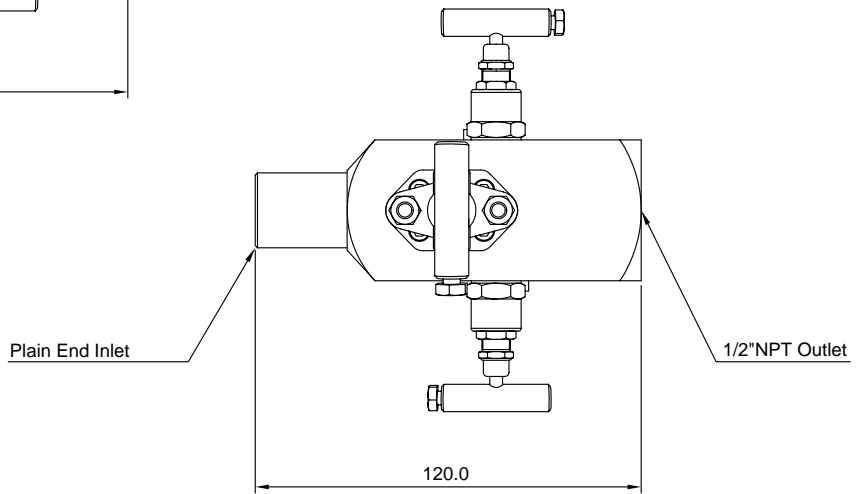
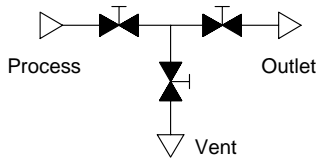

ORDERING INFORMATION

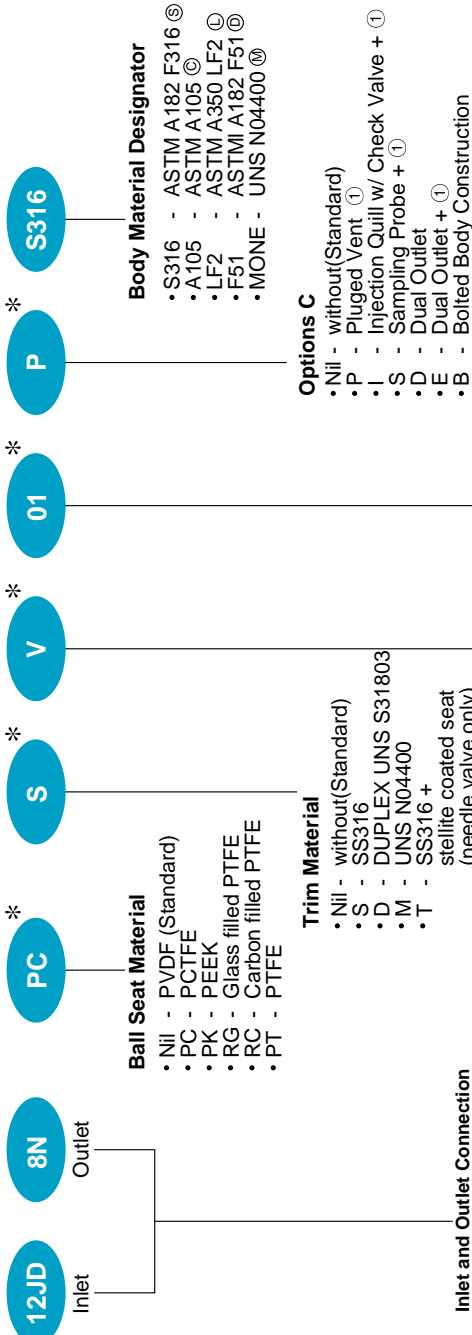

- Valve Series**
- DBA - Single Block & Bleed
- Ball Seat Material**
- Nil - PVDf (Standard)
  - PC - PCTFE
  - PK - PEEK
  - RG - Glass filled PTFE
  - RC - Carbon filled PTFE
  - PT - PTFE
- Trim Material**
- Nil - without(Standard)
  - S - SS316
  - D - DUPLEX UNS S31803
  - M - UNS N04400
  - T - SS316 + stellite coated seat (needle valve only)
- Options B**
- Nil - without(Standard)
  - 01 - NAACE MR-01-75
  - 02 - Anti Tamper on vent
  - 03 - PTFE Packing
  - 04 - 1/4" NPT Bleed Port
  - 05 - 1 + 2
  - 06 - 1 + 3
  - 07 - 1 + 4
  - 08 - 1 + 2 + 3
  - 09 - 1 + 2 + 4
  - 10 - 1 + 2 + 3 + 4
  - 11 - 2 + 3
  - 12 - 2 + 4
  - 13 - 2 + 3 + 4
  - 14 - 3 + 4
- Options C**
- Nil - without(Standard)
  - P - Plugged Vent
  - I - Injection Quill w/ Check Valve + 1
  - S - Sampling Probe + 1
  - D - Dual Outlet
  - E - Dual Outlet + 1
  - B - Bolted Body Construction
  - C - Bolted Body Construction + 1
  - Z - Special Requirements
- Body Material Designator**
- S316 - ASTM A182 F316
  - A105 - ASTM A105
  - LF2 - ASTM A350 LF2
  - F51 - ASTM A182 F51
  - MON6 - UNS N04400

**Inlet and Outlet Connection**

Inch Identifier	Description	Flange		Threads	
		Identifier	Class Identifier	Identifier	Type Identifier
1/4 -4	Spiral Finish Raised Faced	R	150 A	NPT	N
3/8 -6	Smooth Finish Raised Faced	S	300 B	BSPT	R
1/2 -8	Stock Finish Raised Faced	F	600 C	Weld End	
3/4 -12	Ring Type Joint	J	900 D	Butt Weld	BW
1 -16	Stock Finish Flate Faced	L	1500 E	Socket Weld	SW
1 1/2 -24			2500 F		
2 -32					
3 -48					

Standard Construction

- Trim Construction
- C, L and S Body : S Trim
  - D Body : D Trim
  - M Body : M Trim

Ball Valve : Firesafe, Anti-Static, Locking-device

Packing : Graphite

Bore size :

- Ball : 10mm, Needle : 5mm
- but DBE, SBE - Ball : 14mm, Needle : 5mm
- but DBG, SBG - Ball : Full bore, Needle : 5mm
- but DBK, DBL - Ball : 10mm, Needle : 10mm

\*Note

No designator is required for standard items, e.g. DBA-12JD8N-S316(Double Block & Bleed valve)  
 Inlet - 3/4" RTJ Class600 (ANSI/ASME B16.5)  
 Outlet - 1/2" Female NPT  
 Vent : 1/2" Female NPT

**MODULAR - Single Block & Bleed**

Series I.D.	Block	Bleed
SBA	Ball	Needle
SBE	Ball	OS & Y
SB50	Ball	Ball
SB60	Ball	OS & Y
SBG	Ball	OS & Y
Full Bore, Dual Flange		
SBB	OS & Y	OS & Y
SBC	OS & Y	Needle
SB65	Needle	Needle

**MODULAR - Double Block & Bleed**

Series I.D.	Block	Block	Bleed
DBA	Ball	Ball	Needle
DBE	Ball	Ball	OS & Y
DBG	Ball	Ball	OS & Y
Full Bore, Dual Flange			
DBH	Ball	Ball	-
DB60	Ball	Needle	-
DBJ	Ball	Ball	Ball
DBK	Ball	Needle	Needle
DBL	Ball	Needle	Needle
DBB	OS & Y	OS & Y	OS & Y
DB55	DBC	OS & Y	OS & Y
DB65	DBD	Needle	Needle
DBF	OS & Y	Needle	Needle

**MONOFLANGE VALVE**

Series I.D.	Block	Block	Bleed
MNA	OS & Y	-	-
MNB	Needle	-	-
MNC	OS & Y	-	Needle
MND	Needle	-	Needle
MNE	OS & Y	Needle	Needle
MNF	Needle	Needle	Needle

**ROOT VALVE**

Series I.D.	Block	Block	Bleed
RV40	MNA	Ball	-
RV45	MNB	OS & Y	-
RV50	MNC	Ball	-
RV55	MND	OS & Y	-
RV60	MNE	Ball	Needle
RV65	MNF	OS & Y	Needle