



# Product information

## Vibrating

Level detection in liquids

- VEGASWING 51
- VEGASWING 53
- VEGASWING 61
- VEGASWING 63
- VEGASWING 66



## Contents

1	Measuring principle	3
2	Type overview	7
3	Instrument selection	8
4	Instrument features	9
5	Accessories	10
6	Selection criteria	11
7	Housing overview - VEGASWING 61, 63, 66	12
8	Mounting	13
9	Electronics - relay output	14
10	Electronics - transistor output	15
11	Electronics - contactless electronic switch	17
12	Electronics - two-wire output 8/16 mA	18
13	Electronics - NAMUR output	19
14	IO-Link output	20
15	Adjustment	21
16	Dimensions	23

### Take note of safety instructions for Ex applications



Please note the Ex specific safety information that you can find at [www.vega.com](http://www.vega.com) and that comes with each instrument. In hazardous areas you should take note of the appropriate regulations, conformity and type approval certificates of the sensors and power supply units. The sensors must only be operated on intrinsically safe circuits. The permissible electrical values are stated in the certificate.

# 1 Measuring principle

## Measuring principle

VEGASWING is a point level sensor with tuning fork for point level detection.

It is designed for industrial use in all areas of process technology, but preferably in liquids.

The vibrating element (tuning fork) is piezoelectrically energized and vibrates at its mechanical resonance frequency. The piezo elements are mechanically fixed and are hence not subject to temperature shock limitations. If the vibrating element is submerged in the product, the vibrating frequency changes. This change is detected by the integrated electronics module and converted into a switching command.

## Configuration

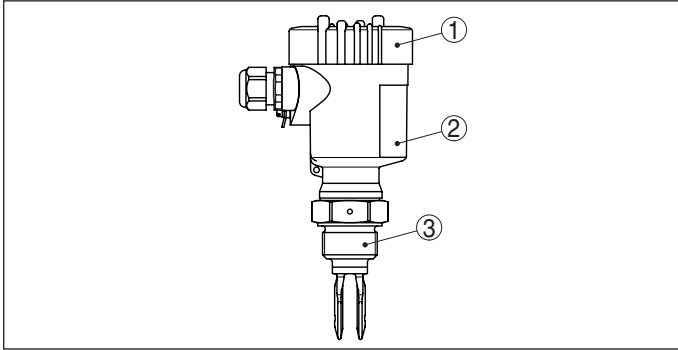

Fig. 1: Vibrating level switch VEGASWING, for example VEGASWING 61 with plastic housing

- 1 Housing lid
- 2 Housing with electronics
- 3 Process fitting

Typical applications are overflow and dry run protection. Thanks to its simple and robust measuring system, VEGASWING is virtually unaffected by the chemical and physical properties of the liquid.

It also works when subjected to strong external vibrations or changing products.

## Function monitoring

The electronics module of VEGASWING continuously monitors the following criteria:

- Strong corrosion or damage on the tuning fork
- Loss of vibration
- Line break to the piezo drive

If one of the stated malfunctions is detected or in case of voltage supply, the electronics takes on a defined switching status, for example the switching output is open (safe state).

## Function test

The recurring function test is used to check the safety function, in order to reveal possible dangerous unrecognized faults. The function of the measuring system must be checked in regular, adequate intervals.

There are two different ways to carry out a function test:

VEGASWING 61, 63, 66 with two-wire electronics in conjunction with a VEGATOR controller.

- Test key on the VEGATOR controller

VEGASWING 61, 63, 66 with two-wire electronics in conjunction with a PLC.

- Brief interruption of the connection cable to the PLC

# 1.2 Application examples

## Chemical industry - Solvents



Fig. 2: Level detection in vessels with solvents

Apart from the continuous level measurement, level detection is an essential safety feature for storage tanks. Many modern sensors for continuous level measurement are actually approved as overflow protection system, however, a second, physically different measuring system provides the best safety and redundancy.

Thanks to their manifold application possibilities, VEGASWING vibrating level switches are ideal for all applications in the area of liquids warehousing. A large number of electrical and mechanical versions ensures simple integration into existing control systems.

Advantages:

- Various electrical versions
- Product-independent
- Universal level detection for all liquids

### Chemical industry - reactors

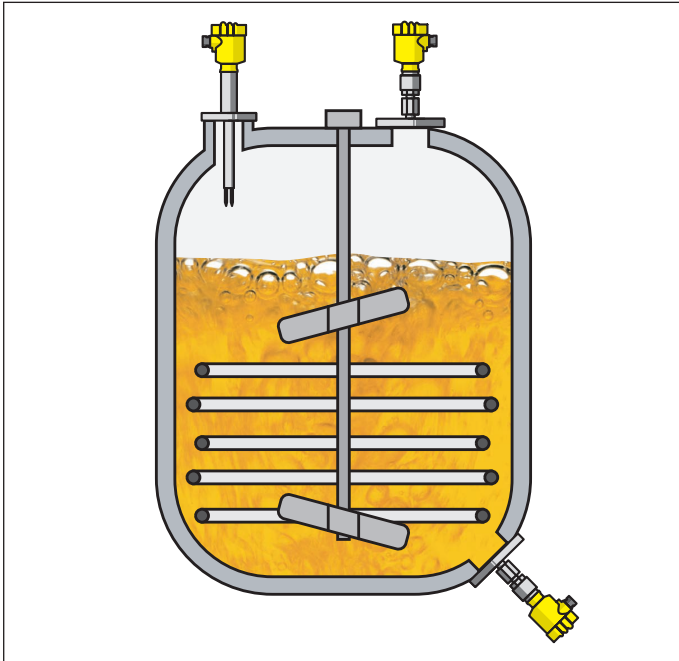

Fig. 3: Level detection in chemical reactors

Because they prevent overflowing or dry running of pumps, sensors for level detection are an important safety element in reactors. Due to their universal applicability, VEGASWING level switches are well suited for use in reaction vessels. Even high viscosities, temperatures up to 250 °C and pressure up to 64 bar do not impair their function.

To provide the required chemical resistance, high resistance materials and enamelled versions are available.

In toxic products, the VEGASWING version with metallic process separation ensures a high level of safety. To prevent product leakage even in case of corrosion on the tuning fork, a glass seal is also welded in. This ensures optimum protection.

To provide optimal resistance to the measured medium, whatever its composition and corrosive properties may be, sensors made of 316L or Alloy, or sensors in plastic-coated and enamelled versions, are available.

Thanks to their manifold application possibilities, VEGASWING vibrating level switches are ideal for all applications in the area of liquids storage. A large number of electrical and mechanical versions enables simple integration into existing control systems.

Advantages:

- Various electrical versions
- Product-independent
- Completely gas-tight
- High reliability
- Universal level detection for all liquids

### Water/Sewage water plants

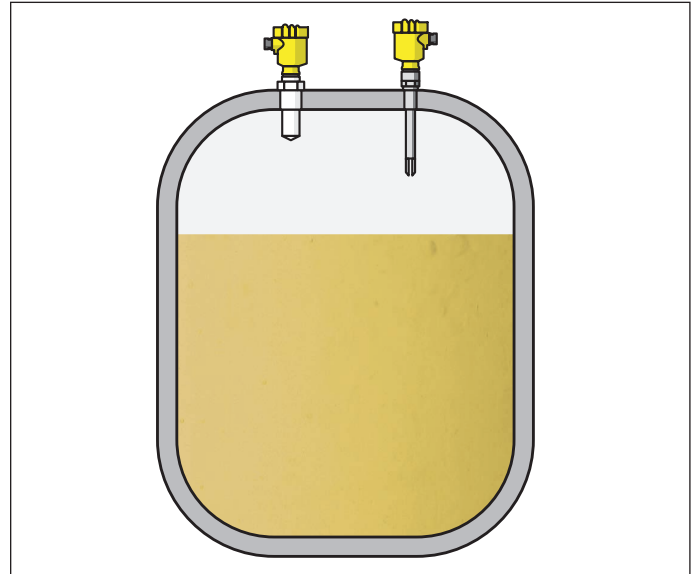

Fig. 4: Precipitants in sewage water processing

Chemicals are required for sewage water treatment. They are applied to promote chemical precipitation. Phosphates and nitrates are thus sedimented and separated. In addition to lime water and ferric chloride, various acids and alkalis are stored for use in digested sludge treatment and neutralisation.

These substances are subject to the regulations covering water-endangering substances. Overflow protection systems thus have to be installed on the storage tanks.

Since they prevent the overflowing of vessels containing toxic products, sensors for level detection are an important safety element.

Due to their versatile nature, VEGASWING vibrating level switches are also well qualified for use with water-endangering substances. To provide optimal resistance to the measured medium, whatever its composition and corrosive properties may be, sensors made of 316L or Alloy, as well as sensors in plastic-coated or enamelled versions, are available.

Advantages:

- Small non-repeatability
- High-resistance sensor materials such as PFA, ECTFE, Alloy C22 (2.4602), enamel

### Pipelines

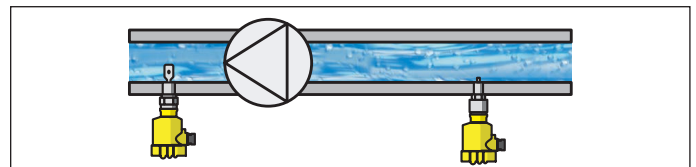

Fig. 5: Dry run protection in pipelines

Monitoring of levels is also important in pipelines, as dry running often causes damage or complete breakdown of the pumps.

The VEGASWING level switch is recommended as dry run protection system, e.g. for drinking water pumps. With a fork only 40 mm (1.575 in) long (VEGASWING series 60), this level switch functions quite reliably, even in pipes with small diameters from DN 32.

Advantages:

- Universal level detection for all liquids
- Adjustment and maintenance-free

**Food processing industry**

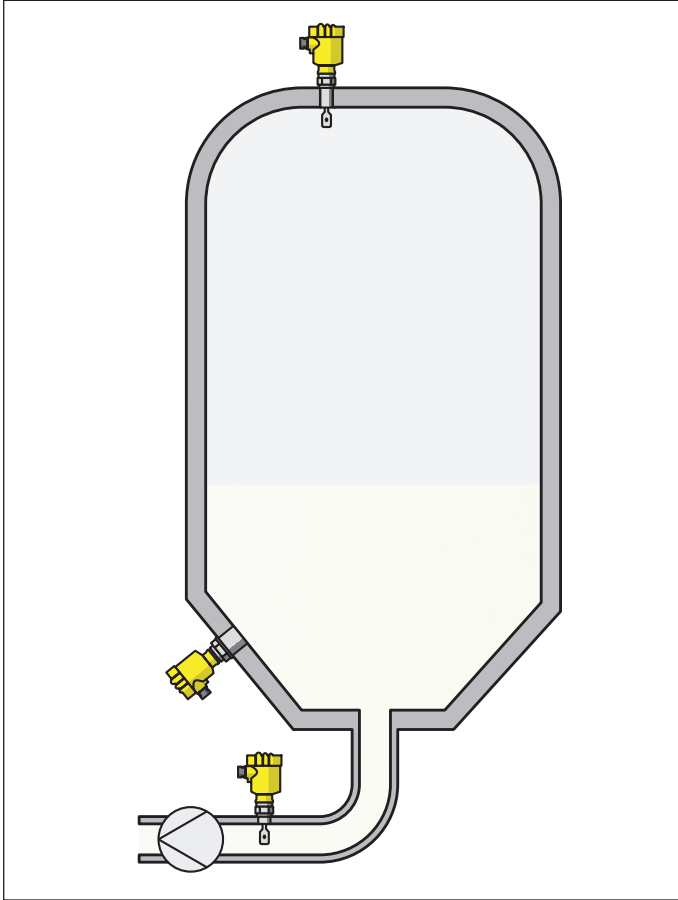

Fig. 6: Level detection and dry run protection in a tank storing milk

The processes in food processing tanks, e.g. for milk, place heavy demands on the installed measurement technology. High pressures and temperatures are generated during sterilization and cleaning of the tanks. That means that the implemented level measuring instruments and level detectors must meet the requirements of hygienic design. The innocuousness of all wetted materials must be proven and optimum cleanability must be ensured through hygienic technical design.

VEGASWING is installed for level detection and as dry run protection system. The tuning fork is highly polished for use in sensitive foodstuffs such as milk.

Advantages:

- Universal level detection for all liquids
- High-resistance sensor materials such as PFA, ECTFE, Alloy C22 (2.4602), enamel
- Adjustment and maintenance-free

**Cryogenic processes**

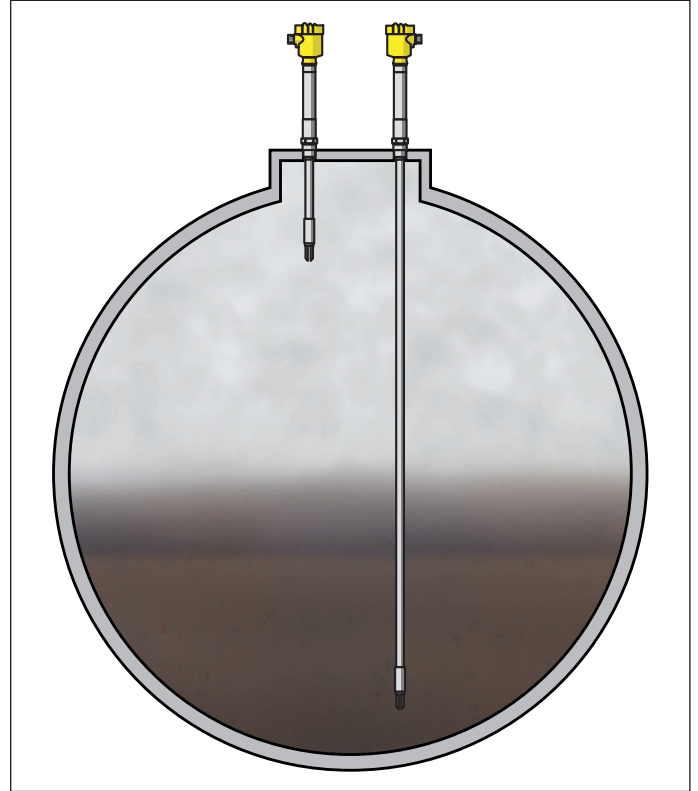

Fig. 7: Level detection in a liquid gas vessel

The extremely low temperatures in liquid tanks are a challenge for the installed measurement instrumentation. Petroleum gas is stored for example at  $-162\text{ °C}$  ( $-260\text{ °F}$ ) and nitrogen even at  $-196\text{ °C}$  ( $-321\text{ °F}$ ). The VEGASWING 66 with  $-196\text{ ... }+450\text{ °C}$  ( $-321\text{ ... }+482\text{ °F}$ ) can cover a large temperature range.

Advantages:

- Universal use, because only low min. density of the medium required.
- Double safety through Second Line of Defense
- Cost-optimized setup without medium

**Steam vessel**

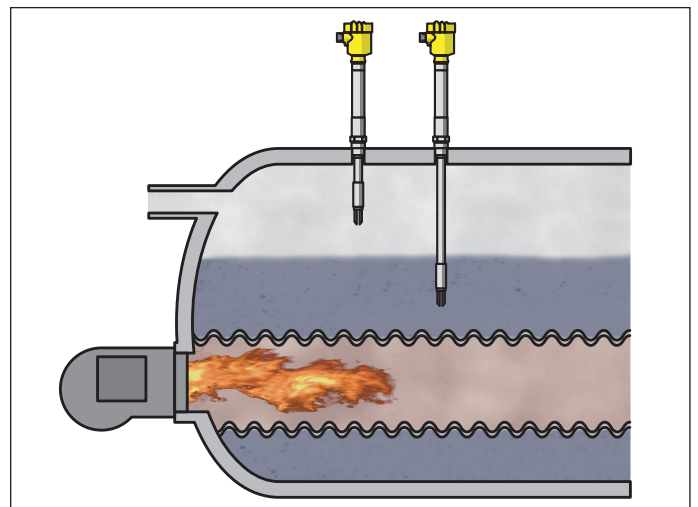

Fig. 8: Level detection in a steam boiler

Point level measurement in steam boilers monitors the high and low water level of the vessel. The point level measurement is independent of vessel pressure and temperature as well as the density of the water or the saturated steam. With its pressure range up to 160 bar (2320 psig) and a max. temperature up to  $+450\text{ °C}$  ( $+482\text{ °F}$ ), the VEGASWING 66

covers the majority of saturated steam applications.

Advantages:

- Reliable and quick function test
- Double safety through Second Line of Defense
- Flexible and high availability in applications up to SIL3

## 2 Type overview

VEGASWING 51



VEGASWING 53



VEGASWING 61



VEGASWING 63



VEGASWING 66



<b>Applications</b>	Point level measurement in liquids	Point level measurement in liquids	Point level measurement in liquids	Point level measurement in liquids	Point level measurement in liquids High and low process temperatures High process pressures
<b>Length</b>	-	100 ... 1000 mm (3.94 ... 39.37 in)	-	80 ... 6000 mm (3.15 ... 236.22 in)	260 ... 3000 mm (10.24 ... 118.11 in)
<b>Process fitting</b>	Thread G½, G¾, G1 Hygienic fittings	Thread G¾, G1 Hygienic fittings	Thread G¾, G1 Flanges Hygienic fittings	Thread G¾, G1 Flanges Hygienic fittings	Thread G1 Flanges
<b>Process temperature</b>	-40 ... +100 °C (-40 ... +212 °F) -40 ... +150 °C (-40 ... +302 °F) with temperature adapter	-40 ... +100 °C (-40 ... +212 °F) -40 ... +150 °C (-40 ... +302 °F) with temperature adapter	-50 ... +150 °C (-58 ... +302 °F) -50 ... +250 °C (-58 ... +482 °F) with temperature adapter	-50 ... +150 °C (-58 ... +302 °F) -50 ... +250 °C (-58 ... +482 °F) with temperature adapter	-196 ... +450 °C (-321 ... +482 °F)
<b>Process pressure</b>	-1 ... 64 bar (-14.5 ... 928 psig)	-1 ... 64 bar (-14.5 ... 928 psig)	-1 ... 64 bar (-14.5 ... 928 psig)	-1 ... 64 bar (-14.5 ... 928 psig)	-1 ... 160 bar (-14.5 ... 2321 psig)
<b>Signal output</b>	Transistor Contactless electronic switch IO-Link	Transistor Contactless electronic switch IO-Link	Relay Transistor Two-wire NAMUR Contactless electronic switch	Relay Transistor Two-wire NAMUR Contactless electronic switch	Relay Transistor Two-wire
<b>Ruggedness</b>	+	+	+	+	+
<b>Sensitivity</b>	+	+	++	++	++
<b>Buildup</b>	++	++	+	+	+
<b>Cleanability</b>	++	++	++	++	++
<b>Installation length</b>	++	++	++	++	++

### 3 Instrument selection

#### VEGASWING 51, 53

VEGASWING 51 is a universal level switch with small dimensions. Independent of the mounting position, it detects the level reliably and with millimetre accuracy. The instrument can be used for full or empty alarm, as approved overfill protection or dry run or pump protection in vessels and pipelines. VEGASWING 51 is an economical solution with a small, compact stainless steel housing and is available with the electronics versions transistor output, contactless electronic switch and IO-Link.

On VEGASWING 53, the switching point can be adapted to the process with a freely selectable extension tube.

#### VEGASWING 61, 63

VEGASWING series 60 level switches are instruments from the VEGA plics® series, which are available in standard and tube version. Thanks to the many different process fittings, housings and electronics versions, plics® instruments can be configured in versions suitable for any application. They have all standard approvals and the tuning fork can also be polished, e.g. for applications in the food processing industry.

On VEGASWING 63, the switching point can be adapted to the process with a freely selectable extension tube.

VEGASWING are virtually unaffected by product properties and thus do not have to be adjusted.

The level switches are used in applications with process temperatures up to +250 °C (+482 °F) and pressures of up to 64 bar (928 psig).

They detect liquids from 0.5 ... 2.5 g/cm<sup>3</sup> (0.018 ... 0.09 lbs/in<sup>3</sup>).

All electronics are qualified for the function "overfill and dry run protection" according to IEC 61508 and 61511 for SIL2, in redundant version also up to SIL3.

#### VEGASWING 66

The point level sensors VEGASWING 66 are instruments from the VEGA plics® series and available in standard and tube version. The instruments are suitable for liquids with extremely low and high process temperatures. With their many different process fittings, housings and electronics versions, plics® instruments can be ideally configured for any application. They have all standard approvals.

VEGASWING are virtually unaffected by product properties and thus do not have to be adjusted.

The level switches are used in applications with process temperatures up to -196 ... +450 °C (-321 ... +482 °F) and pressures of up to 160 bar (2321 psig).

They detect liquids from 0.42 to 2.5 g/cm<sup>3</sup> (0.015 to 0.09 lbs/in<sup>3</sup>).

All electronics are qualified for the function "overfill and dry run protection" according to IEC 61508 and 61511 for SIL2, in homogeneous redundant version also up to SIL3.



## 4 Instrument features

### Second Line of Defense

To increase safety in applications with dangerous or toxic products, the series 60 sensors can be ordered with a welded, gas-tight feedthrough (Second Line of Defense).

### Temperature adapter

For VEGASWING 61 and 63, a temperature adapter is optionally available. With it you can increase the max. permissible process temperature from +150 °C (+302 °F) to +250 °C (+482 °F).

### SIL qualification

As an option, the sensors of VEGASWING series 60 can be ordered with SIL qualification. The sensors can thus be used in applications according to SIL2. In a homogeneously redundant configuration, they can also be used up to SIL3.

### Coating

To make the use of VEGASWING series 60 sensors possible in aggressive or corrosive products, different coatings are optionally available. The following coating materials can be used depending on the required resistance. Our application engineers will be pleased to give you advice on resistances and the possibilities the sensors offer.

- ECTFE
- PFA
- Enamel

## 5 Accessories

### Protective cover

To protect the sensor against pollution and strong heat due to the sun, you can snap a weather protective cover onto the sensor housing.

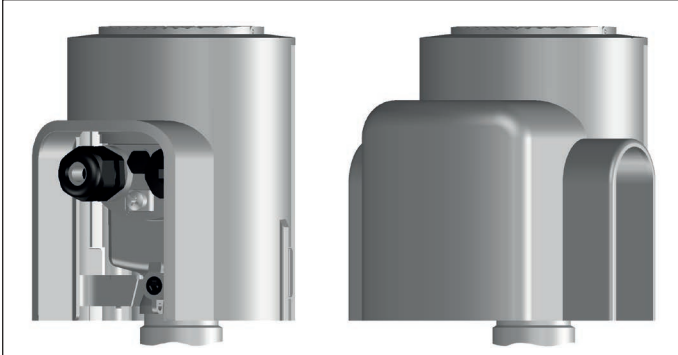

Fig. 9: Weather protection cover in different versions

### Display module PLICSLED

The display module allows you to clearly display the switching status of the sensor. For this purpose, housing lids with inspection windows in different materials are available. The plastic housing is optionally available with a transparent lid through which you can see the indicator lamp from the side.

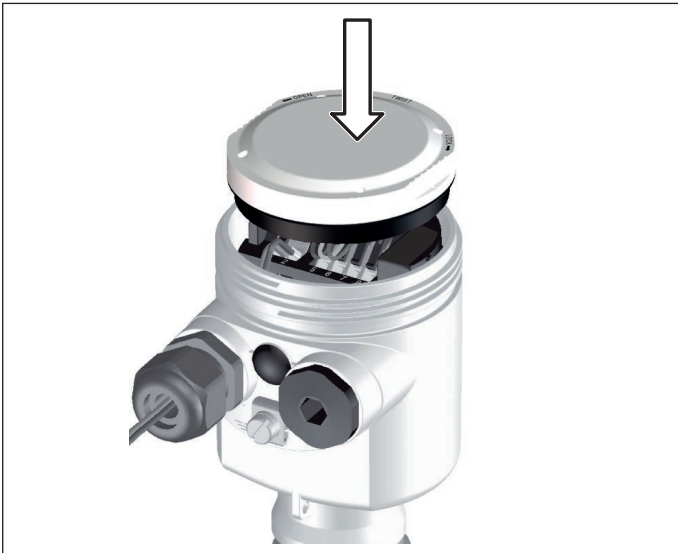

Fig. 10: Display module PLICSLED

### Lock fitting

VEGASWING in tube version can be mounted with a lock fitting for infinitely variable height adjustment. Take note of the pressure specifications of the lock fitting.

Keep in mind that the lock fitting must not be used with coated instrument versions.



Fig. 11: Lock fitting - e.g. ARV-SG63.3 for VEGASWING 63 up to 64 bar

### Plug connector

Instead of a cable gland, you can also use various plug connectors for making connections. The following plug connectors are available for VEGASWING series 60:

- ISO 4400
- ISO 4400 with Quick-On fitting
- Amphenol-Tuchel
- Harting HAN 7D
- Harting HAN 8D
- M12 x 1



Fig. 12: Plug connector - e.g. VEGASWING series 60 with ISO 4400 plug

There are no cable glands possible for the VEGASWING of series 50. The instruments are available with the following plug connectors:

- ISO 4400
- ISO 4400 with Quick-On fitting
- M12 x 1

## 6 Selection criteria



Version		VEGASWING		VEGASWING		VEGASWING 66	
		51 Compact	53 Tube	61 Compact	63 Tube	66 Compact	66 Tube
Vessel	Probe length max. 3 m	-	●	-	●	-	●
	Probe length max. 6 m	-	●	-	●	-	-
	Cryogenic applications	-	-	-	-	●	●
	Pipelines	●	●	●	●	●	●
Process	Aggressive liquids	○	○	○	○	○	○
	Bubble or foam generation	●	●	●	●	●	●
	Wave movements at the surface	●	●	●	●	●	●
	Steam or condensation	●	●	●	●	●	●
	Buildup	○	○	○	○	○	○
	Changing density	●	●	●	●	●	●
	Temperatures up to +150 °C	●	●	●	●	●	●
	Temperatures up to +250 °C	-	-	●	●	●	●
	Temperatures > +250 °C	-	-	-	-	●	●
	Pressures up to 64 bar	●	●	●	●	●	●
	Pressures up to 160 bar	-	-	-	-	●	●
	Hygienic applications	○	○	●	●	-	-
	Narrow space above the vessel	●	●	●	●	-	-
	Steam boiler application	-	-	-	-	●	●
Process fitting	Threaded fittings	●	●	●	●	●	●
	Flange connections	-	-	●	●	●	●
	Hygienic fittings	●	●	●	●	-	-
Sensor	Stainless steel	●	●	●	●	●	●
	Coating	-	-	●	●	-	-
	Polished version	●	●	●	●	-	-
	SIL qualification	-	-	●	●	●	●
Industry	Chemical	●	●	●	●	●	●
	Power generation	○	○	○	○	●	●
	Foodstuffs	○	○	●	●	-	-
	Offshore	●	●	○	○	●	●
	Petrochemical	○	○	○	○	●	●
	Pharmaceutical	○	○	●	●	-	-
	Shipbuilding	●	●	●	○	●	○
	Environment and recycling industry	●	●	●	●	●	●
	Water	●	●	●	●	○	○
Waste water	○	○	○	○	○	○	

- = optimum suitability
- = possible with limitations
- = not recommended

## 7 Housing overview - VEGASWING 61, 63, 66

<b>Plastic PBT</b>	
<b>Protection rating</b>	IP66/IP67
<b>Version</b>	Single chamber
<b>Application area</b>	Industrial environment

<b>Aluminium</b>	
<b>Protection rating</b>	IP66/IP67, IP66/IP68 (1 bar)
<b>Version</b>	Single chamber
<b>Application area</b>	Industrial environment with increased mechanical stress

<b>Stainless steel 316L</b>		
<b>Protection rating</b>	IP66/IP67	IP66/IP67, IP66/IP68 (1 bar)
<b>Version</b>	Single chamber, electropolished	Single chamber, precision casting
<b>Application area</b>	Aggressive environment, food processing, pharmaceutical	Aggressive environment, extreme mechanical stress

## 8 Mounting

### Switching point

In general, VEGASWING can be installed in any position. The instrument only has to be mounted in such a way that the vibrating element is at the height of the desired switching point.

The tuning fork has lateral markings (notches) marking the switching point with vertical installation. The switching point refers to the medium water with basic setting of the density switch  $\geq 0.7 \text{ g/cm}^3$  (0.025 lbs/in<sup>3</sup>). Keep in mind that foams with a density  $> 0.45 \text{ g/cm}^3$  (0.016 lbs/in<sup>3</sup>) are detected by the sensor.

### Nozzle

The vibrating element should protrude into the vessel to avoid buildup. For that reason, avoid using mounting bosses for flanges and screwed fittings. This applies particularly to horizontal installation and use with adhesive products.

### Agitators

Due to agitators, vibration or similar, the level switch can be subjected to strong lateral forces. For this reason, do not use an overly long extension tube for VEGASWING 63 or 66, but check if a VEGASWING 51 or 61 level switch without tube extension couldn't be used instead, mounted on the side of the vessel in horizontal position.

Extreme vibration caused by the process or the equipment, e.g. agitators or turbulence in the vessel, can cause the extension tube of VEGASWING to vibrate in resonance. This leads to increased stress on the upper weld joint. Should a longer tube version be required, you can provide a suitable support or guy directly above the vibrating element to secure the extension tube.



This measure applies mainly to applications in Ex areas. Make sure that the tube is not subject to bending stress due to this measure.

### Inflowing medium

If VEGASWING is mounted in the filling stream, unwanted false measurement signals can be generated. For this reason, mount VEGASWING at a position in the vessel where no disturbances, e.g. from filling openings, agitators, etc., can occur.

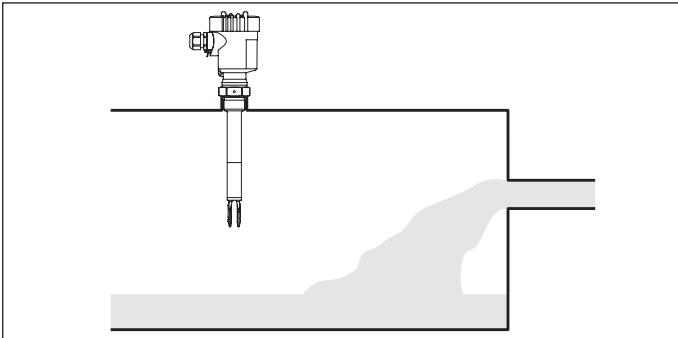

Fig. 13: Inflowing medium

### Product flow

To make sure the tuning fork of VEGASWING generates as little resistance as possible to product flow, mount the sensor so that the surfaces are parallel to the product movement.

### Lock fitting

VEGASWING in tube version can be mounted with a lock fitting for infinitely variable height adjustment. Take note of the pressure specifications of the lock fitting.

Keep in mind that the lock fitting must not be used with coated instrument versions.

### Pressure/Vacuum

The process fitting must be sealed if there is gauge or low pressure in the vessel. Check if the sealing material is resistant against the measured product and the process temperature.

### Protective cover

To protect the sensor against pollution and strong heat due to the sun, you can snap a weather protective cover onto the sensor housing.

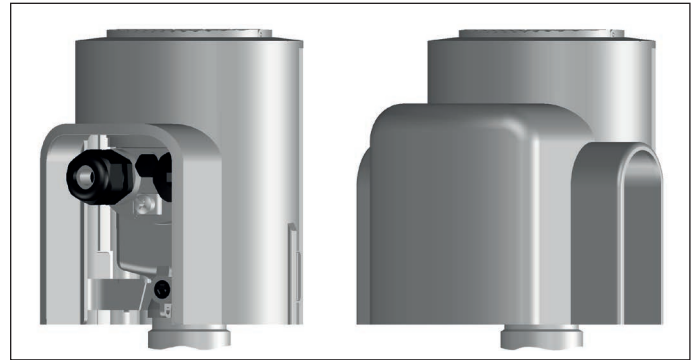

Fig. 14: Weather protection cover in different versions

## 9 Electronics - relay output

### Preparing the connection

#### Note safety instructions

Always keep in mind the following safety instructions:

- Connect only in the complete absence of line voltage

#### Take note of safety instructions for Ex applications

In hazardous areas you must take note of the respective regulations, conformity and type approval certificates of the sensors and power supply units.

#### Select voltage supply

Connect the operating voltage according to the following diagrams. The oscillator with relay output is designed in protection class 1. To maintain this protection class, it is absolutely necessary that the ground conductor be connected to the internal ground terminal. Take note of the general installation regulations. As a rule, connect VEGASWING to vessel ground (PA), or in case of plastic vessels, to the next ground potential. On the side of the housing there is a ground terminal between the cable entries. This connection serves to drain off electrostatic charges. In Ex applications, the installation regulations for hazardous areas must be given priority.

#### Select connection cable

The VEGASWING is connected with standard three-wire cable without shield with round cross-section. If electromagnetic interference is expected which is above the test values of EN 61326 for industrial areas, shielded cable should be used.

Use a suitable cable gland and select a suitable seal depending on the cable diameter.



In hazardous areas, use only approved cable connections for VEGASWING.

#### Select connection cable for Ex applications

Take note of the corresponding installation regulations for Ex applications.

### VEGASWING 61, 63

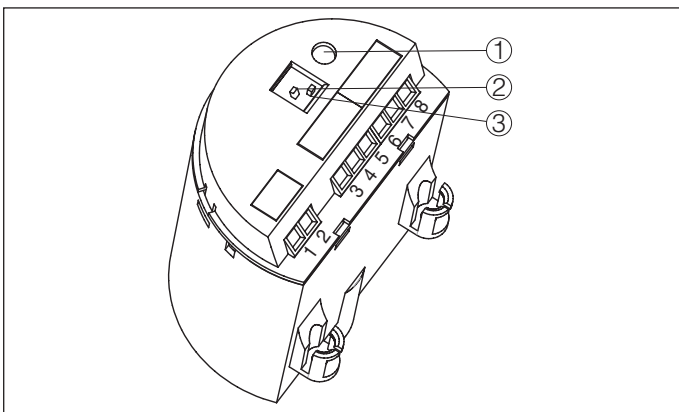

Fig. 15: VEGASWING 61, 63 - electronics module with relay output

- 1 Control lamp
- 2 DIL switch for mode adjustment
- 3 DIL switch for sensitivity adjustment

We recommend connecting VEGASWING in such a way that the switching circuit is open when there is a level signal, line break or failure (safe state).

The relays are always shown in non-operative condition.

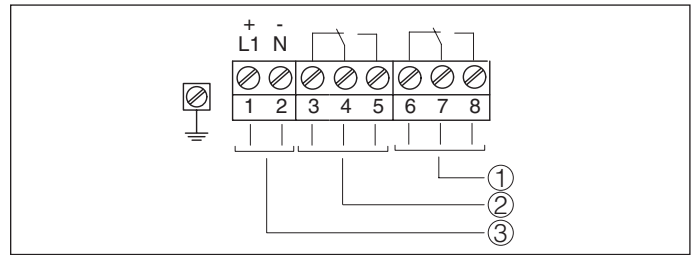

Fig. 16: VEGASWING 61, 63 - wiring plan - relay output

- 1 Relay output
- 2 Relay output
- 3 Voltage supply

### VEGASWING 66

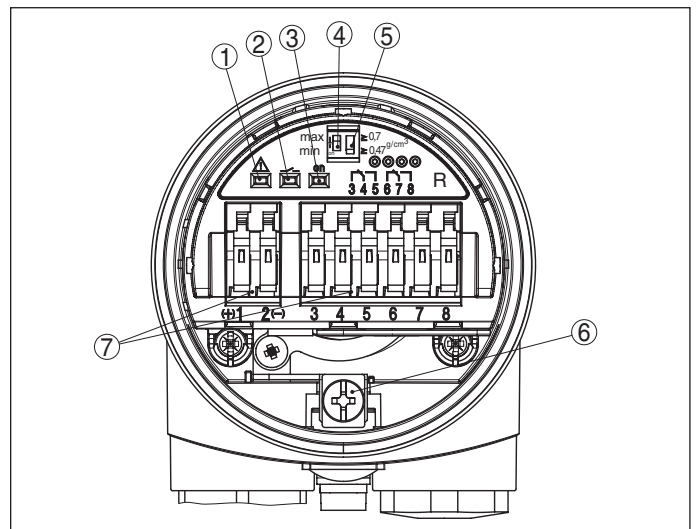

Fig. 17: Electronics and connection compartment, single chamber housing

- 1 Control lamp - fault indication (red)
- 2 Control lamp - Switching status (yellow)
- 3 Control lamp - Operating status (green)
- 4 Mode switch for selecting the switching behaviour (min./max.)
- 5 DIL switch for sensitivity adjustment
- 6 Ground terminal
- 7 Connection terminals

We recommend connecting VEGASWING in such a way that the switching circuit is open when there is a level signal, line break or failure (safe state).

The relays are always shown in non-operative condition.

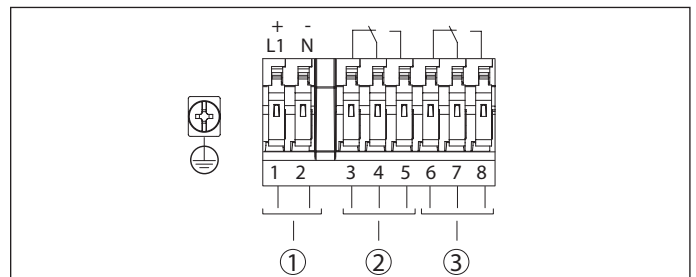

Fig. 18: Wiring plan, single chamber housing

- 1 Voltage supply
- 2 Relay output SPDT
- 3 Relay output SPDT

## 10 Electronics - transistor output

### Preparing the connection

#### Note safety instructions

Always keep in mind the following safety instructions:

- Connect only in the complete absence of line voltage

#### Take note of safety instructions for Ex applications

In hazardous areas you must take note of the respective regulations, conformity and type approval certificates of the sensors and power supply units.

#### Select voltage supply

Connect the voltage supply according to the following diagrams. Take note of the general installation regulations. As a rule, connect VEGASWING to vessel ground (PA), or in case of plastic vessels, to the next ground potential. On the side of the instrument housing there is a ground terminal between the cable entries. This connection serves to drain off electrostatic charges. In Ex applications, the installation regulations for hazardous areas must be given priority.

#### Select connection cable

The VEGASWING is connected with standard two-wire cable without shield with round cross-section. If electromagnetic interference is expected which is above the test values of EN 61326 for industrial areas, shielded cable should be used.

Use a suitable cable gland and select a suitable seal depending on the cable diameter.



In hazardous areas, use only approved cable connections for VEGASWING.

#### Select connection cable for Ex applications

Take note of the corresponding installation regulations for Ex applications.

#### Transistor output

We recommend connecting VEGASWING in such a way that the switching circuit is open when there is a level signal, line break or failure (safe state).

The instrument is used to control relays, contactors, magnet valves, warning lights, horns as well as PLC inputs.

### VEGASWING 61, 63

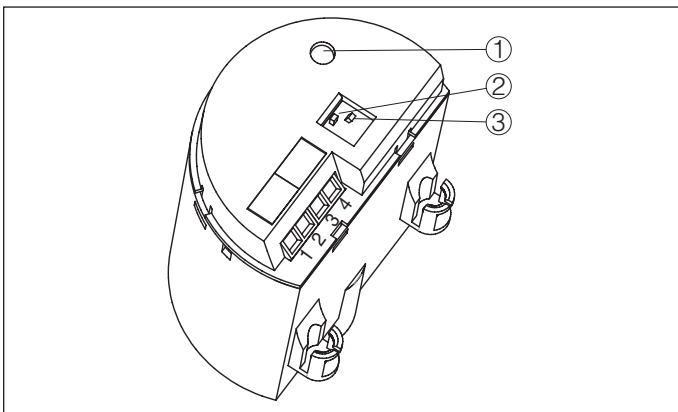

Fig. 19: VEGASWING 61, 63 - electronics module with transistor output

- 1 Control lamp
- 2 DIL switch for mode adjustment
- 3 DIL switch for sensitivity adjustment

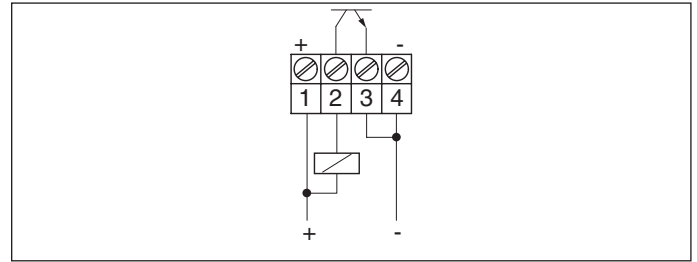

Fig. 20: VEGASWING 61, 63 - transistor output - NPN action

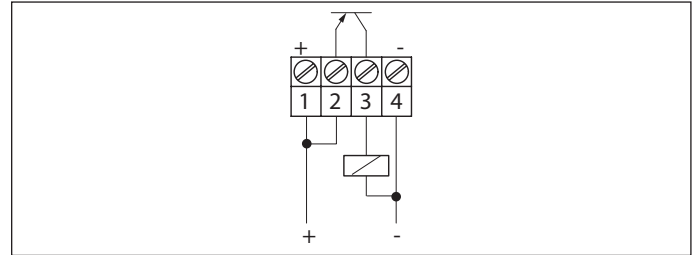

Fig. 21: VEGASWING 61, 63 - transistor output - PNP action

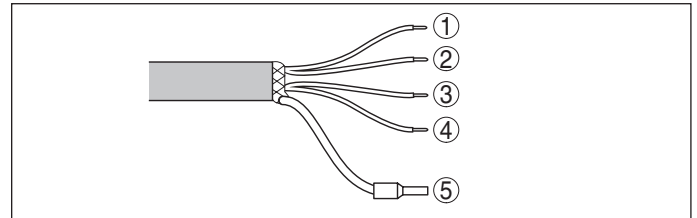

Fig. 22: Wire assignment connection cable. The numbers of the wires correspond to the terminals of the instrument.

- 1 brown (+) voltage supply
- 2 White
- 3 Yellow
- 4 blue (-) voltage supply
- 5 Shielding

### VEGASWING 66

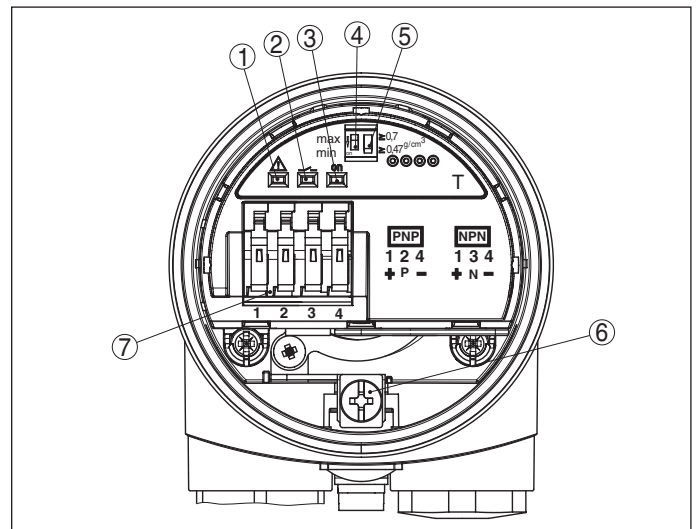

Fig. 23: VEGASWING 66 - electronics module with transistor output

- 1 Control lamp - fault indication (red)
- 2 Control lamp - Switching status (yellow)
- 3 Control lamp - Operating status (green)
- 4 Mode switch for selecting the switching behaviour (min./max.)
- 5 DIL switch for sensitivity adjustment
- 6 Ground terminal
- 7 Connection terminals

We recommend connecting VEGASWING according to the closed-circuit principle, i.e. the switching circuit is open when there is a level signal, line break or fault (safe state).

The instrument is used to control relays, contactors, magnet valves, warning lights, horns as well as PLC inputs.

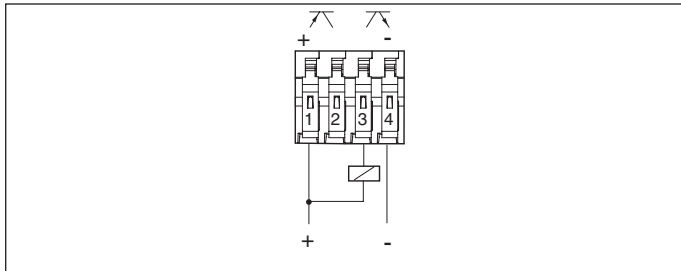

Fig. 24: VEGASWING 66 - transistor output - NPN action

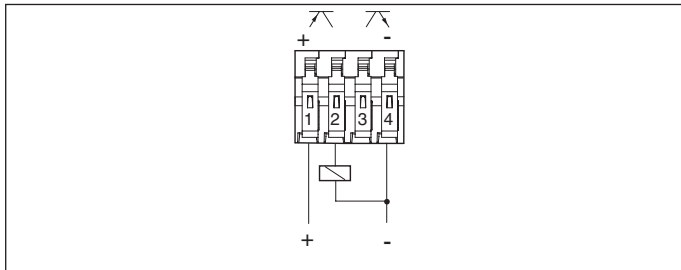

Fig. 25: VEGASWING 66 - transistor output - PNP action

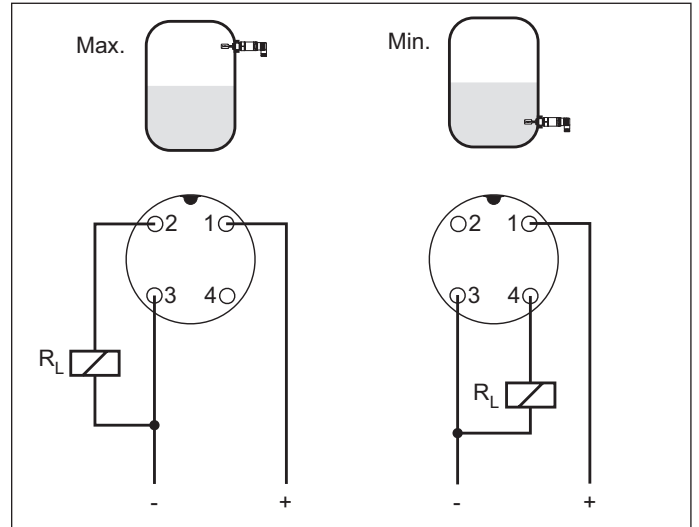

Fig. 27: VEGASWING 51, 53 - transistor output with M12 x 1 plug connection (housing)

- 1 Brown
- 2 White
- 3 Blue
- 4 Black
- RL Load resistance (contactor, relay, etc.)

**VEGASWING 51, 53**

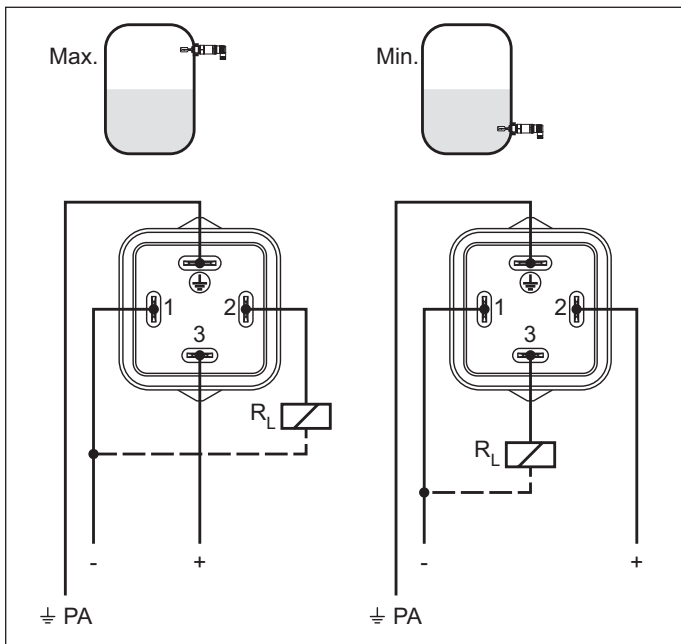

Fig. 26: VEGASWING 51, 53 - transistor output with valve plug ISO 4400

- PA Potential equalisation
- RL Load resistance (contactor, relay, etc.)



## 11 Electronics - contactless electronic switch

### Preparing the connection

#### Note safety instructions

Always keep in mind the following safety instructions:

- Connect only in the complete absence of line voltage

#### Take note of safety instructions for Ex applications

In hazardous areas you must take note of the respective regulations, conformity and type approval certificates of the sensors and power supply units.

#### Select voltage supply

Connect the operating voltage according to the following diagrams. The electronics module is designed in protection class 1. To maintain this protection class, it is absolutely necessary that the ground conductor be connected to the internal ground terminal. Take note of the general installation regulations. As a rule, connect VEGASWING to vessel ground (PA), or in case of plastic vessels, to the next ground potential. On the side of the housing there is a ground terminal between the cable entries. This connection serves to drain off electrostatic charges. In Ex applications, the installation regulations for hazardous areas must be given priority.

#### Select connection cable

The VEGASWING is connected with standard three-wire cable without shield with round cross-section. If electromagnetic interference is expected which is above the test values of EN 61326 for industrial areas, shielded cable should be used.

Use a suitable cable gland and select a suitable seal depending on the cable diameter.



In hazardous areas, use only approved cable connections for VEGASWING.

#### Select connection cable for Ex applications

Take note of the corresponding installation regulations for Ex applications.

#### Contactless electronic switch

We recommend connecting VEGASWING in such a way that the switching circuit is open when there is a level signal, line break or failure (safe state).

The contactless electronic switch is always shown in non-operative condition.

The instrument is used for direct control of relays, contactors, magnet valves, warning lights, horns etc. It must not be operated without an intermediately connected load, because the electronics would be destroyed if connected directly to the mains. It is not suitable for connection to low voltage PLC inputs.

Domestic current is temporarily lowered below 1 mA after switching off the load so that contactors, whose holding current is lower than the constant domestic current of the electronics, are reliably switched off.

When VEGASWING is used as part of an overfill protection system according to WHG, also note the regulations of the general type approval.

### VEGASWING 61, 63

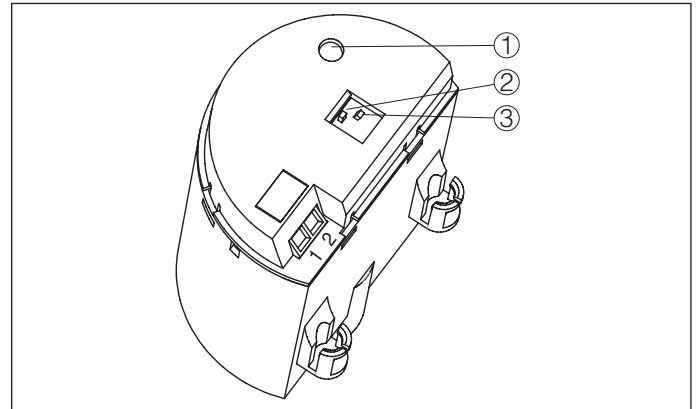

Fig. 28: VEGASWING 61, 63 - electronics module with contactless electronic switch

- 1 Control lamp
- 2 DIL switch for mode adjustment
- 3 DIL switch for sensitivity adjustment

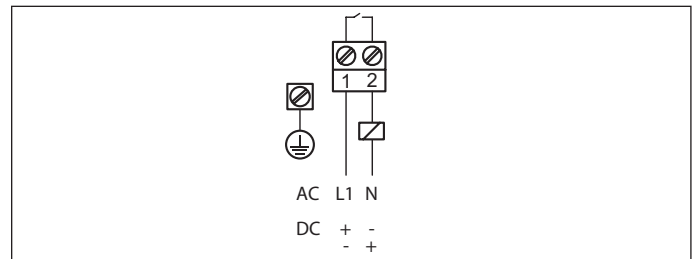

Fig. 29: VEGASWING 61, 63 - wiring plan - output, contactless electronic switch

### VEGASWING 51, 53

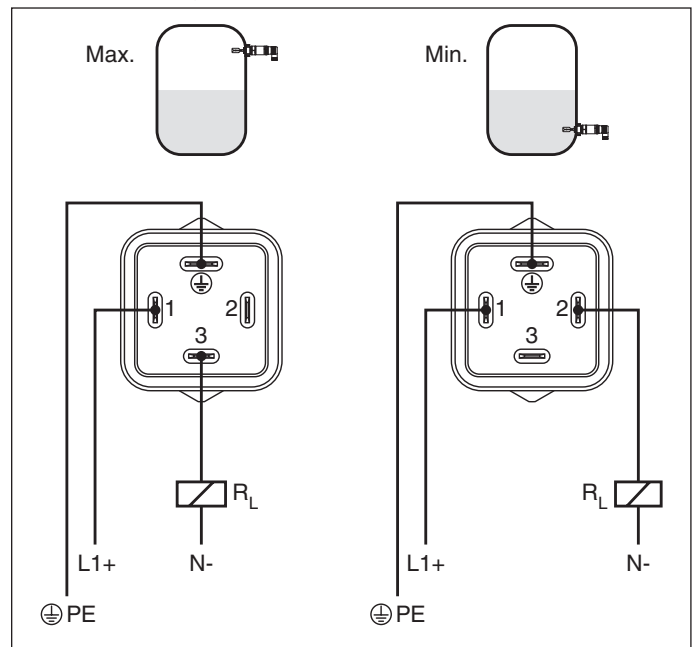

Fig. 30: VEGASWING 51, 53 - contactless electronic switch with valve plug ISO 4400

- PE Protection earth  
 RL Load resistance (contactor, relay, etc.)

## 12 Electronics - two-wire output 8/16 mA

### Preparing the connection

#### Note safety instructions

Always keep in mind the following safety instructions:

- Connect only in the complete absence of line voltage

#### Take note of safety instructions for Ex applications

In hazardous areas you must take note of the respective regulations, conformity and type approval certificates of the sensors and power supply units.

#### Select voltage supply

Connect the voltage supply according to the following diagrams. Take note of the general installation regulations. As a rule, connect VEGASWING to vessel ground (PA), or in case of plastic vessels, to the next ground potential. On the side of the instrument housing there is a ground terminal between the cable entries. This connection serves to drain off electrostatic charges. In Ex applications, the installation regulations for hazardous areas must be given priority.

#### Select connection cable

The VEGASWING is connected with standard two-wire cable without shield with round cross-section. If electromagnetic interference is expected which is above the test values of EN 61326 for industrial areas, shielded cable should be used.

Use a suitable cable gland and select a suitable seal depending on the cable diameter.



In hazardous areas, use only approved cable connections for VEGASWING.

#### Select connection cable for Ex applications

Take note of the corresponding installation regulations for Ex applications.

### Two-wire output

#### VEGASWING 61, 63

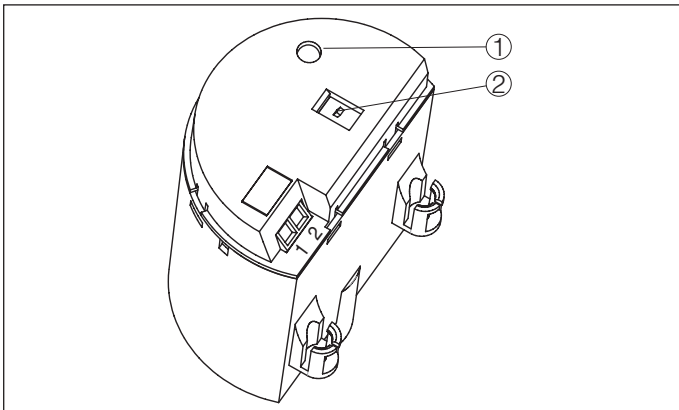

Fig. 31: VEGASWING 61, 63 - electronics module with two-wire electronics

- 1 Control lamp
- 2 DIL switch for sensitivity adjustment

We recommend connecting VEGASWING in such a way that the switching circuit is open when there is a level signal, line break or failure (safe state).

For connection to a controller, ditto Ex operating voltage via the connected controller.

The wiring example is applicable for all suitable controllers.

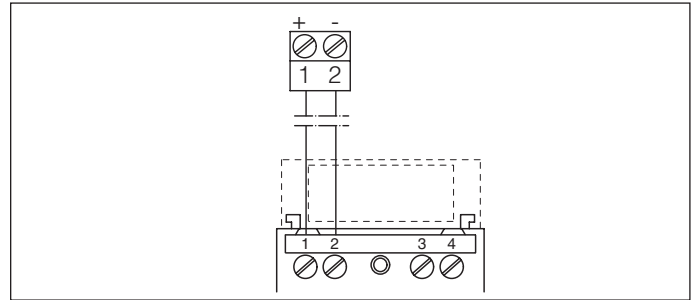

Fig. 32: VEGASWING 61, 63 - wiring plan - two-wire output

#### VEGASWING 66

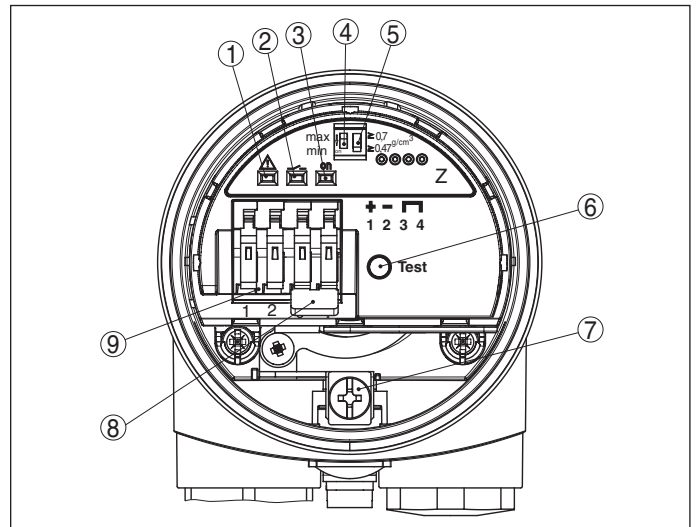

Fig. 33: VEGASWING 66 - electronics module with two-wire electronics

- 1 Control lamp - fault indication (red)
- 2 Control lamp - Switching status (yellow)
- 3 Control lamp - Operating status (green)
- 4 Mode switch for selecting the switching behaviour (min./max.)
- 5 DIL switch for sensitivity adjustment
- 6 Test key
- 7 Ground terminal
- 8 Connector block
- 9 Connection terminals

We recommend connecting VEGASWING in such a way that the switching circuit is open when there is a level signal, line break or failure (safe state).

For connection to a controller, ditto Ex operating voltage via the connected controller.

The wiring example is applicable for all suitable controllers.

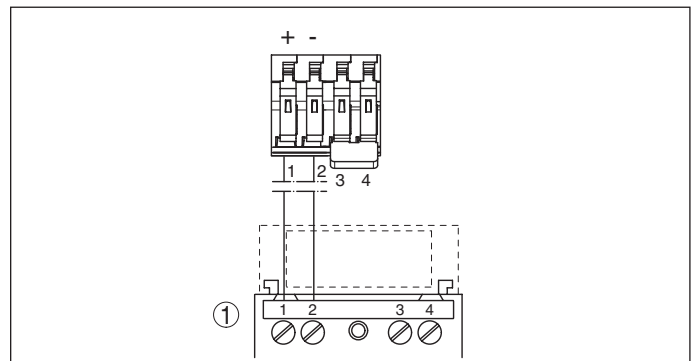

Fig. 34: VEGASWING 66 - wiring plan - two-wire output

- 1 Controller

### 13 Electronics - NAMUR output

#### Preparing the connection

##### Note safety instructions

Always keep in mind the following safety instructions:

- Connect only in the complete absence of line voltage

##### Take note of safety instructions for Ex applications

In hazardous areas you must take note of the respective regulations, conformity and type approval certificates of the sensors and power supply units.

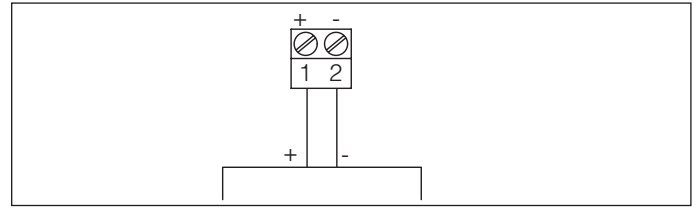

Fig. 36: Wiring plan - NAMUR output

##### Select voltage supply

Connect the voltage supply according to the following diagrams. Take note of the general installation regulations. As a rule, connect VEGASWING to vessel ground (PA), or in case of plastic vessels, to the next ground potential. On the side of the instrument housing there is a ground terminal between the cable entries. This connection serves to drain off electrostatic charges. In Ex applications, the installation regulations for hazardous areas must be given priority.

##### Select connection cable

The VEGASWING is connected with standard two-wire cable without shield with round cross-section. If electromagnetic interference is expected which is above the test values of EN 61326 for industrial areas, shielded cable should be used.

Use a suitable cable gland and select a suitable seal depending on the cable diameter.



In hazardous areas, use only approved cable connections for VEGASWING.

##### Select connection cable for Ex applications

Take note of the corresponding installation regulations for Ex applications.

#### NAMUR output

##### VEGASWING 61, 63

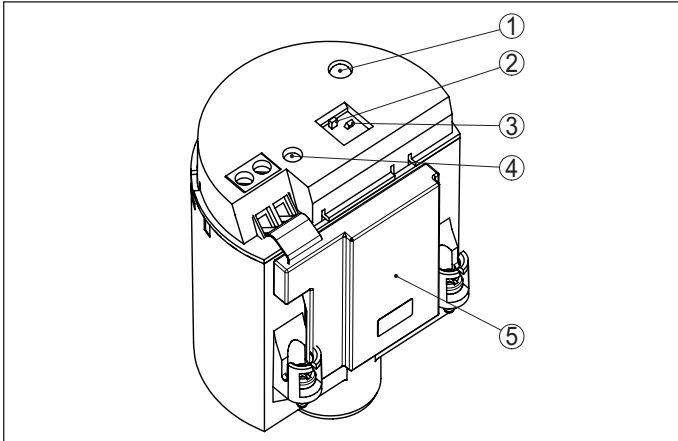

Fig. 35: VEGASWING 61, 63 - electronics module with NAMUR electronics

- 1 Control lamp
- 2 DIL switch for characteristics reversal
- 3 DIL switch for sensitivity adjustment
- 4 Simulation key
- 5 EMC filter element

For connection to an amplifier according to NAMUR (IEC 60947-5-6, EN 50227).

## 14 IO-Link output

### Preparing the connection

#### Note safety instructions

Always keep in mind the following safety instructions:

- Connect only in the complete absence of line voltage.
- The electrical connection must only be carried out by trained, qualified personnel authorised by the plant operator.
- Always switch off power supply, before connecting or disconnecting the instrument.

#### Select voltage supply

Connect the power supply according to the following wiring diagrams. Observe the general installation instructions.

#### Select connection cable

The instrument is connected with standard three-wire cable without shielding. If electromagnetic interference is expected which is above the test values of EN 61326 for industrial areas, shielded cable should be used.

Make sure that the cable used has the required temperature resistance and fire safety for max. occurring ambient temperature

#### Plug versions

#### M12 x 1 plug connection

This plug connection requires a prefabricated cable with plug. Depending on the version, protection IP66/IP67 or IP68 (0.2 bar).

#### IO-Link output

#### VEGASWING 51, 53

For connection to binary inputs of a PLC.

For power supply, use an energy-limited circuit according to EN 61010.

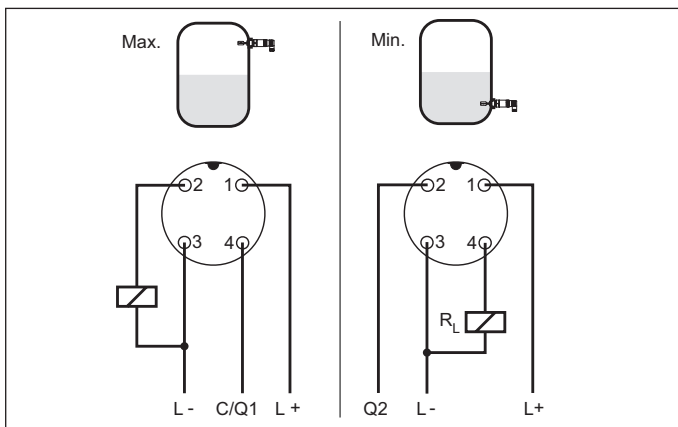

Fig. 37: Wiring plan (housing), terminal assignment IO-link output with M12 x 1 plug connection

- 1 L+ Voltage supply (brown)
  - 2 Max. level detection (white)
  - 3 L- Voltage supply (blue)
  - 4 Min. level detection/IO-Link communication (black)
- $R_L$  Load resistance (contactor, relay, etc.)

## 15 Adjustment

### 15.1 VEGASWING 51, 53

#### Switching point adaptation

Products with a density  $> 0.7 \dots 2.5 \text{ g/cm}^3$  ( $0.025 \dots 0.09 \text{ lbs/in}^3$ ) can be detected. This setting cannot be modified.

The switching status of VEGASWING can be checked when the housing is closed (signal lamp, illuminated ring below the plug).

#### Simulation

VEGASWING has an integrated test switch which can be activated magnetically. To test the instrument, you have to hold the test magnet (accessory) to the magnet symbol on the instrument housing.

The test magnet changes the current switching condition of the instrument. You can check the change on the signal lamp. Please note that the connected instruments are activated during the test.

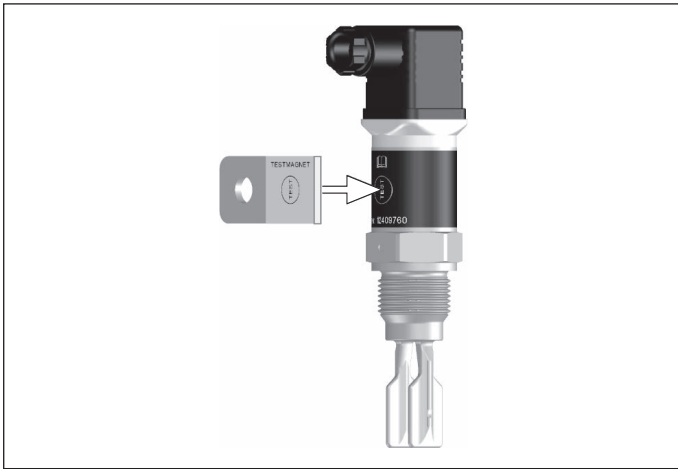

Fig. 38: Simulation of the output signal

#### Mode adjustment

Due to the respective polarisation of the operating voltage, the switching behaviour can be defined (max. detection/min. detection). by different connection of the consumer (load) PNP or NPN behaviour can be reached for the version with transistor output.

#### Control lamp (LED)

The switching status of VEGASWING is visible from outside (control lamp, illuminated lens below the plug).

### 15.2 VEGASWING 61, 63

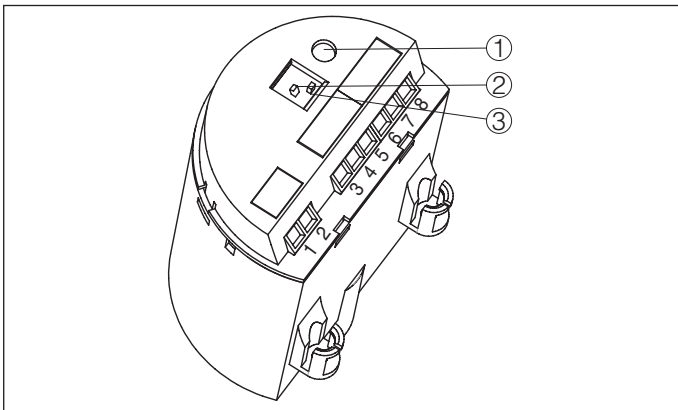

Fig. 39: Oscillator SWE60R - Relay output

- 1 Control lamp (LED)
- 2 DIL switch for mode adjustment
- 3 DIL switch for sensitivity adjustment

#### Switching point adaptation

With this DIL switch (3) you can set the switching point to liquids having a density between  $0.5$  and  $0.7 \text{ g/cm}^3$  ( $0.018$  and  $0.025 \text{ lbs/in}^3$ ). With the basic setting, liquids with a density of  $\geq 0.7 \text{ g/cm}^3$  ( $0.025 \text{ lbs/in}^3$ ) can be detected. In liquids with lower density, you must set the switch to  $\geq 0.5 \text{ g/cm}^3$  ( $0.018 \text{ lbs/in}^3$ ). The specifications for the position of the switching point relate to water - density value  $1 \text{ g/cm}^3$  ( $0.036 \text{ lbs/in}^3$ ). In products with a different density, the switching point will shift in the direction of the housing or tuning fork end depending on the density and type of installation.

#### Mode adjustment

With the mode adjustment (min./max.) you can change the switching condition of the output. You can set the required mode (A/max. - max. detection or overflow protection, B/min. - min. detection or dry run protection).

#### Control lamp (LED)

Diode for indication of the switching status (with plastic housing visible from outside).

### VEGASWING 61, 63 - NAMUR electronics

#### Simulation key

The simulation key is located in a recess on the upper side of the electronics module. Push the simulation key with a suitable object (screwdriver, pen, etc.).

When the key is pushed, a line break between sensor and processing unit is simulated. The signal lamp on the sensor extinguishes. The measuring system must signal a fault and take on a safe state when the key is pushed.

Keep in mind that downstream connected instruments will be activated during operation. This allows you to check the correct function of the measuring system.

#### Characteristics reversal

The characteristics of the NAMUR electronics can be reversed with the DIL switch. You can choose between falling characteristic curve (switch position max.) and rising characteristic curve (switch position min.). This allows you to output the desired current.

#### Modes

- min. - rising characteristic curve (High current when immersed)
- max. - falling characteristics (Low current when immersed)

The NAMUR output can be switched to falling or rising characteristics.

For applications according to WHG, the DIL switch must be set to position max.

### 15.3 VEGASWING 66

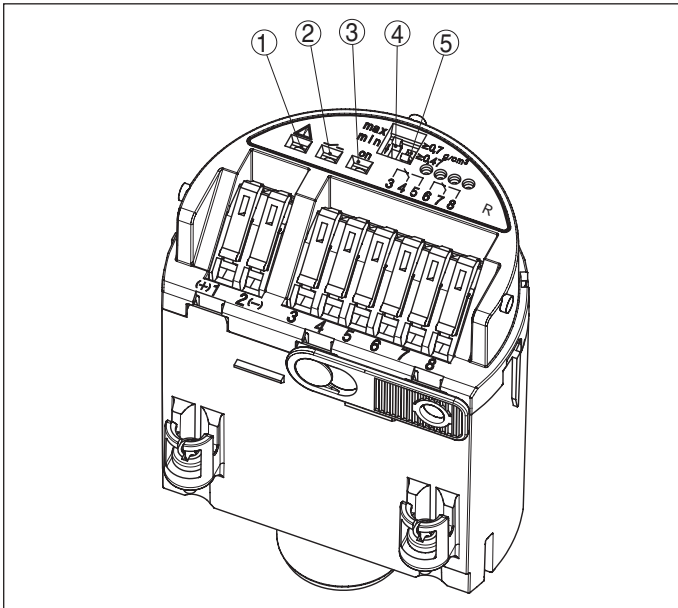

Fig. 40: Electronics module - VEGASWING 66, e.g. relay output

- 1 Control lamp for fault indication (red)
- 2 Control lamp for indication of the switching status (yellow)
- 3 Signal lamp for indication of the operating status (green)
- 4 Mode switch for selecting the switching behaviour (min./max.)
- 5 DIL switch for sensitivity adjustment

#### Switching point adaptation

With this DIL switch (3) you can set the switching point to liquids having a density between  $0.47 \text{ g/cm}^3$  ( $0.017 \text{ lbs/in}^3$ ) and  $0.7 \text{ g/cm}^3$  ( $0.025 \text{ lbs/in}^3$ ). With the basic setting, liquids with a density of  $\geq 0.7 \text{ g/cm}^3$  ( $0.025 \text{ lbs/in}^3$ ) can be detected. In liquids with lower density, you must set the switch to  $\geq 0.47 \text{ g/cm}^3$  ( $0.017 \text{ lbs/in}^3$ ). The specifications for the position of the switching point relate to water - density value  $1 \text{ g/cm}^3$  ( $0.036 \text{ lbs/in}^3$ ). In products with a different density, the switching point will shift in the direction of the housing or tuning fork end depending on the density and type of installation.

Optionally the instrument can be also delivered with a min. density range of  $\geq 0.42 \text{ g/cm}^3$  ( $0.015 \text{ lbs/in}^3$ ). In this case, the max. permissible process pressure is limited to 25 bar (363 psig). This instrument version may not be used in safety-instrumented systems (SIL) or in applications according to WHG.

#### Mode adjustment

With the mode adjustment (min./max.) you can change the switching condition of the output. You can set the required mode (A/max. - max. detection or overflow protection, B/min. - min. detection or dry run protection).

#### Control lamp (LED)

Diode for indication of the switching status (with plastic housing visible from outside).

## 16 Dimensions

### VEGASWING 51, standard version, thread

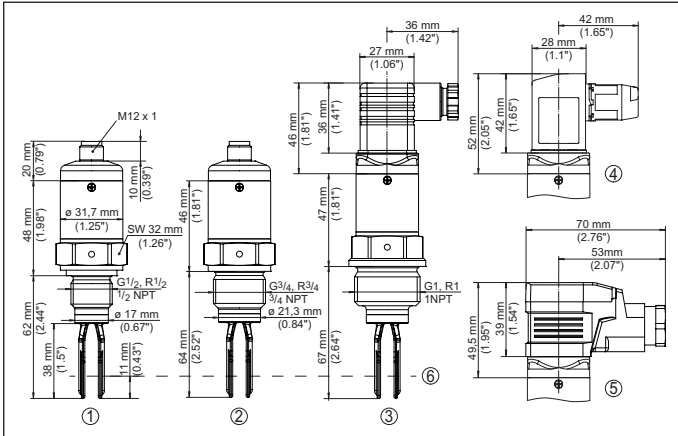

Fig. 41: VEGASWING, standard version, threaded fittings

- 1 Thread G $\frac{1}{2}$  (DIN ISO 228/1),  $\frac{1}{2}$  NPT, M12 x 1 plug <sup>1)</sup>
- 2 Thread G $\frac{3}{4}$  (DIN ISO 228/1),  $\frac{3}{4}$  NPT, M12 x 1 plug
- 3 Thread G1 (DIN ISO 228/1), 1 NPT, valve plug ISO 4400
- 4 Valve plug ISO 4400 with IDC method of termination
- 5 Valve plug ISO 4400 with hinged cover
- 6 Switching point

### VEGASWING 51, high temperature version

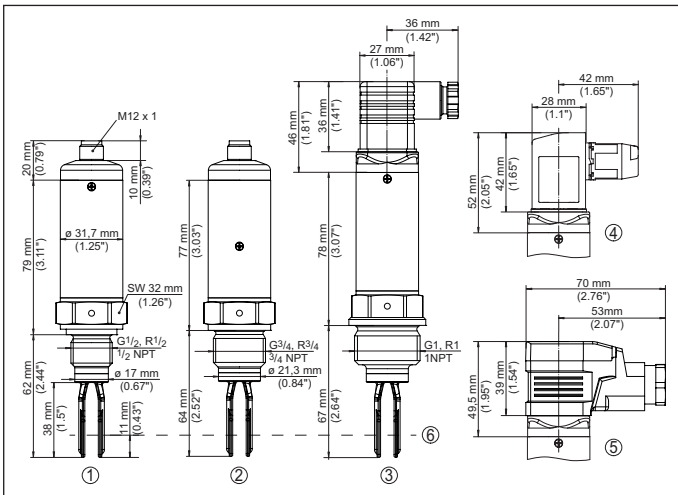

Fig. 42: VEGASWING, high temperature versions, threaded fittings

- 1 Thread G $\frac{1}{2}$  (DIN ISO 228/1),  $\frac{1}{2}$  NPT, M12 x 1 plug
- 2 Thread G $\frac{3}{4}$  (DIN ISO 228/1),  $\frac{3}{4}$  NPT, M12 x 1 plug
- 3 Thread G1 (DIN ISO 228/1), 1 NPT, valve plug ISO 4400
- 4 Valve plug ISO 4400 with IDC method of termination
- 5 Valve plug ISO 4400 with hinged cover
- 6 Switching point

### VEGASWING 51, hygienic versions

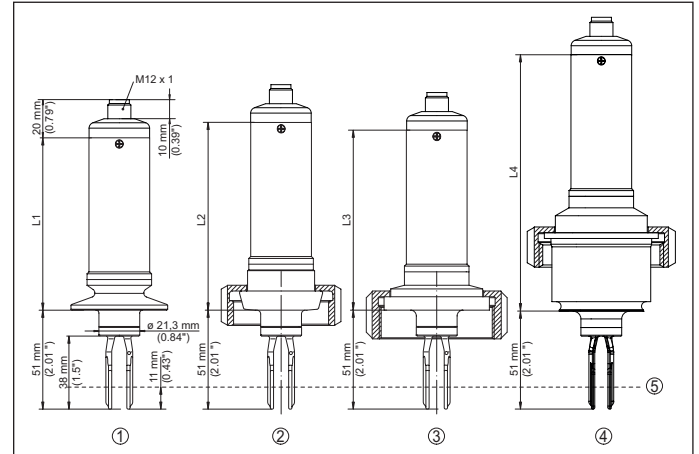

Fig. 43: VEGASWING, hygienic versions, hygienic fittings

- 1 Clamp, M12 x 1 plug
  - 2 Slotted nut, M12 x 1 plug
  - 3 SMS 1145, M12 x 1 plug
  - 4 Hygienic fitting with compression nut, M12 x 1 plug
  - 5 Switching point
- L1 Length with Clamp  
 Clamp 1": 90 mm (3.54 in)  
 Clamp 1½": 90 mm (3.54 in)  
 Clamp 2": 89 mm (3.50 in)
- L2 Length with slotted nut  
 DN 25 PN 40: 98 mm (3.86 in)  
 DN 40 PN 40: 103 mm (4.06 in)  
 DN 50 PN 25: 104 mm (4.09 in)
- L3 Length with SMS  
 DN 38 PN 6: 94 mm (3.70 in)
- L4 Length with aseptic fitting  
 134 mm (5.28 in)

### VEGASWING 53, standard version, threaded fittings

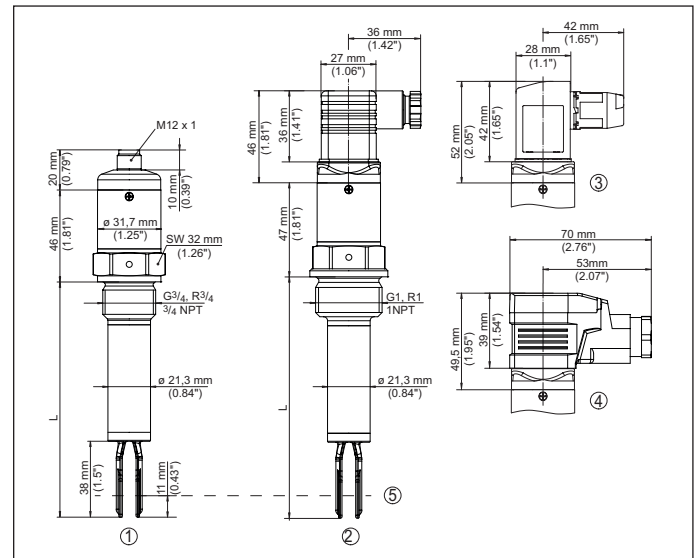

Fig. 44: VEGASWING, standard version, threaded fittings

- 1 M12 x 1, Thread G $\frac{3}{4}$  (DIN ISO 228/1),  $\frac{3}{4}$  NPT <sup>2)</sup>
  - 2 Valve block ISO 4400, Thread G1 (DIN ISO 228/1), 1 NPT
  - 3 Valve plug ISO 4400 with IDC method of termination
  - 4 Valve plug ISO 4400 with hinged cover
  - 5 Switching point
- L Sensor length

<sup>1)</sup> Keep in mind that the total length is extended by the plug connection.

<sup>2)</sup> Keep in mind that the total length is extended by the plug connection.

**VEGASWING 53, high temperature versions, threaded fittings**

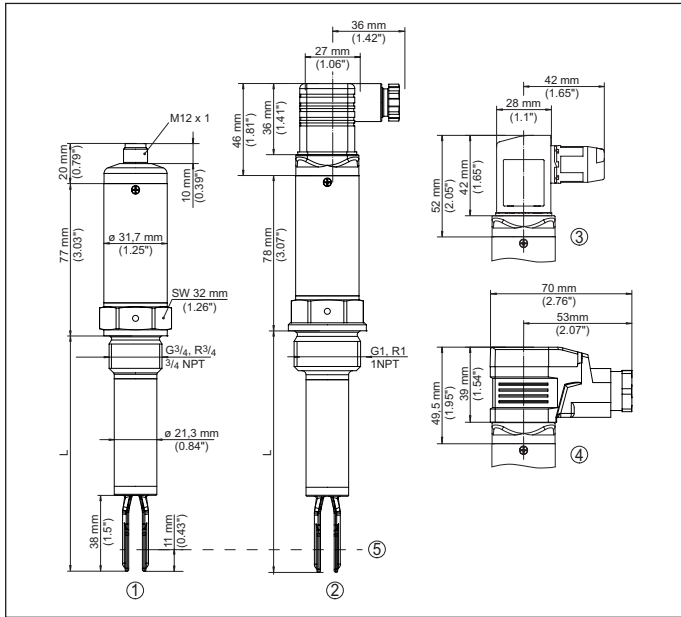

Fig. 45: VEGASWING, high temperature versions, threaded fittings

- 1 M12 x 1, Thread G $\frac{3}{4}$  (DIN ISO 228/1),  $\frac{3}{4}$  NPT<sup>3)</sup>
- 2 Valve block ISO 4400, Thread G1 (DIN ISO 228/1), 1 NPT
- 3 Valve plug ISO 4400 with IDC method of termination
- 4 Valve plug ISO 4400 with hinged cover
- 5 Switching point
- L Sensor length

**VEGASWING 53, hygienic versions, hygienic fittings**

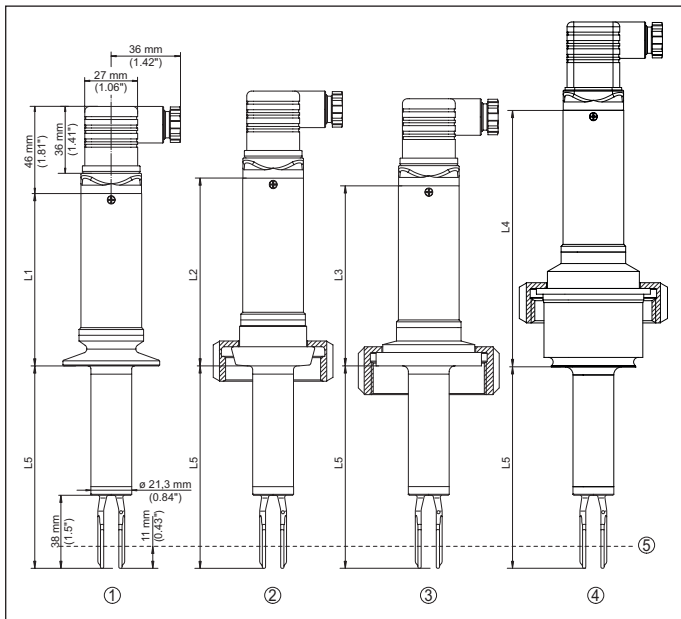

Fig. 46: VEGASWING, hygienic versions, hygienic fittings

- 1 Valve plug ISO 4400, Clamp
- 2 Valve plug ISO 4400, slotted nut
- 3 Valve plug ISO 4400, SMS 1145
- 4 Valve plug ISO 4400, hygienic connection with compression nut
- 5 Switching point
- L1 Clamp 1": 90 mm (3.54 in)  
Clamp 1½": 90 mm (3.54 in)  
Clamp 2": 89 mm (3.50 in)
- L2 Slotted nut DN 25 PN 40: 98 mm (3.86 in)  
Slotted nut DN 40 PN 40: 103 mm (4.06 in)  
Slotted nut DN 50 PN 25: 104 mm (4.09 in)
- L3 SMS fitting: 94 mm (3.70 in)
- L4 Hygienic fitting: 134 mm (5.28 in)

<sup>3)</sup> Keep in mind that the total length is extended by the plug connection.

**Housing VEGASWING 61, 63, 66**

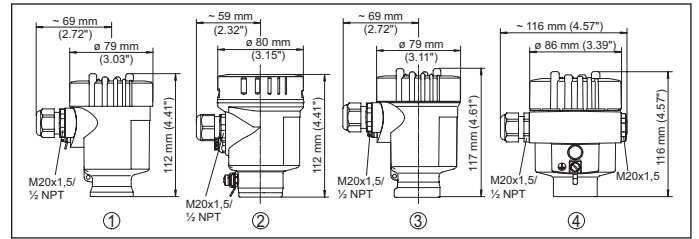

Fig. 47: Housing versions for VEGASWING 61, 63, 66

- 1 Plastic housing
- 2 Stainless steel housing (electropolished)
- 3 Stainless steel housing (precision casting)
- 4 Aluminium housing

**Housing in protection IP66/IP68 (1 bar)**

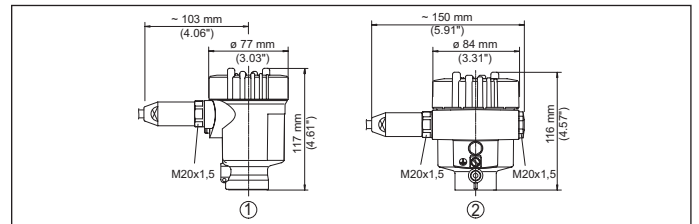

Fig. 48: Housing versions with protection rating IP66/IP68 (1 bar) for VEGASWING 61, 63, 66

- 1 Stainless steel housing (precision casting)
- 2 Aluminium housing

**VEGASWING 61**

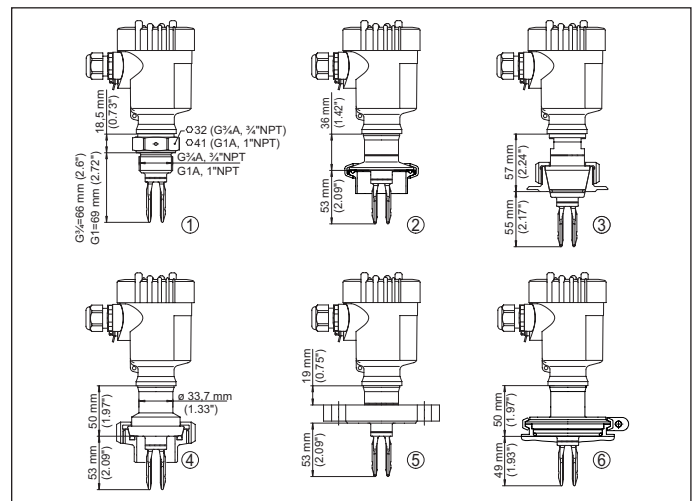

Fig. 49: VEGASWING 61

- 1 Thread
- 2 Clamp
- 3 Cone DN 25
- 4 Slotted nut DN 40
- 5 Flange
- 6 Gas-tight leadthrough
- 7 Temperature adapter



VEGASWING 63

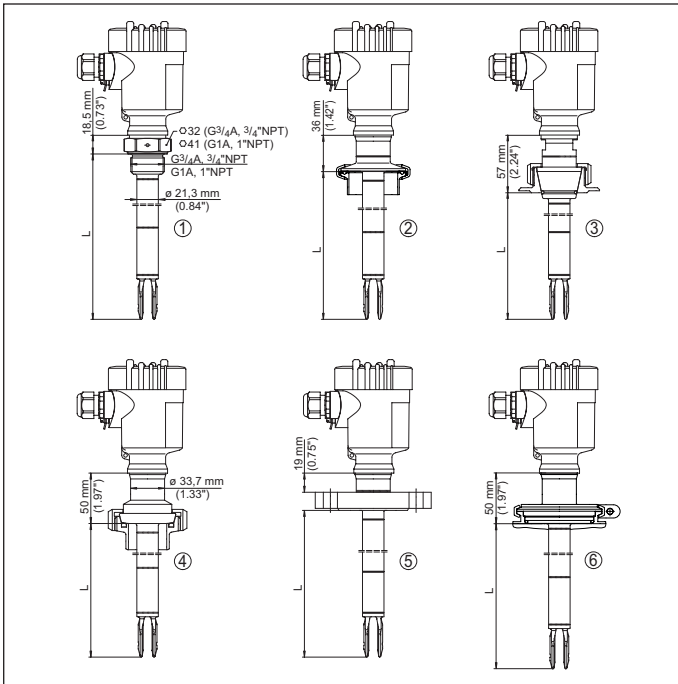

Fig. 50: VEGASWING 63

- 1 Thread
- 2 Clamp
- 3 Cone DN 25
- 4 Slotted nut DN 40
- 5 Flange
- 6 Gas-tight leadthrough
- 7 Temperature adapter
- L Sensor length, see chapter "Type overview"

Temperature adapter - VEGASWING 61, 63

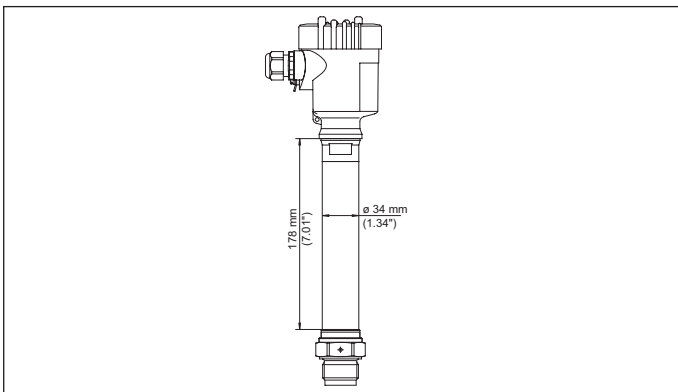

Fig. 51: Temperature adapter up to +250 °C (+482 °F) for VEGASWING 61 and 63

VEGASWING 66

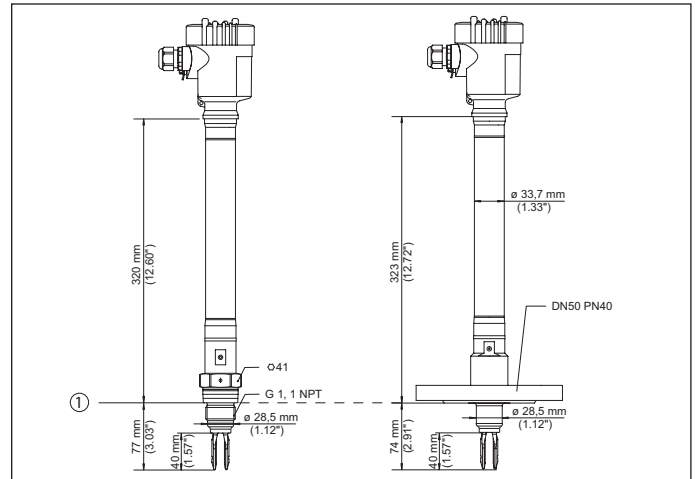

Fig. 52: VEGASWING 66 - compact version, -196 ... +450 °C (-321 ... +842 °F)

- 1 Sealing surface

VEGASWING 66

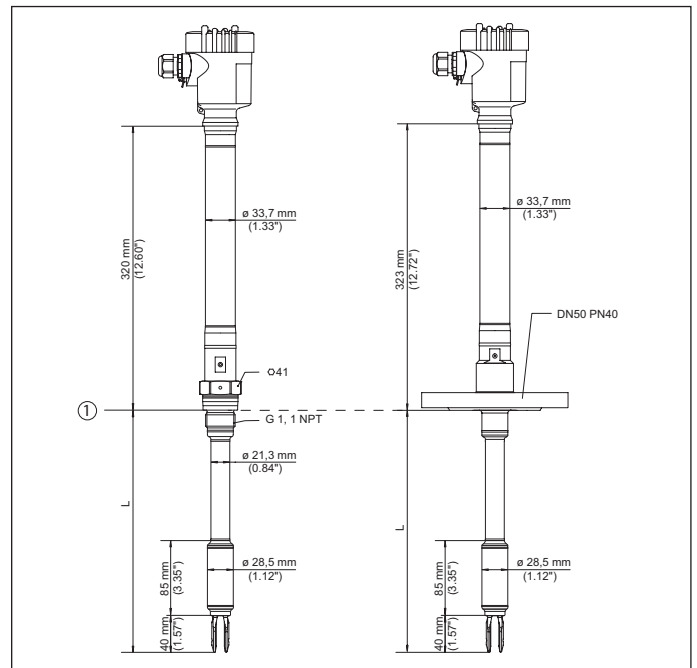

Fig. 53: VEGASWING 66 - tube version, -196 ... +450 °C (-321 ... +842 °F)

- 1 Sealing surface
- L Sensor length, see chapter "Type overview"







All statements concerning scope of delivery, application, practical use and operating conditions of the sensors and processing systems correspond to the information available at the time of printing.  
Subject to change without prior notice

© VEGA Grieshaber KG, Schiltach/Germany 2022

VEGA Grieshaber KG  
Am Hohenstein 113  
77761 Schiltach  
Germany

Phone +49 7836 50-0  
E-mail: [info.de@vega.com](mailto:info.de@vega.com)  
[www.vega.com](http://www.vega.com)

**VEGA**

30115-EN-221212