

Series 3730

Type 3730-1 Electropneumatic Positioner

SAMSON

Application

Single-acting or double-acting positioner for attachment to pneumatic control valves. Self-calibrating, automatic adaptation to valve and actuator.

Set point 4 to 20 mA

Travels 3.75 to 200 mm

Opening angle 24 to 100°

CE Ex certified

The positioner ensures a predetermined assignment of the valve position (controlled variable x) to the input signal (set point w). It compares the input signal received from a control system to the travel or rotational angle of the control valve and issues a corresponding output signal pressure (output variable y).

Special features

- Simple attachment to all common linear and rotary actuators with interface for SAMSON direct attachment, NAMUR rib or valves with rod-type yokes according to IEC 60534-6-1, or to rotary actuators according to VDI/VDE 3845
- Any desired mounting position of the positioner
- Simple single-knob, menu-driven operation
- LCD easy to read in any mounted position due to selectable reading direction
- Variable, automatic start-up
- Preset parameters - only values deviating from the standard need to be adjusted
- Calibrated travel sensor without gears susceptible to wear
- Permanent storage of all parameters in EEPROM (protected against power failure)
- Two-wire system with a small electrical load of 300 Ω
- Tight-closing function can be activated
- Continuous monitoring of zero point
- Two standard programmable position alarms

Version

- **Type 3730-1:** electropneumatic positioner with on-site operation and LCD

Additional options

- Inductive limit contact with proximity switches
- Stainless steel housing



Principle of operation

The positioner is mounted on pneumatic control valves and is used to assign the valve position (controlled variable x) to the control signal (set point w). The positioner compares the electric control signal of a control system to the travel or opening angle of the control valve and issues a signal pressure (output variable y) for the pneumatic actuator.

The positioner mainly consists of an electric travel sensor system (2), an analog i/p module with a downstream air capacity booster and the electronics with the microcontroller (5).

When a set point deviation occurs, the actuator is either vented or filled with air. If necessary, the signal pressure change can be slowed down with a volume restriction that can be connected as necessary.

A constant air stream with a fixed set point to the atmosphere is created by flow regulator (9) with a fixed set point.

The i/p module (6) is supplied with a constant upstream pressure by the pressure regulator (8) to compensate for any fluctuations in the supply pressure.

Operation

The positioner is operated with a user-friendly rotary pushbutton. The parameters are selected by turning the knob, pushing it activates the required setting. In the menu, all parameters are listed in one level, eliminating the need to search in sub-menus. All parameters can be checked and changed on site.

All values are displayed on the LCD. The reading direction of the LCD can be rotated by 180° .

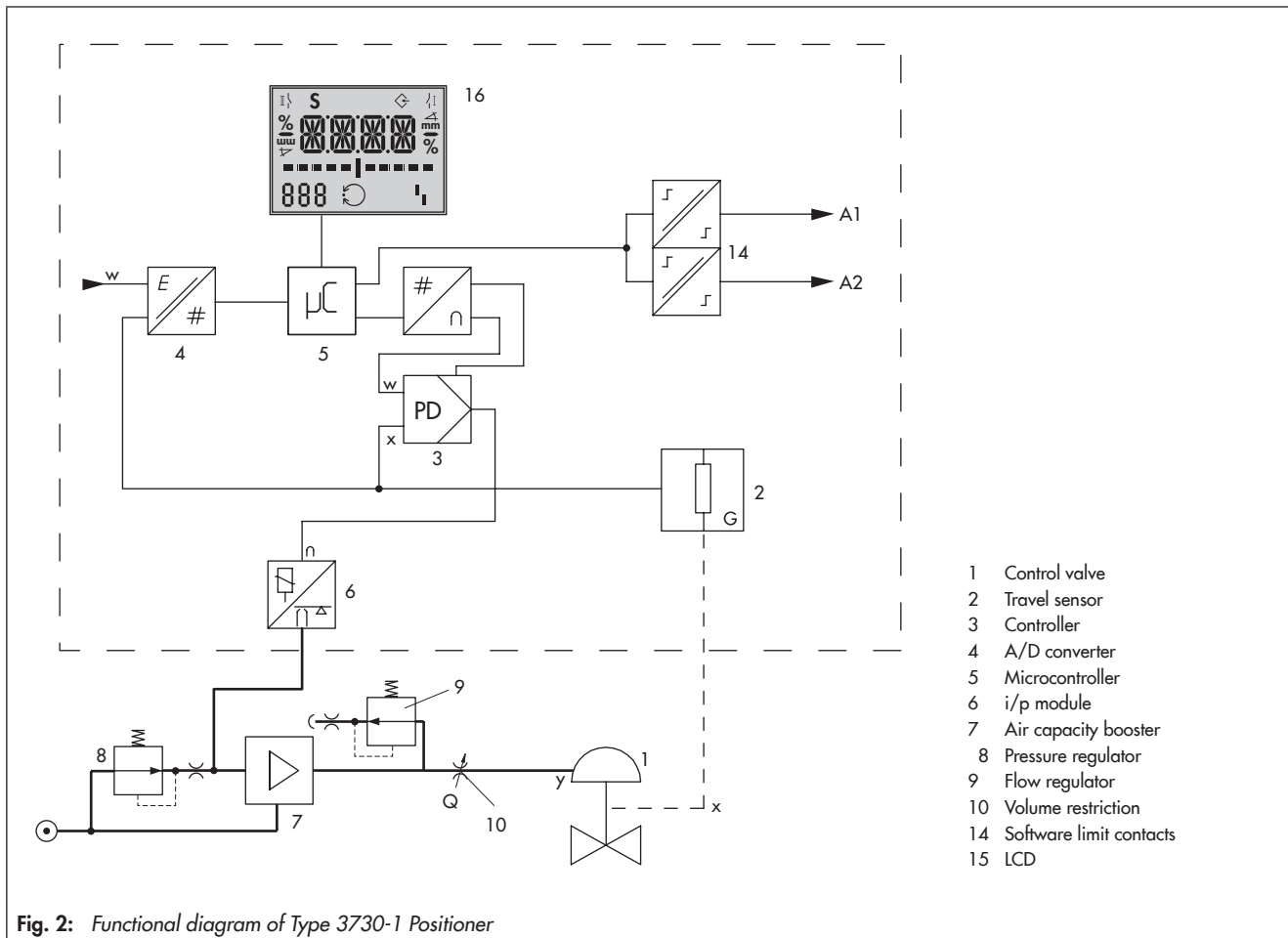

Fig. 2: Functional diagram of Type 3730-1 Positioner

Table 1: Technical data of Type 3730- Positioner











The technical data for the explosion-protected devices may be restricted by the limits specified in the test certificates.			
Travel	Adjustable	Direct attachment to Type 3277 Actuator	3.6 to 30 mm
		Attachment according to IEC 60534-6 (NAMUR)	3.6 to 200 mm
		Attachment to rotary actuators according to VDI/VDE 3845	24 to 100° opening angle
Travel range		Adjustable within the initialized travel/angle of rotation; travel can be restricted to 1/5 at the maximum	
Set point w	Signal range	4 to 20 mA · Two-wire device, reverse polarity protection	
	Split-range operation	4 to 11.9 mA and 12.1 to 20 mA	
	Static destruction limit	100 mA	
Minimum current		3.7 mA	
Load impedance		≤6 V (corresponding to 300 Ω at 20 mA)	
Supply air	Air quality acc. to ISO 8573-1 (edition 2001-02)	1.4 to 7 bar (20 to 105 psi)	
		Max. particle size and density: Class 4 · Oil content: Class 3 · Pressure dew point: Class 3 or at least 10 K below the lowest ambient temperature to be expected	
Signal pressure (output)		0 bar up to the capacity of the supply pressure · Can be limited to approx. 2.4 bar over software	
Characteristic		Optionally, 1 characteristic for globe valves · 8 characteristics for opening angle	
Hysteresis		≤1 %	
Sensitivity		≤0.1 %	
Transit time		<0.5 s for initialization not permissible · Adaptation over volume restriction Q	
Direction of action		Reversible	
Air consumption		Independent from supply pressure approx. 110 l _n /h	
Air output capacity	to fill actuator with air	At Δp = 6 bar: 8.5 m _n ³ /h · At Δp = 1.4 bar: 3.0 m _n ³ /h · K _{Vmax(20 °C)} = 0.09	
	to vent actuator	At Δp = 6 bar: 14.0 m _n ³ /h · At Δp = 1.5 bar: 4.5 m _n ³ /h · K _{Vmax(20 °C)} = 0.15	
Permissible ambient temperature		-20 to 80 °C in all versions -45 to 80 °C with metal cable gland -25 to 80 °C with inductive limit contact (SJ2-S1N) and metal cable gland The temperature limits for the explosion-protected devices may be restricted by the limits specified in the test certificates.	
Influences	Temperature	≤0.15 %/10 K	
	Supply air	None	
	Effect of vibration	≤0.25 % up to 2000 Hz and 4 g according to IEC 770	
Electromagnetic compatibility		Complying with EN 61000-6-2, EN 61000-6-3, EN 61326-1 and NAMUR Recommendation NE 21	
Electrical connections		One M20 x 1.5 cable gland for 6 to 12 mm clamping range · Second M20 x 1.5 threaded connection additionally exists · Screw terminals for 0.2 to 2.5 mm ² wire cross-sections	
Explosion protection		See Table 2	
Degree of protection		IP 66/NEMA 4X	
Use in safety-instrumented systems (SIL)		Observing the requirements of IEC 61508, the systematic capability of the pilot valve for emergency venting as a component in safety-instrumented systems is given.	
		Use is possible on observing the requirements of IEC 61511 and the required hardware fault tolerance in safety-instrumented systems up to SIL 2 (single device/HFT = 0) and SIL 3 (redundant configuration/HFT = 1).	
Weight		1.0 kg	
Compliance			
Materials			
Housing		Die-cast aluminum EN AC-ALSi12(Fe) (EN AC-44300) acc. to DIN EN 1706, chromated and powder coated · Special version: stainless steel 1.4581	
External parts		Stainless steel 1.4571 and 1.4301	
Cable gland		M20 x 1.5, black polyamide	
Binary contacts			
Two software limit contacts with configurable limits (0.5 % steps), reverse polarity protection, floating · See rows below for default settings			
Signal state		Version without explosion protection	Ex
		No response: Conductive (R = 348 Ω) Response: Non-conducting	No response: ≥ 2.2 mA Response: ≤ 1.0 mA
Operating voltage		For connection to the binary input of the PLC acc. to IEC 61131-2, P _{max} = 400 mW or for connection to NAMUR switching amplifier acc. to EN 60947-5-6	For connection to NAMUR switching amplifier acc. to EN 60947-5-6
Options			
Pepperl+Fuchs inductive limit contact		For connection to switching amplifier acc. to EN 60947-5-6. Can be used in combination with a software limit contact.	
	SJ2-SN proximity switch	Measuring plate not detected: ≥3 mA · Measuring plate detected: ≤1 mA	
	SJ2-S1N proximity switch	Measuring plate not detected: ≤1 mA · Measuring plate detected: ≥3 mA	

Table 2: Explosion protection certificates

Type	Certification			Type of protection/comments	
3730	-1	STCC	Number	972	0Ex ia IIC T6X; 2Ex s II T6 X
			Valid until	2017-10-01	
	-11	 EC type examination certificate	Number	PTB 04 ATEX 2033	II 2G Ex ia IIC T6 Gb; II 2D Ex tb IIIC T80°C Db IP66
			Date	2013-11-27	
		CCoE	Number	A/P/HQ/MH/144/1164	Ex ia IIC T6
			Date	2014-10-27	
			Valid until	2019-10-26	
		Number	RU C-DE08.B.00113	1Ex ia IIC T6 Gb; 1Ex tb IIIC T80°C Db IP66	
		Date	2013-11-15		
		Number	IECEx PTB 06.0055	Ex ia IIC T6	
		Date	2006-11-02		
	-13		INMETRO		Ex ia IIC T4~T6 Gb
			On request		
Number			GYJ14.1109		
-18		Number	1675820	Ex ia IIC T6; Class I, Zone 0; Class II, Groups E, F, G; Ex nA II T6; Class I, Zone 2 Class I, Div.2, Groups A, B, C, D Class II, Div.2, Groups E, F, G Class III: Type 4 Enclosure	
		Date	2010-07-19		
		Number	3023478		
-18		Date	2008-11-03	Class I, Zone 0 AEx ia IIC Class I, II, III, Div.1, Groups A, B, C, D, E, F, G Class I, Div.2, Groups A, B, C, D Class II, Div.2, Groups F, G NEMA Type 4X	
		Number	PTB 04 ATEX 2114 X		
		Date	2008-02-26		
-18	 Certificate of conformity	Number	RU C DE.08.B.00113	II 3G Ex nA II T6 Gc, II 3G Ex ic IIC T6 Gc; II 3D Ex tc IIIC IP66 Dc T80°C	
		Date	2013-11-15		
		Valid until	2018-11-14		
	Number	GYJ14.1110X	Ex ic IIC T4~T6 Gc; Ex nA IIC T4~T6 Gc		
	Date	2014-05-08			
	Valid until	2019-05-07			

* Designation according to the EN 60079 standard series

Dimensions in mm

Direct attachment

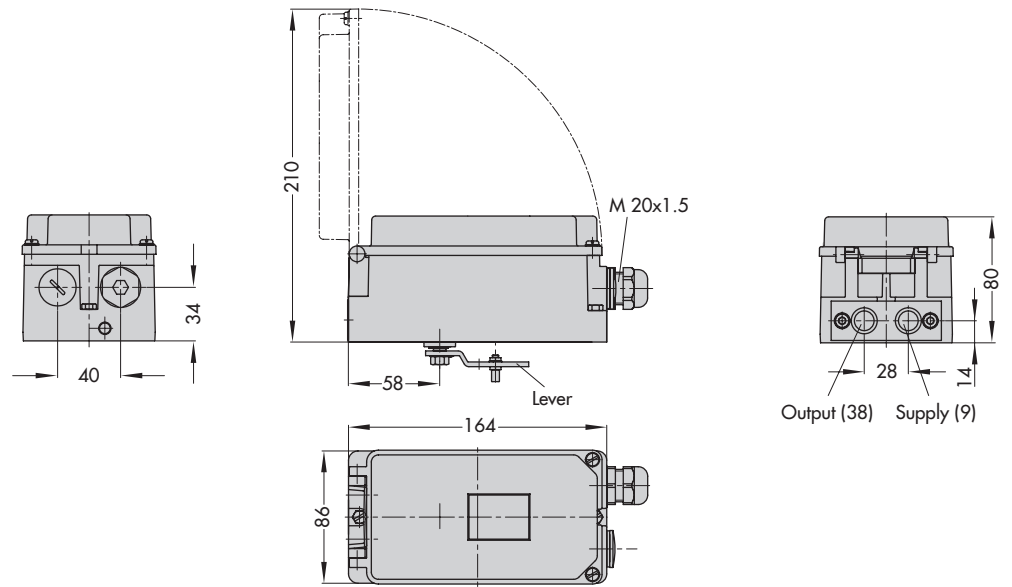

Attachment according to IEC 60534-6 (NAMUR)

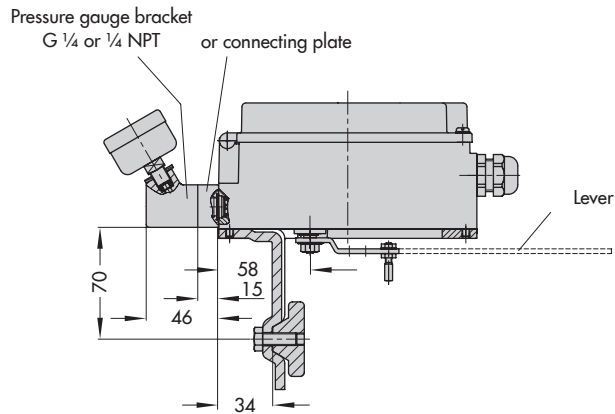

Attachment according to VDI/VDE 3847

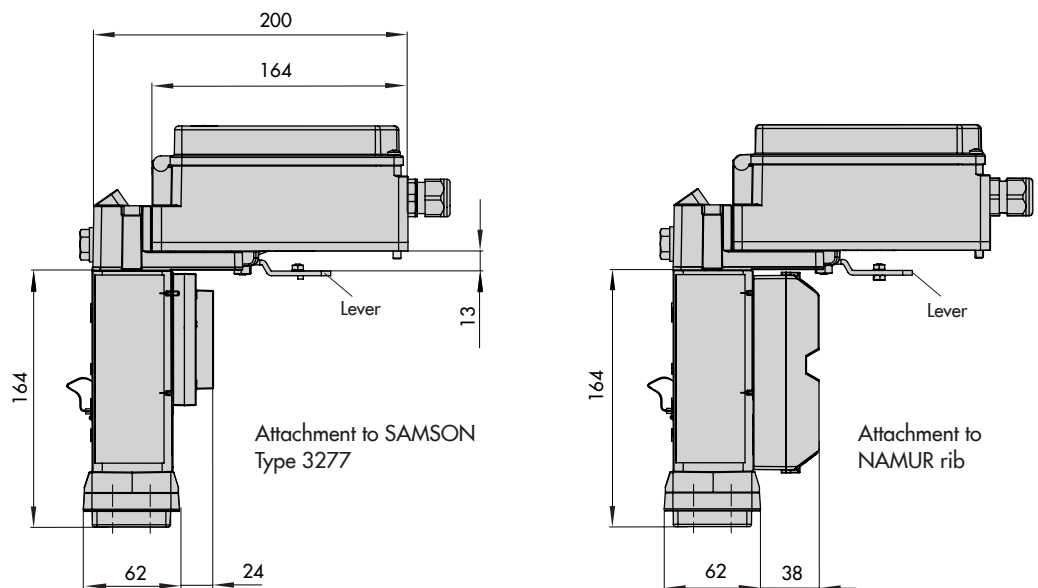

Dimensions in mm

Attachment to rotary actuators

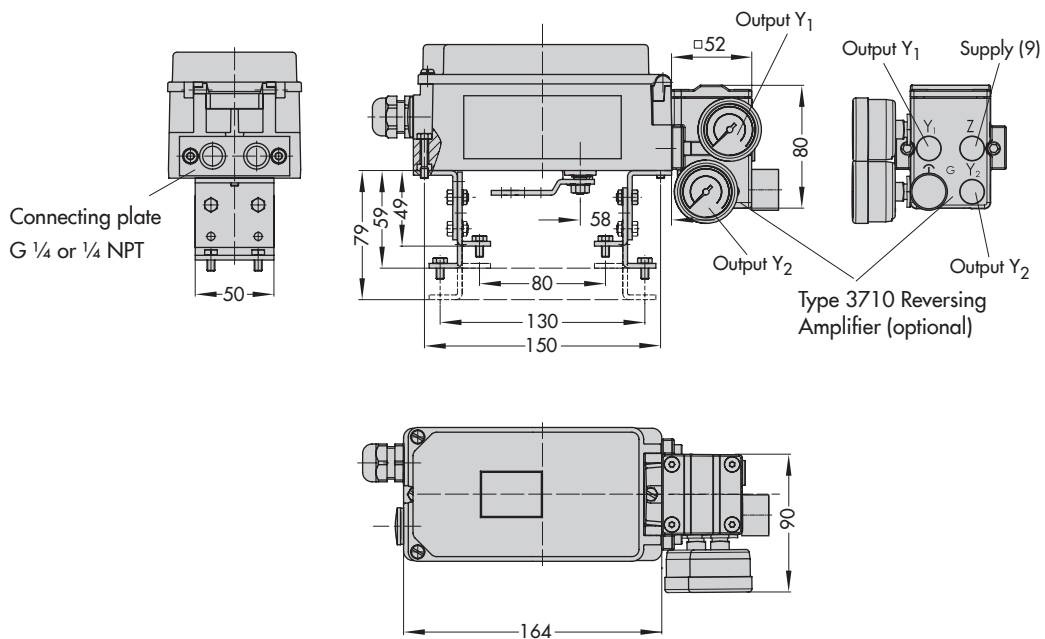

Lever

Lever	x	y	z
S	17 mm	25 mm	33 mm
M	25 mm	50 mm	66 mm
L	70 mm	100 mm	116 mm
XL	100 mm	200 mm	216 mm

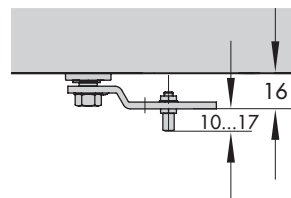
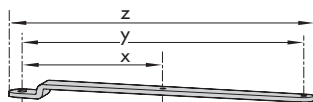

Article code

Positioner	Type 3730-1	x	x	0	0	0	0	0	0	0	0	x	0	0	x	0	0	0
With LCD and autotune, 4 to 20 mA set point, two software limit contacts*																		
Explosion protection																		
Without		0																
ATEX: II 2G Ex ia IIC T6 Gb, II 2D Ex tb IIIC T80°C Db IP66		1																
FM/CSA:		3																
Class I, Zone 0 AEx ia IIC; Class I, II, III, Div.1, Groups A–G; Class I, Div.2, Groups A–D; Class II, Div.2, Groups F, G/ Ex ia IIC T6; Class I, Zone 0; Class II, Groups E–G; Ex nA II T6; Class I, Zone 2; Class I, Div.2, Groups A–D; Class II, Div.2, Groups E–G																		
ATEX: II 3G Ex nA II T6, II 3G Ex ic IIC T6; II 3D Ex td A21 IP54/IP66 T80°C		8																
Option: Inductive limit contact																		
Without		0																
With SJ2-SN proximity switch (NC contact)		1																
With SJ2-S1N proximity switch (NO contact)		0	2															
Housing material																		
Aluminum (standard)												0						
Stainless steel 1.4581												1						
Special applications																		
Without																		0
Device compatible with paint (lowest permissible ambient temperature –20 °C)																		1
Exhaust air port with ¼ NPT thread, back of housing sealed																		2
Special version																		
Without																		0 0 0

* Additional functions such as limit switches, solenoid valve, position transmitter or external position sensor, e.g. with Type 3730-2 Positioner

Mounting the positioner

The Type 3730 Electropneumatic Positioner can be attached directly to the Type 3277 Actuator over a connection block.

In actuators with fail-safe action “actuator stem extends” and Type 3277-5 Actuator (120 cm²), the signal pressure is routed over an internal hole in the actuator yoke to the actuator.

In actuators with fail-safe action “actuator stem retracts” and in actuators with effective diaphragm areas of 175 cm² or larger, the signal pressure is routed to the actuator over ready-made external piping.

Using the appropriate bracket, the positioner can also be attached according to IEC 60534-6-1 (NAMUR recommendation). The positioner can be mounted on either side of the control valve.

A pair of universal brackets is used for the attachment to Type 3278 Rotary Actuators or other rotary actuators according to VDI/VDE 3845. The rotary motion of the actuator is transferred to the positioner over a coupling wheel with scale.

Ordering text

Positioner Type 3730-1x

- Without pneumatic connecting rail (only when directly attached to Type 3277)
- With pneumatic connecting rail ISO 228/1-G ¼
- With pneumatic connecting rail ¼-18 NPT
- Without/with pressure gauge up to max. 6 bar
- Additional cover label with list of parameters and operating instructions in English/Spanish or English/French (standard version German/English)
- Attachment to Type 3277 Actuator (120 to 750 cm²)
- Attachment acc. to IEC 60534-6-1 (NAMUR)
Travel: ... mm, if applicable, stem diameter: ... mm
- Attachment to Type 3278 Rotary Actuator (160/320 cm²)
- Attachment to rotary actuators according to VDI/VDE 3845
- Pneumatic reversing amplifier for double-acting actuators with connection acc. to ISO 228/1-G ¼ or ¼-18 NPT
- Adapter M20 x 1.5 to ½ NPT
- Metal cable gland
- Free of substances that impair paint adhesion
- Exhaust air port with ¼ NPT thread
- Special version: housing made of CrNiMo steel

Specifications subject to change without notice



SAMSON AG · MESS- UND REGELTECHNIK
Weismüllerstraße 3 · 60314 Frankfurt am Main, Germany
Phone: +49 69 4009-0 · Fax: +49 69 4009-1507
samson@samson.de · www.samson.de

T 8384-1 EN

2016-04-15 · English