

## EL-O-Matic E and P Series

Technical data pneumatic Rack and Pinion actuators



# Data sheet

Sheet No.: A1.102 Rev. B  
Date: June 2010

## TECHNICAL DETAILS, STANDARD ACTUATOR

E/P

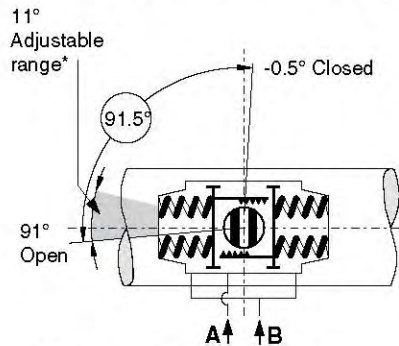
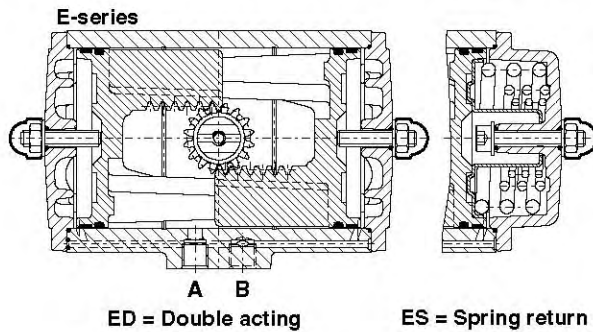
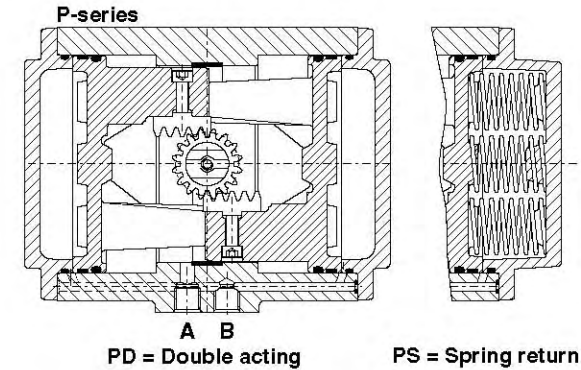

\* only standard on E-Series actuators

### Specification

Pressure range : Double acting 20 to 120 psi  
: Spring return 80 to 120 psi, with max. spring set 40 to 120 psi, reduced spring quantity

Torque : 180° actuators 87 psi maximum  
: 1133 to 40,000 in.lb at 80psi supply  
See torque datasheets 1.104.01 and 1.104.02

Operating media : Air, dry or lubricated and inert gasses  
: For sub-zero applications take appropriate measures

Temperature : -4° to +176°F

Lubrication : Factory lubricated for the normal life of the actuator

Construction : Suitable for indoor and outdoor installation

Finish : Polyester non-TGIC based powder coating (see data sheet A4.204.01)

Rotation : 91.5° (-0.5° CW to 91° CCW)

Double acting : Standard counter clockwise with port "A" pressurized (code A, see data sheet A1.503 for other assembly codes)

Spring return : Clockwise fail action (code A, see data sheet A1.504 for other assembly codes)

Limit stops : Standard on E-series. Adjustable range 91°/80°  
: Optional on P-series. See datasheet A1.501.01  
: For double stroke adjustment. See datasheet A1.501.05

### European Directives

PED : All actuators are suitable for use with Group 2 gasses according to Pressure Equipement Directive 97/23/EC

ATEX : Optional : actuators suitable for use with Group 1 gasses  
: All basic actuators are suitable for use in hazardous area's classified II 2 GD, zones 1 or 2 (Gasses) and 21 or 22 (Dust)

### Russian Approvals

EI-O-Matic E and P series pneumatic actuators are available with the GOST-R and Rostechnadzor (RTN) approvals.

### Note

1. Operating time is average with actuator under load and solenoid valve fitted.
2. Air consumption is the actual free air volume at 1 atm.
3. Pressure is in barg.

ACTUATOR TYPE		E12	E25	E40	E65	E100	E150	E200	E350	E600	E950	E1600	P2500	P4000
<b>Bore</b>	inch	1.8	2.2	2.8	3.1	3.6	4.1	4.3	5.7	6.9	7.9	9.1	11.8	12.8
<b>Stroke</b>	inch	0.5	0.6	0.7	0.9	1.0	1.2	1.5	1.5	1.7	2.0	2.5	2.2	3.2
<b>Weight:</b>	<b>Double acting</b>	lb.	1.3	2.9	4.0	5.3	6.8	10.5	12.8	23	43	58	94	125
	<b>Spring return</b>	lb.	1.5	3.7	5.3	7.9	10.1	15.2	20.1	37	61	85	145	194
<b>Operating time</b>	sec.	0.4	0.5	0.7	1.1	1.2	1.8	2.3	3.6	4.5	5.4	6.9	7	12
<b>Air consumption at 1 atm (cu./in.)</b>	<b>port A stroke</b>	3.1	6.1	9.8	20	21	45	49	110	177	287	445	488	824
	<b>port B stroke</b>	3.7	6.7	13	22	30	40	61	116	189	299	488	568	1,068

**EI-O-MATIC™**

www.EI-O-matic.com

Copyright © Emerson Process Management. The information in this document is subject to change without notice.

Updated data sheets can be obtained from our website [www.EI-O-Matic.com](http://www.EI-O-Matic.com) or from your nearest Valve Automation Center **USA:** +1 813 319 0266 **Europe:** +31 74 256 10 10 **Asia-Pacific:** +65 6501 4600

**EMERSON**  
Process Management

# Data sheet

Sheet No.: A1.102.10 Rev. C  
Date: November 2010

## EL-O-MATIC BASIC PNEUMATIC ACTUATOR CONFIGURATION

E/P

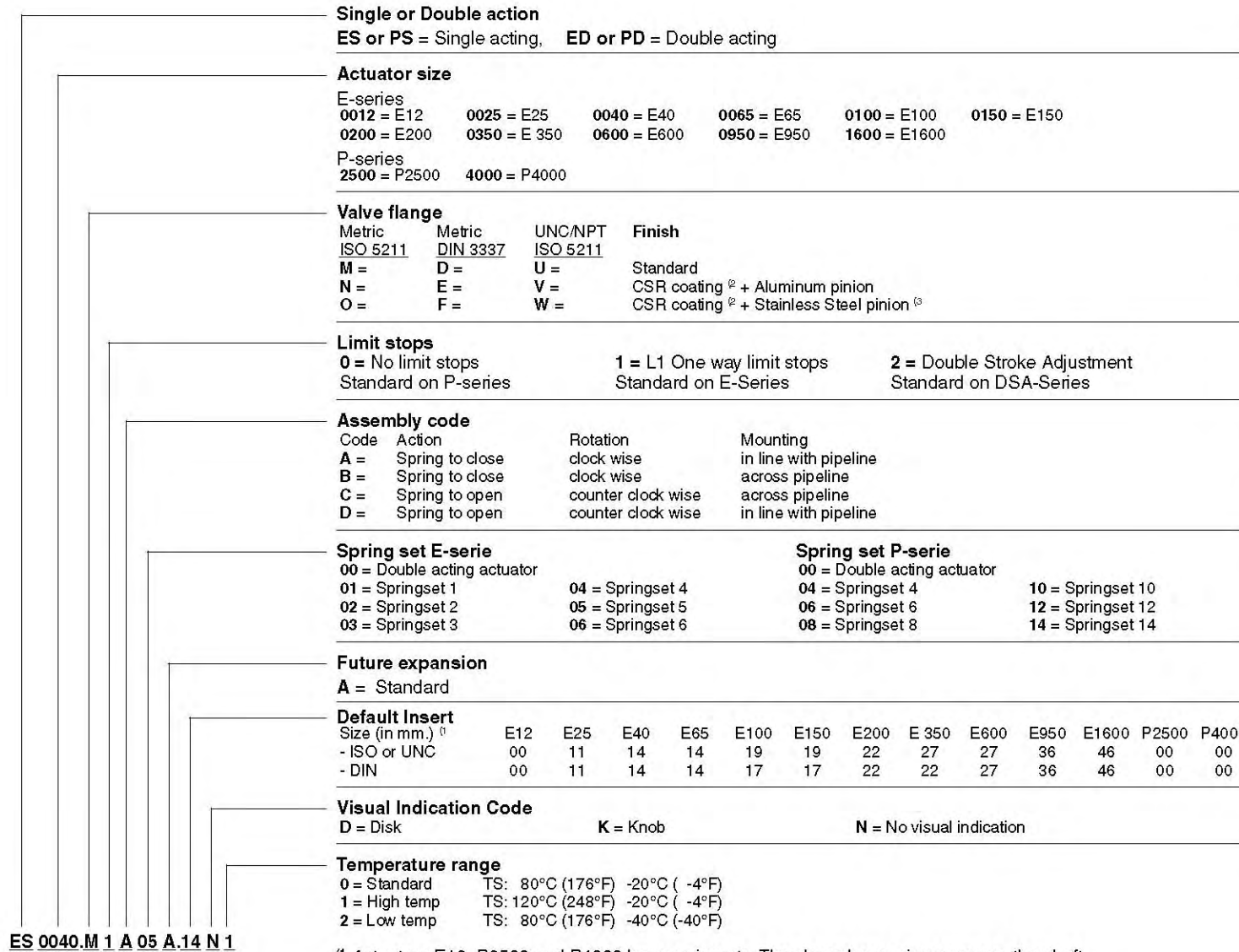

ES 0040.M 1 A 05 A.14 N 1

See following data sheets for more information

A1.104.01 / A1.104.02

A1.103.106 / A1.103.073 /  
A1.103.102 / A1.103.103  
A1.101.30 / A1.101.33 /  
A4.204.01

A1.501.01/  
A1.501.05

A1.503/  
A1.504

A1.104.02

A1.103.073  
A1.103.106  
A1.103.120

A1.101.70 / A1.101.71

<sup>(1)</sup> Actuators E12, P2500 and P4000 have no inserts. They have have a inner square the shaft  
180° actuators are not covered by this configuration matrix.

<sup>(2)</sup> CSR Coating not possible in combination with Double Stroke Adjustment limit stops (DSA series).

<sup>(3)</sup> Stainless Steel Pinion not possible in combination with Double Stroke Adjustment limit stops (DSA series).



www.El-O-matic.com

Copyright © Emerson Process Management. The information in this document is subject to change without notice.

Updated data sheets can be obtained from our website [www.El-O-Matic.com](http://www.El-O-Matic.com) or from your nearest Valve Automation Center **USA:** +1 813 319 0266 **Europe:** +31 74 256 10 10 **Asia-Pacific:** +65 6501 4600



**EMERSON**  
Process Management



# Data sheet

Sheet No.: A1.501.01 Rev. A  
Date: November 2009

## EL-O-MATIC ACTUATOR WITH ONE WAY LIMIT STOPS

L1/LF

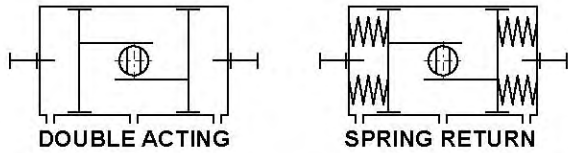

Dim. in inch	ACTUATOR TYPE	
	P2500	P4000
A	22.8	27.9
B	31.3	45.4
C	14.0	15
D	1.2	1.2

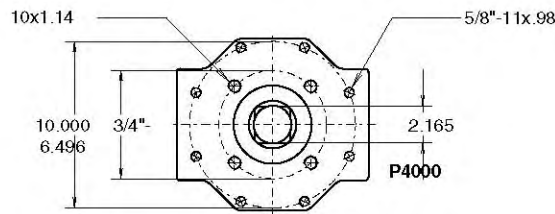
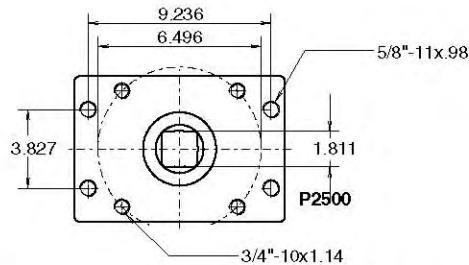
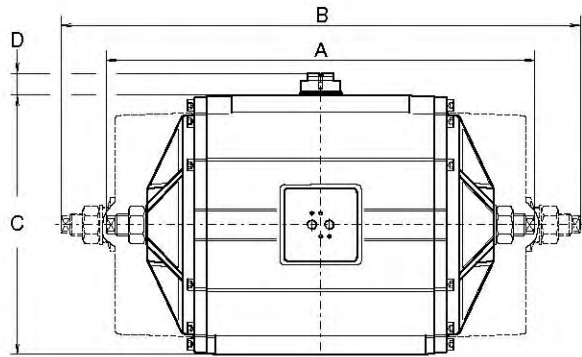

**Note:** Do not adjust under pressure

### Description

Actuators with one way adjustable limit stops are used where the maximum opening (or closing) position of the valve needs to be reduced. For instance to adjust the maximum capacity of a remote operated valve. Also actuators with 180° rotation are available with these stops.

### Operation

Stop screws are fitted to both endcaps and the screw length is such that adjustment is possible through the specified rotation of the actuator. The modified endcap is machined for -0.5° to +93° rotation for all P-series models.

### Identification

"L1" is added to the basic part number i.e. PD2500-L1

### Specification:

Pressure : Up to 120 PSI  
Media : Air, dry or lubricated or non-corrosive gas  
Torque (90°) : Data sheet A1.104.01 - A1.104.04  
(180°) : Data sheet P-series A1.204.01 and A1.204.02  
Other dimensions : Data sheet A 1.103.XXX (90°)  
: Data sheet A 1.203.011 (180°)  
Temperature : -4.0° to +176°F  
Adjustable range : 80°-93° (90°) or 160°-186° (180°)

### Adjustable position (see data sheet A1.503 or A1.504)

code	position	
A	Valve open	(spring to close)
B	Valve open	(spring to close)
C	Valve closed	(spring to open)
D	Valve closed	(spring to open)

### Note:

- 1) Can be provided with extra long screws for full range adjustment (identification: PD2500-LF)
- 2) This option in combination of a manual override gearbox is redundant

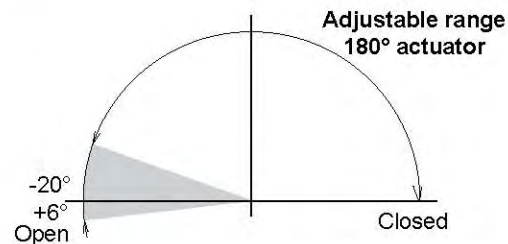
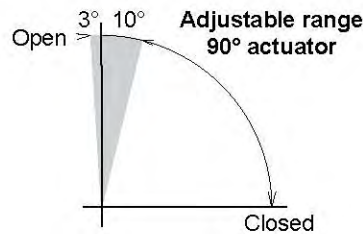

**EL-O-MATIC™**

www.El-O-matic.com

Copyright © Emerson Process Management. The information in this document is subject to change without notice.

Updated data sheets can be obtained from our website [www.El-O-Matic.com](http://www.El-O-Matic.com) or from your nearest Valve Automation Center **USA:** +1 813 319 0266 **Europe:** +31 74 256 10 10 **Asia-Pacific:** +65 6501 4600

**EMERSON**  
Process Management

# Data sheet

Sheet No.: A1.501.03 Rev. A  
Date: November 2009

## LIMIT STOP PLATE DIMENSIONS

LS 420

### Description

These limit stop plates are used when precise control is required for both end of stroke positions. It is possible to adjust 15° of both ends of the standard stroke.

### Construction

The complete stop plate assembly may be added to the 90° P- series actuators. The assembly is normally sandwiched between the actuator and mounting surface of the valve or bracket. Bearing rings are used at both surfaces to provide a long life expectancy.

The unit is assembled with a drive adaptor which passes through the stop plate, into the square actuator and provides the coupling between the two components. This drive adaptor normally also accommodates the coupling of the valve stem.

### Identification

"LS420" is added to the basic part number i.e. PD2500-LS420

### Other dimensions

See data sheet A1.103.xxx

### Option

Version for 180° or DIN-standard actuator

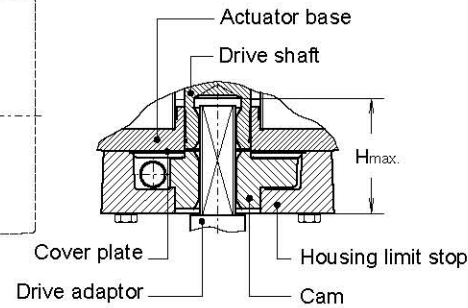
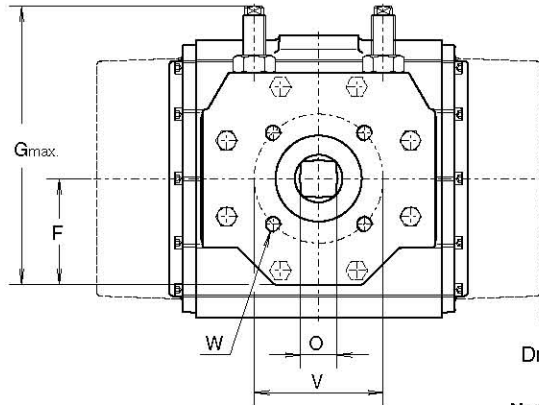
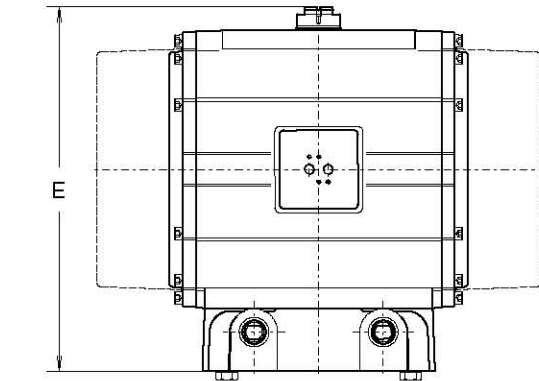

Note: Cover plate only in combination with P2500

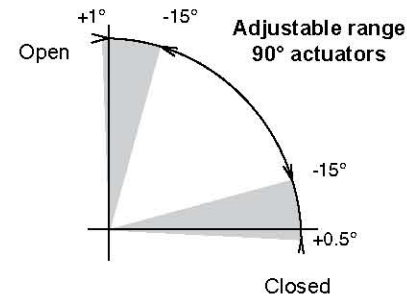

Dim. in inches	ACTUATOR TYPE	
	P2500	P4000
E	18.3	19.3
F	5.3	5.3
G	12.7	12.7
H	5.1	5.6
O	1.8	2.2
V	165	165
W	M20x30	M20x30

**EL-O-MATIC™**

www.El-O-matic.com

Copyright © Emerson Process Management. The information in this document is subject to change without notice.

Updated data sheets can be obtained from our website [www.El-O-Matic.com](http://www.El-O-Matic.com) or from your nearest Valve Automation Center **USA:** +1 813 319 0266 **Europe:** +31 74 256 10 10 **Asia-Pacific:** +65 6501 4600

**EMERSON**  
Process Management



# Data sheet

Sheet No.: A1.501.05 Rev. A  
Date: November 2009

## EL-O-MATIC ACTUATOR WITH DOUBLE STROKE ADJUSTMENT

DSA

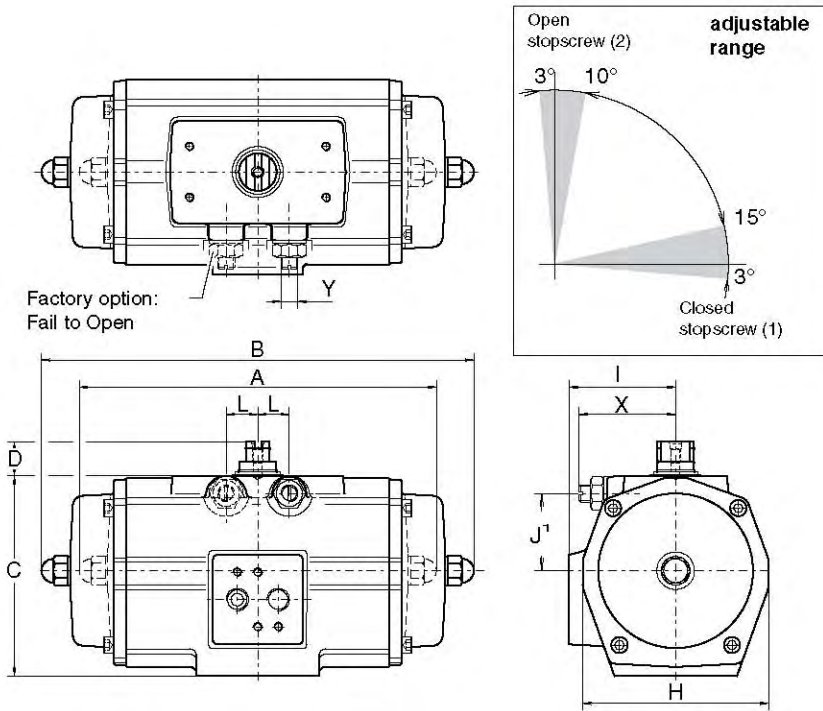

### Description

Actuators with double stroke adjustment are normally used for high performance butterfly valves where a fine adjustment is required for the closed position. In this version adjustment is provided at the end of the opening and closing stroke positions. DSA actuators may be double acting or spring return, though are normally used as spring return (fail close) actuators.

### Operation

The closed position is adjusted by means of the stop-screw (1) located in the actuator body and for the open position by the stop-screws (2) in the actuator end caps.

### Identification

See data sheet A1.102.10

### Specification

Pressure : Up to 120 psi  
 Operating media : Air, dry or lubricated or non-corrosive gas  
 Torque (90°) : Data sheet A1.104.01 - A1.104.02  
 Rotation -  
 - Spring return : Clock-wise on air failure.  
 - Double acting : Counter clock-wise with port "A" pressurised.  
 Other dimensions : Data sheet A1.103.XXX  
 Temperature : -4° to +176° F  
 Adjustable range : Closed position (1), -3° - 15°  
 Open position (2), 80° - 93°

### Note

- 1) Can be provided with extra long end-cap stop screws for full range adjustment of the "open" position.
- 2) This DSA option is not required on actuators fitted with manual override gearboxes, as MO gearboxes already incorporate this function.

### Important

- 1) "Fail open" is factory option.
- 2) When assembled for "fail open" operation (code D; see data sheet A1.504), both stop-screws (1) and (2) will adjust the closed position. There is no adjustment for the open position!

Dim. in inch.	Actuator type									
	E25	E40	E65	E100	E150	E200	E350	E600	E950	E1600
A DA	6.26	7.09	7.83	8.70	10.00	11.14	12.01	15.35	17.32	20.47
B SR	6.77	8.03	9.80	10.51	12.20	14.17	15.24	18.90	20.94	25.24
C	3.15	3.66	4.13	4.65	5.51	5.63	7.13	8.66	10.20	11.69
D	0.79	0.79	0.79	0.79	0.79	0.79	0.79	1.18	1.18	1.18
H	2.91	3.39	3.86	4.25	4.76	5.04	6.81	8.15	9.09	264.00
I	1.81	2.01	2.26	2.48	2.76	2.87	3.71	4.45	4.96	5.59
J1	1.11	1.38	1.57	1.72	1.92	2.12	2.85	3.50	4.03	4.50
L	0.45	0.61	0.61	0.73	0.97	0.97	0.97	1.63	1.63	1.87
Y	1/4"-20	5/16"-18	5/16"-19	3/8"-16	3/8"-16	1/2"-13	1/2"-13	5/8"-11	5/8"-11	3/4"-10
X	1.42	1.63	1.63	1.99	2.36	2.46	2.85	4.02	4.02	4.31
X max.	1.63	1.91	1.91	2.30	2.64	2.91	3.31	4.51	4.51	4.88

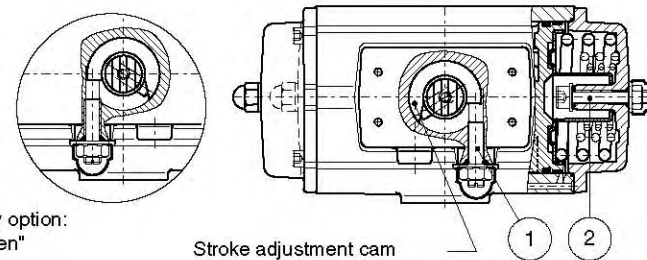

**EL-O-MATIC™**

www.El-O-matic.com

Copyright © Emerson Process Management. The information in this document is subject to change without notice.

Updated data sheets can be obtained from our website [www.El-O-Matic.com](http://www.El-O-Matic.com) or from your nearest Valve Automation Center **USA:** +1 813 319 0266 **Europe:** +31 74 256 10 10 **Asia-Pacific:** +65 6501 4600

**EMERSON**  
Process Management

# Data sheet

Sheet No.: A1.103.106 Rev. D  
Date: May 2011

## DIMENSION SHEET STANDARD ACTUATOR - ISO

E/P

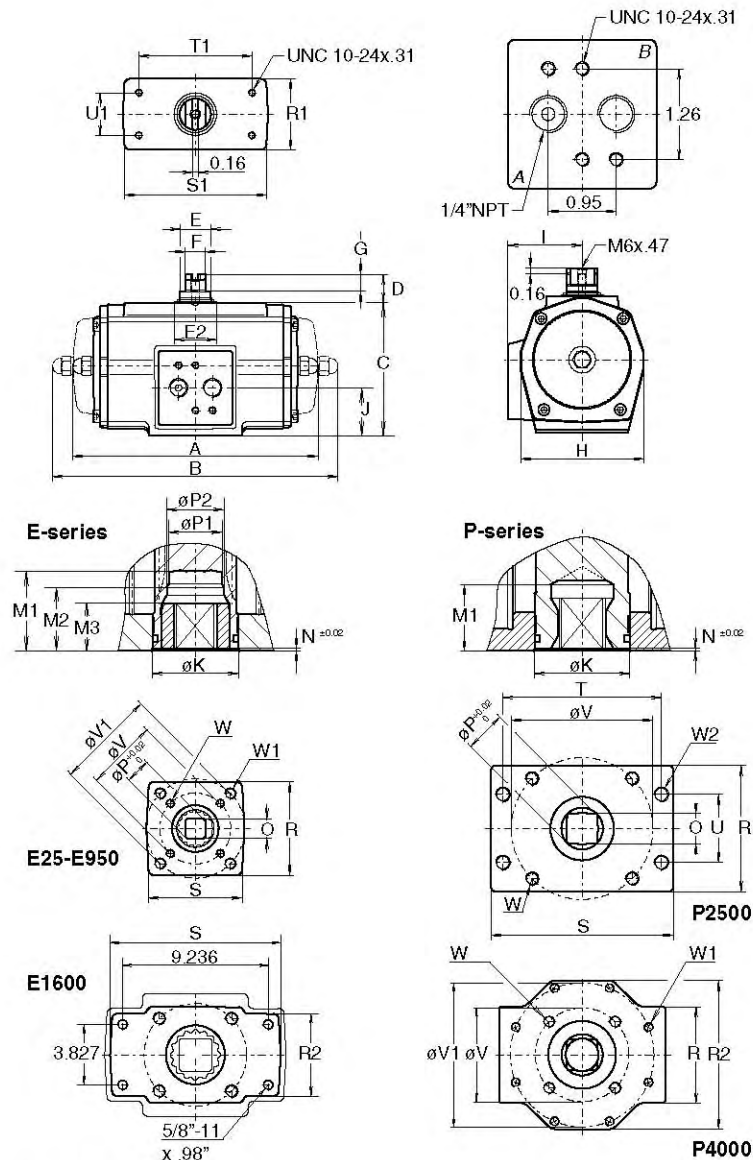

Dim. in inch	Actuators E-series										P-series	
	E 12	E 25	E 40	E 65	E100	E150	E200	E 350	E600	E950	E1600	P2500
A DA	6.26	7.09	7.83	8.70	10.00	11.14	12.01	15.24	16.69	20.31	14.88	19.76
B SR	6.77	8.03	9.80	10.51	12.20	14.17	15.24	18.78	20.35	25.08	22.44	32.83
C	3.15	3.66	4.13	4.65	5.51	5.63	7.13	8.66	10.20	11.69	14.02	14.96
D	0.79	0.79	0.79	0.79	0.79	0.79	0.79	1.18	1.18	1.18	1.18	1.18
E	0.63	0.87	0.87	0.87	1.42	1.42	1.42	2.17	2.17	2.52	2.17	2.52
E2	0.91	1.18	1.18	1.18	1.77	1.77	1.77	2.56	2.56	2.95	2.56	3.15
F	0.39	0.55	0.55	0.55	0.75	0.75	0.75	1.42	1.42	1.42	1.42	1.42
G	0.47	0.47	0.47	0.47	0.47	0.47	0.47	0.39	0.39	0.39	0.39	0.39
H	2.91	3.39	3.86	4.25	4.76	5.04	6.81	8.15	9.09	10.43	13.78	14.96
I	1.81	2.09	2.26	2.48	2.76	2.87	3.71	4.45	4.96	5.59	7.28	7.87
J	1.26	1.32	1.54	1.59	1.59	1.99	2.85	3.33	4.15	4.74	7.01	7.48
K	0.94	1.30	1.30	1.50	2.17	2.17	2.17	2.68	2.95	3.74	3.35	4.72
M1	1.36	1.36	1.36	1.36	1.97	1.97	1.97	2.05	2.52	3.23	2.60	3.03
M2	-	-	-	1.06	-	1.46	1.46	-	-	-	-	-
M3	0.669	0.669	0.669	0.787	0.787	1.161	1.161	1.161	1.949	2.303	-	-
N	0.04	0.04	0.04	0.06	0.04	0.06	0.06	0.06	0.06	0.06	0.12	0.06
O max.	0.437	0.556	0.556	0.753	0.871	0.871	1.068	1.068	1.424	1.817	1.817	2.173
O min.	0.433	0.551	0.551	0.748	0.866	0.866	1.063	1.063	1.417	1.811	1.811	2.165
P	0.555	0.713	0.713	0.992	1.110	1.110	1.425	1.425	1.898	2.370	2.370	2.843
P1	0.555	0.713	0.831	0.909	1.303	1.303	1.303	1.437	1.909	2.382	-	-
P2	-	-	-	0.988	1.264	1.264	1.264	-	-	-	-	-
R	2.05	2.56	2.76	2.76	3.39	3.54	4.49	4.88	5.12	6.06	6.69	6.69
R1	1.97	1.97	1.97	2.36	2.36	2.36	2.36	3.54	3.54	4.92	6.30	6.30
R2	-	-	-	-	-	-	-	-	-	5.20	-	10.31
S	2.05	2.56	2.76	2.76	3.62	3.54	4.49	4.88	5.59	11.02	11.42	11.42
S1	3.94	3.94	3.94	3.94	3.94	3.94	3.94	6.69	6.69	8.27	9.65	9.65
T1	3.150	3.150	3.150	3.150	3.150	3.150	3.150	5.118	5.118	5.118	5.118	5.118
U1	1.181	1.181	1.181	1.181	1.181	1.181	1.181	1.181	1.181	1.181	1.181	1.181
F03	F05	F05	F05	F05	F07	F07	F07	F10	F10	F16	F16	F16
V	1.417	1.969	1.969	1.969	2.756	2.756	2.756	4.016	4.016	6.496	6.496	6.496
W	10-24 x.31"	1/4"-20 x.39"	1/4"-20 x.39"	1/4"-20 x.39"	5/16"-18 x.39"	5/16"-18 x.39"	5/16"-18 x.39"	3/8"-16 x.63"	3/8"-16 x.63"	3/4"-10 x1.14"	3/4"-10 x1.14"	3/4"-10 x1.14"
V1	1.969	2.756	2.756	2.756	4.016	4.016	4.016	4.921	5.512	-	-	10.000
W1	1/4"-20 x.39"	5/16"-18 x.39"	5/16"-18 x.39"	5/16"-18 x.39"	3/8"-16 x.63"	3/8"-16 x.63"	3/8"-16 x.63"	1/2"-13 x.79"	5/8"-11 x.98"	-	-	5/8"-11 x.98"

For E12 dimensions see data sheet A1.103.102

- Note**
1. Flange and square drive to ISO 5211
  2. Top and solenoid flange to VDI/DE 3845 (NAMUR)
  3. For P-series actuators with limit stops see A1.501.01



www.El-O-matic.com

Copyright © Emerson Process Management. The information in this document is subject to change without notice.

Updated data sheets can be obtained from our website [www.El-O-Matic.com](http://www.El-O-Matic.com) or from your nearest Valve Automation Center **USA:** +1 813 319 0266 **Europe:** +31 74 256 10 10 **Asia-Pacific:** +65 6501 4600



**EMERSON**  
Process Management

# Data sheet

Sheet No.: A1.103.102 Rev. A  
Date: November 2009

## DIMENSION SHEET ACTUATOR ISO E12 (90°/180°)

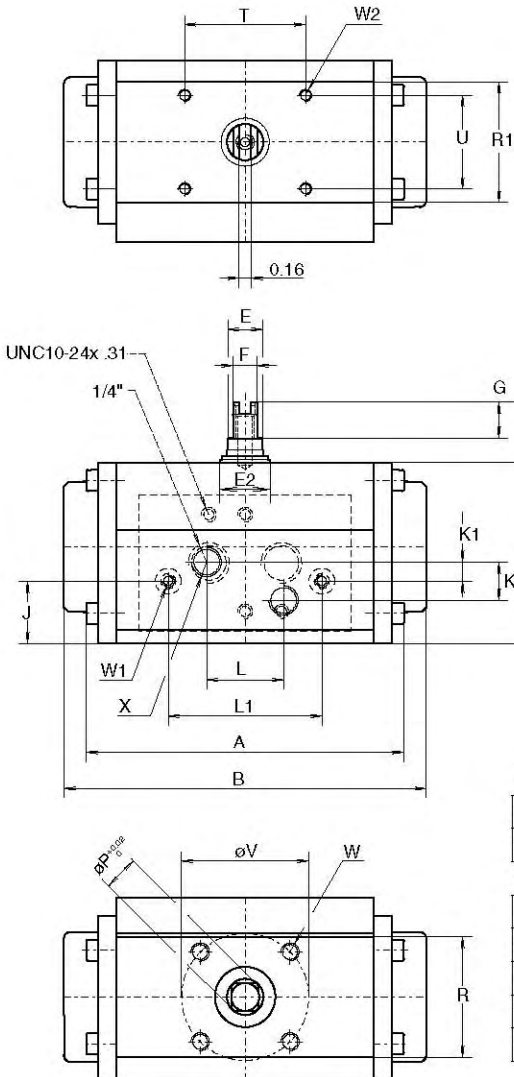

### DOUBLE ACTING TORQUE (ED)

Pressure	psi	40	50	60	70	80	90	100	120
Torque 90°/180°	(in.lb.)	59	74	89	104	119	134	149	179

### SINGLE ACTING TORQUE (ES)

Pressure	psi	Air stroke						Spring stroke	
		60		80		100		start	end
Position	-	start	end	start	end	start	end	start	end
Torque 90°	(in.lb.)	48	23	80	55	112	87	64	41
Torque 180°	(in.lb.)	49	25	81	57	112	88	63	40

Dim. in Inches	90°	180°
A ED	4.06	6.10
B ES	4.65	8.50
C	2.36	2.36
D	0.79	0.79
E	0.63	0.63
E2	0.91	0.91
F	0.39	0.39
G	0.47	0.47
H	2.36	2.36
I	1.30	1.30
J	0.83	0.83
K	0.50	0.50
K1	0.25	0.25
L	1.00	1.00
L1	2.00	2.00
M	0.65	0.65
N	0.039	0.039
Omax.	0.358	0.358
Omin.	0.354	0.354
P	0.476	0.476
R	1.57	1.57
R1	1.57	1.57
T	1.57	1.57
U	1.22	1.22
V	1.654	1.654
W	10-24 UNCx.24"	10-24 UNCx.24"
W1	10-24 UNCx.24"	10-24 UNCx.24"
W2	10-24 UNCx.24"	10-24 UNCx.24"
X	1/8"NPT	1/8"NPT
Y	M6x.48	M6x.48



www.El-O-matic.com

Copyright © Emerson Process Management. The information in this document is subject to change without notice.

Updated data sheets can be obtained from our website [www.El-O-Matic.com](http://www.El-O-Matic.com) or from your nearest Valve Automation Center **USA:** +1 813 319 0266 **Europe:** +31 74 256 10 10 **Asia-Pacific:** +65 6501 4600





# Data sheet

Sheet No.: A1.103.200 Rev. B  
Date: May 2011

## DRIVE INSERTS FOR EL-O-MATIC ACTUATORS

E

### Standard available insert shapes

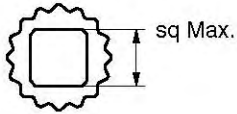

### Optional available insert shapes

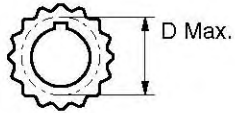
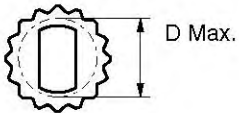

### Insert mounting acc. ISO 5211

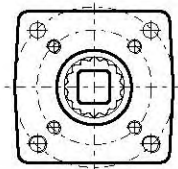
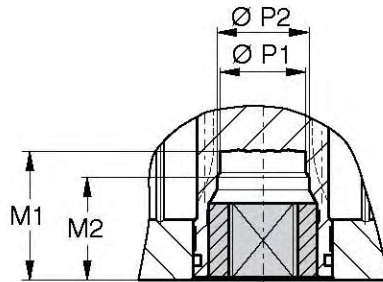

### Description

Most of the EI-O-Matic actuators are fitted with drive inserts. This enables actuators to be directly mounted onto suitable valves and eliminates the need for a bracket and coupling type mounting kit. The use of direct mounts significantly cuts the cost of the valve/actuator assembly.

Standard actuators are fitted with square drive inserts in accordance with ISO 5211 (or DIN 3337), but a wide variety of other inserts are also available. Special inserts may have oversize or undersize squares, double-D and shaft key way forms.

Drive inserts can be supplied on factory built actuators or as loose items and are easily replaceable at distributor or end user level.

Where direct mounts are not possible, for instance on valves with exposed grand packing, the use of inserts often simplifies the design of the mounting kit.

Material : Aluminum alloy  
Finish : Anodized

The following actuator types do not have inserts.

- E12,
- P2500 and P4000
- 180° actuators

These actuators have inner square directly in the bottom of the pinion. See the following data sheets for more information :

E12	ISO5211	A1.103.102
P2500/P4000	ISO 5211	A1.103.106
180°	ISO 5211	A1.203.011

Standard inserts with inner-square-dimensions per actuator type									
	E25	E40 / E65	E100	E150	E200	E350	E600	E950	E1600
	0.433	0.551	0.748	0.866	0.866	1.063	1.063	1.417	1.811
Optional insert dimensions									
	0.354	0.394	0.472	0.551	0.551	0.551	0.551	0.866	
	0.394	0.472	0.551	0.630	0.630	0.630	0.630		
			0.63	0.669	0.669	0.669	0.669		
			0.748	0.748	0.748	0.748	0.748		
			0.945	0.945	0.866	0.866			
			1.063	1.063	0.945	0.945			
Maximum insert dimensions									
M1	1.36	1.36	1.36	1.97	1.97	1.97	2.05	2.52	3.23
M2	-	-	1.06	1.46	1.46	1.46	-	-	-
P1	0.71	0.71	0.91	1.26	1.26	1.26	1.44	1.91	2.38
P2	-	-	0.99	1.43	1.43	1.43	-	-	-
SQ max.	0.630	0.630	0.748	1.063	1.063	1.063	1.063	1.417	1.811
D max.	0.827	0.827	0.929	1.323	1.323	1.323	1.323	1.772	2.362



www.El-O-matic.com

Copyright © Emerson Process Management. The information in this document is subject to change without notice.

Updated data sheets can be obtained from our website [www.El-O-Matic.com](http://www.El-O-Matic.com) or from your nearest Valve Automation Center **USA:** +1 813 319 0266 **Europe:** +31 74 256 10 10 **Asia-Pacific:** +65 6501 4600



# Data sheet

Sheet No.: A1.104.01 Rev. B  
Date: January 2010

## DOUBLE ACTING ACTUATOR TORQUE (In.lb.)

90°

### DOUBLE ACTING TORQUE

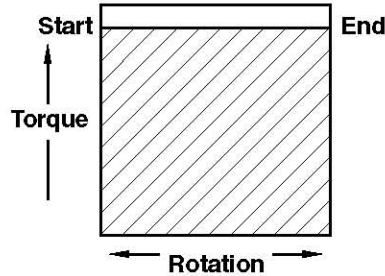

Actuator		Torque of double acting actuators (in In.lb.) Supply pressure (psi)												
Type	Size	30	35	40	45	50	55	60	70	75	80	90	100	120
ED	12	43.9	51.4	58.9	66.4	73.9	81.4	88.9	104	111	119	134	149	179
ED	25	81.4	95.3	109	123	137	151	165	193	206	220	248	276	332
ED	40	153	179	205	231	257	283	309	361	387	413	466	518	622
ED	65	233	272	312	352	392	431	471	551	590	630	709	789	948
ED	100	344	402	461	520	578	637	696	813	872	930	1048	1165	1400
ED	150	551	645	739	833	927	1021	1115	1303	1397	1491	1680	1868	2244
ED	200	754	883	1011	1140	1269	1398	1527	1784	1913	2042	2299	2557	3072
ED	350	1310	1534	1757	1981	2205	2428	2652	3100	3323	3547	3994	4442	5337
ED	600	2226	2606	2986	3366	3747	4127	4507	5267	5647	6028	6788	7548	9069
ED	950	3323	3890	4458	5025	5593	6160	6728	7862	8430	8997	10132	11267	13537
ED	1600	5493	6431	7369	8307	9245	10183	11121	12998	13936	14874	16750	18626	22379
PD	2500	8774	10273	11825	13270	14768	16267	17847	20858	22363	23869	26880	29891	35912
PD	4000	14874	17414	19962	22495	25035	27576	30127	35210	37751	40293	45375	50458	60623

### Note

- Emerson Process Management recommends that the valve manufacturer supply the maximum required torque values (Including any adjustments or suggested safety factors for valve service conditions or application). Additionally, the valve manufacturer must identify at which position(s) and direction(s) of rotation (Counter Clock Wise or Clock Wise) these maximum requirements occur.
- If in doubt, or you require any assistance with sizing actuators, do not hesitate to contact your nearest Emerson's Valve Automation Division representative.
- Pressure on port "A" opens the actuator\*
- The actuator is shown in closed position\*

(\* code A, data sheet A1.503)

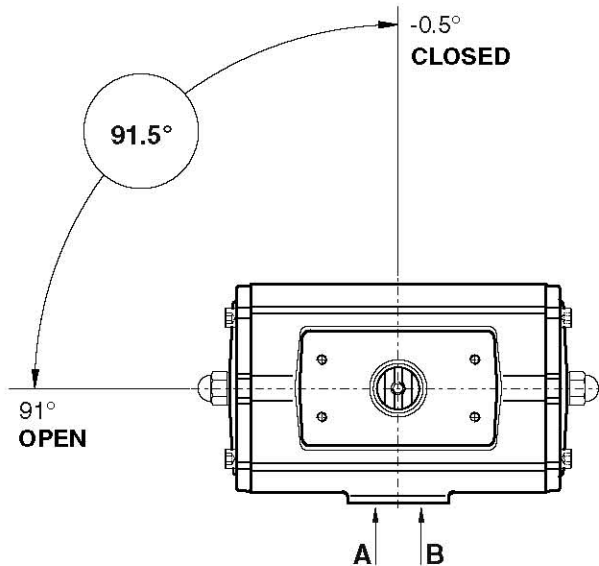

www.El-O-matic.com

Copyright © Emerson Process Management. The information in this document is subject to change without notice.

Updated data sheets can be obtained from our website [www.El-O-Matic.com](http://www.El-O-Matic.com) or from your nearest Valve Automation Center **USA:** +1 813 319 0266 **Europe:** +31 74 256 10 10 **Asia-Pacific:** +65 6501 4600



**EMERSON**  
Process Management

# Data sheet

Sheet No.: A1.104.02 Rev. B  
Date: January 2010

## SPRING RETURN ACTUATOR TORQUE (In.lb.)

90°

### SINGLE ACTING TORQUE

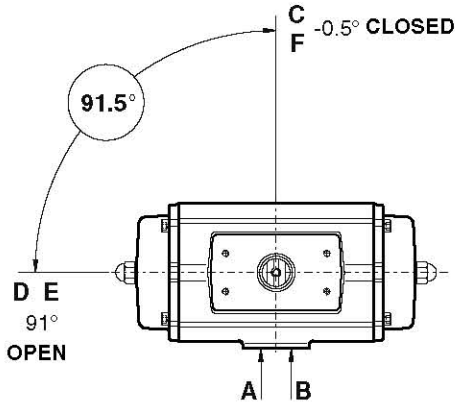
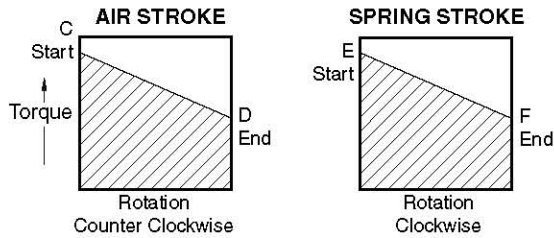

### Note

1. Emerson Process Management recommends that the valve manufacturer supply the maximum required torque values (Including any adjustments or suggested safety factors for valve service conditions or application). Additionally, the valve manufacturer must identify at which position(s) and direction(s) of rotation (Counter Clock Wise or Clock Wise) these maximum requirements occur.
2. If in doubt, or you require any assistance with sizing actuators, do not hesitate to contact your nearest Emerson's Valve Automation Division representative.
3. Pressure on port "A" opens the actuator\*
4. The actuator is shown in closed position\* (\* code A, data sheet A1.504)

Actuator Type	Springset nr.	Air Stroke (lb/in)												Spring Stroke (lb/in)	
		SUPPLY PRESSURE (in PSI)													
		40		60		80		100		120		E	F		
PS 2500	6	6981	4278	12875	10273	18969	16267	24963	22261	30858	28255	7013	4401		
	8	5251	1781	11245	7775	17239	13769	23233	19764	29228	25758	9351	5868		
	10	-	-	9615	5278	15609	11272	21603	17266	27597	23260	11689	7335		
	12	-	-	7985	2780	13979	8774	19973	14768	25967	20763	14026	8803		
	14	-	-	-	-	12349	6277	18343	12271	24337	18265	16364	10270		
PS 4000	6	11701	7310	21862	17472	32024	27633	42185	37795	52347	47956	11835	7429		
	8	8949	3096	19111	13257	29272	23419	39434	33580	49595	43742	15780	9905		
	10	-	-	16359	9042	26521	19204	36682	29365	46844	39527	19725	12381		
	12	-	-	13608	4828	23770	14989	33931	25150	44093	35312	23670	14857		
	14	-	-	-	-	21018	10774	31180	20936	41341	31097	27615	17333		

Actuator Type	Springset nr.	Air Stroke (lb/in)												Spring Stroke (lb/in)		
		SUPPLY PRESSURE (in PSI)														
		40		60		80		100		120		E	F			
ES 12	2	-	-	48	24	80	55	111	87	143	119	63	40			
	ES 25	2	71	44	130	103	189	162	248	221	306	280	62	39		
		3	48	8	107	67	166	126	225	185	284	244	94	59		
		4	-	-	85	31	144	90	203	149	262	208	125	78		
		5	-	-	-	-	121	54	180	113	239	172	156	98		
		6	-	-	-	-	99	18	158	77	217	136	188	117		
ES 40	2	133	82	243	193	354	303	464	414	575	524	117	73			
	3	91	15	201	125	312	236	422	346	533	457	176	110			
	4	-	-	159	58	270	169	380	279	491	390	234	146			
	5	-	-	-	-	228	101	338	212	449	322	293	183			
	6	-	-	-	-	185	34	296	144	406	255	351	220			
	ES 65	2	196	117	365	285	533	454	701	622	870	790	186	117		
3		129	10	297	178	466	347	634	515	802	683	279	176			
4		-	-	230	71	398	240	567	408	735	576	372	234			
5		-	-	-	-	331	133	500	301	668	470	465	292			
6		-	-	-	-	264	26	432	194	601	363	558	351			
ES 100		2	303	192	552	441	801	690	1050	939	1299	1188	258	161		
	3	211	44	460	293	709	542	958	791	1206	1039	387	242			
	4	-	-	367	144	616	393	865	642	1114	891	516	323			
	5	-	-	-	-	523	245	772	494	1021	743	646	403			
	6	-	-	-	-	430	96	679	345	928	594	775	484			
	ES 150	2	485	297	884	696	1283	1094	1681	1493	2090	1892	423	259		
3		337	54	735	453	1134	852	1533	1250	1931	1649	634	398			
4		-	-	587	210	985	609	1384	1007	1783	1406	845	517			
5		-	-	-	-	837	366	1235	764	1634	1163	1056	647			
6		-	-	-	-	688	123	1087	522	1485	920	1268	776			
ES 200		2	656	406	1202	952	1747	1498	2293	2043	2838	2589	579	362		
	3	448	74	994	619	1539	1165	2085	1710	2631	2256	868	542			
	4	-	-	786	287	1332	832	1877	1378	2423	1924	1158	723			
	5	-	-	-	-	1124	500	1669	1045	2215	1591	1447	904			
	6	-	-	-	-	916	167	1462	713	2007	1258	1736	1085			
	ES 350	2	1105	684	2053	1632	3001	2580	3949	3528	4897	4476	1025	658		
3		727	95	1675	1043	2623	1991	3571	2939	4519	3887	1537	987			
4		-	-	1297	455	2245	1403	3193	2351	4141	3299	2049	1317			
5		-	-	-	-	1866	814	2814	1762	3762	2710	2561	1646			
6		-	-	-	-	1488	225	2436	1173	3384	2121	3074	1975			
ES 600		2	1920	1183	3531	2794	5142	4405	6753	6016	8364	7628	1723	1082		
	3	1298	193	2909	1804	4520	3415	6131	5026	7742	6637	2585	1624			
	4	-	-	2287	814	3898	2425	5509	4036	7120	5647	3446	2165			
	5	-	-	-	-	3276	1434	4887	3046	6498	4657	4308	2706			
	6	-	-	-	-	2654	444	4265	2055	5876	3666	5169	3247			
	ES 950	2	2898	1777	5303	4182	7708	6587	10113	8992	12518	11397	2563	1587		
3		1986	304	4391	2709	6796	5114	9201	7519	11606	9924	3844	2381			
4		-	-	3479	1236	5884	3641	8298	6046	10693	8451	5125	3175			
5		-	-	-	-	4971	2168	7376	4573	9781	6978	6407	3968			
6		-	-	-	-	4059	695	6464	3100	8869	5905	7688	4762			
ES 1600		2	4765	2988	8741	6964	12716	10939	16692	14915	20668	18890	4193	2646		
	3	3244	578	7220	4554	11196	8530	15171	12505	19147	16481	6289	3970			
	4	-	-	5699	2145	9675	6120	13650	10096	17626	14071	8385	5293			
	5	-	-	-	-	8154	3711	12129	7686	16105	11662	10481	6616			
	6	-	-	-	-	6633	1301	10608	5277	14584	9252	12578	7939			



www.El-O-matic.com

Copyright © Emerson Process Management. The information in this document is subject to change without notice.

Updated data sheets can be obtained from our website [www.El-O-Matic.com](http://www.El-O-Matic.com) or from your nearest Valve Automation Center **USA:** +1 813 319 0266 **Europe:** +31 74 256 10 10 **Asia-Pacific:** +65 6501 4600



**EMERSON**  
Process Management



# Data sheet

Sheet No.: A1.101.33 Rev. A  
Date: November 2009

## CONSTRUCTION, PARTS AND MATERIALS E-SERIE ACTUATORS

E

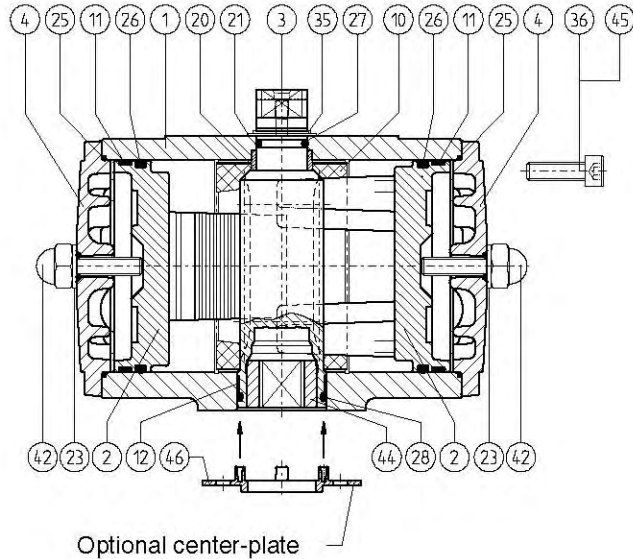

### Notes

- 1 Hard anodized aluminum alloy: AlZnMgCu1.5, DIN 1725/1
- 2 Deltatone Coating
- 3 Anodized
- 4 Zinc plated and passivated
- 5 CSR Coating (see 4.204.02)
- 6 Stainless Steel Sandvic 1802, SS2382
- 7 Stainless Steel X35CrM017
- 8 No insert, adaptor square direct in pinion

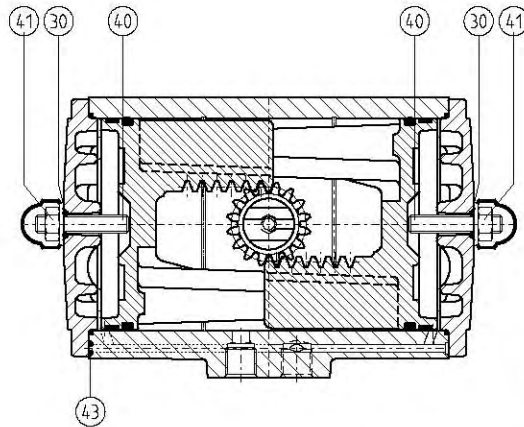

DOUBLE ACTING ED

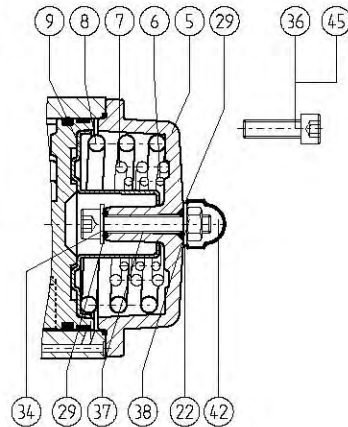

SINGLE ACTING ES

Parts			Materials		Executions		
Nr.	Description	Qty.	Description	Specification	Std	S.S. Shaft	CSR
1	Body	1	Aluminum Alloy	UNS A13600, ASTM B85	-	-	5
2	Piston	2	Aluminum Alloy	UNS A03560, ASTM B26	-	-	-
3	Drive pinion	1	GAISI10Mg, DIN 1725/2	UNS 1 77075, ASTM 7075 T6	1	6	6
4	End Cap ED	2	Aluminum Alloy	UNS A13600, ASTM B85	-	-	5
5	End Cap ES	2	Aluminum Alloy	UNS A13600, ASTM B85	-	-	5
6	Spring- inner	2	Carbon Spring Steel	UNS G10860, ASTM A228	2	2	2
7	Spring- mid	2	Carbon Spring Steel	UNS G10860, ASTM A228	2	2	2
8	Spring- outer	2	Carbon Spring Steel	UNS G10860, ASTM A228	2	2	2
9	Spring Holder	2	Steel	C45, DIN 17200	3	3	3
10	* Guide Band	1	Nylatron	PA6.6 + MoS2	-	-	-
11	* Guide Band	2	PTFE, Carbon filled	PTFE + 25% C	-	-	-
12	* Bearing Bush	1	Nylatron	PA6.6 + MoS2	-	-	-
20	* Bearing Bush	1	Delrin	POM	-	-	-
21	* O-ring	1	Nitrile Rubber	Buna N	-	-	-
22	* Washer ES	2	Nylon	PA6	-	-	-
23	* Washer ED	2	Nylon	PA6	-	-	-
25	* O-ring	2	Nitrile Rubber	Buna N	-	-	-
26	* O-ring	2	Nitrile Rubber	Buna N	-	-	-
27	* Washer	1	ZEDEX 100 K	-	-	-	-
28	* O-ring	1	Nitrile Rubber	Buna N	-	-	-
29	* O-ring	4	Nitrile Rubber	Buna N	-	-	-
30	* O-ring	2	Nitrile Rubber	Buna N	-	-	-
34	Washer ES	2	Steel	C35	3	3	3
35	* Spring Clip	1	Carbon Spring Steel	MIL - R-212 48B	2	7	7
36	End Cap Bolt ED/ES	8	Stainless Steel	AISI 304	-	-	-
37	Limit Stop Bolt ES	2	Stainless Steel	AISI 304	-	-	-
38	Nut	2	Stainless Steel	AISI 304	-	-	-
40	Limit Stop Bolt ED	2	Stainless Steel	AISI 304	-	-	-
41	Nut	2	Stainless Steel	AISI 304	-	-	-
42	Nut Cover	2	Polyethylene	PE	-	-	-
43	* O-ring	2	Nitrile Rubber	Buna N	-	-	-
44	Insert	1	Aluminum Alloy	UNS 1 6082, ASTM 6082	4	9	4
45	Threaded insert	8	Steel	UNS G10430, ASTM A29	3	3	3

\* Recommended spare parts (contained in Repair kits)

### Remark

All materials are European origin, listed are the nearest US equivalents.

### Finish

Standard : Polyester non-TGIC based powder coating  
(see data sheet A4.204.01)

CSR : CSR Coating (see data sheet A4.204.02)

**EL-O-MATIC™**

www.El-O-matic.com

Copyright © Emerson Process Management. The information in this document is subject to change without notice.

Updated data sheets can be obtained from our website [www.El-O-Matic.com](http://www.El-O-Matic.com) or from your nearest Valve Automation Center **USA:** +1 813 319 0266 **Europe:** +31 74 256 10 10 **Asia-Pacific:** +65 6501 4600



**EMERSON**  
Process Management

# Data sheet

Sheet No.: A1.101.30 Rev. A  
Date: November 2009

## CONSTRUCTION, PARTS AND MATERIALS P-SERIE ACTUATORS

P

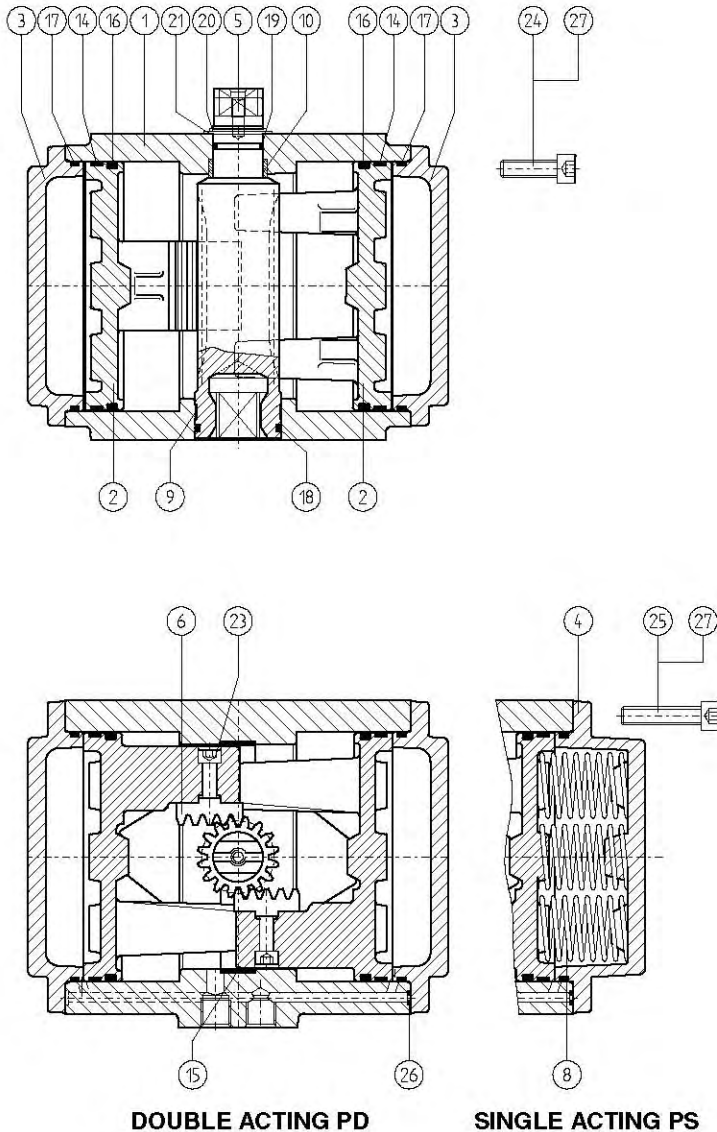

Parts			Materials		Executions		
Nr.	Description	Qty.	Description	Specification	Std	S.S. Shaft	CSR
1	Body	1	Aluminum Alloy	UNS A13600, ASTM B85	-	-	6
2	Piston	2	Aluminum Alloy	UNS A03560, ASTM B26	-	-	-
3	Endcap PDA	2	Aluminum Alloy	UNS A13600, ASTM B85	-	-	6
4	Endcap PSA	2	Aluminum Alloy	UNS A13600, ASTM B85	-	-	6
5	Drive pinion	1	Aluminum Alloy	UNS 1 77075, ASTM 7075 T6	1	4	4
6	Gear Rack	2	Steel	UNS G10950, ASTM A108	-	-	-
8	Spring	14	Carbon Spring Steel	UNS G10860, ASTM A228	2	2	2
9	* Bearing Bush	1	Nylatron GS	PA6.6 + MoS2	-	-	-
10	* Bearing Bush	1	Delrin	POM	-	-	-
14	* Guide band	2	PTFE, Carbon filled	PTFE + 25% C	-	-	-
15	* Guide band	2	PTFE, Carbon filled	PTFE + 25% C	-	-	-
16	* O-ring	2	Nitrile Rubber	Buna N	-	-	-
17	* O-ring	2	Nitrile Rubber	Buna N	-	-	-
18	* O-ring	1	Nitrile Rubber	Buna N	-	-	-
19	* O-ring	1	Nitrile Rubber	Buna N	-	-	-
20	* Spring Clip	1	Carbon Spring Steel	MIL - R-212 48B	2	5	5
21	* Thrust Washer	1	ZEDEX 100 K	-	-	-	-
23	Bolt	4	Alloy Steel	12.9 ASTM F568	-	-	-
24	Endcap bolt PDA	20	Alloy Steel	8.8 ASTM F568	2	4	4
25	Endcap bolt PSA	20	Alloy Steel	8.8 ASTM F568	2	4	4
26	* O-ring	2	Nitrile Rubber	Buna N	-	-	-
27	Threaded insert	20	Steel	UNS G10430, ASTM A29	3	3	3

\* Recommended spare parts (contained in Repair kit)

### Notes

- 1 Hard anodized
- 2 Deltatone® Coating
- 3 Zinc plated and passivated
- 4 Stainless Steel AISI 304
- 5 Stainless Steel, X35CrM017
- 6 CSR Coating (see A4.204.02)
- 7 P4000 has a stainless steel (AISI 304) locking ring between spring clip (20) and thrust washer (21)
- 8 P4000 has in the springs a guiding bush (PVC)

### Remark

All materials are European origin, listed are the nearest US equivalents

### Finish

- Standard : Polyester non-TGIC based powder coating (see data sheet A4.204.01)
- CSR : CSR Coating (see data sheet A4.204.02)

**EL-O-MATIC™**

www.El-O-matic.com

Copyright © Emerson Process Management. The information in this document is subject to change without notice.

Updated data sheets can be obtained from our website [www.El-O-Matic.com](http://www.El-O-Matic.com) or from your nearest Valve Automation Center **USA:** +1 813 319 0266 **Europe:** +31 74 256 10 10 **Asia-Pacific:** +65 6501 4600

**EMERSON**  
Process Management

## Data sheet

Sheet No.: A1.101.60 Rev. A  
Date: November 2009

# CONSTRUCTION, PARTS AND MATERIALS DSA ACTUATOR

DSA

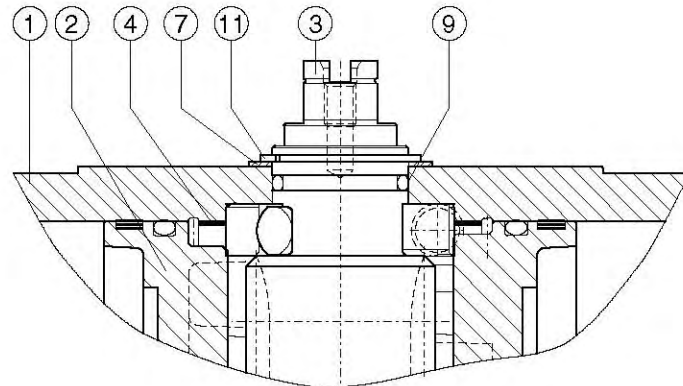
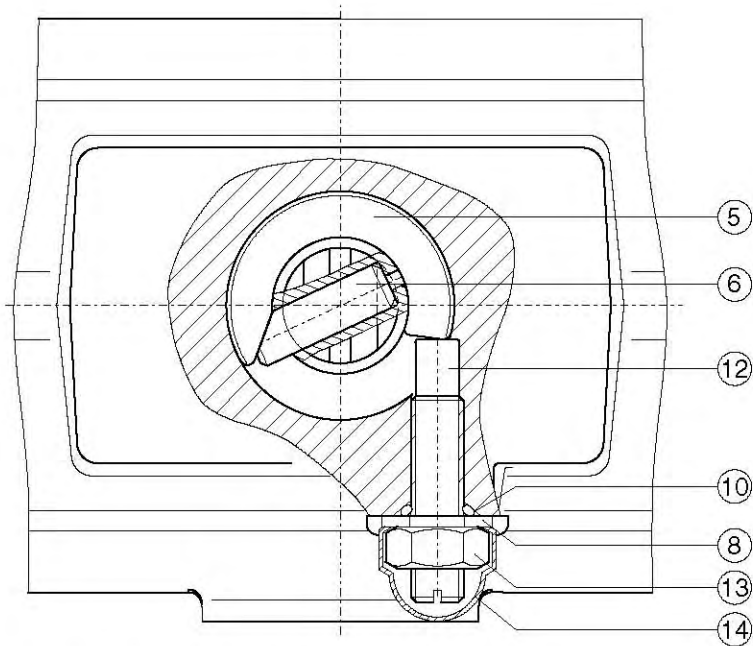

Nr.	Description	Qty.	Material	Specification	Note
1	Body DSA	1	Aluminum Alloy	UNS A13600, ASTM B85	-
2	Piston DSA	2	Aluminum Alloy	UNS A03560, ASTM B26	-
3	Drive pinion DSA	1	Aluminum Alloy	UNS 1 77075, ASTM 7075 T6	1
4	* Guide Band DSA	1	Nylatron GS	UNS A13600, ASTM B85	-
5	Cam for stroke adj. DSA	1	Stainless Steel	UNS A13600, ASTM B85	-
6	Shaftpin for stroke adj. DSA	1	Chrome nickel steel	UNS G10860, ASTM A228	-
7	* Washer	1	ZEDEX 100 K	-	-
8	* Washer	1	Nylon	UNS G10860, ASTM A228	-
9	* O-ring shaft top	1	Nitrile Rubber	C45, DIN 17200	-
10	* O-ring limit stop bolt DSA	1	Nitrile Rubber	PA6.6 + MoS2	-
11	Circlip	1	Carbon spring steel	PTFE + 25% C	2
12	Limitstop bolt DSA	1	Stainless Steel	PA6.6 + MoS2	-
13	Nut	1	Stainless Steel	POM	-
14	Nut Cover	1	Polyethylene	Buna N	-

\* Recommended spare parts (contained in Repair kits DSA)

### Finish

Polyester non-TGIC based powder coating (see data sheet A4.204.01)

### Note

- 1 Hard anodized
- 2 Deltatone® coating

### Remark

This data sheet shows only the extra or specific parts of a DSA actuator.  
For all the other parts see data sheet A1.101.33

**EL-O-MATIC™**

www.El-O-matic.com

Copyright © Emerson Process Management. The information in this document is subject to change without notice.

Updated data sheets can be obtained from our website [www.El-O-Matic.com](http://www.El-O-Matic.com) or from your nearest Valve Automation Center **USA:** +1 813 319 0266 **Europe:** +31 74 256 10 10 **Asia-Pacific:** +65 6501 4600

**EMERSON**  
Process Management



## Data sheet

Sheet No.: A1.101.70 Rev. C  
Date: June 2010

# LOW TEMPERATURE ACTUATOR SPECIFICATIONS

-40°C / +80°C

-40°F / +176°F

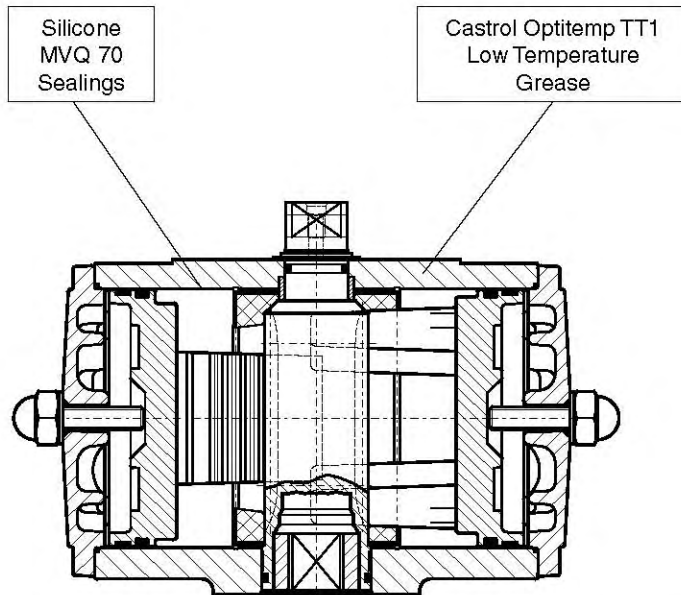

### Description

A double piston, rack and pinion pneumatic actuator incorporating a three point piston support system, anti-blowout spindle and with high duty synthetic bearings at all bearing points.

This version is a standard aluminum actuator, but incorporating parts and materials suitable for low temperature operation.

### Note

When operating actuators in sub-zero temperatures (< 0°C or < 32°F) care should be taken to counter the effects of freezing condensate inside the actuator.

### Specification

Max. pressure : 120 psi (8 bar)

Torque : Standard

Media : Air or non corrosive gas

Temperature : -40°F to +176°F (-40°C to +80°C)

Finish : Polyester non-TGIC based powder coating (see data sheet A4.204.01)

### Spare parts

Dedicated low temperature spare parts are available for maintenance or make a standard actuator suitable for low temperature operation.

Part	Material	Specifications	Remark
<b>Housing</b>	Aluminum Alloy	UNS A13600, ASTM B85	
<b>Drive Shaft</b>	Aluminum Alloy	UNS 1 77075, ASTM 7075 T6	Hard anodized
	Steel (180° rotation)	ETG100 or 42CrMo4V XM	Zinc Plated type > P750
	Stainless Steel	Sandvic 1802, SS2382 or X35CrM017	type > E950
<b>Piston</b>	Aluminum Alloy	UNS A03560, ASTM B26	
<b>Sealings</b>	Silicone MVQ 70 O-rings	-/-	
<b>Grease</b>	Castrol Optitemp TT1	-/-	
<b>Shaft bearings</b>	Top :	Delrin	POM
	Bottom :	Nylatron	PA6.6 + MoS2
<b>Piston bearings</b>	PTFE	25% Carbon filled	
<b>Bodybearings</b>	PTFE	("P" serie)	25% Carbon filled
	Nylatron	("E" serie)	PA6.6 + MoS2
<b>Shaft thrust washer</b>	ZEDEX 100 K	-/-	
<b>End cap bolts</b>	Stainless Steel	("E" serie)	AISI 304 A2
	Alloy Steel	("P" serie)	8.8 DIN 912
<b>Springs</b>	Carbon Spring Steel	UNS G10860, ASTM A228	Deltatone® coating

**EL-O-MATIC™**

www.El-O-matic.com

Copyright © Emerson Process Management. The information in this document is subject to change without notice.

Updated data sheets can be obtained from our website [www.El-O-Matic.com](http://www.El-O-Matic.com) or from your nearest Valve Automation Center **USA:** +1 813 319 0266 **Europe:** +31 74 256 10 10 **Asia-Pacific:** +65 6501 4600



**EMERSON.**  
Process Management

## Data sheet

Sheet No.: A1.101.71 Rev. B

Date: January 2010

# HIGH TEMPERATURE ACTUATOR SPECIFICATIONS

-20°C / +120°C

-4°F / +248°F

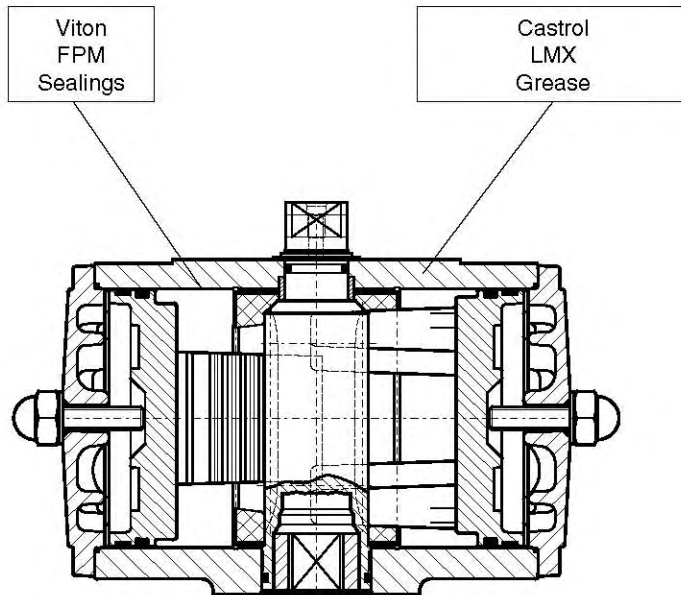

### Description

A double piston, rack and pinion pneumatic actuator incorporating a three point piston support system, anti-blowout spindle and with high duty synthetic bearings at all bearing points.

This version is a standard aluminum actuator, but incorporating parts and materials suitable for high temperature operation.

### Specification

Max. pressure : 8 bar ~ 120psi  
 Torque : Standard  
 Media : Air or non corrosive gas  
 Temperature : -4°F to +248°F (-20°C to +120°C)  
 Finish : Polyester non-TGIC based powder coating (see data sheet A4.204.01)

### Spare parts

Dedicated high temperature spare parts are available for maintenance or make a standard actuator suitable for high temperature operation.

Materials				
Part	Material		Specifications	Remark
Housing	Aluminum Alloy		UNS A13600, ASTM B85	
	Aluminum Alloy		UNS 1 77075, ASTM 7075 T6	Hard anodized
Drive Shaft	Steel (180° rotation)		ETG100 or 42CrMo4V XM	Zinc Plated type > P750
	Stainless Steel		Sandvic 1802, SS2382 or X35CrM017	type > E950
	Aluminum Alloy		UNS A03560, ASTM B26	
Piston	Aluminum Alloy		UNS A03560, ASTM B26	
Sealings	Viton FPM O-rings		-/-	
Grease	Castrol LMX		-/-	
Shaft bearings	Top :	Delrin	POM	
	Bottom :	Nylatron	PA6.6 + MoS2	
Piston bearings	PTFE		25% Carbon filled	
Bodybearings	PTFE	("P" serie)	25% Carbon filled	
	Nylatron	("E" serie)	PA6.6 + MoS2	
Shaft thrust washer	ZEDEX 100 K		-/-	
End cap bolts	Stainless Steel	("E" serie)	AISI 304 A2	
	Alloy Steel	("P" serie)	8.8 DIN 912	Deltatone® coating
Springs	Carbon Spring Steel		UNS G10860, ASTM A228	Deltatone® coating

**EL-O-MATIC™**

www.El-O-matic.com

Copyright © Emerson Process Management. The information in this document is subject to change without notice.

Updated data sheets can be obtained from our website [www.El-O-Matic.com](http://www.El-O-Matic.com) or from your nearest Valve Automation Center **USA:** +1 813 319 0266 **Europe:** +31 74 256 10 10 **Asia-Pacific:** +65 6501 4600



**EMERSON.**  
Process Management

**Data sheet**

Sheet No.: A4.201 Rev.A  
Date: November 2009

**INSTALLATION OF SPRINGS OF P-SERIES ACTUATOR**

**P**

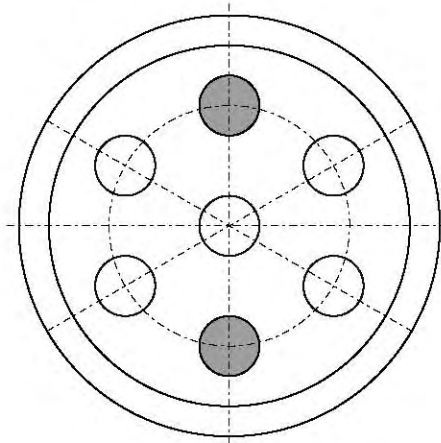

**4 SPRINGS**

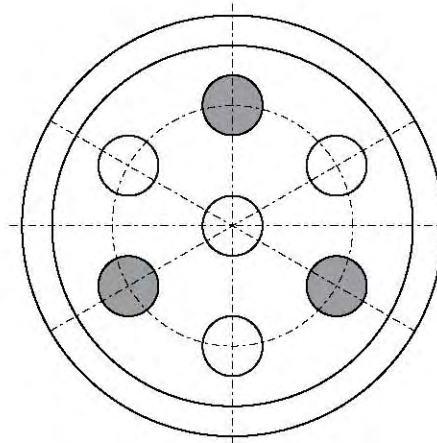

**6 SPRINGS**

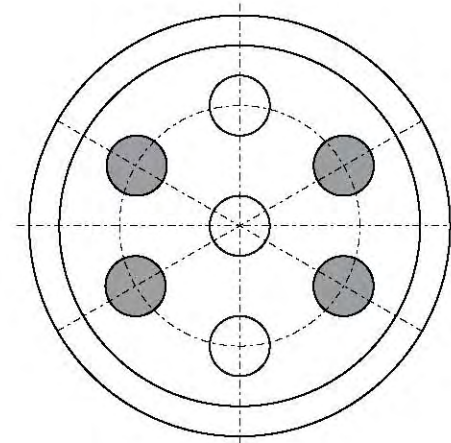

**8 SPRINGS**

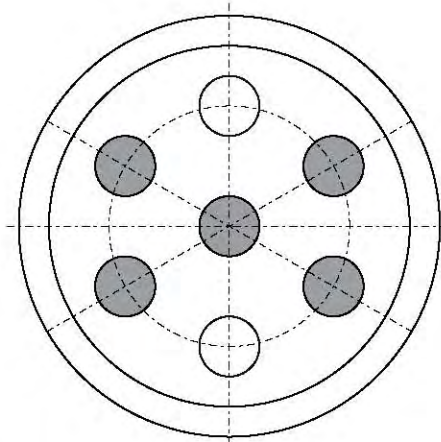

**10 SPRINGS**

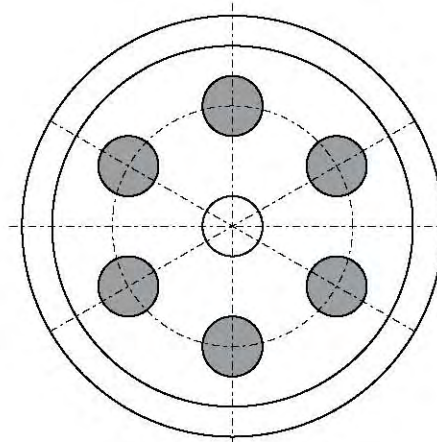

**12 SPRINGS**

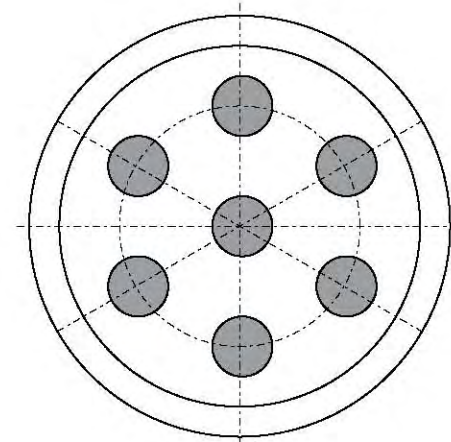

**14 SPRINGS**



[www.El-O-matic.com](http://www.El-O-matic.com)

Copyright © Emerson Process Management. The information in this document is subject to change without notice.

Updated data sheets can be obtained from our website [www.El-O-Matic.com](http://www.El-O-Matic.com) or from your nearest Valve Automation Center **USA:** +1 813 319 0266 **Europe:** +31 74 256 10 10 **Asia-Pacific:** +65 6501 4600



**EMERSON.**  
Process Management



**Data sheet**

Sheet No.: A4.202 Rev.A

Date: November 2009

**INSTALLATION OF SPRINGS OF E-SERIES ACTUATOR**

**E**

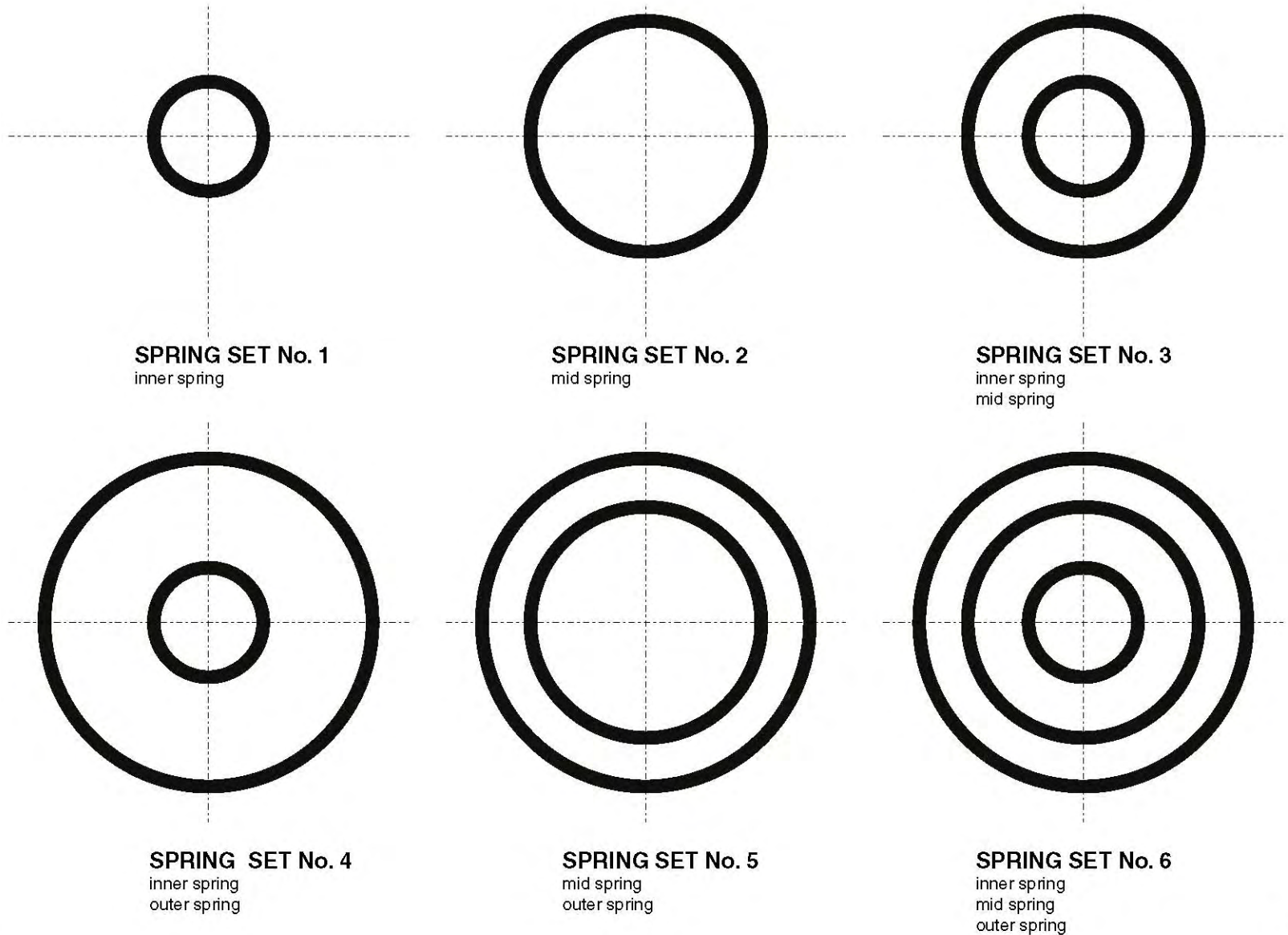

[www.El-O-matic.com](http://www.El-O-matic.com)

Copyright © Emerson Process Management. The information in this document is subject to change without notice.

Updated data sheets can be obtained from our website [www.El-O-Matic.com](http://www.El-O-Matic.com) or from your nearest Valve Automation Center **USA:** +1 813 319 0266 **Europe:** +31 74 256 10 10 **Asia-Pacific:** +65 6501 4600



# Data sheet

Sheet No.: A1.503 Rev. A  
Date: November 2009

## DOUBLE ACTING ACTUATOR ASSEMBLY MODES

E/P

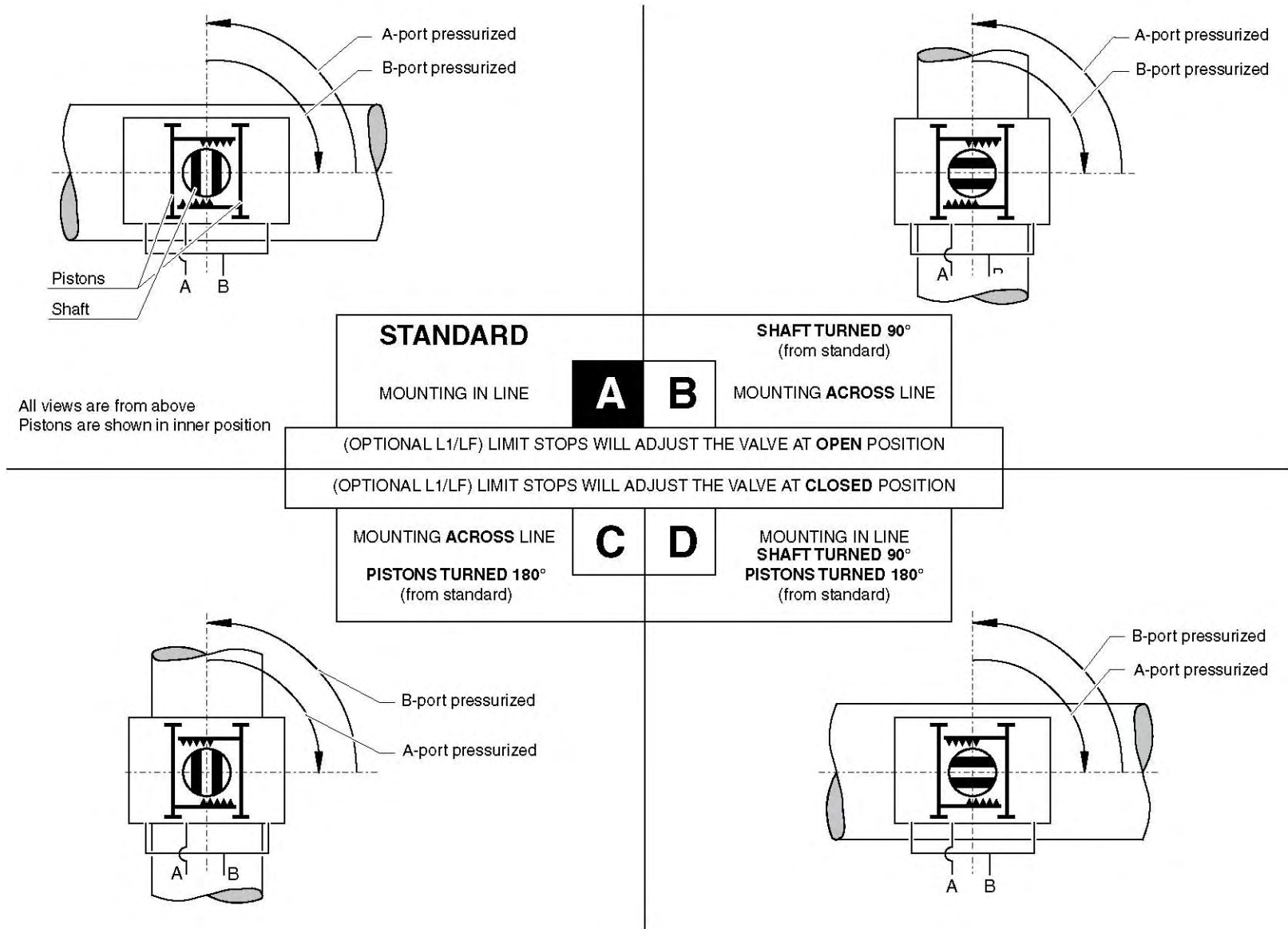

**EL-O-MATIC™**

www.El-O-matic.com

Copyright © Emerson Process Management. The information in this document is subject to change without notice.

Updated data sheets can be obtained from our website [www.El-O-Matic.com](http://www.El-O-Matic.com) or from your nearest Valve Automation Center **USA:** +1 813 319 0266 **Europe:** +31 74 256 10 10 **Asia-Pacific:** +65 6501 4600

**EMERSON**  
Process Management

**Data sheet**

Sheet No.: A1.504 Rev. A  
Date: November 2009

**SPRING RETURN ACTUATOR ASSEMBLY MODES**

**E/P**

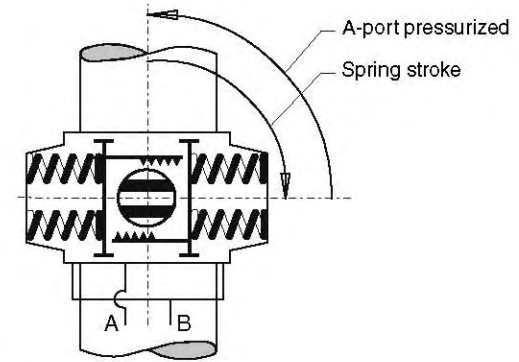
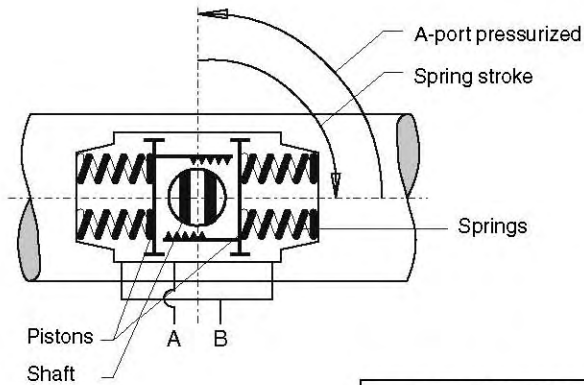

All views are from above  
Pistons are shown in inner position

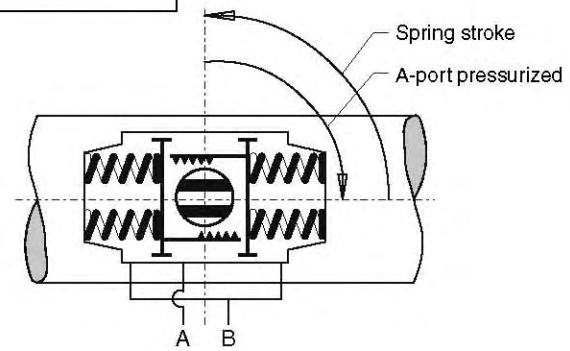
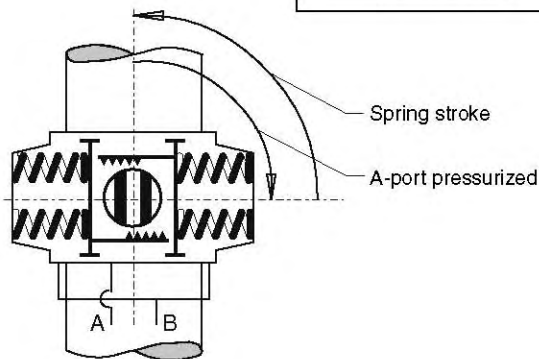
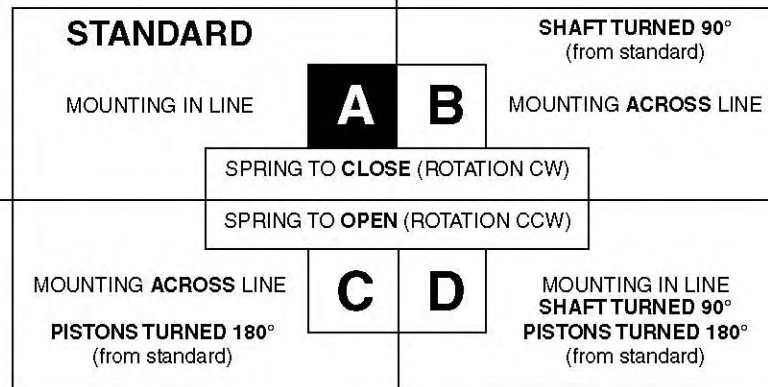

www.El-O-matic.com

Copyright © Emerson Process Management. The information in this document is subject to change without notice.

Updated data sheets can be obtained from our website [www.El-O-Matic.com](http://www.El-O-Matic.com) or from your nearest Valve Automation Center **USA:** +1 813 319 0266 **Europe:** +31 74 256 10 10 **Asia-Pacific:** +65 6501 4600



## Data sheet

Sheet No.: A4.204.01 Rev.B

Date: April 2011

# EL-O-MATIC STANDARD CORROSION PROTECTION SYSTEM

### Description

The corrosion protection system of standard EL-O-Matic E&P series pneumatic actuators consist of the following treatments or materials:

#### 1 De-greasing

All aluminum parts are de-greased before the powder coating is applied by washing with an alkaline solution to assure the best bonding between the aluminum surface and the coating.

#### 2 Powder coating

- Polyester non-TGIC based powder coating for exterior use.
- The powder coating is applied cold using automatic electrostatic spray equipment and is cured at minimum 190°C (374°F) offering excellent anti color fade and weather resistance.
- The powder coating thickness is 1.5 mm (37 microns) minimum, and 2 mm (50 microns) average.
- Good resistance against most chemical bases, acids, solvents, alkalis and oils at normal temperatures.
- Excellent exterior mechanical durability.
- The coating has passed a salt spray test according to ASTM B117 for 500 hours. The powder coating is virtually solvent free, and therefore environmentally friendly.

#### 3 High grade & hard anodized aluminum pinion

Actuators with high grade & hard anodized aluminum pinions, passed a 500 hours salt spray test. Optional stainless steel pinions are available for a higher corrosion resistance.

#### 4 Stainless steel or Deltatone® treated external steel parts

External parts are stainless steel or steel alloy with a Deltatone® treatment.

### Technical data:

Coating	: Polyester non-TGIC based powder coating
Salt spray test	: DIN 50021 / ASTM B117: 500h
Color	: Yellow (RAL 1007)
Materials	: Housing : Aluminum alloy
	: Pinion : High grade aluminum alloy, hard anodized (Option : Stainless steel)
	: Fasteners : Stainless steel or alloy steel with Deltatone® treatment
	: Tagplate : Stainless steel
Application	: Standard EL-O-MATIC E & P series pneumatic actuators For Non-Standard actuators, see data sheet A4.204.05
Option	: CSR coating for excellent corrosion resistance See data sheet A4.204.02

**High grade aluminum alloy,  
hard anodized**  
(Option : Stainless steel)

**Stainless steel fasteners**

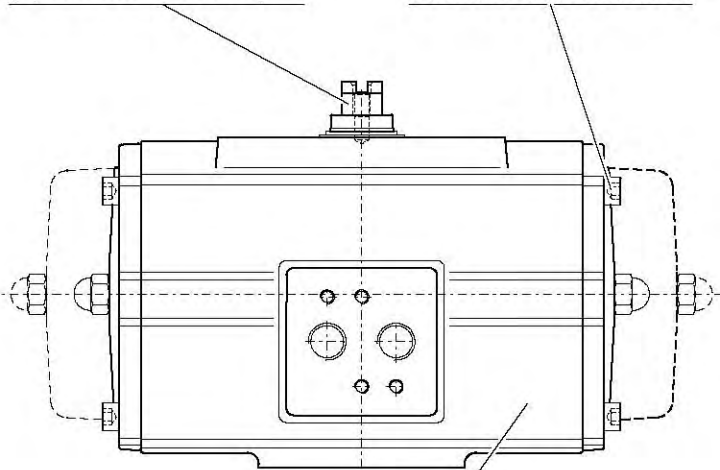

#### **Powder coating:**

Polyester non-TGIC based powder coating for exterior use.

**EL-O-MATIC™**

www.El-O-matic.com

Copyright © Emerson Process Management. The information in this document is subject to change without notice.

Updated data sheets can be obtained from our website [www.El-O-Matic.com](http://www.El-O-Matic.com) or from your nearest Valve Automation Center **USA:** +1 813 319 0266 **Europe:** +31 74 256 10 10 **Asia-Pacific:** +65 6501 4600

  
**EMERSON.**  
Process Management



## Data sheet

Sheet No.: A4.204.02 Rev.B  
Date: June 2009

# EL-O-MATIC ACTUATOR WITH CSR COATING

CSR

### Description

EL-O-MATIC CSR-actuators have an excellent corrosion resistance in environments where the actuator is in contact with chemicals like caustic soda. The CSR coating itself is resistant to at least 1000 hours of salt spray test exposure. Together with the excellent mechanical properties, the CSR coating is "the" solution for very harsh environments.

CSR actuator housing and caps are completely coated (inside and out) with a ceramic filled fluoropolymer based epoxy resin, impregnated by a temperature of 240°C into the aluminum surface.

Approximately 40% of the coating is impregnated into the aluminum, 60% stays on the surface of the component as a seal.

### Technical data

Coating	: Ceramic filled fluoropolymer based epoxy resin
Layer thickness	: 20 microns
Salt spray test	: DIN 50021 / ASTM B117: 1000 hours
Max. temperature	: -4° to 176°F (20° to + 80°C)
Materials	: Housing : Aluminum alloy
	: Shaft : Aluminum hard anodized
	: (Option : Stainless steel)
	: Fasteners : Stainless steel
	: Tagplate : Stainless steel
Application	: Optional on all EL-O-MATIC actuators

### Chemical resistances

Resistance to various inorganic chemicals, organic chemicals, gasolines, oils, detergents, etc. is generally good to excellent, but also depends on temperature and/or concentration. More detailed information available at data sheet A4.204.021

**Hard anodized aluminum**  
(Option : Stainless steel)

**Stainless steel fasteners**

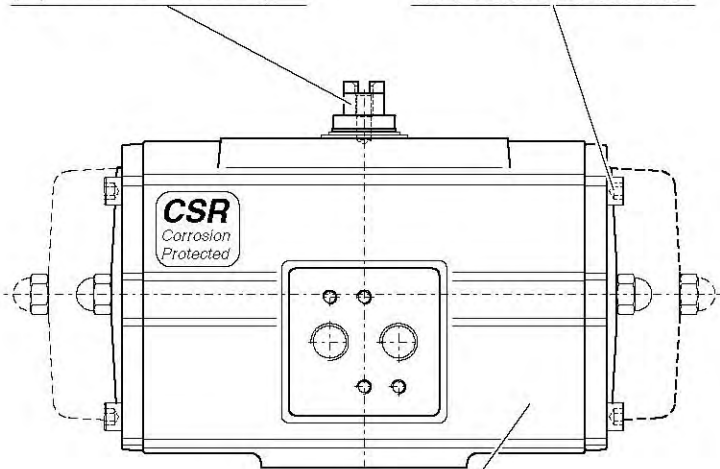

**Coating:**  
20 microns Ceramic filled epoxy resin

**EL-O-MATIC™**

www.El-O-matic.com

Copyright © Emerson Process Management. The information in this document is subject to change without notice.

Updated data sheets can be obtained from our website [www.El-O-Matic.com](http://www.El-O-Matic.com) or from your nearest Valve Automation Center **USA:** +1 813 319 0266 **Europe:** +31 74 256 10 10 **Asia-Pacific:** +65 6501 4600

  
**EMERSON.**  
Process Management

## Data sheet

Sheet No.: A4.204.021 Rev.A  
Date: November 2009

## CHEMICAL RESISTANCE LIST FOR CSR COATING

CSR

### Inorganic chemicals

1	Ammonium hydroxide (10%)	2
1	Calcium chloride (~50%)	3
3	Chlorine	1
3	Chromic acid	1
3	Hydrofluoric acid (50%)	1
1	Caustic potash solution (10%)	3
1	Sodium hypochlorite (saturated)	2
1	Caustic soda solution (10%)	1
1	Caustic soda solution (saturated)	2
1	Phosphoric acid (10%)	1
1	Phosphoric acid (50%)	1

### Organic chemicals

3	Acetone	1
3	Acetonitrile	1
3	Aniline	1
2	Benzene	1
1	n-Butanol	1
3	Butyl acetate	3
3	Chlorobenzene	3
3	Chloroforme	3
3	o-Chlorophenol	3
1	Cyclohexane	1
3	Cyclohexanone	1
3	1,2-Dichloroethane	1
2	Diethyl ether	3
2	Dioxane	1
1	Glacial acetic acid	1
1	Ethanol	2
3	Ethyl acetate	2
1	Ethylene glycol	1
1	Formaldehyde	3
2	Freon 11	2
2	Freon 22	1

1	Excellent
2	Limited resistance; it is recommended to perform field tests under the specified conditions.
3	Not recommended

### Fuels/lubricants

1	Two-star petrol (50°C)
1	Four-star petrol (50°C)
1	Fuel M 15 (50°C)
1	Diesel oil
1	Kerosene
1 to 2	Hypoid bevel gear oil Shell Spirax HD 90 (150°C)
1	Transmission oil Shell Spirax MA 80 (150°C)

### Chemicals

1	Automatic transmission fluid Shell Dextra 11D 20-137 (150°C)
1	Engine oil, mineral, Mihag 1500-40 (150°C)
1	Engine oil, synthetic, Mobil SHC 10 W-40
3	Brake fluid Hydraulan DOT 4
1	Roller bearing grease DIN 51 825

### Technical detergents

2	Genkeene
2	1,1,1- Trichloroethane
2	Triklone A
2	Perchloroethylene

### Miscellaneous fluids

1	Glysantin (BASF)/water
1	Plasticizer DOP
1	Suds
1	Washing-up liquids
1	Household detergents
1	Linseed oil
1	Milk
1	Soapsuds
1	Silicone oils

**Note:** This list has been composed with great care. However, EL-O-MATIC cannot be held responsible, either for any errors in this list or for their consequences. Because of continued testing this list is subject to change without notice.

**EL-O-MATIC™**

www.El-O-matic.com

Copyright © Emerson Process Management. The information in this document is subject to change without notice.

Updated data sheets can be obtained from our website [www.El-O-Matic.com](http://www.El-O-Matic.com) or from your nearest Valve Automation Center **USA:** +1 813 319 0266 **Europe:** +31 74 256 10 10 **Asia-Pacific:** +65 6501 4600

  
**EMERSON.**  
Process Management

# Data sheet

Sheet No.: A1.203.011 Rev. A  
Date: November 2009

## DIMENSION SHEET STANDARD 180° ACTUATOR

180°

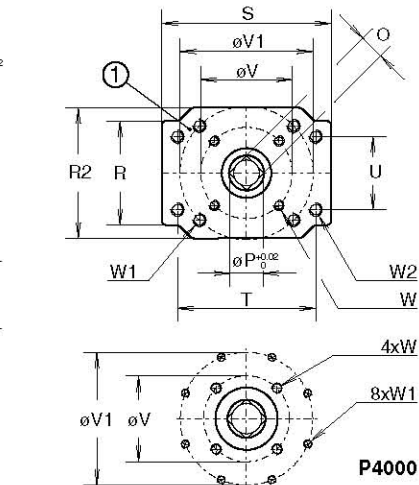
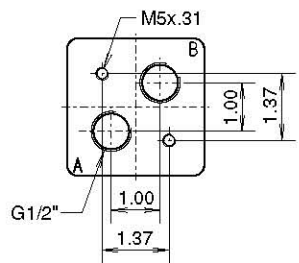
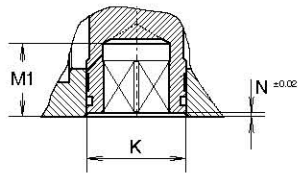
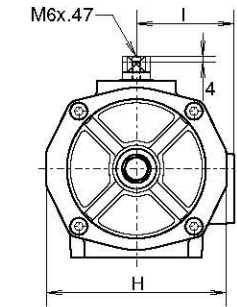
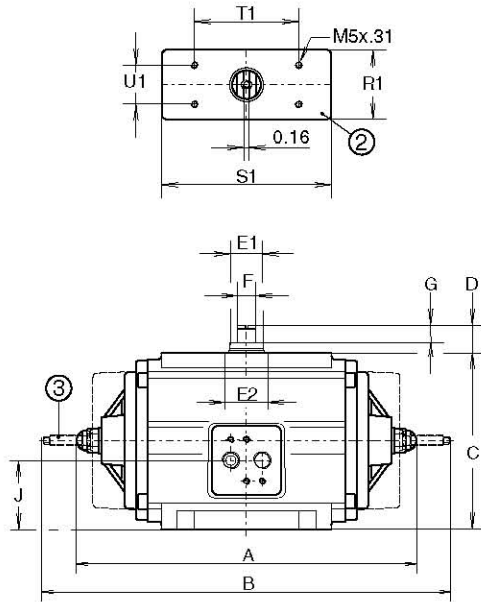
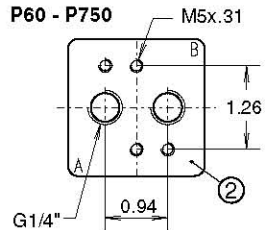

P1100 - P4000

P4000

Dim. in mm.	ACTUATOR TYPE								
	E12	P60	P150	P280	P500	P750	P1100	P2500	P4000
A DA		9.17	11.61	13.94	16.30	17.60	19.76	24.92	29.61
B SR		10.08	13.07	17.09	19.57	21.77	25.24	32.17	42.95
C		3.98	5.31	6.30	7.48	9.21	9.72	14.02	14.96
D		0.79	0.79	0.79	1.18	1.18	1.18	1.18	1.18
E1		0.63	0.87	1.02	1.42	1.42	1.77	2.17	2.52
E2		0.91	1.18	1.38	1.77	1.77	2.17	2.56	3.15
F		0.39	0.55	0.55	0.75	0.75	1.18	1.42	1.42
G		0.47	0.47	0.47	0.75	0.75	0.39	0.39	0.39
H		3.98	5.43	6.61	7.56	9.41	9.84	13.54	14.65
I		2.28	2.95	3.50	4.29	5.28	5.31	7.20	7.87
J		1.69	2.09	2.72	3.74	4.57	4.92	7.01	7.48
K		1.10	1.50	1.89	2.20	2.20	2.95	3.35	4.72
M1		1.06	1.06	1.22	1.50	1.50	2.01	2.60	3.03
N		0.04	0.04	0.06	0.06	0.08	0.10	0.12	0.06
O max.		0.556	0.674	0.871	1.068	1.068	1.424	1.817	2.173
O min.		0.551	0.669	0.866	1.063	1.063	1.417	1.811	2.165
P		0.713	0.992	1.110	1.425	1.425	1.898	2.370	2.843
R		2.36	3.15	3.98	4.37	5.51	5.51	6.69	6.69
R1		2.01	2.36	2.80	3.19	3.94	4.72	6.30	6.30
R2		2.76	3.94	-	-	-	-	-	10.31
S		4.37	5.12	5.55	6.34	8.27	8.27	11.42	11.42
S1		4.37	5.12	5.55	5.55	6.30	8.27	9.65	9.65
T		-	-	-	-	-	-	9.24	-
T1		3.15	3.15	3.15	5.12	5.12	5.12	5.12	5.12
U		-	-	-	-	-	-	3.83	-
U1		1.18	1.18	1.18	1.18	1.18	1.18	1.18	1.18
V		F05	F07	F07	F10	F10	F14	F16	F16
W		1.969	2.756	2.756	4.016	4.016	5.512	6.496	6.496
V1		M6 x .35	M8 x .51	M8 x .51	M10 x .63	M10 x .63	M16 x .79	M20 x1.18	M20 x1.18
W1		F07	F10	F10	F12	F12	-	-	F25
W2		2.756	4.016	4.016	4.921	4.921	-	-	10.000
W1		M8 x .51	M10 x .63	M10 x .63	M12 x .63	M12 x .63	-	-	M16 x 0.98
W2		-	-	-	-	-	-	M16 x 0.98	-

For E12 dimensions see A1.103.102

### Note

1. Flange to ISO 5211, square drive to DIN 3337
2. Top and Solenoid flange to VDI/VDE 3845 (NAMUR).  
P1100 P2500 and P4000 have a non-NAMUR solenoid flange with 1/2" entries.
3. 180° actuators are standard equipped with "L1" limit stops. 120° or 135° rotation is possible with optional LF-option (See data sheet A1.503.01)



www.El-O-matic.com

Copyright © Emerson Process Management. The information in this document is subject to change without notice.

Updated data sheets can be obtained from our website [www.El-O-Matic.com](http://www.El-O-Matic.com) or from your nearest Valve Automation Center **USA:** +1 813 319 0266 **Europe:** +31 74 256 10 10 **Asia-Pacific:** +65 6501 4600



**EMERSON**  
Process Management

# Data sheet

Sheet No.: A1.204.01 Rev. C  
Date: June 2010

## 180° DOUBLE ACTING ACTUATOR TORQUE (In.lb.)

180°

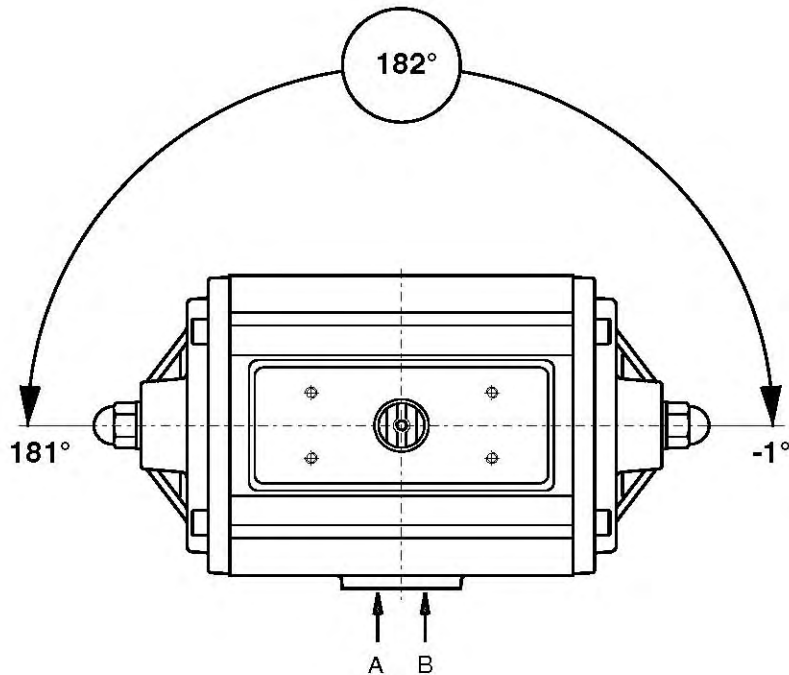
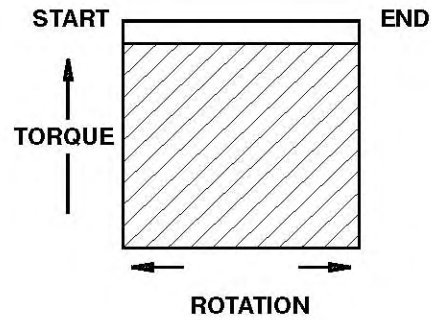

Actuator type	Torque (in in.lb) Supply Pressure (PSI)					
	30	40	50	60	70	80
ED 12	44	59	74	89	104	119
PD 60	104	139	175	210	245	281
PD 150	262	351	441	530	620	709
PD 280	493	662	830	999	1167	1336
PD 500	872	1170	1467	1765	2063	2361
PD 750	1297	1740	2182	2625	3068	3511
PD 1100	1912	2566	3219	3872	4525	5179
PD 2500	4407	5913	7418	8923	10429	11934
PD 4000	7440	9981	12522	15064	17605	20146

### Note

- Emerson Process Management recommends that the valve manufacturer supply the maximum required torque values (Including any adjustments or suggested safety factors for valve service conditions or application).  
Additionally, the valve manufacturer must identify at which position(s) and direction(s) of rotation (Counter Clock Wise or Clock Wise) these maximum requirements occur.
- If in doubt, or you require any assistance with sizing actuators, do not hesitate to contact your nearest Emerson's Valve Automation Division representative.
- Pressure on port "A" opens the actuator\*
- The actuator is shown in closed position\*
- Do not exceed the maximum supply pressure of 6 bar / 87psi.  
(\*code A, data sheet A1.503)

**EL-O-MATIC™**

www.El-O-matic.com

Copyright © Emerson Process Management. The information in this document is subject to change without notice.

Updated data sheets can be obtained from our website [www.El-O-Matic.com](http://www.El-O-Matic.com) or from your nearest Valve Automation Center **USA:** +1 813 319 0266 **Europe:** +31 74 256 10 10 **Asia-Pacific:** +65 6501 4600

**EMERSON**  
Process Management



# Data sheet

Sheet No.: A1.204.02 Rev. C  
Date: June 2010

## 180° SPRING RETURN ACTUATOR TORQUE (In.lb.)

180°

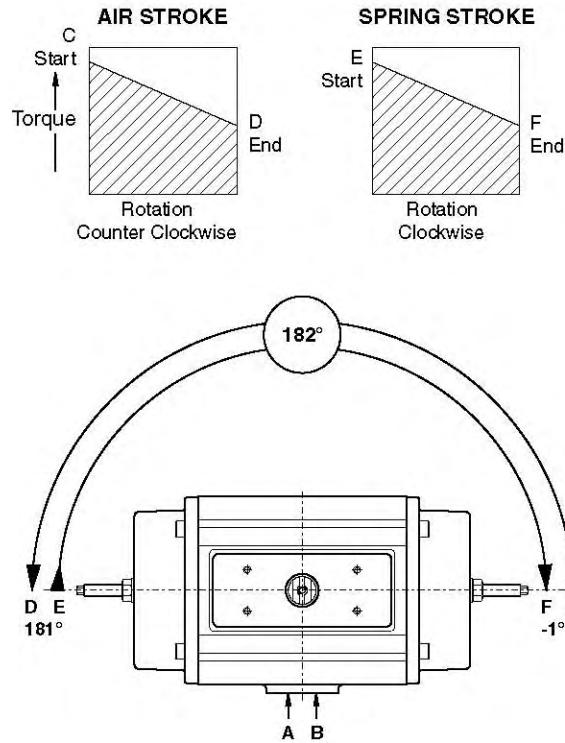

### Note

- Emerson Process Management recommends that the valve manufacturer supply the maximum required torque values (Including any adjustments or suggested safety factors for valve service conditions or application).  
Additionally, the valve manufacturer must identify at which position(s) and direction(s) of rotation (Counter Clock Wise or Clock Wise) these maximum requirements occur.
- If in doubt, or you require any assistance with sizing actuators, do not hesitate to contact your nearest Emerson's Valve Automation Division representative.
- Pressure on port "A" opens the actuator\*
- The actuator is shown in closed position\*
- Do not exceed the maximum supply pressure of 6 bar / 87psi.  
(\*code A, data sheet A1.504)

Actuator type	Spring nr.	Air Stroke (in.lb.)										Spring Stroke (in.lb.)	
		SUPPLY PRESSURE (PSI)											
		40		50		60		70		80		E	F
ES12	2	-	-	33	9	49	25	65	41	81	57	63	41
PE60	8	70	19	105	55	141	90	176	125	212	161	112	62
	10	-	-	88	24	123	60	159	95	194	131	141	78
	12	-	-	-	-	106	30	142	65	177	101	169	93
	14	-	-	-	-	-	-	124	35	160	71	197	109
PE150	8	185	76	274	165	364	255	453	344	543	433	258	150
	10	-	-	233	96	322	186	411	275	501	365	322	187
	12	-	-	-	-	280	117	370	206	459	296	387	225
	14	-	-	-	-	239	48	328	137	418	227	451	262
PE280	8	-	-	493	193	662	361	830	530	999	698	597	303
	10	-	-	-	-	578	202	746	370	915	539	746	379
	12	-	-	-	-	-	-	662	211	830	379	896	455
	14	-	-	-	-	-	-	-	-	746	220	1045	531
PE500	8	-	-	965	256	1263	554	1561	852	1859	1149	1134	452
	10	-	-	-	-	1138	251	1435	549	1733	847	1417	565
	12	-	-	-	-	-	-	-	-	1608	544	1701	678
	14	-	-	-	-	-	-	-	-	-	-	1984	791
PE750	8	-	-	1470	549	1913	992	2356	1434	2799	1877	1529	641
	10	-	-	-	-	1735	583	2178	1026	2621	1469	1912	801
	12	-	-	-	-	-	-	2000	618	2443	1060	2294	961
	14	-	-	-	-	-	-	-	-	2265	652	2676	1121
PE1100	8	1454	430	2108	1083	2761	1736	3414	2389	4067	3043	1999	1000
	10	-	-	1830	549	2483	1202	3136	1855	3790	2509	2499	1250
	12	-	-	-	-	2205	668	2858	1321	3512	1975	2999	1500
	14	-	-	-	-	-	-	2581	787	3234	1441	3499	1750
PE2500	8	2625	890	4124	2389	5622	3888	7121	5386	8620	6885	4675	2934
	10	-	-	3309	1140	4807	2639	6306	4137	7804	5636	5844	3668
	12	-	-	2494	-109	3992	1390	5491	2889	6989	4387	7013	4401
	14	-	-	-	-	3177	141	4676	1640	6174	3138	8182	5135
PE4000	8	4475	1548	7015	4088	9555	6628	12096	9169	14636	11709	7890	4952
	10	-	-	5639	1981	8180	4521	10720	7061	13260	9602	9863	6190
	12	-	-	4264	-127	6804	2414	9344	4954	11885	7494	11835	7429
	14	-	-	-	-	5428	306	7969	2847	10509	5387	13808	8667



www.El-O-matic.com

Copyright © Emerson Process Management. The information in this document is subject to change without notice.

Updated data sheets can be obtained from our website [www.El-O-Matic.com](http://www.El-O-Matic.com) or from your nearest Valve Automation Center **USA:** +1 813 319 0266 **Europe:** +31 74 256 10 10 **Asia-Pacific:** +65 6501 4600



**EMERSON**  
Process Management



**(1) EG-Baumusterprüfbescheinigung**

(2) Geräte und Schutzsysteme zur bestimmungsgemäßen Verwendung in explosionsgefährdeten Bereichen - Richtlinie 94/9/EG

(3) TÜV 00 ATEX 1555

(4) Gerät: 1/3 Stellungsgregler F 20 Typ 328.00.111 bzw. 368.00.071

(5) Hersteller: EL-O-MATIC BV

(6) Anschrift: NL-7590 AE Hengelo

Ex

(7) Die Bauart dieses Gerätes sowie die verschiedenen zulässigen Ausführungen sind in der Anlage zu dieser Baumusterprüfbescheinigung festgelegt.

(8) Der TÜV Hannover/Sachsen-Anhalt e.V., TÜV CERT-Zertifizierungsstelle, bescheinigt als benannte Stelle Nr. 0032 nach Artikel 9 der Richtlinie des Rates der Europäischen Gemeinschaften vom 23. März 1994 (94/9/EG) die Erhaltung der grundlegenden Sicherheits- und Gesundheitsanforderungen für die Konzeption und den Bau von Geräten und Schutzsystemen zur bestimmungsgemäßen Verwendung in explosionsgefährdeten Bereichen gemäß Anhang I der Richtlinie.

Die Ergebnisse der Prüfung sind in dem vorauslichen Prüfbericht Nr. 00 PX 06000 festgelegt.

(9) Die grundlegenden Sicherheits- und Gesundheitsanforderungen wurden erfüllt durch Übereinstimmung mit:

**EN 50 014:1997                      EN 60 020:1994**

(10) Falls das Zeichen "X" hinter der Bescheinigungsnummer steht, wird auf besondere Bedingungen für die sichere Anwendung des Gerätes in der Anlage zu dieser Bescheinigung hingewiesen.

(11) Diese EG-Baumusterprüfbescheinigung bezieht sich nur auf die Konzeption und den Bau des festgelegten Gerätes gemäß Richtlinie 94/9/EG. Weitere Anforderungen dieser Richtlinie gelten für die Herstellung und das Inverkehrbringen dieses Gerätes.

(12) Die Kennzeichnung des Gerätes muss die folgenden Angaben enthalten:

II 2 G EEx ib IIC T8

TÜV Hannover/Sachsen-Anhalt e.V.  
TÜV CERT-Zertifizierungsstelle  
Am TÜV 1  
D-30516 Hannover

Hannover, 25.04.2000



Der Leiter

Diese EG-Baumusterprüfbescheinigung darf nur unverändert weiterverbreitet werden. Änderungen werden nachträglich der Genehmigung des TÜV Hannover/Sachsen-Anhalt e.V. Anzeigepflichtig.

Seite 1/3



EL-O-MATIC  
L. O. M. B. V.  
L. O. M. B. V.  
L. O. M. B. V.  
L. O. M. B. V.

Hengelo, 20.10.2000

Verklaring

volgens



EL-O-MATIC  
L. O. M. B. V.  
L. O. M. B. V.  
L. O. M. B. V.  
L. O. M. B. V.

Hengelo, 20.10.2000

Erklärung

gemäß



EL-O-MATIC  
L. O. M. B. V.  
L. O. M. B. V.  
L. O. M. B. V.  
L. O. M. B. V.

Hengelo, 20.10.2000

Declaration

in accordance with

EMC directives 89/36/EEC

Description: **Elco-Pneumatic Positioner**  
 Applications: **Direct manual Positioning and Operation**

Type: **F20**  
 Certificate: **1023/99/EEC/1/OLE PNEZ and Zertifikat**

Type: **F40**  
 Certificate: **Robson EMC Column det. 31-12-1999**

Serial No.: **Each Elco-Pneumatic Positioner has a serial number consisting of:**  
**EM 0100 12 1999**  
**EM 0100 12 1999**  
**EM 5001 / 1992**  
**EM 5001 / 1999 (and also class B)**  
**EM 5002 / 1999**

Application standards:  
**EN 60073-2:1995**  
**EN 60073-3:1995**  
**EN 60073-4:1995**  
**EN 60073-5:1995**

  
**ELCO Global**  
**Managing Director**

This is a copy of the original certificate. It is not valid if it is not signed by the responsible person.