

# Thermal mass Flowmeter t-mass S

## Direct Mass Flow Measurement of Gases



### Features

- SMART technology permits two-way digital communication via HART protocol
- One standard, compact meter for all gases with a process temperature range of  $-10\dots+100^{\circ}\text{C}$
- Negligible pressure losses
- Single point measurement
- Wide turndown of up to 100:1
- Every sensor is delivered with a calibration certificate traceable to National Standards
- Current and pulse simulation mode for commissioning and diagnosis
- Insertion (AT70), flanged (AT70F) and wafer (AT70W) flowcell formats provide compatibility with any pipeline or ducting installations.
- Can be supplied to suit a wide range of process pipe sizes and connections to suit all areas of industry
- Display and the complete electronic housing can be rotated to enable the best viewing angles

### Flexibility and Convenience

- t-mass measures the mass flow in the process. It can be programmed to display the flow rate in a wide range of engineering units including standardised volume.
- Local, manual configuration is possible with the housing closed, even in hazardous areas

### Safety

- CE mark compliance with electromagnetic compatibility according to EN50081-1:1992 and EN50082-1:1992
- Approved for hazardous area operation
- All meters hydrostatically pressure-tested
- Sensor electronics feature self-diagnostics with alarm functions

Endress + Hauser

The Power of Know How



# Applications

The t-mass thermal flowmeter measures the mass flowrate of a wide range of gas types

Applications include:

- Natural gas flow to boilers and dryers
- Biogas from waste water plant digesters
- Landfill gas monitoring
- Carbon dioxide metering in the brewing and soft drinks industry
- Instrument air in process plants
- HVAC ducts
- Nitrogen, oxygen and argon flows in the steel industry
- Gas production (eg. Ar, N<sub>2</sub>, CO<sub>2</sub>)
- Hydrogen flow in the chemical industry
- Leak detection

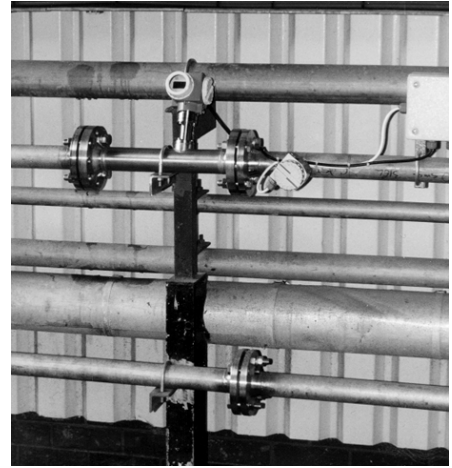

Typical application - Brewery carbon dioxide distribution pipeline

A typical measuring system consists of:

- A t-mass S flow sensor
- A 20..30 V DC power supply rated at 150 mA
- A current or pulse output signal for connection to an external indicator or measuring system (e.g. PLC or SCADA)

## t-mass Measuring System

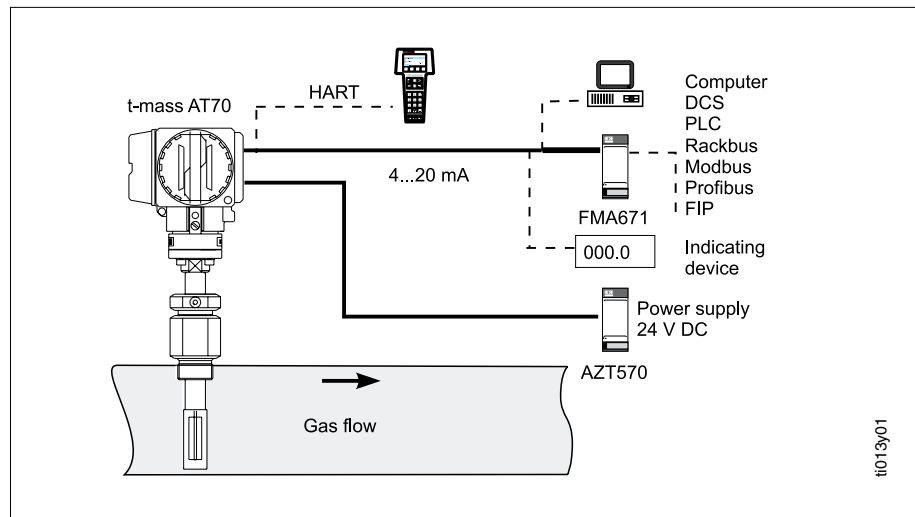

t-mass AT 70 sensor used as an individual measuring point

### t-mass Flow Sensor

The new t-mass S has the following features:

- Microprocessor-controlled
- Self-monitoring and diagnosis of electronics and sensor
- Separate wiring compartment for field connections
- IP 65 protection type
- Built-in electromagnetic interference immunity (EMC)
- Open collector pulse output
- Digital display with bargraph for rate and totalised flow (optional)
- All versions of the sensor are available in compact form with the housing attached directly to the sensor and also in remote form with the housing separated from the sensor by up to 100 metres distance.

### Local Programming

- All functions can be set and all values can be read at the meter using four

pushbuttons, even in hazardous areas, and without opening the housing.

- A HART™ hand-held device can be used to programme t-mass S via the 4...20 mA output, but is not required for normal operation. t-mass S is delivered factory-programmed, but wiring or selection of the individual functions is easily done using a simple menu and the local display, e.g. engineering units, current output functions, open collector function, system parameters.

### Digital Communication

The SMART technology offered by t-mass S permits remote, two-way digital communication

- Using a HART™ handheld communicator or via any computer system utilising a HART™ interface
- Integration to higher level systems can be accomplished using the optional INTENSOR protocol (pending)

# Meter Body Construction

The t-mass family of sensors is available in a wide range of mechanical and housing formats

## AT70 F Flanged Flowcell, (DN 15 ... 150, 1/2" ... 6")

- Integral straight pipework minimises installation requirements and maximises measuring performance
- Welded flange design, with a wide range of optional fittings.
- Optional degreasing for oxygen duty

## AT70 W Wafer, (DN 25...100, 1" ... 4")

- This space-saving version fits between two flanges with all nominal diameters having the same 65 mm (2.5") width.
- A mounting set assures fast and accurate centering in the pipeline (see page 6).
- Optional degreasing for oxygen duty.

## AT70 Insertion, (DN80...1000, 3" ... 39")

- Installed directly onto the pipework via a variety of mounting stub styles. Eg. flanged, screwed thread

### All Versions

- Optional 3.1B material traceability certificate.
- Optional dye-penetrant tested.

### Housing Formats - All Versions

- Compact style with the electronic, display and keyboard attached to the main sensor body.
- Remote version with the electronics, display and keyboard housed separately up to 100m (325 ft) away from the measuring sensor.

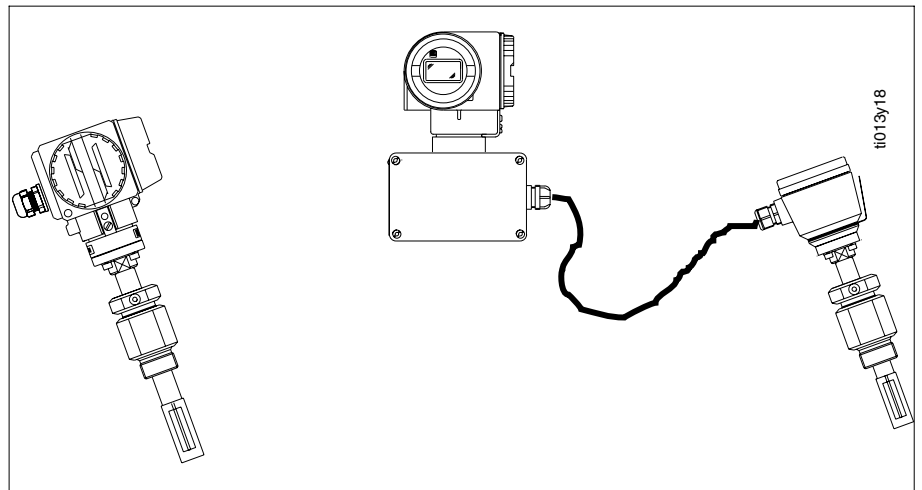

Choice of remote and compact housing formats

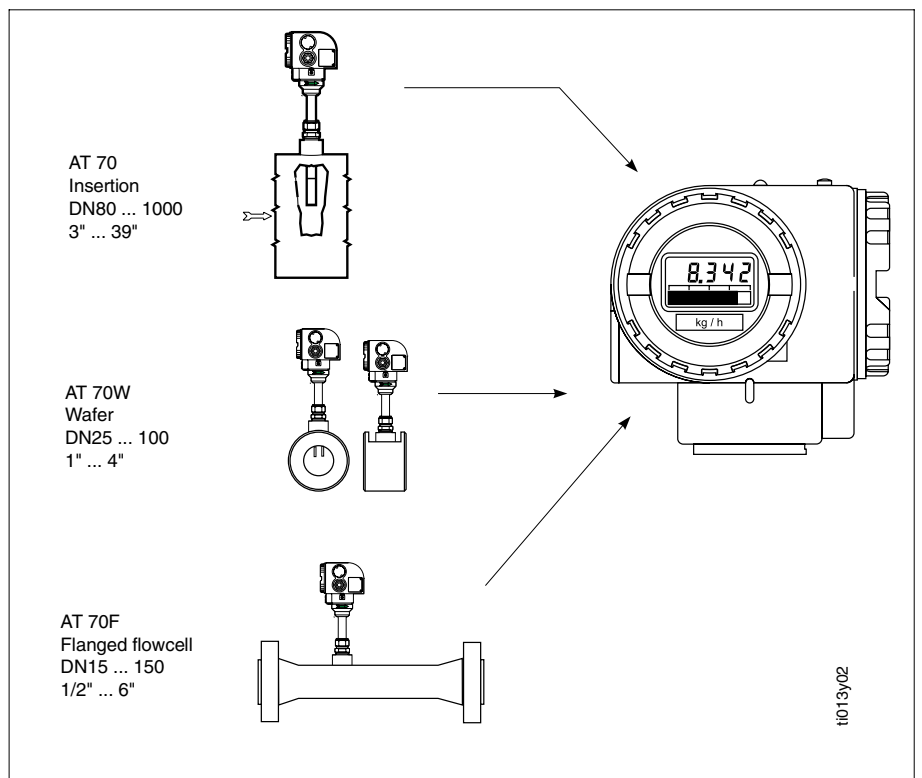

Measuring system t-mass

## Function

### Measuring Principle

Thermal metering is now a well established method of mass flow measurement. It operates by monitoring the cooling effect of a gas stream as it passes over a heated transducer. Gas flowing through the sensing section passes over two PT100 RTD transducers. One PT100 is used conventionally as a temperature sensing device, whilst the other is used as a heater. The temperature transducer monitors the actual gas process temperature, whilst the self-heated transducer is maintained at a constant differential temperature (relative to the measured gas temperature) by varying the current through it. The greater the mass flow passing over the heated transducer, the greater the cooling effect, and current required to keep a constant differential temperature. The measured heater current is therefore a measure of the gas mass flowrate.

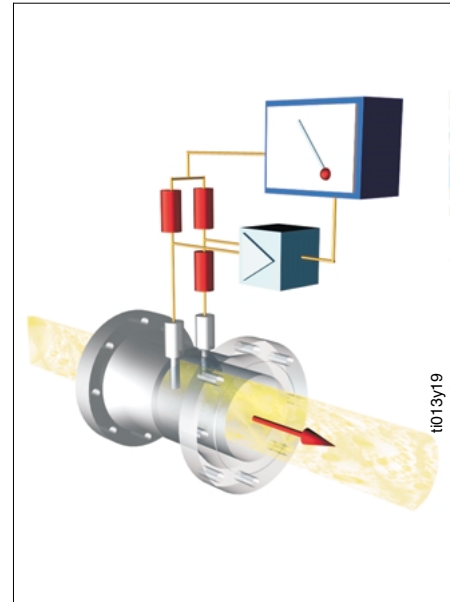

Thermal measuring principle

### The Measuring Sensor

Each AT 70 flow sensor has a four wire connection. Two wires carry the power supply and two wires transmit the measured flow signal back to the control room either as a 4-20 mA current output or as an open collector transistor pulse output. In addition the current output connection supports the HART™ communication facility allowing remote interrogation of the flow, totalised flow and process gas temperature values as well as configuration of the sensor.

### Calibration

Each sensor is subjected to thorough calibration and test procedures and is supplied with an individual calibration certificate traceable to National Standards

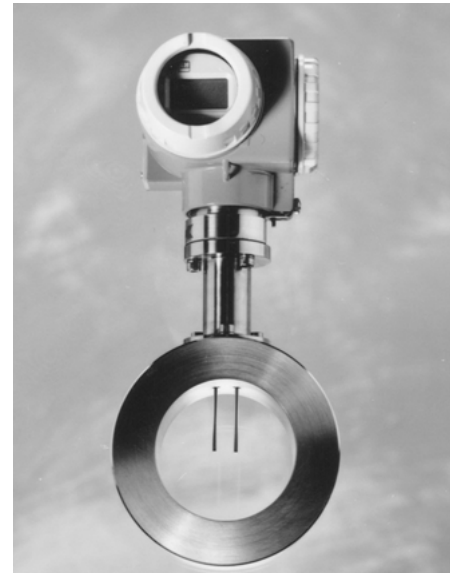

View through the sensor pipe - t-mass AT 70W

The following installation recommendations should be observed as the minimum requirements when installing t-mass in the pipeline.

### Inlet and Outlet Sections

The high sensitivity of the thermal dispersion principle to low flow rates means the flowmeter can also be sensitive to internal disturbances in flowing gas steam (eg. swirl) especially in the smaller pipe diameters ( $\leq$ DN150, 6"). The installed thermal flow sensor should therefore be installed as far as possible **upstream of any flow disturbances**. Disturbance sources can be split into two broad categories:

### Construction and/or Assembly Quality.

Good construction practice should be followed at all times:

- Cleaned pipe and flange welded joints
- Correctly sized gaskets
- Correctly aligned flanges and gaskets
- The use of seamless pipe immediately upstream of the flowmeter
- The use of pipework with a matching internal diameter to that of the flowmeter to ensure that no step disturbance greater than 1 mm (0.05") can occur at the meter inlet or outlet. (3 mm [0.125"] for diameters > DN200 [8"])
- As a general comment anything that disturbs the smoothness of the internal pipe wall within the dimensions stated on page 6 should be eliminated - the goal should be a smooth uninterrupted internal surface.

## Planning and Installation

### Piping requirements

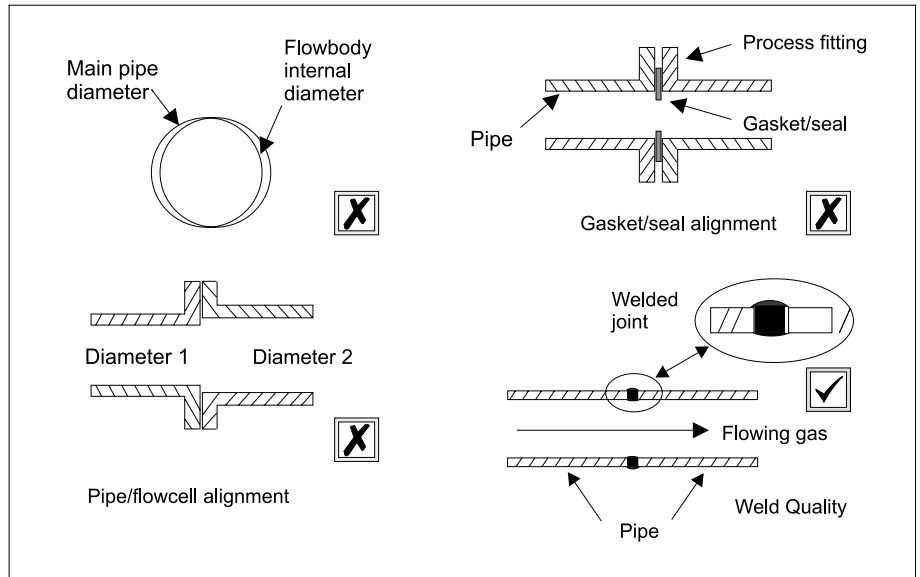

Pipework construction and assembly considerations - conditions to avoid

### Process Components or Pipework Configuration

When disturbances (eg. pipe elbows, reducers, valves, T-pieces etc.) are located upstream of the thermal meter, precautions must be taken to minimise any effects on the measuring performance.

The figures on page 6 illustrate the minimum recommended upstream clear pipe lengths expressed in multiples of the pipe diameter (x DN), longer lengths should always be used if they are available in the metering run.

Regardless of any other consideration the minimum recommendations for clear pipework on either side of the sensor are:

- Inlet sections:
  - minimum 15 x DN for the flanged flowcell (AT70F) version.
  - minimum 20 x DN for the insertion (AT70) or wafer flowcell (AT70W) version.
- Outlet sections:
  - minimum 2 x DN for the flanged flowcell (AT70F) version.
  - minimum 5 x DN for the insertion (AT70) or wafer flowcell (AT70W) version.

### Notes:

- Where two or more disturbances are located upstream of the meter, the longest recommended upstream pipe section is to be observed as an **absolute minimum**.
- It is **always** recommended to install control valves downstream of the flowmeter.
- When an upstream disturbance is present whose disturbing effect cannot be readily evaluated (e.g a dryer, other measuring device such as an orifice plate, turbine meter, vortex meter), it is recommended to consider the disturbance in the same way as a valve (see page 6).
- For very light gases such as helium and hydrogen all recommended upstream straight section values should be multiplied by two.
- Free-standing pipes subject to strong vibration should be firmly attached or supported upstream and downstream of the meter.

### Flow Conditioner

With limited space and large pipes, it is not always possible to have the inlet sections given above. The specially developed AZT532 and AZT534 perforated plate flow conditioners in all but the most severe cases of pipeline disturbances allows the sensor to be installed in the pipework with reduced upstream clear distances. Refer to page 11 for further guidelines.

### Pressure Pulses/measuring Accuracy

Reciprocating pumps and some compressor systems can create strong changes in process pressure in the piping that can induce spurious internal flow patterns and thus cause additional measuring errors. These pressure pulses must be reduced by the appropriate measures. Eg.

- Using expansion tanks
- With inlet expanders
- With a more suitable mounting location

# Planning and Installation

## All versions

### Upstream and Downstream pipe requirements

#### Notes

- For very light gases such as helium and hydrogen all upstream distance recommendations should be doubled.
- The DN150 (6") sized flanged AT70F sensor requires the AZT532 flow conditioner type whereas the DN25 to DN100 (1" to 4") sizes require the AZT534 flow conditioner type.
- The Wafer (AT70W) and Insertion (AT70) versions require the AZT532 flow conditioner types regardless of line size.
- Flow conditioners are not available for all line sizes - check page 11 and with your E+H sales representative before planning your installation layout.

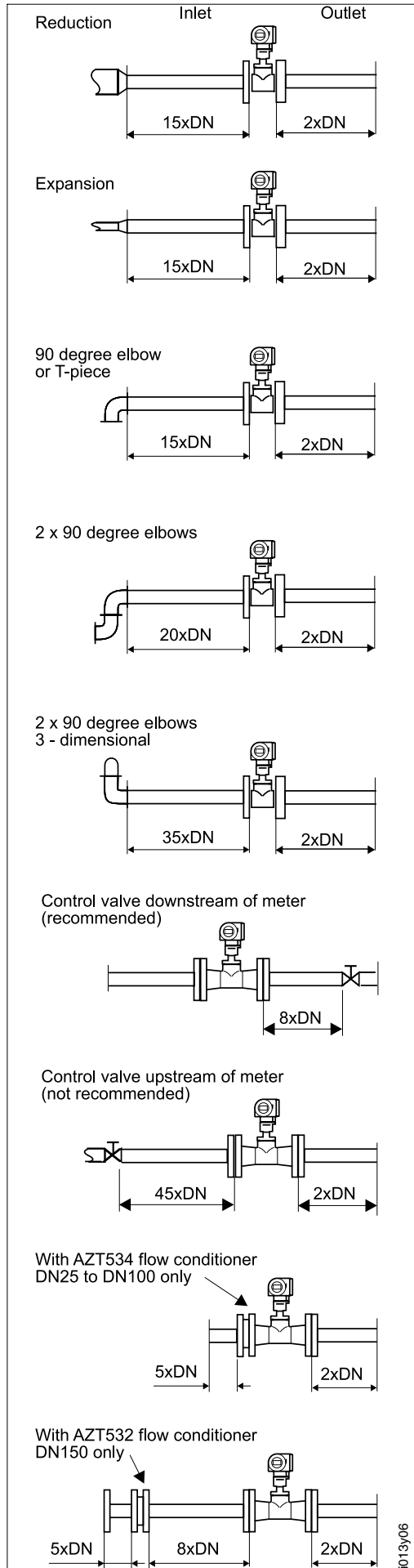

Inlet and outlet piping requirements  
Flanged flowcell version (AT70F)

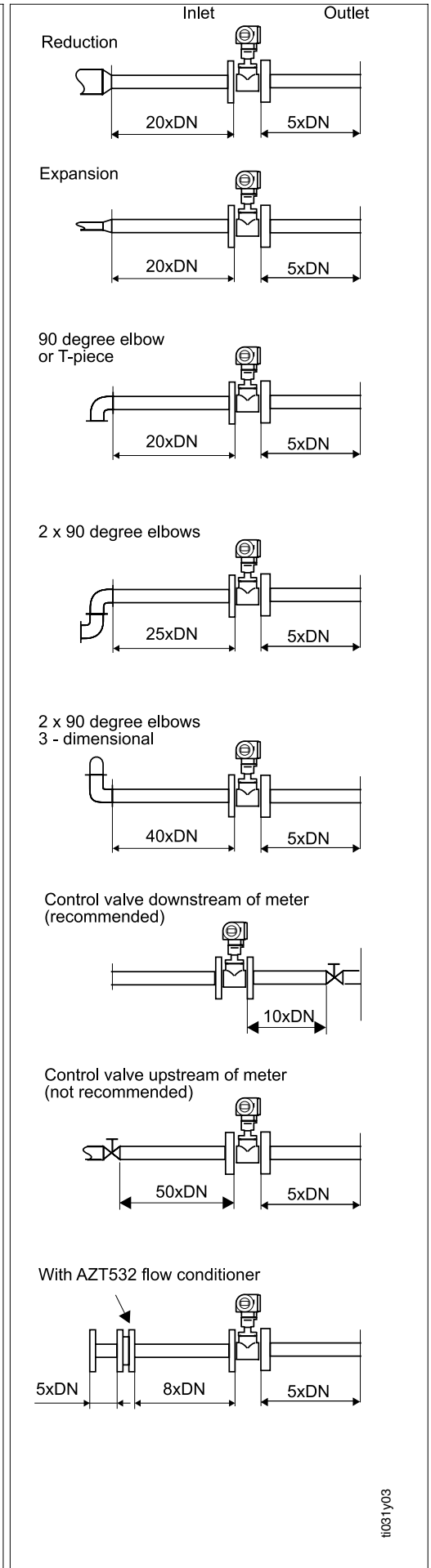

Inlet and outlet piping requirements  
Insertion (AT70) and Wafer (AT70W) versions

## Planning and Installation

### AT70W Wafer version only

Note the following points before mounting the AT70W sensor:

- The flowcell and wafer style meter bodies are protected against damage during transit by two protective disks. Remove both protective disks before installing the flowmeter in the pipeline.
- Take particular care that the internal diameters of any installed gaskets directly upstream and downstream of the meter body are identical or larger than those of the meter body and/or process piping. Gaskets which protrude into the flow will invariably lead to metering inaccuracies.

#### Mounting Set

To ensure the accurate centering of wafer style meters with respect to the flange fitting on any pipework installation, it is essential for maximum performance that the mounting set supplied with the sensor is used.

Each mounting kit comprises

- A set of correctly sized fixing bolts
- Accurately dimensioned centering rings

#### Mounting Procedure

- Place one centering ring over each side of the meter body
- Mount two or more bolts as required with washers on both piping flanges
- Adjust the sensor together with the two centering rings between the bolts already mounted and the piping flanges (including gaskets)
- Mount the rest of the bolts
- Screw tight the bolts in a diagonal tightening pattern

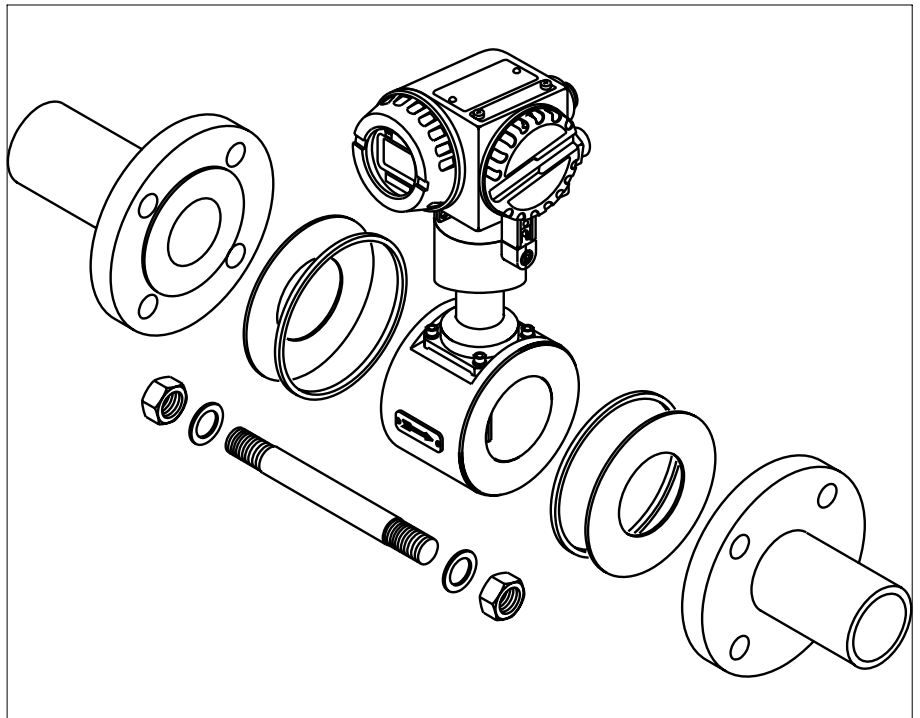

Mounting set for wafer version (AT 70W)

# Sensor mounting details

## AT70 Adjustable Insertion sensor

### Insertion depth

Refer to page 20 for a guideline on specifying the correct sensor length to suit the pipe or duct size, the guidance assumes that a standard AZT70 mounting boss (see page 21) is being used.

### Note.

If any other type or size of mounting boss is used (eg. with an integral ball valve) then the installation must be measured to calculate the correct insertion length which will subsequently allow the correct sensor length to be correctly specified. (Refer to page 9 for further guidelines)

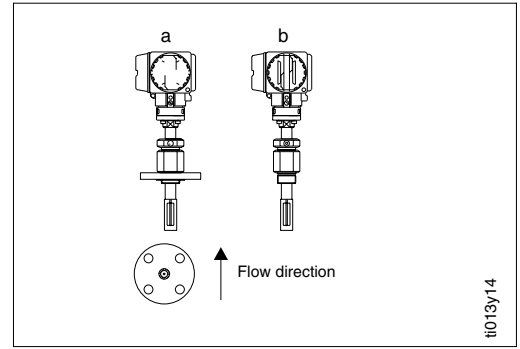

Typical mounting arrangements

- a - Adjustable process length + flange
- b - Adjustable process length + screw fitting

When installing the sensor, the following three dimensions need to be taken into account to allow the correct insertion length to be specified:

- A = Internal diameter of the circular pipe or for a rectangular duct, the duct height if the sensor is to be mounted vertically or duct width if it is to be mounted horizontally
- B = Pipe wall thickness
- C = Depth of the mounting boss on the pipe or duct including the sensor fitting

### For Insertion Sensors Fitted With An Adjustable Insertion Probe Depth (ie. Screwed Process Connection)

The probe section is supplied with a graduated scale along its length calibrated in millimetres. It is important that the sensor be installed so that the top of the adjustable fitting is aligned with the value on the scale that is equal to the following calculated value: (A, B and C are in millimetres - if A, B and C are measured in inches, divide this value by 25.4 before applying them to the formulae below).

- For pipe diameters DN80 (3") and DN100 (4"):**  $B + C + 56$
- For pipe diameters  $\geq$  DN150 (6"):**  $[0.15 \times A] + B + C + 35$

When the probe is at the correct insertion depth the sensor must next be aligned for the correct flow direction detection. (See the next page). After alignment, the probe fitting must be tightened to secure and seal the sensor assembly.

### Note

Insertion sensors mounted in DN80 to DN150 (3" to 6") pipes are calibrated in the factory on the actual line size specified, all insertion sensors for pipe sizes  $>$ DN150 (6") are calibrated on a DN150 (6") or DN300 (12") pipe and numerically scaled to suit the process pipe size (this pipe configuration together with the engineering units selection is field programmable via the integral keyboard and display when fitted).

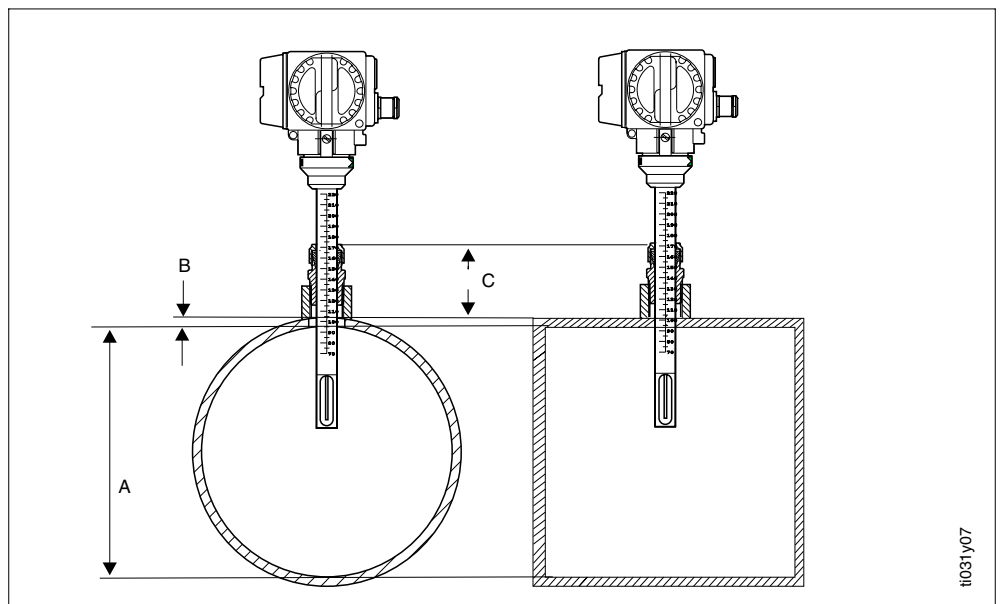

Dimensions required to calculate the sensor insertion depth - AT 70



# AT70 Fixed length Insertion sensor

It is absolutely essential that all installation dimensions are supplied at the time of order to allow correct manufacture and calibration. Installation dimensions to be supplied with order when the mounting stub is supplied by the customer. The same requirement exists for insertion sensors supplied to fit DN80-100 (3-4") pipe sizes (regardless of the type of process connection) since they require calibration with the identical mechanical setup as the final installation to prevent spurious calibration effects caused by the large blockage factor of the sensor relative to the pipe cross-sectional area.

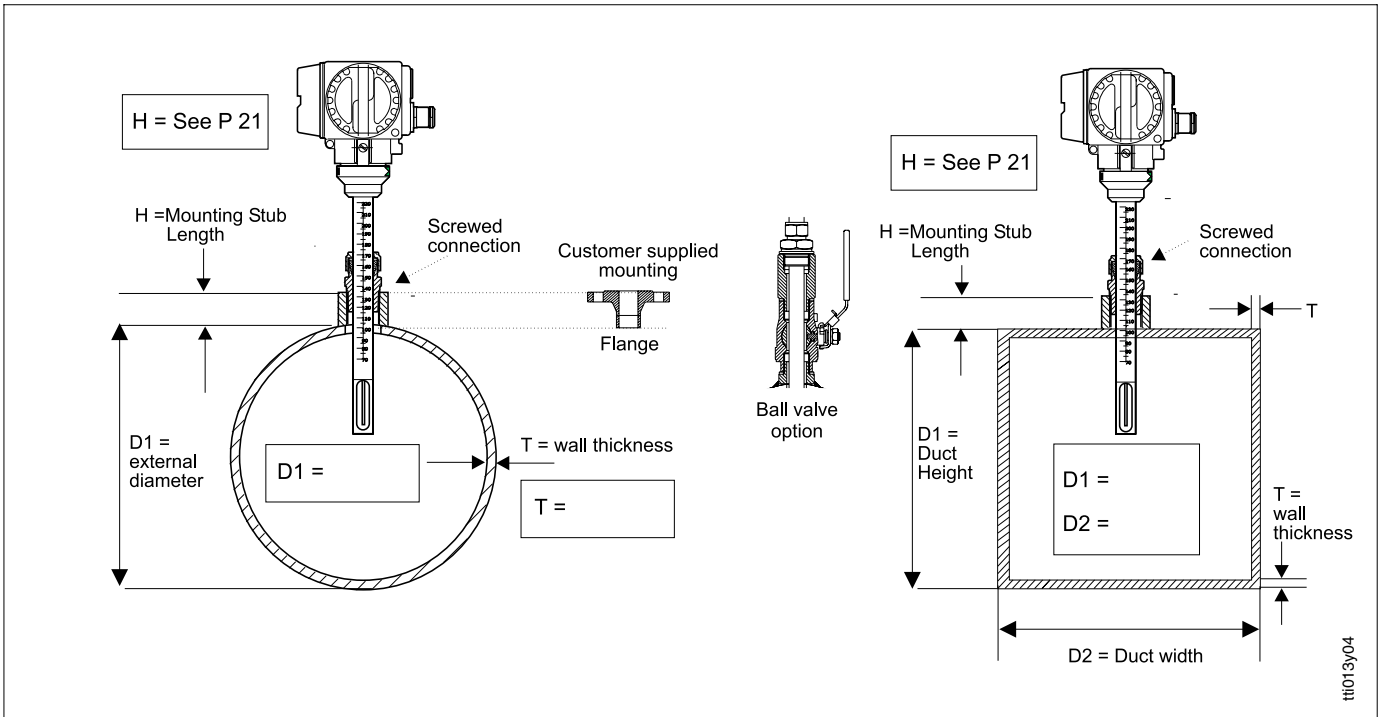

## Insertion sensor Alignment details

### Vertical Alignment

It is important that the sensor mounting boss is welded to the pipe or duct such that the sensor is mounted at 90 degrees to the flow direction. Any deviation from this angle in any plane may cause flow disturbances around the measuring point that could cause errors.

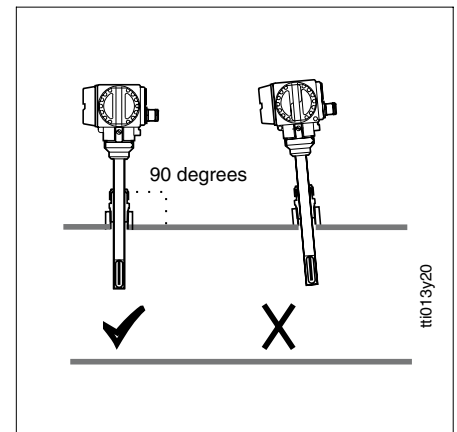

Vertical alignment

### Flow Direction Alignment

It is very important that the sensor is aligned correctly with the direction of flow. There are two guidelines for correct alignment:

- The arrows on the lower sides of the sensor housing assembly are pointing in the same direction as the flow.
- The graduated scale on the insertion probe section should be aligned directly upstream of the flow direction.
- To ensure optimum exposure of the measuring transducers to the flowing gas stream, the sensor must not be rotated more than 7 degrees from this alignment.

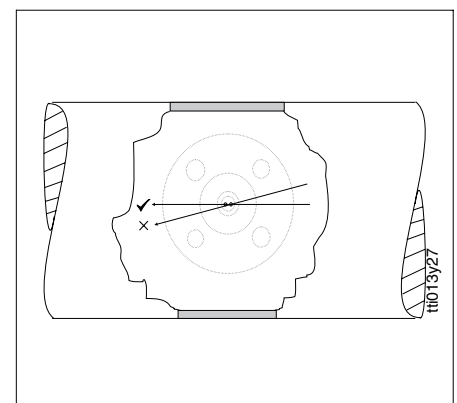

Flow direction alignment

# Planning and Installation

## All models

### Protection IP65 (DIN 40050)

The AT70 sensor family fulfills all the requirements for IP65. After successful installation in the field or after servicing, the following points must always be observed in order to ensure protection to IP65:

- All housing screws and the housing cover must be firmly tightened.
- The cables used for connecting must have the correct outer diameter.
- The cable gland must be firmly tightened.
- The cable should loop down before entering the cable gland to ensure that no moisture can enter it (see figure).
- The protective bushing should not be removed from the cable gland.

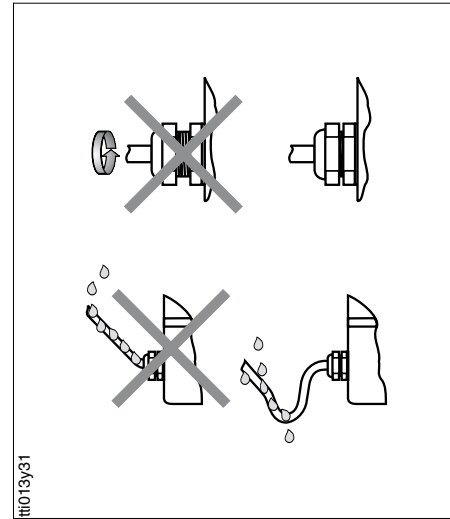

T1013y31

### Sensor orientation

As a general guideline, the AT70W wafer and AT70F sensors can be mounted in any orientation taking care that where free condensation can occur in the line (e.g. biogas) the sensor is orientated to prevent free water collecting on or around the sensing elements.

The AT70 insertion sensor, when being used in a vertical line for leak detection or with very low flows, is recommended to be installed with the flow in the downward direction.

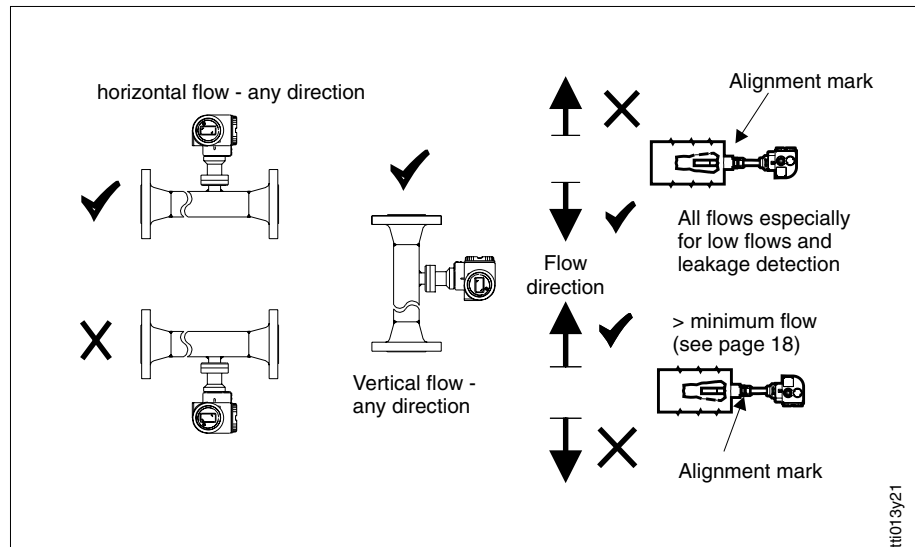

T1013y21

### Pipeline Insulation

When the gas is very humid or saturated with water (eg. Biogas) the pipeline and flowmeter body should be insulated to prevent water droplets condensing on the pipe wall and/or flow transducer. In extreme cases of moisture and temperature variation, it may be advisable to provide trace heating of the pipework and/or flowcell body.

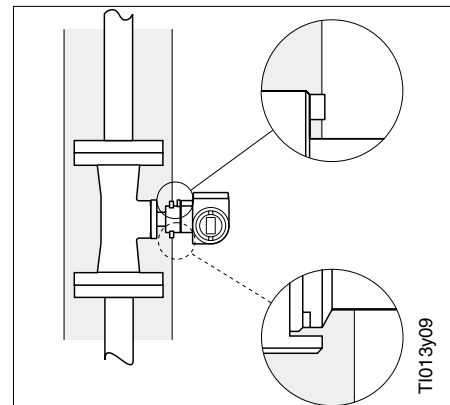

Pipeline insulation

T1013y09

### Ambient Temperatures

It must be remembered that the sensor operating principle is based on a heat loss mechanism, therefore the sensor performs best when the ambient and/or gas temperatures are relatively stable. It is recommended to protect the sensor from the effects of any direct sunlight or extremes of temperature source.

### Flow Direction

It is very important that the sensor body is positioned so that the arrows on the lower sides of the sensor body and/or flow-cell are pointing in the same direction as the flow (see figure).

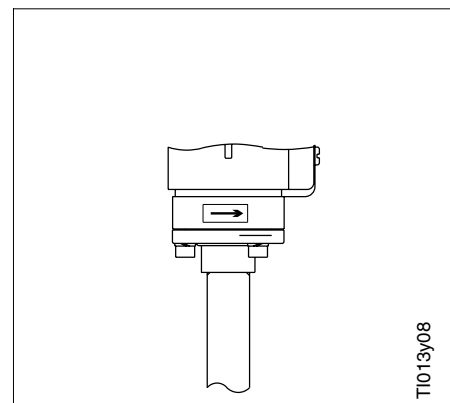

Flow direction alignment

T1013y08

### Local Display - Viewing Angle

The viewing angle of the liquid crystal display can be changed by loosening the restraining screw at the base of the housing and rotating the housing by up to 340°, the restraining screw should be tightened again when the housing is in the required position.

Also within the housing, the display can be rotated in 90° steps (refer to the instructions and figure on page 13 re removal and replacement of the display)

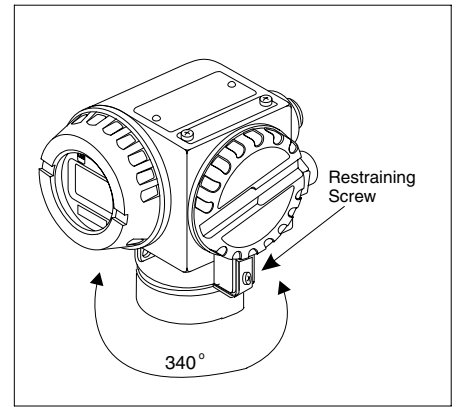

Rotation of the electronic housing

## Flow Conditioning

### AZT532 and AZT534 perforated plate flow conditioners

With limited space and large pipes, it is not always possible to have the clear inlet pipe sections specified previously. The perforated plate flow conditioner in all but the most severe cases of flow disturbance allows the sensor to be installed in the pipework with reduced upstream clear distances. There are two versions depending on the sensor version to be used:

#### AZT532

For use with the insertion (AT70), wafer (AT70W) and the DN150/6" flowcell (AT70F) sensors. This is based on the well known "Mitsubishi" design and for the majority of gas types must be installed 8 diameter lengths upstream of the sensor with a minimum 5 pipe diameter distance required upstream of the actual conditioner itself.

#### AZT534

This is a special version designed specifically for use with all sizes of the flanged flowcell sensors (AT70F) except for the DN150/6" size (see AZT532). The AZT534 conditioner should be fitted immediately upstream of the sensor flowcell with a minimum 5 pipe diameter distance required upstream of the actual conditioner itself.

#### Notes.

- For very light gases such as helium and hydrogen all upstream distance recommendations should be doubled.
- The AZT532/AZT534 conditioners are not available for the DN15 (1/2") and >DN200 (8") pipe diameters.

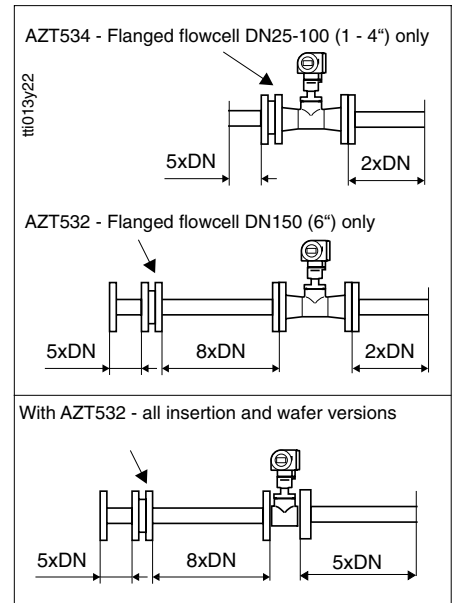

Using the flow conditioner

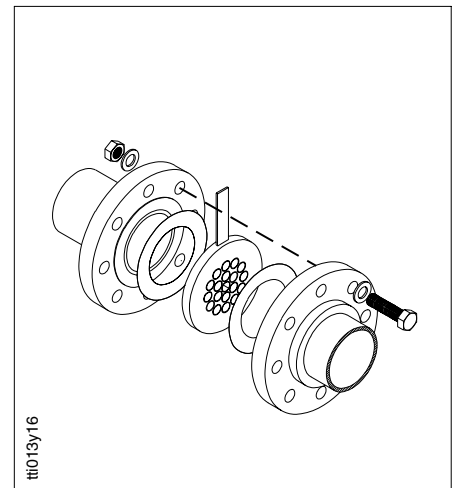

AZT532 and AZT534 flowconditioner mounting arrangement

### Flow Conditioner Pressure Loss Calculation:

$$\Delta p \text{ [mbar]} = A \cdot \rho \text{ [kg/m}^3\text{]} \cdot v^2 \text{ [m/s]} \quad \text{where } A=0.005 \text{ [AZT532]} \text{ or } 0.0085 \text{ [AZT534]}$$

Example for a AZT534 fitted to a DN25/1" sensor with an air flow of 148 kg/hr @ 20°C, 5 bar ( $v = 12 \text{ m/s}$ )

$$\rho \text{ at } 5 \text{ bar and } 20^\circ\text{C} = 7.2 \text{ kg/m}^3;$$

$$\Delta p = 0.0085 \times 7.2 \times 12^2 = 8.8 \text{ mbar}$$

# Electrical Connection

The galvanically isolated output of the sensor can be configured as any one of the following formats:

- Open collector pulse output (0-100 Pulse/sec)
- Passive 4-20 mA current output
- Active 4-20 mA current output

The current output configuration (active/passive) is selected via a switch located on the terminal circuit board in the field wiring compartment.

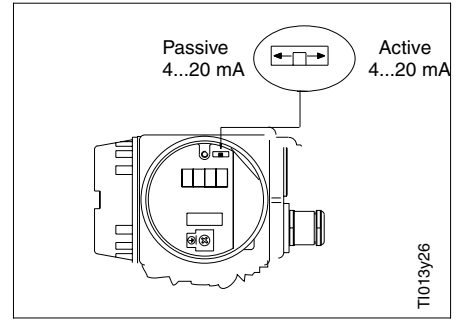

Location of the current output passive/active configuration switch on the terminal connection printed circuit board

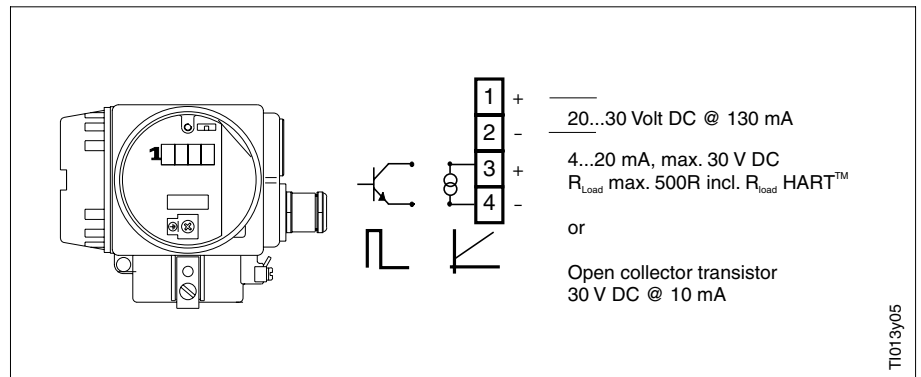

t-mass wiring compartment

TI013y05

## AZT570 rack mounted Sensor field Power supply

AZT570 rack mounting power supply wiring (rear view of terminal connector block) when used with the AT70 sensor

This is the recommended Endress+Hauser power supply for the t-mass S sensor

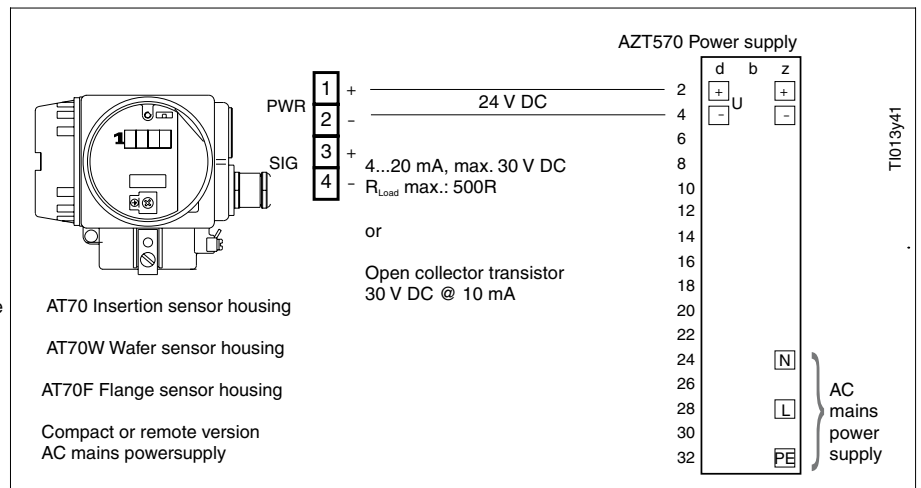

- AT70 Insertion sensor housing
- AT70W Wafer sensor housing
- AT70F Flange sensor housing
- Compact or remote version
- AC mains powersupply

TI013y41

## Active current output

Used where the flow indicator has an passive input (eg. passive indicator, passive D.C.S (Digital Control System) current input). This is the factory default setting.

Contact your local E+H representative for details of suitable indicating devices: E.g. ...

Indicators:  
VU2520, VU2550

Computer interfaces  
FXA191, FMA671

Recording indicators  
Chroma-log, Mega-log, Memo-log, Memograph

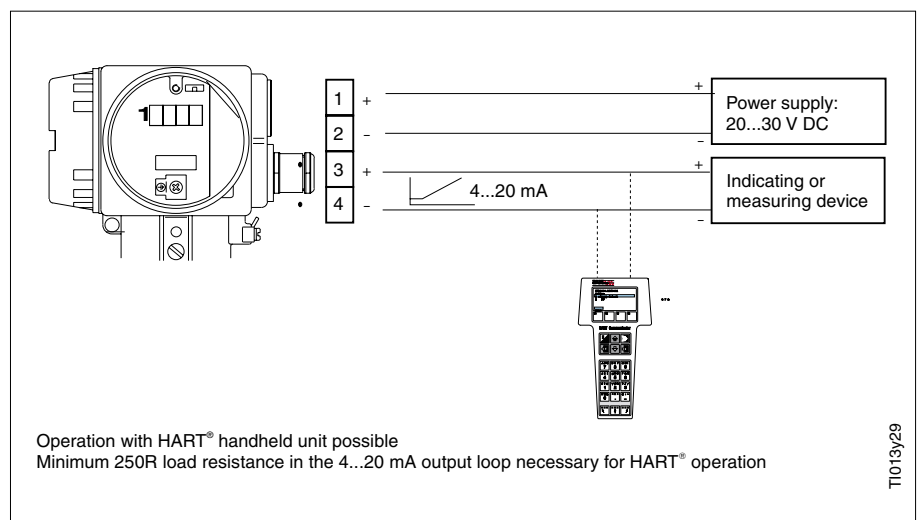

Operation with HART® handheld unit possible  
Minimum 250R load resistance in the 4...20 mA output loop necessary for HART® operation

Active current output wiring

TI013y29

## Passive current output

Used where the flow indicator has an active input (eg. passive indicator with external power supply, active D.C.S current input)

Contact your local E+H representative for details of suitable indicating devices: E.g. ...

Indicators:  
RIA250/251, VU2520, VU2550,  
VU2653, VU2623

Computer interfaces  
FXA191, FMA671

Recording indicators  
Chroma-log, Mega-log, Memo-log,  
Memograph

Passive current output wiring

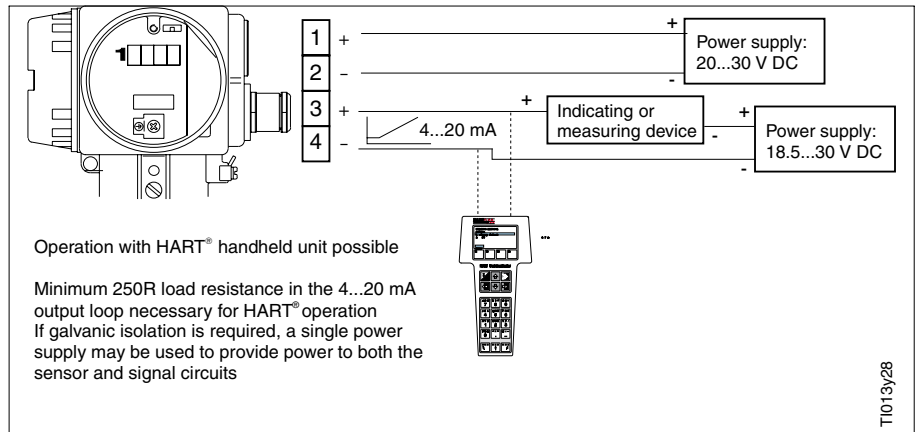

## Open collector transistor pulse output

As an alternative to the current output, the t-mass signal output can be configured as a passive open collector transistor or active voltage pulse output for use with a self or externally powered electronic counter or DCS pulse input. If specified at the time of order, the output will be configured as requested however the output can be re-configured in the field by a combination of switch settings and the programming matrix.

### Note.

The HART™ communication feature of t-mass S cannot be used when the open-collector transistor output is selected.

## Configuration

The output is configured by two internal switches that can be accessed in the main electronics housing

- Remove the display module by unscrewing the cover with the glass window
- Prise the LCD module carefully from the display bezel with a small screwdriver and unplug the display connector from the main circuit board
- Remove the display bezel by unscrewing the two fixing screws
- Set the two switches on the indicated circuit board (see figure) to the "Pulse" position
- Reassemble the display and bezel in the reverse order

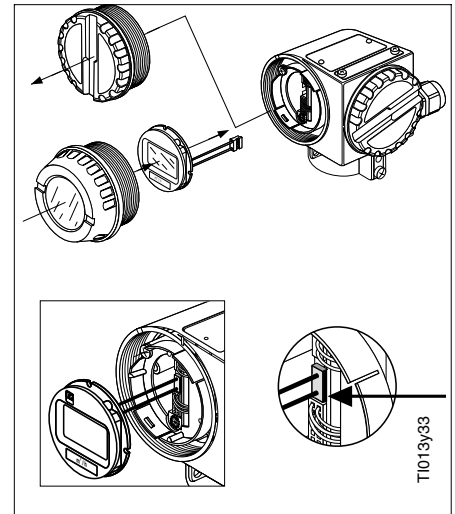

Mounting/ removing the local display module  
Location of the pulse/current output configuration switches in the main electronics compartment after

### Note:

The programming parameters "FS", "OcFu" and "P.SCA" must be reconfigured before the pulse output will function. This can be done during the commissioning of the system (refer to the Operating Manual BA006 for further details).

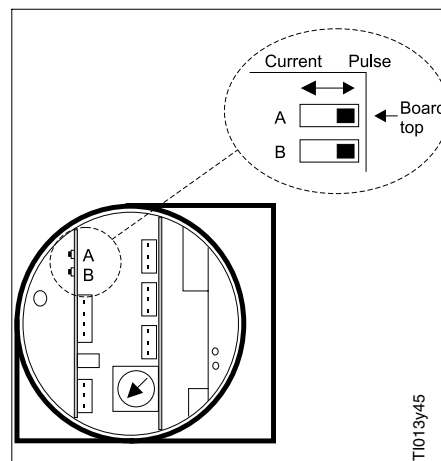

Location of the pulse/current selection switches after the display and display bezel have been removed - Remote Electronics version only

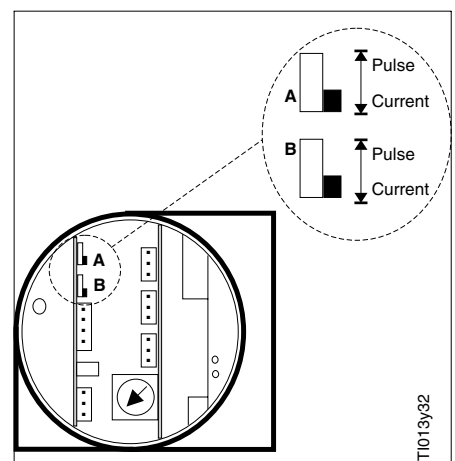

Location of the pulse/current selection switches after the display and display bezel have been removed - Compact sensor version only

### Pulse Output Type

Once the above switches have been set to "Pulse", the active/passive switch on the terminal connector circuit board configures the pulse output as either:

- Active: a voltage output from terminal 3 that switches from an open circuit condition when the pulse is "off" and >12 V when the pulse is "on" (relative to terminal 4) This is the normal setting for most electronic counters
- Passive: an open collector transistor that has an internal 470R resistor in its collector (see figure below). The transistor functions as a resistive "switch"

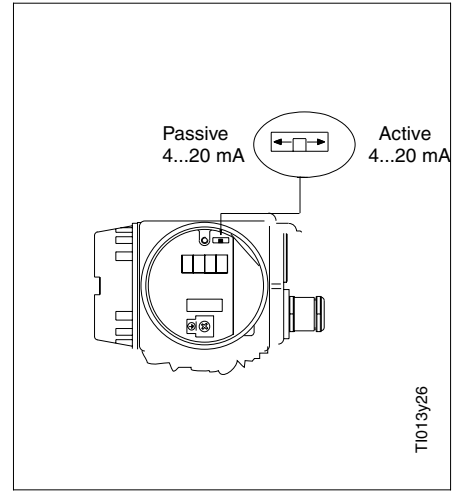

Location of passive/active configuration switch on the terminal connection printed circuit board

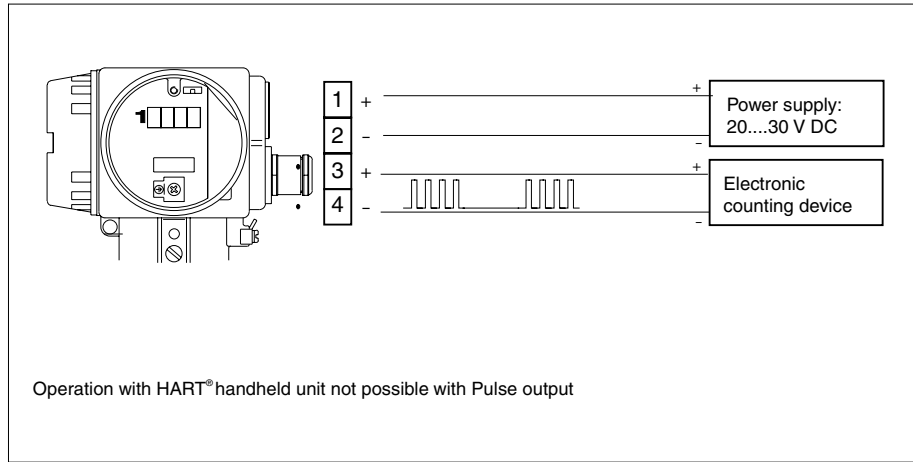

Typical wiring configuration for active pulse output operation with a self-powered electronic counter

For some counting devices the active pulse output may not be suitable due to a variety of reasons e.g incompatible on/off voltage thresholds, very low counter input impedance, high input current demand of the counter. The "passive" pulse output mode allows the open-collector output to be configured in a variety of different ways to suit the counting device.

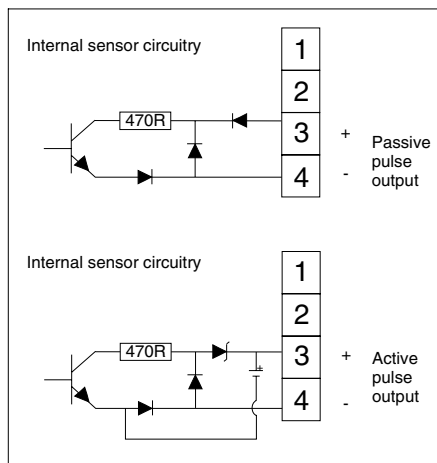

The basic AT70S open-collector output circuit

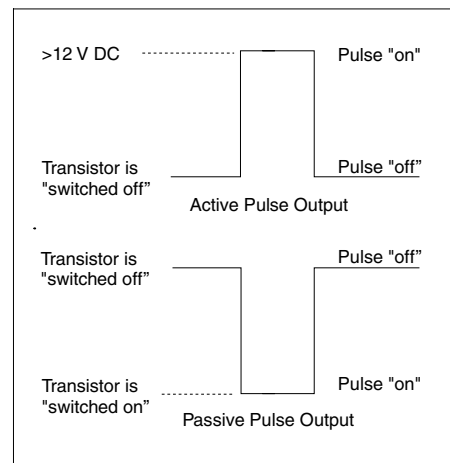

Active and passive pulse output waveforms

## EMC/RFI recommendations

In order to conform to statutory EMC/RFI requirements the electrical installation should accommodate the following points:

- The sensor power supply and signal output should be connected to the measuring/indicating system by either a single screened or shielded 4-core or two twin core screened or shielded cable runs, the screen or shield should be earthed at the sensor end of the cable only. Earth connection points are provided on the outside of the electronic housing and on the inside of the wiring compartment (see figure).
- It is good installation practice not to mix sensor cable runs with other cables carrying high currents and/or voltages. This is particularly important if the HART™ communication feature of the sensor is utilised.
- The sensor should always be operated with all the housing covers fitted.

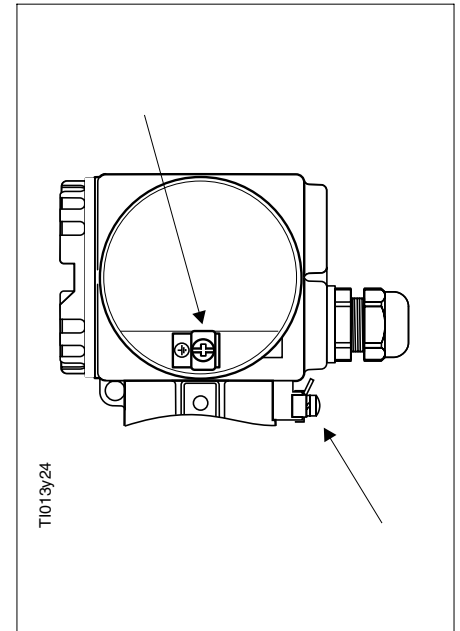

Earth connections inside and outside of the housing.

## Current output loading - HART™

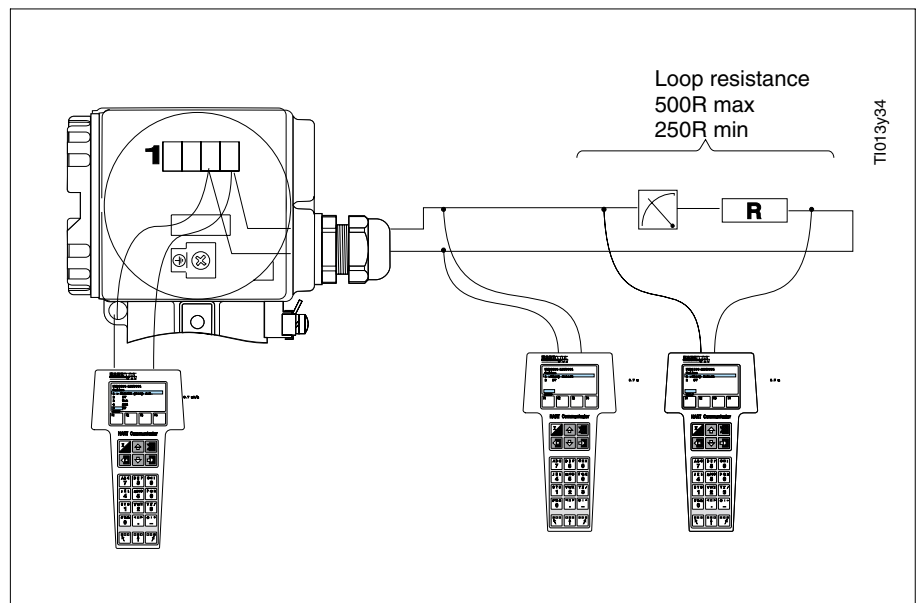

- Where data transfer takes place over the 4...20 mA line via HART™ protocol (→ hand-held device), the minimum load resistance is 250 Ω ( $U_S = \text{min. } 18.5 \text{ V DC}$ ).
- When the HART handheld device is used, the LCD display will 'freeze' at the current value.

# Remote housing configuration and wiring

The AT70 sensor family can be supplied with the main electronics, display and keyboard contained in a remote housing that can be mounted up to 100m (325 ft) away from the sensor.

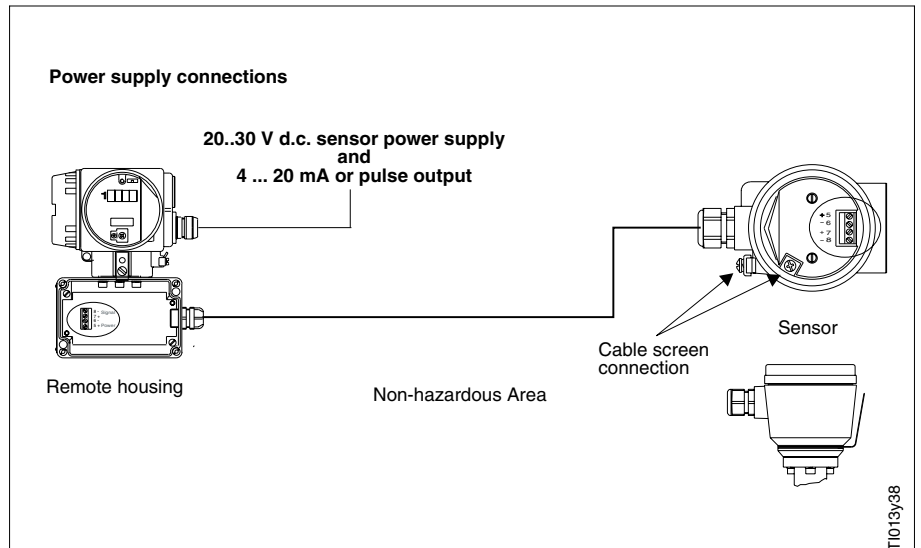
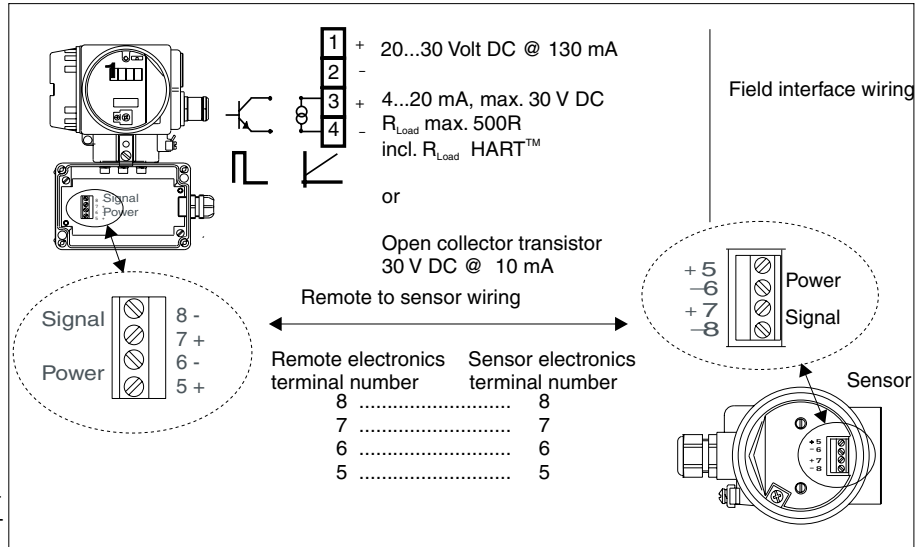
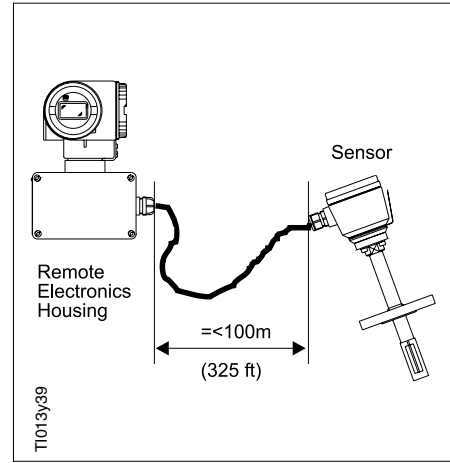

# Hazardous area operation

The remote version can be supplied to 3 certification levels depending on the installation requirements and mix of hazardous area classifications:

## Remote sensor version

- EEx d [ia] ia IIC T4 - remote housing Ex d with the Ex i sensor both in the hazardous area
- [EEx ia] IIC - remote in the safe area with the sensor in the hazardous area
- IEC 79-15 - type n for Zone 2 operation

## Compact sensor version

The compact sensor can be supplied for hazardous area operation as follows:

- IEC 79-15 (Type n) for Zone 2 operation



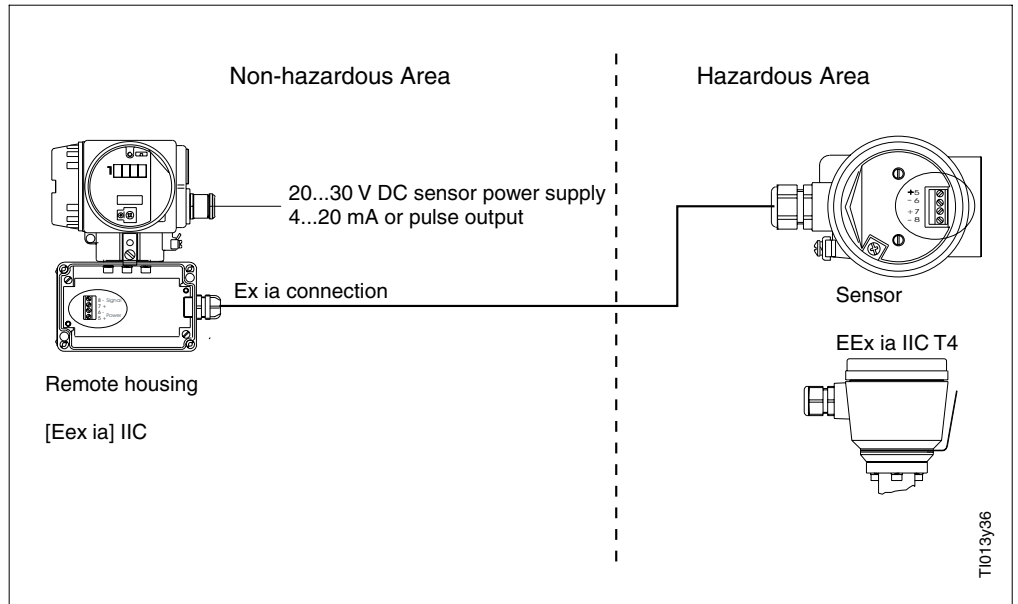

Remote housing to sensor wiring - Remote electronics in the non-hazardous area, sensor in the hazardous area

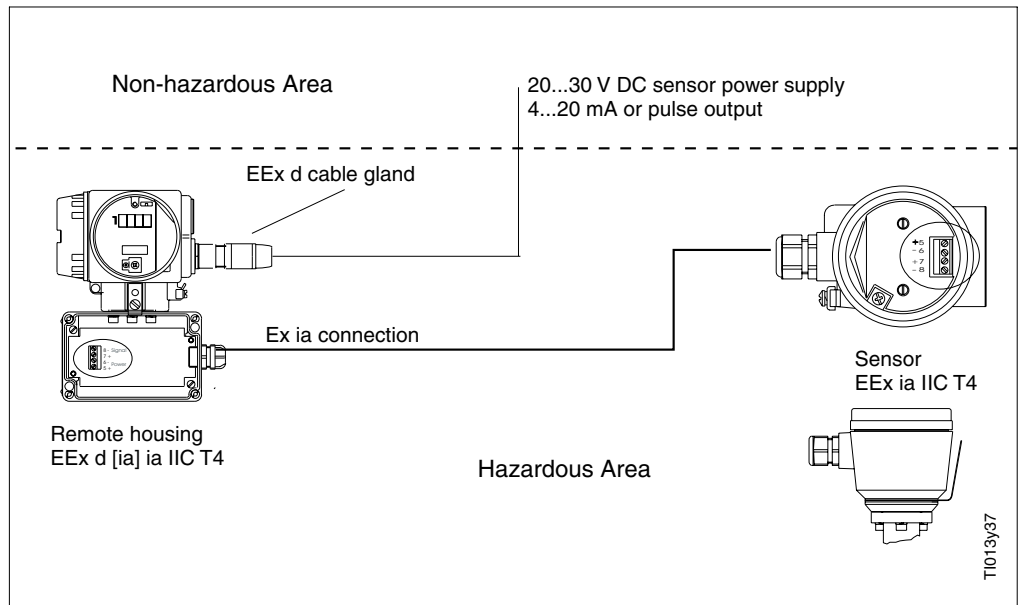

Remote housing to sensor wiring- both the remote electronics and the sensor in the hazardous area

### Remote electronics to sensor cable characteristics - EEx

Sensor circuit	Ex gas group	Maximum cable capacitance (nF)	Maximum cable inductance (mH)	Maximum L/R ratio (mH/R)
POWER connections	IIA	3416	4.98	0.576
	IIB	1281	1.87	0.216
	IIC	427	0.622	0.072
SIGNAL connections	IIA	6320	1760	43.2
	IIB	2370	660	16.2
	IIC	790	220	5.4

### Cable Specification (For the Remote Housing to Sensor wiring only)

Power and Signal circuits

- 4 core, overall screened - 4 x 0.5 mm<sup>2</sup>
- Conductor resistance per core - 40R/Kilometer
- Capacitance - core/screen <=200 pF/metre

### Note

The maximum distance between the sensor and the remote electronics is 100m (325 ft).

# Calibration

A thermal sensor must be individually calibrated to suit the process gas that it is to measure. Each sensor leaving the factory is supplied with 2 calibration documents:

- A calibration certificate pertaining to the reference gas and calibration conditions used for the actual calibration procedure (normally air at ambient temperature and pressure) which is traceable to National Standards.
- A Calibration Statement pertaining to the actual process gas that the sensor has been programmed to measure.

## Notes

- Special calibrations can be carried out in the factory depending on the required gas and process conditions.
- The calibration limits for air and the most commonly used gases for t-mass are set out in the supplementary calibration information sheet SD013/05/e/03/97.
- Consult your local E+H representative for gases not included in this document.
- It is preferred to program the sensor in the factory for the process gas with the actual temperature and pressure conditions used in the final installation and thus this information should be provided at the time of order if possible. If this information is not known or available at the time of order, it can be programmed into the sensor in the field using the HART handheld device. Consult your E+H Service representative for further advice.
- It is possible to change the programmed gas data in the field using the HART handheld device or by using the E+H proprietary PC based software WINSOFT. Consult your E+H Service representative for further advice.

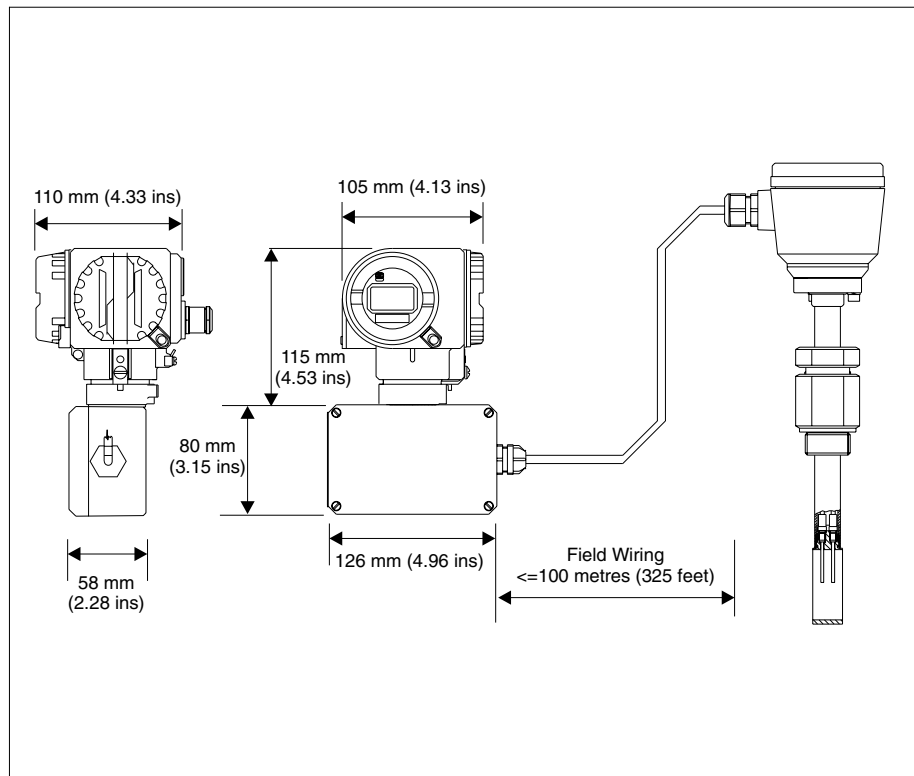

# Dimensions

## AT 70F

### Flanged flowcell version

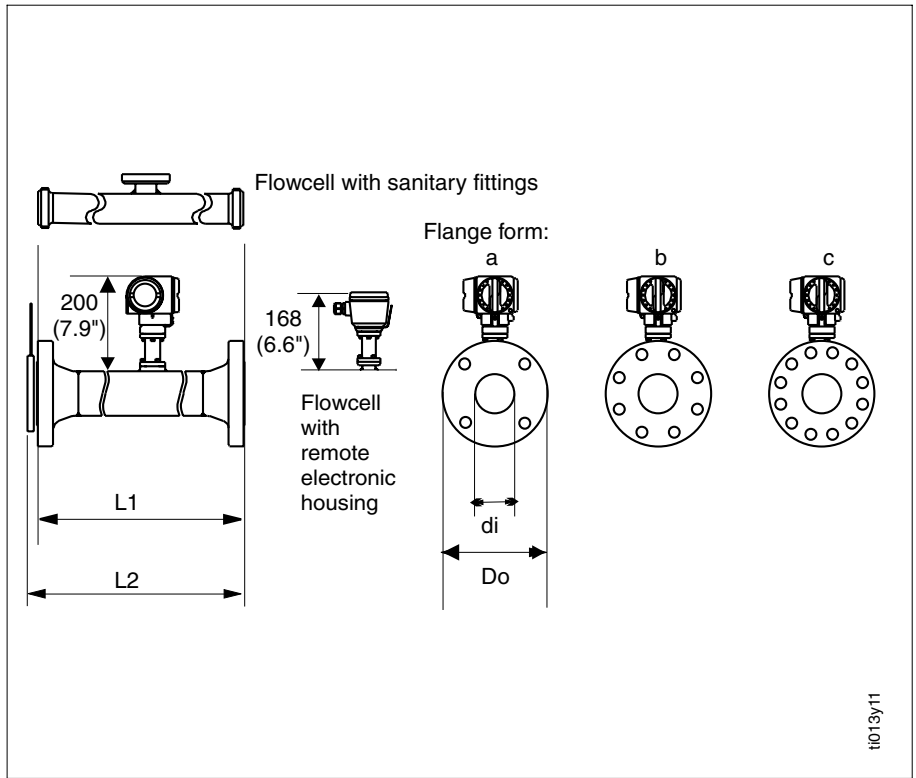

Dimensions

Pipe size	Pressure rating (DIN/ANSI)	L1 mm (inches)	L2 mm (inches)	di mm (inches)	Do mm (inches)	Flange form	Weight kg (lbs)
15 (1/2")	PN40	220		17.08 (0.672)	95	a	3.8
	Cl 150	(8.66)		15.5 (0.622)	88.9	a	(1.73)
25 (1")	PN40	245	249.3	28.5 (1.12)	115 (4.53)	a	5
	Cl 150	(9.65)	(9.81)	26.64 (1.05)	108 (4.25)	a	(2.27)
	Cl 300			26.64 (1.05)	123.8 (4.87)	a	
40 (1.5")	PN40	320	326.5	42.72 (1.68)	150 (5.91)	a	8 (3.64)
	Cl 150	(12.6)	(12.85)	40.9 (1.61)	127 (5)	a	6 (2.73)
	Cl 300			40.9 (1.61)	155.6 (6.13)	a	9 (4.09)
50 (2")	PN40	400	408.4	54.79 (2.16)	165 (6.5)	a	9 (4.09)
	Cl 150	(15.75)	(16.08)	52.51 (2.07)	152.4 (6)	a	8 (3.64)
	Cl 300			52.51 (2.07)	165.1 (6.5)	b	8.5 (3.86)
80 (3")	PN40	640	652.4	82.8 (3.26)	200 (7.87)	b	18.8 (8.55)
	Cl 150	(25.2)	(25.69)	77.92 (3.07)	190.5 (7.5)	a	18 (8.18)
	Cl 300			77.92 (3.07)	209.5 (8.25)	b	21 (9.55)
100 (4")	PN16	800	816.4	108.2 (4.26)	220 (8.66)	b	24 (10.91)
	PN40	(31.5)	(32.14)	108.2 (4.26)	235 (9.25)	b	27 (12.27)
	Cl 150			102.26 (4.03)	228.6 (9)	b	26 (11.82)
	Cl 300			102.26 (4.03)	254 (10)	b	35 (15.91)
150 (6) (see note 4)	PN16	360	384.6	159.3 (6.27)	285 (11.22)	b	27 (12.27)
	PN40	(14.17)	(15.1)	159.3 (6.27)	300 (11.81)	b	33 (15)
	Cl 150			154.06 (6.07)	279.4 (11)	b	27 (12.27)
	Cl 300			154.06 (6.07)	317.5 (12.5)	c	43 (19.55)

Dimensions  
Flanged version

#### Notes.

- 1) Flange connection to ANSI B16.5 (RF) or BS4504 Type B (RF).
- 2) The standard flange style is "slip on".
- 3) Other flange types or coupling arrangements can be supplied to order.
- 4) Requires an additional pipe spool piece between the flowcell and the flow conditioner.

Pipe size	Pressure rating (DIN/ANSI)	L1 mm	di mm	Do mm	Weight (kg)
40 (1 1/2")	DIN11851	320	34.9 (1.37)	50.7 (2)	2.2 (1)
		(12.6)	38 (1.5)	65 (2.56)	2.5 (1.14)
			34.9 (1.37)	50.4 (1.98)	2.2 (1)
50 (2")	DIN11851	400	47.6 (1.87)	64.2 (2.53)	2.6 (1.18)
		(15.75)	50 (1.97)	65 (2.56)	2.6 (1.18)
			47.6 (1.87)	63.9 (2.52)	2.6 (1.18)
80 (3")	DIN11851	640	73 (2.87)	91.2 (3.59)	3.8 (1.73)
		(25.19)	81 (3.19)	110 (4.33)	4.5 (2.05)
			73 (2.87)	90.9 (3.58)	3.8 (1.73)
100 (4")	DIN11851	800	97.6 (3.84)	125.9 (4.96)	6.5 (2.95)
		(31.5)	100 (3.94)	130 (5.12)	6.5 (2.95)
			97.6 (3.84)	118.9 (4.68)	6.5 (2.95)

Dimensions  
Sanitary version

## Dimensions

### AT 70W Wafer version

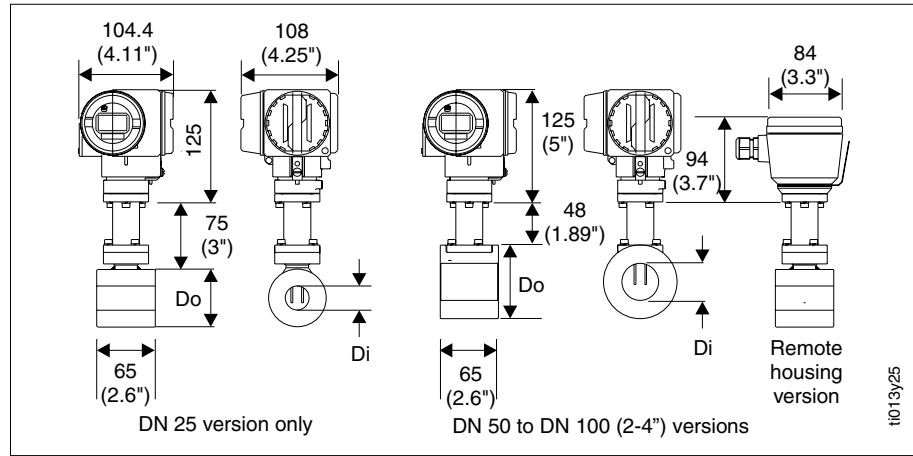

Pipe size	di mm (inches)	Do mm (inches)	Weight - kg (lbs)
DN25 1"	28.5 (1.12) 26.64 (1.05")	63.5 (2.5") 63.5 (2.5")	2.8 (1.27 lbs)
DN40 1 1/2"	43.1 (1.7) 40.9 (1.61")	82 (3.23") 82 (3.23")	3.2 (1.45 lbs)
DN50 2"	54.5 (2.15) 52.5 (2.07")	92 (3.62") 92 (3.62")	3.5 (1.59 lbs)
DN80 3"	82.5 (3.25) 77.9 (3.07")	127 (5") 127 (5")	5.3 (2.41 lbs)
DN100 4"	107.1 (4.22) 102.3 (4.03)	157.2 (6.19") 157.2 (6.19")	6.6 (3 lbs)

## Dimensions

### AT 70 Insertion version

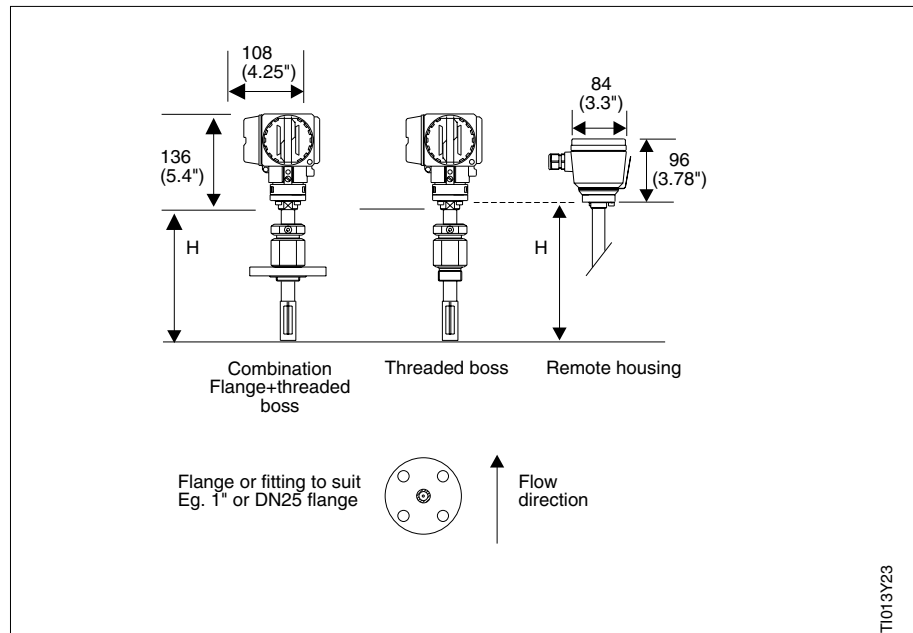

H = total length of insertion of the sensor

Standard lengths are:

235 mm (9.25")  
335 mm (13.2")  
435 mm (17.13")

Other lengths can be supplied to order

Dimensions - Insertion version

Process pipe diameter or duct height	See the next page for details of the AZT70 mounting boss		
	Combination (AZT70 = 60 mm [2.36"])	Threaded boss (AZT70 = 40 mm [1.57"])	Threaded boss with integral ball valve (AZT70 = 153 mm [6"])
3"-8"/DN80-DN200	335	235	335
10-16"/DN250-DN400	335	235	435
18-22"/DN450-DN550	335	335	435
24"-28"/DN600-DN700	335	335	435
30"/DN750	435	335	435
32"-36"/DN800-DN900	435	335	435

For pipe or duct sizes not specified select the nearest size above the actual size.

Table showing the standard insertion length (H) required to suit the pipe size and process connection when mounted with a standard length AZT70 mounting boss (see next page).

#### Important notes for specifying the insertion lengths.

- Any other mounting arrangement or dimension may require a different sized insertion length - if in doubt contact your E+H sales office for advice.

## Accessories

### AZT70 Insertion sensor mounting boss

The AT70 insertion sensor can be mounted to the pipe utilising a wide range of mounting arrangements.

The AZT70 mounting boss is designed to allow an installation point to be easily obtained by welding a fixed assembly directly onto the pipework.

The standard part has a fixed length L:  
 Flanged version L = 60 mm (2.36")  
 Triclamp version L = 40 mm (1.57")  
 Threaded version L = 40 mm (1.57")

The AZT70 can be supplied with other lengths to order including an integral isolating ball valve. When fitted with such a valve L = 153 mm (6").  
 Note - See page 9 for ball valve dimensions.

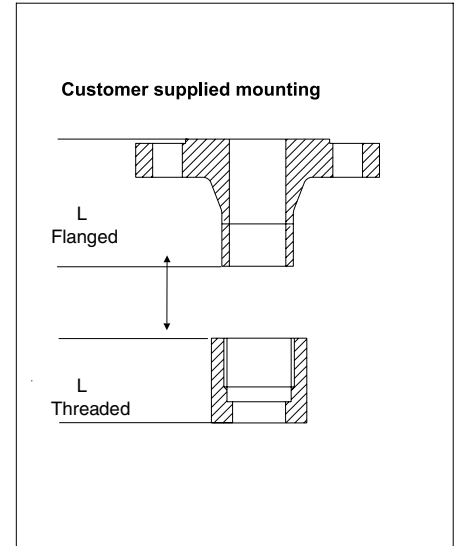

## Flowconditioners

AZT532/ AZT534  
perforated plate  
flow conditioner

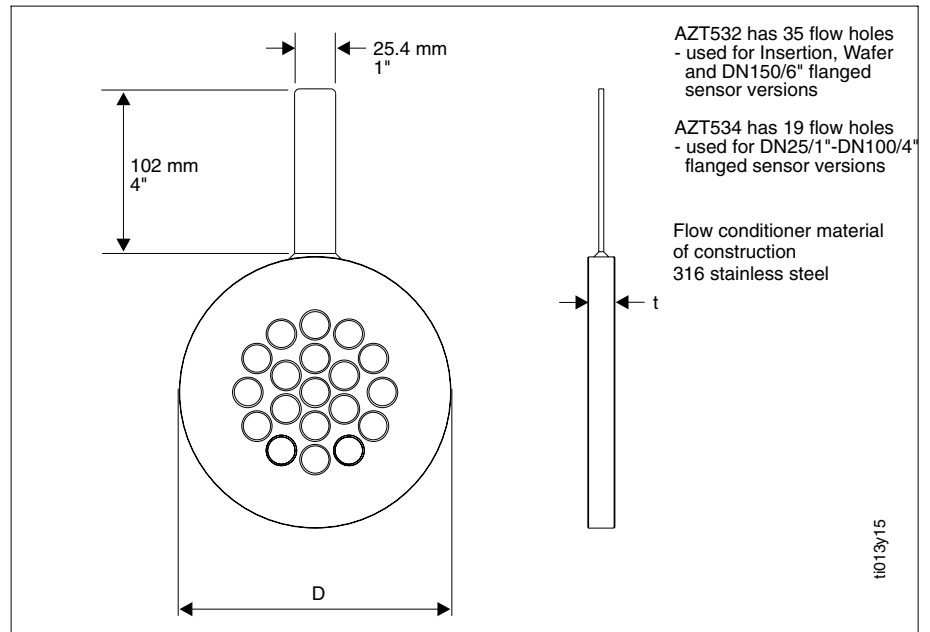

Line Size	Process fitting	D mm (inches)	AZT534      AZT532	
			t mm (inches)	
DN25 1"	PN16/25/40	74 (2.91")	4.6 (0.18")	3.7 (0.15")
	Cl 150	68.5 (2.7")	4.3 (0.17")	3.5 (0.14")
	Cl 300	75 (2.95")	4.3 (0.17")	3.5 (0.14")
DN40 1 1/2"	PN16/25/40	95 (3.74")	6.8 (0.27")	5.6 (0.22")
	Cl 150	88 (3.46")	6.5 (0.26")	5.3 (0.21")
	Cl 300	97.5 (3.84")	6.5 (0.26")	5.3 (0.21")
DN50 2"	PN16/25/40	110 (4.33")	8.8 (0.35")	7.1 (0.28")
	Cl 150	107 (4.21")	8.4 (0.33")	6.8" (0.27")
	Cl 300	113 (4.45")	8.4 (0.33")	6.8 (0.27")
DN80 3"	PN16/25/40	145 (5.71")	13.2 (0.52")	10.8 (0.43")
	Cl 150	138.5 (5.45")	12.5 (0.49")	10.1 (0.4")
	Cl 300	151 (5.94")	12.5 (0.49")	10.1 (0.4")
	PN16	165 (6.5")	17.3 (0.68")	14.1 (0.56")
DN100 4"	PN25/40	171 (6.73")	17.3 (0.68")	14.1 (0.56")
	Cl 150	176.5 (6.95")	16.4 (0.65")	13.3 (0.52")
	Cl 300	183 (7.2")	16.4 (0.65")	13.3 (0.52")
DN150 6"	PN16	221 (8.7")	25.5 (1")	20.7 (0.81")
	PN25/40	227 (8.94")	25.5 (1")	20.7 (0.81")
	Cl 150	224.5 (8.84")	24.6 (0.97")	20 (0.78")
	Cl 300	253 (9.96")	24.6 (0.97")	20 (0.78")

Other sizes can be supplied to order

# Technical Data

**AT 70W: wafer flowcell**  
**AT 70F: flanged flowcell**  
**AT 70: insertion probe**

## Process Limits

Nominal diameters:	70W: DN25 ... 100 DIN 1" ... 4" ANSI
	70F: DN15 ... 150 DIN 1/2" ... 6" ANSI
	70: DN80 ... 1000 DIN 3" ... 39" ANSI
Nominal pressure:	70W/F: PN40 (DIN2501) 70: PN16 (DIN2501) Cl.150 (ANSI B16.5)
Permissible process temperature:	70W/F: -10 ... +100 °C 14 ... +212 °F

## Materials-wetted Parts:

meter body:	SS316 optional Hastelloy (pending)
transducers:	SS316, Hastelloy C276
transducer seals:	viton, optional kalrez, EPDM
Materials - mounting set:	70W only
centering rings:	2 pieces, stainless steel 1.4301
mounting bolts/hex nuts:	1.7258 galvanised
washers:	galvanised steel

## Housing

Housing material	cast aluminum, painted
Protection type	IP 65 (DN 40050)
Ambient temperature	-30...+80 °C (-22...+176 °F)
Display	Liquid crystal display; 4 numeric character with decimal point plus bargraph in % of current output full scale
Cable glands	PG 13.5 standard, others to order

## Electrical

Electromagnetic compatibility (EMC)	IEC 801 part 3: E = 10 V/m (30 MHz...1GHz);
Power supply	20...30 V DC
Power consumption	< 3 W
Galvanic isolation	Between process and outputs: 500 V
Open collector output	I <sub>max</sub> = 10 mA, U <sub>max</sub> = 30 V, P = 300mW Scalable pulse output up to 100 Pulse/sec,
Current output	4...20 mA analogue current output, full-scale value and time constant may be set from the keyboard <b>(minimum T = 1.5 secs @ 63%)</b>
Data storage	Integral non-volatile memory <sup>note 4</sup>
Communication	SMART technology, HART™ protocol via current output

# Technical Data

<b>Hazardous Area Approval</b>	See page 16/17 for system configuration
Remote Display/keyboard housing	Cenelec and SEV EEx d [ia] ia IIC T4 Cenelec and SEV [EEx ia] IIC IEC 79-15 (Type n)
Remote sensor	Cenelec and SEV EEx ia IIC T4 IEC 79-15 (Type n)
Compact sensor version	IEC 79-15 (Type n)

## Accuracy Limits

70F: +/- 2% R on calibrated gas <sup>note 1</sup>  
 70/&W: Expected installed accuracy: +/- [0.5% FS + 2% R] on calibrated gas <sup>note 2</sup>

R = "of measured value"  
 FS = "of fullscale value"

Repeatability (standard deviation)  
 70F: +/- 0.25 %  
 70/70W: +/- 0.25 %

## Process Effects

Temperature coefficient  
 Pipe sizes >DN25 (1") 0.1 %/°C <sup>note 3</sup>  
 Pipe sizes <=DN25 (1") 0.1 %/°C for flows >5 kg/h  
 0.5 %/°C for flows >5 kg/h <sup>note 3</sup>

Pressure coefficient 0.2%/bar <sup>note 3</sup>

### Note 1

This is normally air at ambient conditions with a fully developed flow profile.

### Note 2

Installation dependent.

### Note 3

Referenced to air, dependent on gas type.

### Note 4

The integral totaliser contents are stored in volatile memory and therefore are not retained when the power is removed.

## AZT570

### Sensor field power supply

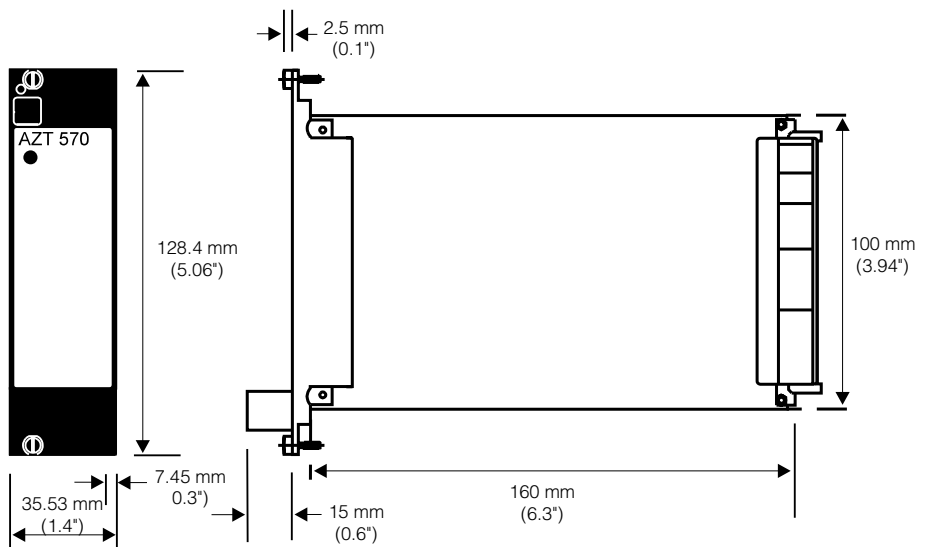

## AZT570

### Sensor field power supply

#### Power supply

90/110/115/120/220/230/240V AC  
±15%, 50/60Hz  
Integrated mains fuse  
90/110/115/120V AC - 125mA slow-blow  
220/230/240V AC - 63mA slow-blow

#### Power output

24 V DC field power to single AT70 sensor

#### Permissible ambient temperature

-10°C...+65°C (do not install in direct sunlight)

#### Storage temperature

-20°C...+85°C

#### Weight:

Approx 0.5kg

#### Mechanical Design

Racksyst plug-in board in accordance with DIN41494, part 5, d=160 mm (6.3"), h=100 mm (4") (Eurocard standard).

#### Male electrical connector

Multi-pin, compatible in accordance with DIN41612 part 3, type F (32 pin).

#### Width

7 pitch units (35mm [1.28"]).

#### Protection

Front panel to IP20

#### Conformity

CE mark compliance with electromagnetic compatibility according to EN50081-1:1992 and EN50082-1:1992

## Supplementary Documentation

- System Information t-mass S (SI 0150/06/e/Mar97)
- AT70 installation and operating instructions (BA 006/05/e/02/98)
- Meter flow ranges (SD013/05/e/03/97))

### Subject to modification

#### Australia

ALSTOM Australia Ltd  
Measurement & Control  
44-46 Mandarin Street  
Villawood N.S.W 2163  
Australia  
Tel: 2 97 22 4777  
Fax: 2 97 22 4883

#### Belgium/Luxembourg

Endress+Hauser S.A/N.V  
Rue Carli Straat 13  
1140 Bruxelles/Brussels  
Tel: 22 48 0600  
Fax: 22 48 0553

#### Canada

Endress+Hauser Ltd.  
1440 Grahams Lane  
Unit No 1, Burlington, Ontario  
Tel: (905) 681 9292  
Fax: (905) 681 9444

Endress+Hauser Ltée  
6800 Côte de Lièsse No 301  
Ville St Laurent, Quebec, H4T 2A7  
Tel: (514) 733 0254  
Fax: (514) 733 2924

#### Denmark

Endress+Hauser ApS  
Poppelgårdvej 10-12  
2860 Soborg  
Tel: 70 131132  
Fax: 70 132133

#### Eire

Flomeaco Co. Ltd  
Industrial Instrumentation Centre  
Clane Business Park  
Clane  
County Kildare  
Tel: 045 868615  
Fax: 045 868182

#### Finland

Endress+Hauser Oy  
Mikkellänkalio 3  
FIN-02770 Espoo  
Tel: 98 859 6155  
Fax: 98 859 6055

#### Great Britain

UK Head Office & Production Centre  
Endress + Hauser Ltd  
Floats Road  
Manchester  
M23 9NF  
Tel: 0161 286 5000  
Fax: 0161 998 1841

Glasgow  
Tel: 0141 248 6234

#### Netherlands

Endress+Hauser B.V  
Postbus 5102  
1410 AC Naarden  
Tel: 03569 58611  
Fax: 03569 58825

#### New Zealand

EMC Industrial Group Ltd  
PO Box 101 444  
North Shore Mail Centre  
56 Tardale Grove  
Albany  
Auckland  
Tel: 9 415 5110  
Fax: 9 415 5115

#### Norway

Endress+Hauser A/S  
Postboks 62  
3402 Lierskogen  
Tel: 03285 9850  
Fax: 03285 9851

#### Singapore

Endress+Hauser (S.E.A) Pte. Ltd  
1 International Business Park  
# 01-11/12 The Synergy  
Singapore 609917  
Tel: 065 566 8222  
Fax: 065 566 6848

#### Switzerland

Endress+Hauser AG  
Stemenhofstrasse 21  
4153 Reinach/BL1  
Tel: 061 715 75 75  
Fax: 061 711 16 50

#### South Africa

Endress + Hauser Pty. Ltd  
5 Commerce Crescent West  
Eastgate Ext. 13  
P.O. Box 783 996  
Sandton 2146  
Tel: 011 444 1386  
Fax: 011 444 1977

#### Thailand

Endress+Hauser (Thailand) Ltd  
89/15 Moo 9  
Vipavadi-Rangsit Road  
Talar-Bangkok, Donmuang  
Bangkok 10210  
Tel: 66 2 996 7811-20  
Fax: 66 2 996 7810

#### Sweden

Endress+Hauser AB  
Bergkallavagen 24 A  
Box 7006  
19207 Sollentuna  
Tel: 08 626 1600  
Fax: 08 626 9477

#### USA

Endress+Hauser Inc  
2350 Endress Place  
PO Box 246, Greenwood  
Indiana, 46143  
Tel: (317) 535 7138  
Fax: (317) 535 8498