

Technical Information

CNGmass

Coriolis flowmeter



The refueling application flowmeter with easy system integration

Application

- Measuring principle operates independently of physical fluid properties such as viscosity or density
- Accurate measurement of compressed natural gas (CNG) in high pressure refueling applications

Device properties

- Flow rates up to 150 kg/min (330 lb/min)
- Process pressure up to 350 bar (5080 psi)
- Rupture disc available
- Robust, ultra-compact transmitter housing
- Pulse output and Modbus RS485
- Transmitter for custody transfer

Your benefits

- Excellent operational safety – reliable under extreme process conditions
- Fewer process measuring points – multivariable measurement (flow, density, temperature)
- Space-saving installation – no in/outlet run needs
- Easy operation – reduced to application needs
- Fast commissioning – pre-configured devices
- Automatic recovery of data for servicing

Table of contents

Function and system design	3	Material	12
Measuring principle	3	Process connections	12
Measuring system	4		
Input	4	Operability	12
Measured variable	4	Local display	12
Measuring range	4	Remote operation	12
Operable flow range	4		
Output	4	Certificates and approvals	12
Output signal	4	CE mark	12
Signal on alarm	5	C-Tick symbol	12
Load	5	Ex approval	12
Galvanic isolation	5	Approval for custody transfer	12
		Modbus certification	12
		Pressure measuring device approval	13
		Other standards and guidelines	13
Power supply	5		
Terminal assignment	5	Ordering Information	13
Supply voltage	5		
Power consumption	5	Accessories	13
Power supply failure	5	Device-specific accessories	13
Electrical connection	6	Service-specific accessories	14
Potential equalization	6	System components	14
Cable entries	6		
Cable specifications	6	Documentation	15
Performance characteristics	7	Registered trademarks	15
Reference operating conditions	7		
Maximum measured error	7		
Repeatability	7		
Influence of medium temperature	7		
Influence of medium pressure	7		
Installation	8		
Installation instructions	8		
Inlet and outlet runs	8		
Special installation instructions	8		
Environment	9		
Ambient temperature range	9		
Storage temperature	9		
Degree of protection	9		
Shock resistance	9		
Vibration resistance	9		
Electromagnetic compatibility (EMC)	9		
Process	10		
Medium temperature range	10		
Fluid pressure range (nominal pressure)	10		
Pressure-temperature ratings	10		
Rupture disk	10		
Pressure loss	10		
Limiting flow	10		
Mechanical construction	11		
Design/dimensions	11		
Weight	11		

Function and system design

Measuring principle

The measuring principle is based on the controlled generation of Coriolis forces. These forces are always present when both translational and rotational movements are superimposed.

$$F_C = 2 \cdot \Delta m (v \cdot \omega)$$

F_C = Coriolis force

Δm = moving mass

ω = rotational velocity

v = radial velocity in rotating or oscillating system

The amplitude of the Coriolis force depends on the moving mass Δm , its velocity v in the system, and thus on the mass flow. Instead of a constant angular velocity ω , oscillation occurs.

In the sensor, two parallel measuring tubes containing flowing fluid oscillate in antiphase, acting like a tuning fork. The Coriolis forces produced at the measuring tubes cause a phase shift in the tube oscillations (see illustration):

- At zero flow, in other words when the fluid is at a standstill, the two tubes oscillate in phase (1).
- Mass flow causes deceleration of the tube oscillation at the inlet (2) and acceleration at the outlet (3).

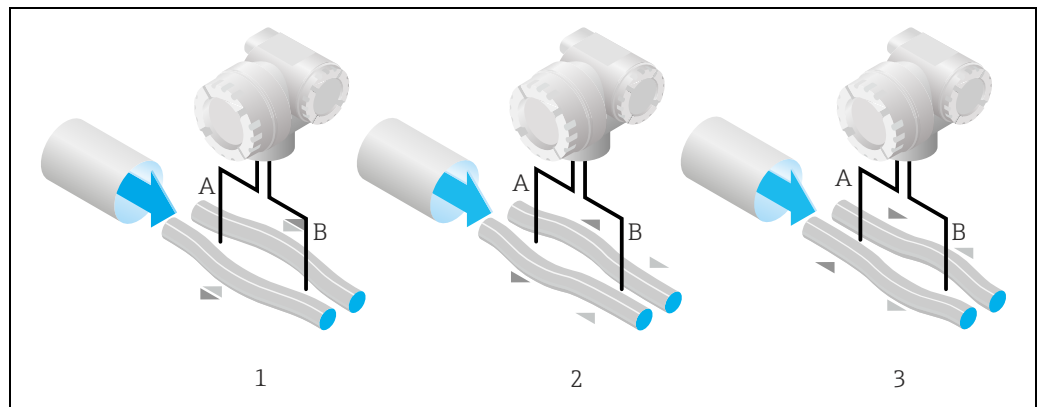

The phase difference (A-B) increases with increasing mass flow. Electrodynamical sensors register the tube oscillations at the inlet and outlet. System balance is ensured by the antiphase oscillation of the two measuring tubes. The measuring principle works independently of temperature, pressure, viscosity, conductivity and flow profile.

Density measurement

The measuring tubes are always excited at their resonance frequency. A change in the mass and thus the density of the oscillating system (comprising measuring tubes and fluid) results in a corresponding, automatic adjustment in the exciter frequency. Resonance frequency is thus a function of fluid density. The microprocessor utilizes this relationship to obtain a density signal.

Temperature measurement

To make calculations to compensate for temperature effects, the temperature of the measuring tubes is measured. This signal corresponds to the process temperature and is also available as an output signal.

Measuring system

The measuring system consists of a transmitter and a sensor, which form a mechanical unit.

Measuring system

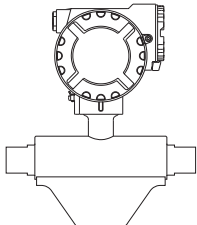
 <p style="text-align: center; font-size: small;">A0006979</p>	<ul style="list-style-type: none"> ▪ Without onsite operation ▪ Configuration via Modbus RS485 and FieldCare ▪ Maximum working pressure: 350 bar (5080 psi) ▪ Overpressure limit: 525 bar (7614 psi) ▪ Ambient temperature range: -40 to +60 °C (-40 to +140 °F)
---	---

Input

Measured variable

- Mass flow (proportional to the phase difference between two sensors mounted on the measuring tube to register a phase shift in the oscillation)
- Volume flow (calculated using mass flow and density)
- Fluid density (proportional to the resonance frequency of the measuring tube)
- Fluid temperature (measured with temperature sensors)

Measuring range

Measuring ranges for Compressed Natural Gas (CNG), non-custody transfer operation.

DN		$\dot{m}_{\min(F)}$ to $\dot{m}_{\max(F)}$	
[mm]	[in]	[kg/min]	[lb/min]
8	3/8"	0 to 30	0 to 66
15	1/2"	0 to 80	0 to 175
25	1"	0 to 150	0 to 330



Note!

The values of the corresponding custody transfer certificate apply for custody transfer operation.

Operable flow range

1:100

Output

Output signal**Pulse/frequency output**

- Passive
- Galvanically isolated
- Open Collector
- Max. 30 V DC
- Max. 25 mA
- Frequency output: end frequency 100 to 5000 Hz, on/off ratio 1:1, pulse width max. 2 s
- Pulse output: pulse value and pulse polarity selectable, pulse width configurable (0.1 to 1000 ms)

Status output

- Passive
- Open Collector
- Max. 30 V DC
- Max. 25 mA

Modbus RS485

- Modbus device type: slave
- Address range: 1 to 247
- Functions codes supported: 03, 04, 06, 08, 16, 23
- Broadcast: supported with the function codes 06, 16, 23
- Physical interface: RS485 in accordance with standard EIA/TIA-485
- Baud rate supported: 1200, 2400, 4800, 9600, 19200, 38400, 57600, 115200 Baud
- Transmission mode: RTU or ASCII
- Response time: typically 5 ms

Signal on alarm*Pulse/frequency output*

De-energized in the event of fault or power supply failure

Status output

De-energized in the event of fault or power supply failure

Modbus RS485

De-energized in the event of fault or power supply failure

Load

→ "Output signal"

Galvanic isolation

All circuits for outputs, and power supply are galvanically isolated from each other.

Power supply

Terminal assignment

Order characteristic for "inputs/outputs"	Terminal No. (outputs)		
	22 (+) / 23 (-)	24 (+) / 25 (-)	26 (+) / 27 (-)
Fixed communication board (permanent assignment)			
N	Pulse / frequency /status output 2	Pulse / frequency /status output 1	Modbus RS485

Supply voltage

24 V DC nominal voltage (10 to 30 V DC) / 24 V AC nominal voltage (20 to 28 V AC)

Power consumption

AC: < 4.0 VA

DC: < 3.2 W

Typical switch-on current at 24 V DC nominal voltage at $R_i = 0.1 \Omega$ of the source.

t [ms]	I [A]
0	10.0
0.1	8.0
0.2	7.5
0.5	7.0
1.0	6.0
2.0	4.0
5.0	1.5
10.0	0.125 (operating current)



Note!

The internal resistance of the source may not exceed $R_i = 10 \Omega$.**Power supply failure**

Lasting min. 20 ms.

All measuring cell and measuring point data are maintained.

Electrical connection

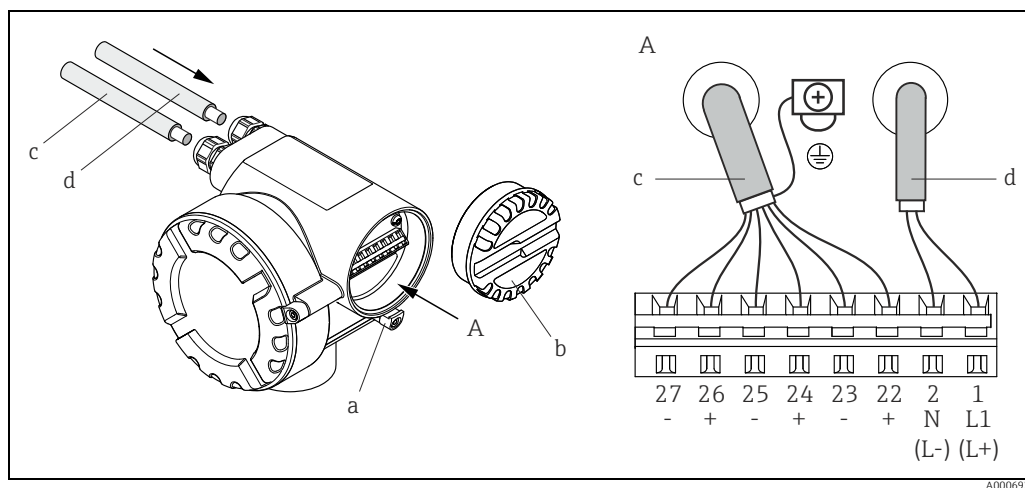

Connecting the transmitter, cable cross-section: max. 2.5 mm² (14 AWG)

A View A

- a Safety claw
- b Connection compartment cover
- c Signal cable: terminal Nos. 22 to 27
(shield is mandatory)
- d Cable for power supply: 20 to 28 V AC, 10 to 30 V DC
 - Terminal No. 1: L1 for AC, L+ for DC
 - Terminal No. 2: N for AC, L- for DC

Potential equalization

This measuring instrument is suitable for potentially explosive atmospheres; refer to the correspondingly information in the specific Ex-specific supplementary documentation.

Cable entries

Power supply and signal cables (outputs):

- Cable entry M20 × 1.5 (8 to 12 mm / 0.31 to 0.47")
- Threads for cable entries, ½" NPT, G ½"

Cable specifications

Each compatible cable, with a temperature specification at least +20 °C (+68 °F) higher than the ambient temperature prevailing in the application. We recommend using a cable with a temperature specification of +80 °C (+176 °F).

Modbus RS485 (cable type A):

- Characteristic impedance: 120 Ω
- Cable capacity: < 30 pF/m (< 9.2 pF/ft)
- Core cross-section: > 0.34 mm² (AWG 22)
- Cable type: twisted pairs
- Loop-resistance: ≤ 110 Ω/km (≤ 0.034 Ω/ft)
- Signal damping: max. 9 dB along the entire length of the cable cross-section
- Shield: Copper braided shielding or braided shielding and foil shielding

Performance characteristics

Reference operating conditions

Error limits following ISO/DIS 11631:

- Fluid: water
- 15 to 45 °C (59 to 113 °F); 2 to 6 bar (29 to 87 psi)
- Calibration rigs returned to national calibration standards
- Zero point calibrated under operating conditions
- Density adjustment carried out

To obtain measured errors, use the Applicator sizing tool *Applicator*: →  14.

Maximum measured error**Mass flow**

±0.5% of the quantity filled in typical CNG fueling.

Repeatability**Mass flow (gases)**

±0.25% of the quantity filled in typical CNG fueling.

Influence of medium temperature

When there is a difference between the temperature for zero point adjustment and the process temperature, the typical measured error is ±0.0003% of the full scale value / °C.

Influence of medium pressure

The following section shows the effect on accuracy of mass flow due to a difference between calibration pressure and process pressure is negligible.

Installation

Installation instructions

Note the following points:

- No special measures such as supports are necessary. The housing absorbs external forces.
- The high oscillation frequency of the measuring tubes ensures that the correct operation of the measuring system is not influenced by pipe vibrations.
- No special precautions need to be taken for fittings which create turbulence (valves, elbows, T-pieces etc.).

Inlet and outlet runs

There are no installation requirements regarding inlet and outlet runs.

Special installation instructions

Turning the transmitter housing

The transmitter housing can be rotated counterclockwise continuously up to 360°.

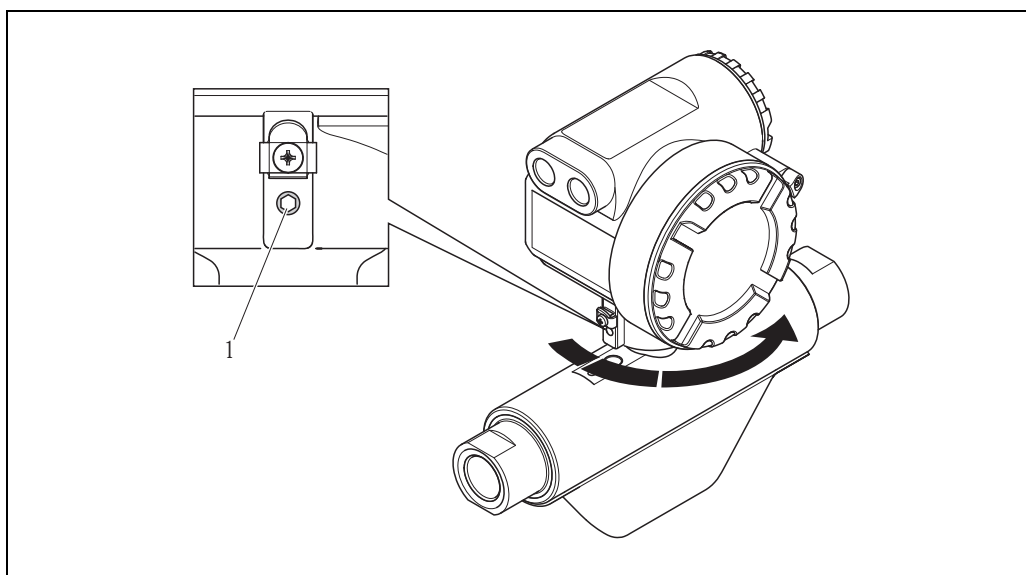

A0006921

1 = Allen screw

Rupture disk

Make sure that the function and operation of the rupture disk is not impeded through the installation of the device. The position of the rupture disk is indicated on a sticker applied over it. If the rupture disk is triggered, the sticker is destroyed. The disk can therefore be visually monitored. For additional information that is relevant to the process (→ 10).

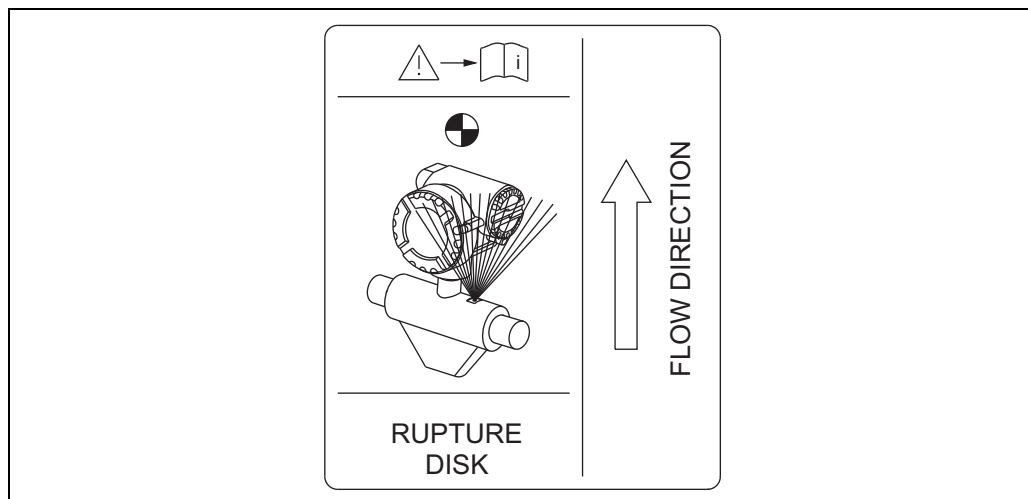

A0006921

Indication label for the rupture disk

Zero point adjustment

All measuring devices are calibrated accordance with state-of-the-art technology. Calibration takes place under reference conditions (→ 7). Therefore, a zero point adjustment in the field is generally **not** required.

If a zero point adjustment is desired, please note the following points before performing one:

- Adjustment can only be performed under stable pressure conditions.
- The zero point adjustment takes place at zero flow. This can be achieved, for example, with shutoff valves upstream and/or downstream of the sensor or by using existing valves and gates.
 - Normal operation → valves 1 and 2 open
 - Zero point adjustment *with* process pressure → Valve 1 open / valve 2 closed
 - Zero point adjustment *without* process pressure → Valve 1 closed / valve 2 open
- A zero point adjustment is **not** possible if the SECURITY function is enabled or if an error message is pending.

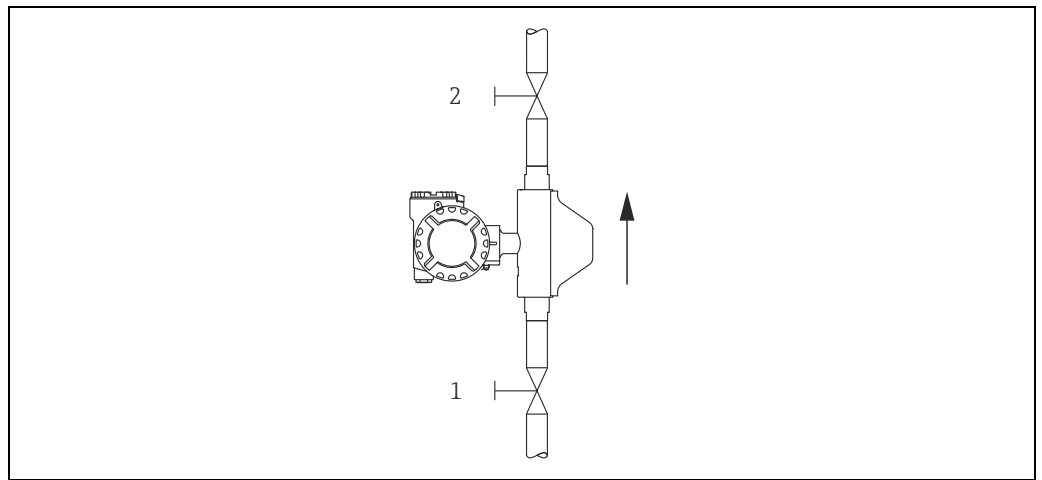

Zero point adjustment and shutoff valves

A0006928

Environment

Ambient temperature range	Sensor and transmitter: -40 to +60 °C (-40 to +140 °F)
!	Note! ▪ Install the device in a shady location. Avoid direct sunlight, particularly in warm climatic regions.
Storage temperature	-40 to +80 °C (-40 to +175 °F), preferably at +20 °C (+68 °F)
Degree of protection	Standard: IP 67 (NEMA 4X) for transmitter and sensor
Shock resistance	According to IEC/EN 60068-2-31 and EN 60721 (Class 2M3)
Vibration resistance	According to IEC/EN 60068-2-31 and EN 60721 (Class 2M3)
Electromagnetic compatibility (EMC)	As per IEC/EN 61326

Process

Medium temperature range -50 to +125 °C (-58 to +257 °F)

Maximum working pressure Measuring tubes, connector: 350 bar (5080 psi)

Pressure-temperature ratings **Process connection: Cylindrical internal thread BSP (G) in accordance with ISO 228-1**
Connection material: 1.4404 (316)

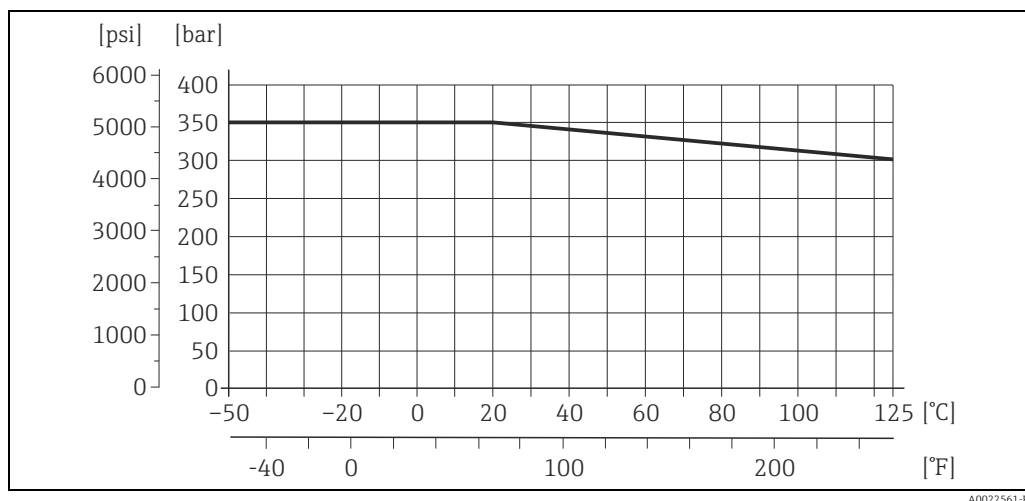

A0022561-EN

Rupture disk Triggering pressure in the housing: 10 to 15 bar (145 to 217.5 psi), → [8](#) "Special mounting instructions".

Pressure loss To calculate the pressure loss, use the *Applicator* sizing tool (→ [14](#)).

Limiting flow → [4](#), "Measuring range"

Mechanical construction

Design/dimensions

Field housing compact version (non-hazardous area II2G / zone 1)

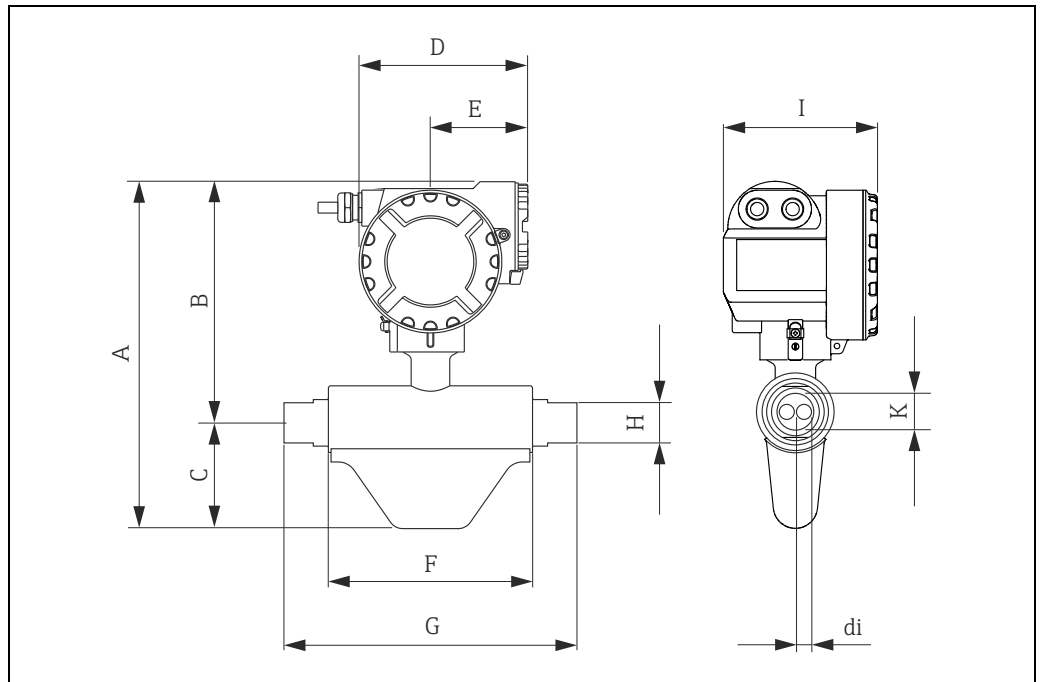

A0006968

Dimensions in SI units

DN	A	B	C	D	E	F	G	H	I	K	di
08	308	208	100	160	92	150	214	32	139	G $\frac{1}{2}$ "	3.87
15	308	208	100	160	92	193	267	41	139	G $\frac{3}{4}$ "	6.23
25	313	208	105	160	92	244	316	46	139	G1"	8.8

All dimensions in [mm]

Dimensions in US units

DN	A	B	C	D	E	F	G	H	I	K	di
$\frac{3}{8}$ "	12.1	8.2	3.9	6.3	3.6	5.9	8.4	1.3	5.5	G $\frac{1}{2}$ "	0.152
$\frac{1}{2}$ "	12.1	8.2	3.9	6.3	3.6	7.6	10.5	1.6	5.5	G $\frac{3}{4}$ "	0.245
1"	12.3	8.2	4.1	6.3	3.6	9.6	12.4	1.8	5.5	G1"	0.346

All dimensions in [in]

Weight

DN in mm (in)	08 ($\frac{3}{8}$ "	15 ($\frac{1}{2}$ "	25 (1"
Weight in kg (lb)	6.4 (14.1)	8.3 (18.3)	9.3 (20.5)

Material	<p><i>Transmitter housing:</i> Powder coated die-cast aluminium</p> <p><i>Sensor housing:</i> Acid-resistant and alkali-resistant external surface, stainless steel 1.4301 (304)</p> <p><i>Process connection:</i> Stainless steel 1.4404 (316)</p> <p><i>Measuring tubes:</i> Stainless steel 1.4435 (316L)</p>
-----------------	--

Process connections	<p>Cylindrical internal thread BSP (G) in accordance with ISO 228-1 with sealing surfaces in accordance with DIN 3852-2/ISO 1179-1:</p> <ul style="list-style-type: none"> ▪ G ½" for DN 08 ▪ G ¾" for DN 15 ▪ G 1" for DN 25 <p>! Note! Sealed with profile seal as in accordance with DIN 3869 or copper disk or steel seal disk with plastic lip.</p>
----------------------------	---

Operability

Local display	<p>Display element</p> <p>Status LED: There is a Light Emitting Diode (LED) on the meter electronics board that allows simple fault diagnostics.</p> <p>Control elements</p> <p>Device-internal DIP switch.</p>
----------------------	---

Remote operation	Operating via Modbus RS485 and serviceinterface FXA291 (e.g. FieldCare)
-------------------------	---

Certificates and approvals

CE mark	The measuring system is in conformity with the statutory requirements of the EC Directives. Endress+Hauser confirms successful testing of the device by affixing to it the CE mark.
C-Tick symbol	The measuring system meets the EMC requirements of the Australian Communications and Media Authority (ACMA).
Ex approval	Information about currently available Ex versions (ATEX, FM, CSA etc.) can be supplied by your Endress+Hauser sales office on request. All information relevant to explosion protection is available in separate Ex documents that you can order as necessary.
Approval for custody transfer	Information about currently available approvals for custody transfer can be supplied by your E+H Sales Center on request.
Modbus certification	The measuring device meets all the requirements of the Modbus/TCP conformity and integration test and has the "Modbus/TCP Conformance Test Policy, Version 2.0". The measuring device has successfully passed all the test procedures carried out and is certified by the "Modbus/TCP Conformance Test Laboratory" of the University of Michigan.

Pressure measuring device approval

The measuring devices can be ordered with or without PED (Pressure Equipment Directive). If a device with PED is required, this must be ordered explicitly. For devices with nominal diameters less than or equal to DN 25 (1"), this is neither possible nor necessary.

- With the identification PED/G1/III on the sensor nameplate, Endress+Hauser confirms conformity with the "Basic safety requirements" of Appendix I of the Pressure Equipment Directive 97/23/EC.
- Devices with this identification (with PED) are suitable for the following types of fluid:
 - Fluids of Group 1 and 2 with a steam pressure greater than, or smaller and equal to 0.5 bar (7.3 psi)
 - Unstable gases
- Devices without this identification (without PED) are designed and manufactured according to good engineering practice. They correspond to the requirements of Art. 3, Section 3 of the Pressure Equipment Directive 97/23/EC. Their application is illustrated in Diagrams 6 to 9 in Appendix II of the Pressure Equipment Directive 97/23/EC.

Other standards and guidelines

- EN 60529
Degrees of protection provided by enclosures (IP code)
- EN 61010-1
Safety requirements for electrical equipment for measurement, control and laboratory use
- IEC/EN 61326
"Emission in accordance with Class A requirements". Electromagnetic compatibility (EMC-requirements)
- EN 60721
Shock and vibration resistance
- OIML R139
Suitability for custody transfer measurement

Ordering Information

Detailed ordering information is available from the following sources:

- In the Product Configurator on the Endress+Hauser website: www.endress.com → Select country → Instruments → Select device → Product page function: Configure this product
- From your Endress+Hauser Sales Center: www.endress.com/worldwide



Note!

Product Configurator - the tool for individual product configuration

- Up-to-the-minute configuration data
- Depending on the device: Direct input of measuring point-specific information such as measuring range or operating language
- Automatic verification of exclusion criteria
- Automatic creation of the order code and its breakdown in PDF or Excel output format
- Ability to order directly in the Endress+Hauser Online Shop

Accessories

Various accessories, which can be ordered with the device or subsequently from Endress+Hauser, are available for the device. Detailed information on the order code in question is available from your local Endress+Hauser sales center or on the product page of the Endress+Hauser website:

www.endress.com.

Device-specific accessories**For the Transmitter**

Accessories	Description
Electronics module	Complete plug-in electronics module.

Service-specific accessories

Accessories	Description
Applicator	<p>Software for selecting and sizing Endress+Hauser measuring devices:</p> <ul style="list-style-type: none"> ■ Calculation of all the necessary data for identifying the optimum flowmeter: e.g. nominal diameter, pressure loss, accuracy or process connections ■ Graphic illustration of the calculation results <p>Administration, documentation and access to all project-related data and parameters over the entire life cycle of a project.</p> <p>Applicator is available:</p> <ul style="list-style-type: none"> ■ Via the Internet: https://wapps.endress.com/applicator ■ On CD-ROM for local PC installation
W@M	<p>Life cycle management for your plant.</p> <p>W@M supports you with a wide range of software applications over the entire process: from planning and procurement, to the installation, commissioning and operation of the measuring devices. All the relevant device information, such as the device status, spare parts and device-specific documentation, is available for every device over the entire life cycle. The application already contains the data of your Endress+Hauser device. Endress+Hauser also takes care of maintaining and updating the data records.</p> <p>W@M is available:</p> <ul style="list-style-type: none"> ■ Via the Internet: www.endress.com/lifecyclemanagement ■ On CD-ROM for local PC installation
FieldCare	<p>FieldCare is Endress+Hauser's FDT-based plant asset management tool and allows the configuration and diagnosis of intelligent field devices. By using status information, you also have a simple but effective tool for monitoring devices. The Proline flowmeters are accessed via a service interface or via the service interface FXA193.</p>
FXA291	<p>Service interface from the measuring device to the PC for operation via FieldCare.</p>

System components

Accessories	Description
Memograph M graphic display recorder	<p>The Memograph M graphic display recorder provides information on all the relevant process variables. Measured values are recorded correctly, limit values are monitored and measuring points analyzed. The data are stored in the 256 MB internal memory and also on a DSD card or USB stick. Memograph M boasts a modular design, intuitive operation and a comprehensive security concept. The ReadWin® 2000 PC software is part of the standard package and is used for configuring, visualizing and archiving the data captured. The mathematics channels which are optionally available enable continuous monitoring of specific power consumption, boiler efficiency and other parameters which are important for efficient energy management.</p>

Documentation

- Flow measurement (FA00005D)
- Operating Instructions incl. Device Functions (BA00123D)
- Ex-Supplementary documentation ATEX (II2G): (XA00115D)
- Ex-Supplementary documentation FM, CSA (Div. 1): (XA00116D)
- Ex-Supplementary documentation NEPSI (Zone 1, Zone 21): (XA00123D)

Registered trademarks

Modbus®

Registered trademark of the SCHNEIDER AUTOMATION, INC.

Applicator®, FieldCare®, HistoROM™, S-DAT®

Registered or registration-pending trademarks of the Endress+Hauser Group

www.addresses.endress.com
