

I/A Series[®] Intelligent Temperature Transmitter
Model RTT20 Transmitter with Analog 4 to 20 mA Output or
HART Communication Protocol



The Model RTT20 Intelligent Temperature Transmitter receives input signals from RTDs, thermocouples, ohms sensors, or dc mV sources. It transmits a 4 to 20 mA output (with no remote communications), a smart version with HART communications, or an intelligent version with software selectable 4 to 20 mA. Remote communication and database configuration is provided by a hand-held communicator, a PC-based configurator, or an I/A Series System.

FEATURES

- ▶ 4 to 20 mA, HART
- ▶ Field-proven microprocessor-based transmitter
- ▶ Superior Accuracy
- ▶ Long-Term Stability
- ▶ Multiple Packaging Configurations offered, including Pipe or Surface Mounting, DIN Rail Mounting, Integral Bare Sensor, and Integral Sensor with Thermowell
- ▶ One Unit Configurable for all T/C, RTD, mV, Ohm, and Dew Point Inputs. Custom Inputs can also be accommodated.
- ▶ Available as a Basic Unit, or in Aluminum or 316 ss Enclosure. Enclosure is Explosionproof and meets NEMA Type 4X and IEC IP65.
- ▶ Automatic Self-Diagnostics and Self-Calibration
- ▶ Configurable Failsafe Value
- ▶ Optional Three-Line Integral, Plug-in LCD Indicator/Configurator
- ▶ Wide Selection of Thermowell Configurations
- ▶ RFI, Voltage Surge, and Reverse Polarity Protection
- ▶ Conforms to Applicable European Union Directives (Product marked with “CE” Logo)
- ▶ NAMUR Compliant Failure Current
- ▶ Transmitter complies with EMC (ElectroMagnetic Compatibility) Directives
- ▶ Approved/Certified by many Testing Agencies for Hazardous Area Installations
- ▶ Standard 2-Year Warranty

GENERAL DESCRIPTION

The RTT20 provides a wide range of packaging, sensor types, and options along with three choices of output signals, 4 to 20 mA, smart HART, and Intelligent, making this transmitter suitable for virtually all temperature measurement applications. The microprocessor-based electronics eliminates ambient temperature effects and results in high accuracy, repeatability and linearization of the sensor signal. Ease of mounting and installation makes these transmitters an extremely attractive offering.

INTELLIGENT TRANSMITTER FAMILY

The RTT20 Temperature Transmitter is designed for single measurements, but can be configured for dual 2-wire RTDs. However, for dual thermocouples, or dual 3- or 4-wire RTDs, the Model RTT25 is the correct choice. The Model RTT25 Temperature Transmitter is available with FOUNDATION Fieldbus Communication Protocol (refer to PSS 2A-1F4 C).

EFFICIENT AND DURABLE

Industrial-grade integrated circuits and sealed electronics combine to make this microprocessor-based transmitter an efficient and durable device.

MULTIPLE PACKAGING CONFIGURATIONS

The transmitter (Figure 1) is suitable for use in a variety of applications. Transmitters with integrally mounted sensor have an environmentally protected enclosure and are mounted directly to the process. Surface- and pipe-mounted configurations allow the transmitter to be mounted remotely from the process. The transmitter is also available with DIN-mounting hardware, and as a basic transmitter package. Built-in protection from vibration and radio frequency interference (RFI) are also provided.

Figure 1. Multiple Packaging Configurations

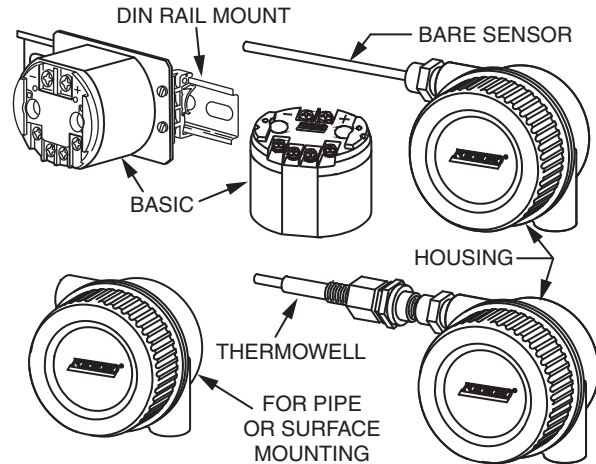

REMOTE COMMUNICATIONS

This high-performance temperature transmitter can be ordered with or without remote communications, making it ideal for use in new process applications and for upgrading existing applications. Remote communication is available with HART communication protocol.

INPUT TYPES

This RTT20 Intelligent Temperature Transmitter can be used with a wide variety of temperature sensors, including two, three, and four-wire RTDs, all popular thermocouples, and other resistance and millivolt input devices. The following is a general list of transmitter input types:

- ▶ Platinum RTDs
- ▶ Nickel RTDs
- ▶ Copper RTDs
- ▶ Differential RTDs
- ▶ Thermocouples
- ▶ Millivolts
- ▶ Ohms
- ▶ Dew Point
- ▶ Custom

OUTPUT TYPES AND REMOTE CONFIGURATION

The transmitter provides a 4 to 20 mA or digital output linear with temperature (°F, °C, K, or °R), linear with input (mV, ohms, or mA), or linear with Dew Point. The internal, or an external Cold Junction (CJ) sensor automatically compensates thermocouple measurements. When configured with HART output, four HART outputs can be provided to the host control system. The HART output can be configured for Burst Mode or Multidrop operation. The transmitter can be locally or remotely reconfigured as follows:

- ▶ **4 to 20 mA:** Local configuration via optional integral three-line LCD Indicator/Configurator. No remote communications.
- ▶ **4 to 20 mA with HART Communication Protocol:** Local configuration via optional integral three-line LCD Indicator/Configurator. Remote configuration using HART Communicator or Foxboro PC-based Configurator.

LCD INDICATOR/CONFIGURATOR OPTION

This versatile three-line Indicator plugs into the top of the transmitter (see Figure 2) and provides the following features:

- ▶ **Local Configuration** – Indicator has two pushbuttons to rerange or reconfigure the transmitter database without using a separate configurator. Menu messages are configurable in English, French, German, or Spanish.
- ▶ **Highly Accurate** – Indicator is microprocessor driven, thereby eliminating any D/A conversion error caused by the 4 to 20 mA output signal.
- ▶ **Non-Interactive** – Transmitter output is unaffected whether inserting or removing the indicator, reading parameters, or downloading data; or by indicator failure.
- ▶ **Portable** – A single indicator can be used for multiple transmitters. No tools are required to install or remove it. Simply plug it in, make desired readings and/or adjustments to the transmitter, unplug the indicator, and install it in the next transmitter.
- ▶ **One Indicator** – The same indicator is used regardless of transmitter output.

- ▶ **Custody Transfer/Security** – Provided for HART version, the pushbuttons can be disabled via the remote configurators.
- ▶ **Highly Visible Measurement Display** – Top line of this 3-Line Indicator has six 8 mm (0.31 in) high digits. The indicator displays negative values with a minus sign.
- ▶ **Innovative 3-Line Indicator** – The second line of this indicator is an eleven-segment bargraph that displays readings in percent of calibrated range. Temperatures outside the calibrated range are indicated by a left-pointing (underrange) or right-pointing (overrange) arrow. The third line displays a user-configurable tag number on a 6 mm (0.25 in) high, seven-character, alphanumeric display. This line also automatically displays the following fault messages:
 - ▶ FAILSAFE – transmitter or sensor failure
 - ▶ D FAIL (Display FAIL) – temperature exceeds the limit of the display
- ▶ **Configurable Display** – The top line of the Indicator displays the output in any one of five different ways:
 - ▶ Engineering Units (EGU)
 - ▶ mA, or mA and EGU
 - ▶ %, or % and EGU

Figure 2. LCD Indicator/Configurator Option

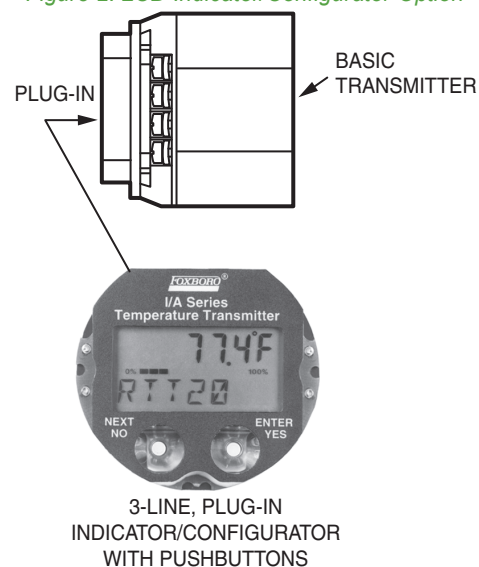

AUTOMATIC SELF-CALIBRATION

This transmitter has an advanced automatic self-calibration routine that greatly extends the time between recalibrations. Every three seconds, the transmitter checks the zero and full scale output against highly accurate and stable internal voltage signals that are referenced back to the factory calibration stored in non-volatile EEPROM memory. Any necessary adjustments are made automatically without interrupting the output signal.

NAMUR COMPLIANT FAILURE CURRENT

The transmitter's current output is linear between 3.8 to 20.75 mA. But the failsafe current is adjustable between 3.6 to 3.8 mA for a failsafe-low condition, or from 20.75 to 23 mA for a failsafe-high condition. By having the failsafe current different from the out-of-range current, determining whether the transmitter is in a failsafe condition, or just the process temperature is beyond the calibrated range, is quick and easy without the use of a configurator tool.

INSTALLATION ASSISTANT

When you order a transmitter with an integral sensor and thermowell, everything is assembled, tagged, wired, calibrated, and configured to your specifications. Just open the shipping container and install. This feature is ordered by specifying Model Code Package Configuration Code "L" or "M," along with Option "-D2." See Figure 3.

REAL WORLD PERFORMANCE

The transmitter nonvolatile memory stores many coefficients to eliminate errors. Every transmitter is factory tested from -40 to +85°C (-40 to +185°F) ambient temperature, and the error coefficients, along with the curves for all sensor types, are stored in the nonvolatile memory. Therefore, the accuracy specification is applicable merely by choosing the sensor type and calibrated range, without the need for any calibration equipment.

In addition, the internal cold junction sensor not only compensates for a thermocouple measurement, but its temperature is used to compensate any ambient temperature error, no matter what sensor type is selected.

FAILSAFE MODE

Transmitter failsafe operation is user-configurable as either ON or OFF. The failsafe output is user configurable for any value between 3.60 and 3.80 mA (downscale failsafe) or 20.75 and 23.00 mA (upscale failsafe). Every three seconds, the transmitter checks for open or shorted sensor leads and for internal transmitter faults. If two successive faults are reported while failsafe is ON, the transmitter output will default to the configured failsafe value.

The transmitter underrange and overrange currents have been set to 3.80 and 20.75 mA, respectively, which are inside the failsafe value. This makes troubleshooting quick and easy because the mA failsafe current will be different than an out-of-range condition.

With HART communication, the transmitter reset mode is also user-configurable. When configured for AUTO reset, the transmitter automatically returns to normal operation after the fault has been eliminated. With LATCHED reset, transmitter power must be turned off, then back on to return to normal operation.

Figure 3. RTT20 with Integral Sensor with Thermowell

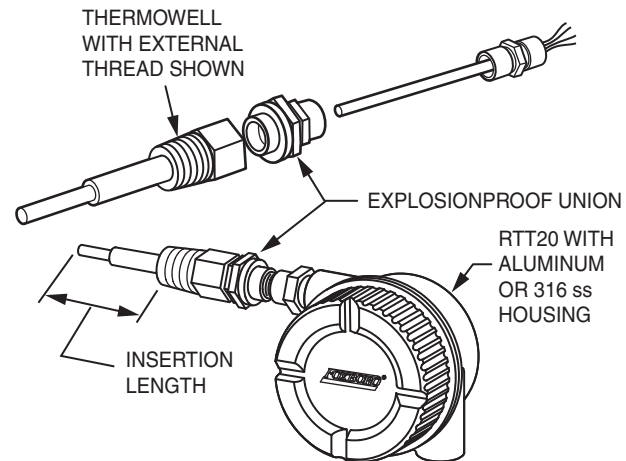

CONFIGURATION STORAGE

All configurable parameters are stored in nonvolatile EEPROM memory and retained when power is removed from the transmitter. The transmitter is ready for immediate use when repowered.

Configured data from the Intelligent version can also be stored offline in a Hand-Held Terminal Memory Pak, on a floppy disk (using PC-based configurator software), or in an I/A Series system allowing other transmitters to be easily cloned or configured. This data can be factory-customized by ordering Option Code “-C2”. It can also be supplied on a floppy disk by ordering Option Code “-C3”.

INTELLIGENT SMOOTHING

Innovative Intelligent Smoothing automatically eliminates noise while maintaining fast response to rapid input changes. It provides a highly accurate

and smooth output signal without the need for excessive damping. A digital filtering algorithm (signal conditioner) is active over a band of input fluctuations. Any noise (process or electrical) is eliminated while the conditioned signal reacts immediately to any input change that exceeds the smoothing band. This allows the transmitter to be used in a wide variety of electrically noisy installations.

When there is a rapid signal change, the smoothing band is immediately exceeded, and the output of the signal conditioner uses this change as the basis for the output signal. As long as the input fluctuates or moves at a rate that is outside the smoothing band, the output instantly tracks the input signal. Once the input settles at a new value, the filtering algorithm is automatically reactivated, eliminating noise and producing an accurate and stable output.

OPERATING, STORAGE, AND TRANSPORTATION CONDITIONS

Influence	Reference Operating Conditions	Operative Limits	Storage and Transportation Limits
Ambient Temperature Without Integral Display	24 ±2°C (75 ±3°F)	-40 and +85°C (a) (-40 and +185°F) (a)	-54 and +85°C (-65 and +185°F)
With Integral Display	24 ±2°C (75 ±3°F)	-29 and +70°C (a) (-20 and +158°F) (a)	-54 and +85°C 65 and +185°F)
Relative Humidity	50 ±10%	0 and 100% (noncondensing)	0 and 100% (noncondensing)
Supply Voltage	30 ±0.5 V dc	12 and 42 V dc	Not Applicable
Vibration	Negligible	19 mm (0.75 in) Double Amplitude from 5 to 9 Hz 0 to 30 m/s ² (0 to 3 “g”)(b) from 9 to 500 Hz	1070 mm (42 in) Drop in Shipping Container

PERFORMANCE SPECIFICATIONS

(Under Reference Operating Conditions Unless Otherwise Specified)

Accuracy

Refer to Table 1. The accuracy specification is applicable merely by choosing a sensor type and calibrated range without the need for any calibration equipment.

Repeatability and Linearity

Included in accuracy.

Long-Term Stability

DIGITAL OUTPUT:

<0.05% of input reading (mV or Ω) per year

4 to 20 mA OUTPUT:

Digital Stability plus 0.043% of span per year.

Vibration Effect

<0.05% at 30 m/s² (3 g)

Ambient Temperature Effect

Error is less than 1/2 the reference accuracy plus 0.1°C per 28°C (50°F)

Relative Humidity Effect

<0.01% of calibrated span from 0 to 100% RH, noncondensing.

Mounting Position Effect

None

Supply Voltage Effect

DIGITAL OUTPUT: None

4 to 20 mA OUTPUT: \leq 0.005% per volt

Output Load Effect

DIGITAL OUTPUT: None

4 to 20 mA OUTPUT: \leq 0.005% per volt

PHYSICAL SPECIFICATIONS

Basic Transmitter (Package Code B)

Enclosed in polycarbonate material

Enclosure Construction

HOUSING (Package Codes S, W, L):

Epoxy-coated, low-copper aluminum

HOUSING (Package Codes T, Y, M):

316 ss (CF-8M/UNS-J92900)

HOUSING COVER O-RING

UV Stabilized Buna-N

Union Coupling for Thermowell Mount

- ▶ Zinc-Plated Steel for Foxboro Code “L” housing, or with user-supplied thermowell option “-D5” (Codes “L” or “M” housing). See Model Code.
- ▶ Stainless Steel for Foxboro Code “M” housing, or with Option “-H2”. See Model Code.

Environmental Protection

Housing: NEMA Type 4X, IP65

Mounting Options

Option	Code	Bracket	Hardware
Mounting Set	-M1	Epoxy-Coated Steel	Plated Steel
	-M2	Stainless Steel	Stainless Steel
DIN Rail	-D1	Aluminum and Plastic	Plated Steel

Approximate Transmitter Mass

BASIC: 0.13 kg (0.28 lb)

SURFACE MOUNT (Aluminum): 1.47 kg (3.25 lb)

SURFACE MOUNT (316 ss): 3.25 kg (7.25 lb)

WITH 1-LINE INDICATOR: Add 0.02 kg (0.05 lb)

WITH 3-LINE INDICATOR: Add 0.06 kg (0.13 lb)

FUNCTIONAL SPECIFICATIONS

Input Types and Range Limits

See Table 1 and Table 2.

Input Impedance (in mV Input Mode)

>10 MΩ

Span Limits

MINIMUM: 5°C (10°F)

MAXIMUM: See Table 1.

Engineering Units

The transmitter electronic database can be configured for ohms, mV, mA, °F, °C, K, or Dew Point.

Output Types

- ▶ 4 to 20 mA
- ▶ Smart HART

Output

RANGING:

Zero and span adjustment are non-interacting.

FAILSAFE (User-Configurable):

Downscale: 3.6 to 3.8 mA

Upscale: 20.75 to 23.0 mA

UNDERRANGE CURRENT: 3.8 mA

OVERRANGE CURRENT: 20.75 mA

ACTION: Direct or Reverse

Table 1. Range Limits, Maximum Span, and Accuracy (a)

Input Type	Model Code	See Note	Range Limits		Maximum Span		Digital Accuracy (b) (c)	
			°C	°F	°C	°F	°C	°F
RTD (2, 3, or 4 wire)								
Pt100 DIN/IEC	Q	(d)	-200 and +850	-328 and +1562	1050	1890	±0.05	±0.09
Pt100 DIN/IEC	A	(e)	-200 and +850	-328 and +1562	1050	1890	±0.05	±0.09
Pt100 SAMA	P	(f)	-200 and +650	-328 and +1202	850	1530	±0.05	±0.09
Ni 200	D	(g) (h)	-130 and +315	-202 and + 599	445	801	±0.44	±0.79
Ni 120, Minco	G	(h)	-80 and +320	-112 and + 608	400	720	±0.03	±0.05
Ni 100	I	(h) (i)	-60 and +250	-76 and +482	310	558	±0.04	±0.07
Cu 10	F	(h) (j)	-70 and +150	-94 and +302	220	396	±0.51	±0.92
Thermocouple								
Type B	B	(k) (l)	0 and +1820	+32 and +3308	1820	3276	±0.51	±0.92
Type C	C	(k) (m)	0 and +2320	+32 and +4208	2320	4176	±0.38	±0.68
Type E	E	(k)	-270 and +1000	-454 and +1832	1270	2286	±0.08	±0.14
Type J	J	(k)	-210 and +1200	-346 and +2129	1410	2538	±0.11	±0.20
Type K	K	(k)	-270 and +1372	-454 and +2502	1642	2956	±0.14	±0.25
Type L	L	(m)	-200 and +900	-328 and +1652	1100	1980	±0.13	±0.23
Type N	N	(k)	-270 and +1300	-454 and +2372	1570	2862	±0.15	±0.27
Type R	R	(k)	-50 and +1768	-58 and +3214	1818	3272	±0.42	±0.76
Type S	S	(k)	-50 and +1768	-58 and +3214	1818	3272	±0.49	±0.88
Type T	T	(k)	-270 and +400	-454 and +752	670	1206	±0.10	±0.18
Type U	U	(m)	-200 and +600	-328 and -1112	800	1440	±0.09	±0.16
Other								
Millivolt	M	–	-15 and +115 mV dc		130 mV dc		±6 mV	
Resistance	O	–	1 and 500 Ω		500 Ω		±20 mΩ	
Dew Point	W	(h)	-45 and +60°C (-50 and +140°F)		105°C (190°F)		±0.05°C (0.09°F)	
Custom	Z	(h)	2- to 22-point user-configurable curve					

- a. For 4 to 20 mA output accuracy, add ±0.05% of span to digital accuracy.
- b. Digital accuracy is either the listed value or ±0.01% of span, whichever is greater. For thermocouples only, add the applicable cold junction error to digital accuracy:
Integral: ±0.2°C (±0.5°F)
Remote: Depends on accuracy of remote sensor.
- c. Does not include sensor accuracy.
- d. IEC/DIN 751; alpha = 0.00385 (1984) ASTM-B Standard Accuracy.
- e. IEC/DIN 751; alpha = 0.00385 (1984) ASTM-A High Accuracy.
- f. SAMA Standard RC 21-4; alpha = 0.003923.
- g. Foxboro NR 226/227. Refer to TI 005-24a.
- h. Not accessible with optional LCD Indicator/Configurator.
- i. DIN 43760.
- j. Foxboro CR 228/229. Refer to TI 005-25a.
- k. NIST Monogram 125, DIN IEC 584.
- l. May exhibit a decrease in performance at temperatures below 43°C (109°F).
- m. Tungsten 5% Rhenium-Tungsten 26%.

Table 2. Input Types

Single Sensor Type	Analog, 4 to 20 mA Output Code “-I”	HART Output Code “-T”
T/C Type B, C, E, J, K, L, N, R, S, T, U	YES	YES
RTD (2, 3, or 4 wire) 100 ohm DIN or SAMA	YES	YES
RTD (2, 3, or 4 wire) 100, 120, or 200 ohm nickel	NO	YES
RTD (2, 3, or 4 wire) 10 ohm copper	NO	YES
Millivolt	YES	YES
Ohms (2, 3, or 4 wire)	YES	YES
Dew Point	NO	YES
2 to 22 Point Custom Curve	NO	YES

Supply Voltage Requirements and External Loop Load Limitations

Figure 4. Supply Voltage vs. Output Load

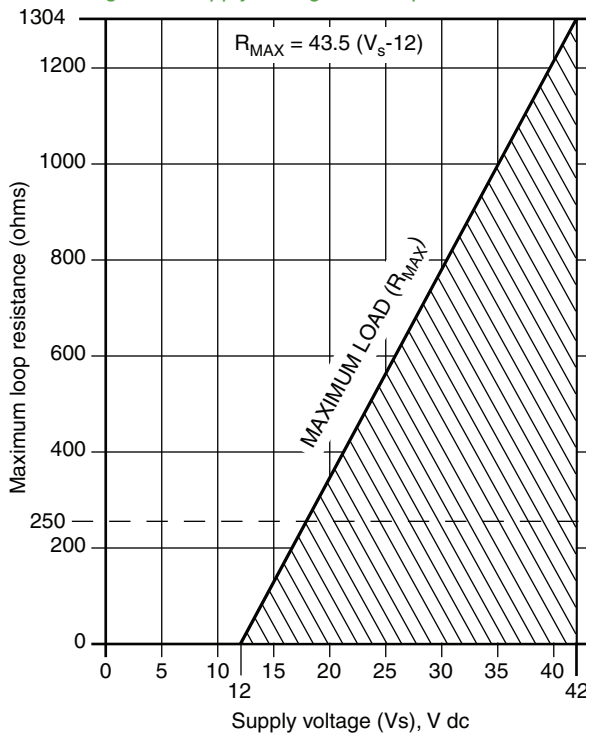

NOTE (See Figure 4)

- 1 Minimum load with HART communicator or PC-Based Configurator connected is 250 Ω.
- 2 Connecting PC-based Configurator or HART Communicator while operating below the minimum specified load may cause communication problems.

Output Update Rate

4 to 20 mA: 6 times per second (all output versions)
HART DIGITAL: 2 times per second

Input Response Time

With minimum damping, the 90% response time for an 80% input step is 1.2 seconds.

Isolation

500 V ac, rms

RFI Protection

Susceptibility radiated

- ▶ In metal housing
 - 30 V/m Peak; 26-1000 MHz; 80% A @ 1k Hz
 - 30 V/m Peak; 900 MHz; 50% duty cycle; 200 Hz repetition rate
- ▶ basic transmitter
 - 10 V/m Peak; 26-1000 MHz; 80% A @ 1k Hz
 - 10 V/m Peak; 900 MHz; 50% duty cycle; 200 Hz repetition rate

Two-Wire Transmitter

The same two wires are used for input power, output signal, and remote communication.

Turn On Time

TWO-WIRE SENSOR: 3.5 seconds

THREE- AND FOUR-WIRE SENSORS: 7 seconds

Minimum Power Supply Current

35 mA

Electronic Damping

4 to 20 mA VERSION:

1.2 seconds

HART VERSION:

Damping is set as a floating decimal point value between 0 and 32 seconds.

Tagging - Hardware and Software

The permanently embossed stainless steel data plate and the transmitter electronic tag number are factory configured, at no charge, using the customer supplied tagging information.

Configurators**4 to 20 mA Version Code -I:**

All configurable parameters can only be changed using the optional one-line or three-line indicator/configurators (Option Code -L1 or -L3).

HART Version Code -T:

All parameters are configurable via the HART Communicator or the Foxboro PC-Based Configurator. The integral indicator/configurators (Option -L3) can also be used to reconfigure the common parameters. Refer to MI 020-461 for details on the optional indicator/configurator.

Configurable Parameters (by the User)**DESCRIPTORS**

- ▶ Tag Number
- ▶ Tag Name
- ▶ Location
- ▶ Device Name
- ▶ Message

OUTPUT

- ▶ Output Type
- ▶ Engineering Units (EGU)⁽¹⁾
- ▶ Burst Mode (HART Only)
- ▶ Linearization Mode

INPUT

- ▶ Input Type (Refer to Table 2)⁽¹⁾
- ▶ Lower Range Value (LRV)⁽¹⁾
- ▶ Upper Range Value (URV)⁽¹⁾
- ▶ Cold Junction
- ▶ Cold Junction EGU

OTHER

- ▶ Sensor Fault Detection (On/Off)⁽¹⁾
- ▶ Failsafe (On/Off)⁽¹⁾
- ▶ Failsafe direction (Upscale/Downscale)⁽¹⁾
- ▶ Failsafe Value
- ▶ Failsafe Reset (Auto/Locked) (HART Only)
- ▶ Power Supply Frequency (50/60 Hz)
- ▶ Power Supply Filter (Standard/High)
- ▶ Damping
- ▶ Sensor Validation
- ▶ Intelligent Smoothing Time
- ▶ Calibrator's Initials
- ▶ mA Output Calibration⁽¹⁾

1. Accessible with the Optional LCD Indicator/Configurator.

INTEGRAL LCD INDICATOR/CONFIGURATOR

- ▶ Pushbuttons (Enable/Disable)
- ▶ Language⁽¹⁾
- ▶ Output Display Units (EGU, %, mA, Alternating EGU/mA, or Alternating %/mA)

RTT20 Transmitter Functional Block Diagram

Refer to Figure 5.

Figure 5. RTT20 Transmitter Functional Block Diagram

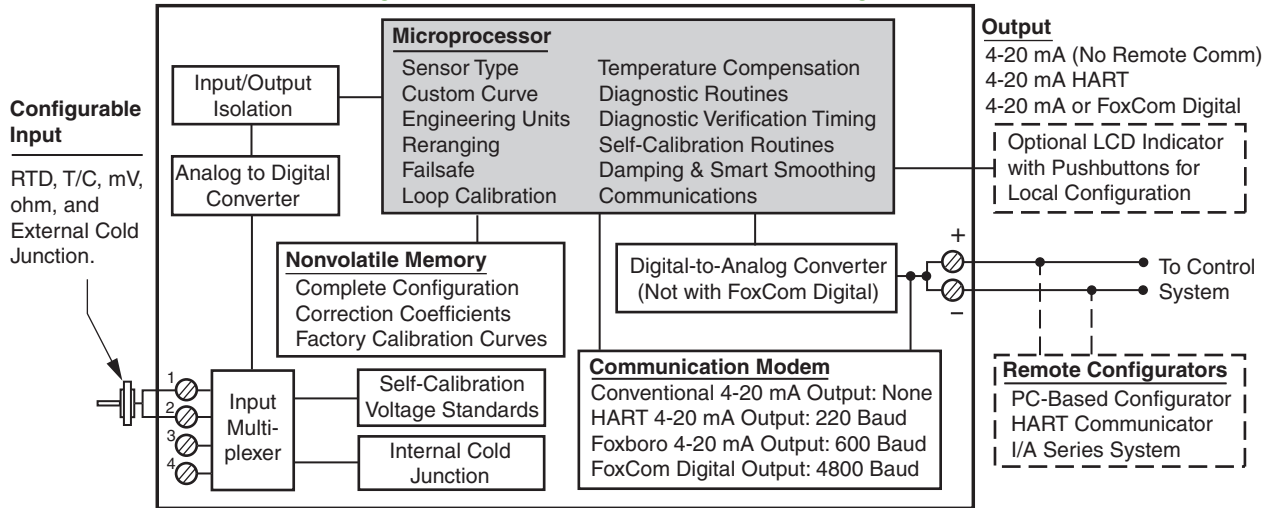

ELECTRICAL SAFETY SPECIFICATIONS

Testing Laboratory, Type of Protection, and Area Classification	With Package Config. Codes	Application Conditions	Electrical Safety Design Code
ATEX (FM) flameproof, II 1/2 G, Ex d, IIC.	S, T, L, M	Temperature Class T6. Ta = -40 to +70°C	ED
ATEX (FM) flameproof, II 2 G, Ex d, IIC.	W, Y	Temperature Class T6. Ta = -40 to +70°C	
ATEX (FM) flameproof, II 2 D.	S, T, L, M, W, Y	T85°C, Ta = -40 to 70°C maximum ambient.	
CENELEC (KEMA) intrinsically safe EEx ia, IIC, Zone 0.	All	Temperature Class T4 - T6.	EA
CENELEC (KEMA) Nonsparking/nonincendive, Ex N IIC	All	Temperature Class T4 - T6.	KN

Testing Laboratory, Type of Protection, and Area Classification	With Package Config. Codes	Application Conditions	Electrical Safety Design Code
CSA intrinsically safe, Class I, Division 1, Groups A, B, C, and D.	B	Temperature Class T4 at 85°C and T6 at 40°C maximum ambient.	CA
CSA intrinsically safe, Class I, Division 1, Groups A, B, C, and D; dust-ignitionproof, Class II, Division 1, Groups E, F, and G; and Class III, Division 1.	S, T, L, M, W, Y	Temperature Class T4 at 85°C and T6 at 40°C maximum ambient.	
CSA Class I, Division 2, Groups A, B, C, and D.		Temperature Class T4 at 85°C and T6 at 40°C maximum ambient.	
CSA explosionproof, Class I, Division 1, Groups B, C, and D; dust-ignitionproof, Class II, Division 1, Groups E, F, and G; and Class III, Division 1.	S, T, L, M, W, Y	Connect to source not exceeding 42 V. Temperature Class T4 at 85°C and T6 at 40°C maximum ambient.	CD (a)
CSA Class I, Division 2, Groups A, B, C, and D.		Temperature Class T4 at 85°C and T6 at 40°C maximum ambient.	
CSA Class I, Division 2, Groups A, B, C, and D.	All	Temperature Class T4 at 85°C and T6 at 40°C maximum ambient.	CN
FM intrinsically safe, Class I, Division 1, Groups A, B, C, and D.	B	Temperature Class T6; T4 at 85°C maximum ambient.	FA
FM intrinsically safe, Class I, Division 1, Groups A, B, C, and D; dust-ignitionproof, Class II, Division 1, Groups E, F, and G; and Class III, Division 1.	S, T, L, M, W, Y	Temperature Class T6; T4 at 85°C maximum ambient.	
FM nonincendive, Class I, Division 2, Groups A, B, C, and D; Class II, Division 2, Groups F and G; and Class III, Division 2.		Temperature Class T4 at 85°C and T6 at 40°C maximum ambient.	
FM explosionproof, Class I, Division 1, Groups B, C, and D; dust-ignitionproof, Class II, Division 1, Groups E, F, and G; and Class III, Division 1.	S, T, L, M, W, Y	Temperature Class T4 at 85°C and T6 at 40°C maximum ambient.	FD (a)
FM nonincendive, Class I, Division 2, Groups A, B, C, and D; Class II, Division 2, Groups F and G; and Class III, Division 2.		Temperature Class T4 at 85°C and T6 at 40°C maximum ambient.	
FM nonincendive, Class I, Division 2, Groups A, B, C, and D.	B	Temperature Class T4 at 85°C and T6 at 40°C maximum ambient.	FN
FM nonincendive, Class I, Division 2, Groups A, B, C, and D; Class II, Division 2, Groups F and G; and Class III, Division 2.	S, T, L, M, W, Y	Temperature Class T4 at 85°C and T6 at 40°C maximum ambient.	
IECEx flameproof, Ex d IIC.	S, T, L, M, W, Y	Temperature Class T6 at 70°C.	VV

a. FM approval and CSA certification of the Model RTT20 for the explosionproof rating listed above included pressure piling tests with various lengths of conduit to ensure that conduit seals per NEC 501-5(a)1 within 457 mm (18 inches) of the housing are not required.

MODEL CODE

BASIC UNIT TRANSMITTER - REMOTE SENSORS NOT PROVIDED WITH THESE TRANSMITTERS

<u>Description</u>	<u>Model</u>
I/A Series Intelligent Temperature Transmitter	RTT20
<u>Output Signal and Communication Protocol</u> 4 to 20 mA only; no Remote Communication (a) 4 to 20 mA with HART Communication (b)	-I -T
<u>Input Configuration</u> Single Input Channel	1
<u>Package Configuration and Housing Material (Remote Mounted Sensor)</u> Basic Unit (used for Panel Mount, DIN Rail, or Replacement)	B
<u>Sensor Length</u> None (Not Applicable to Transmitters with Remote Mounted Sensors)	N
<u>Measurement Input Type (Software Selectable)</u> None - Specified Factory Default to Code Q Thermocouple, Type B, Platinum - 30% Rhodium vs. Platinum - 6% Rhodium Thermocouple, Type C, Tungsten - 5% Rhenium vs. Tungsten - 26% Rhenium Thermocouple, Type E, Nickel-Chromium vs. Copper-Nickel (Chromel-Constantan) Thermocouple, Type J, Iron vs. Copper-Nickel (Iron-Constantan) Thermocouple, Type K, Nickel-Chromium vs. Nickel-Aluminum (Chromel-Alumel) Thermocouple, Type L, Iron vs. Copper-Nickel Thermocouple, Type N, Nicrosil vs. Nisil (Nicrosil-Nisil) Thermocouple, Type R, Platinum - 13% Rhodium vs. Platinum Thermocouple, Type S, Platinum - 10% Rhodium vs. Platinum Thermocouple, Type T, Copper vs. Copper-Nickel (Copper-Constantan) Thermocouple, Type U, Copper vs. Copper-Low Nickel RTD, Platinum, DIN, 100 Ω, IEC 751 (ASTM-B Standard Accuracy) RTD, Platinum, DIN, 100 Ω, IEC 751 (ASTM-A High Accuracy) RTD, Platinum, 100 Ω, SAMA RTD, Nickel, 200 Ω, Foxboro NR 226/227 RTD, Nickel, 120 Ω, Minco RTD, Nickel, 100 Ω, DIN 43760 RTD, Copper, 10 Ω, Foxboro CR 228/229 Millivolt Input Ohms Input Dew Point Input Custom Input	X B C E J K L N R S T U Q A P D G I F M O W Z
<u>Electrical Safety (Also see "ELECTRICAL SAFETY SPECIFICATIONS" on page 11 for further details)</u> CSA, Intrinsically Safe CSA, Division 2 CENELEC (KEMA) Intrinsically Safe FM, Intrinsically Safe and nonincendive FM, Nonincendive CENELEC (KEMA) nonsparking/nonincendive	CA CN EA FA FN KN
<u>Optional Selections</u> Refer to "MODEL CODE" on page 20.	

- a. With Output Code "-I", transmitter adjustment and output reconfiguration is possible only via an LCD Indicator/Configurator (Optional Selection "-L3") which is easily transportable between transmitters. Remote communication is not available.
- b. Remote configuration with HART Communicator, Foxboro PC-based Configurator, and/or Foxboro ABO991 software.

MODEL CODE

SURFACE OR PIPE MOUNT TRANSMITTER - REMOTE SENSORS NOT PROVIDED WITH THESE TRANSMITTERS

<u>Description</u>	<u>Model</u>
I/A Series Intelligent Temperature Transmitter	RTT20
<u>Output Signal and Communication Protocol</u> 4 to 20 mA only; no Remote Communication (a) 4 to 20 mA with HART Communication (b)	-I -T
<u>Input Configuration</u> Single Input Channel	1
<u>Package Configuration and Housing Material (Remote Mounted Sensor)</u> Surface or Pipe Mount, Aluminum Housing with 1/2 NPT Conduit Thread (Explosionproof) Surface or Pipe Mount, 316 ss Housing with 1/2 NPT Conduit Thread (Explosionproof)	S T
<u>Sensor Length</u> None (Not Applicable to Transmitters with Remote Mounted Sensors)	N
<u>Measurement Input Type (Software Selectable)</u> None - Specified Factory Default to Code Q Thermocouple, Type B, Platinum - 30% Rhodium vs. Platinum - 6% Rhodium Thermocouple, Type C, Tungsten - 5% Rhenium vs. Tungsten - 26% Rhenium Thermocouple, Type E, Nickel-Chromium vs. Copper-Nickel (Chromel-Constantan) Thermocouple, Type J, Iron vs. Copper-Nickel (Iron-Constantan) Thermocouple, Type K, Nickel-Chromium vs. Nickel-Aluminum (Chromel-Alumel) Thermocouple, Type L, Iron vs. Copper-Nickel Thermocouple, Type N, Nicrosil vs. Nisil (Nicrosil-Nisil) Thermocouple, Type R, Platinum - 13% Rhodium vs. Platinum Thermocouple, Type S, Platinum - 10% Rhodium vs. Platinum Thermocouple, Type T, Copper vs. Copper-Nickel (Copper-Constantan) Thermocouple, Type U, Copper vs. Copper-Low Nickel RTD, Platinum, DIN, 100 Ω, IEC 751 (ASTM-B Standard Accuracy) RTD, Platinum, DIN, 100 Ω, IEC 751 (ASTM-A High Accuracy) RTD, Platinum, 100 Ω, SAMA RTD, Nickel, 200 Ω, Foxboro NR 226/227 RTD, Nickel, 120 Ω, Minco RTD, Nickel, 100 Ω, DIN 43760 RTD, Copper, 10 Ω, Foxboro CR 228/229 Millivolt Input Ohms Input Dew Point Input Custom Input	X B C E J K L N R S T U Q A P D G I F M O W Z

SURFACE OR PIPE MOUNT TRANSMITTER - REMOTE SENSORS NOT PROVIDED WITH THESE TRANSMITTERS (Continued)

Description	Model
Electrical Safety (Also see "ELECTRICAL SAFETY SPECIFICATIONS" on page 11 for further details)	
CSA, Intrinsically Safe	CA
CSA, Explosionproof	CD
CSA, Division 2	CN
CENELEC (KEMA) Intrinsically Safe	EA
ATEX, flameproof	ED
FM, Intrinsically Safe and nonincendive	FA
FM, Explosionproof	FD
FM, Nonincendive	FN
CENELEC (KEMA) nonsparking/nonincendive	KN
IECEx flameproof, Ex D IIC	VV
Optional Selections	
Refer to "MODEL CODE" on page 20.	

- a. With Output Code "-I;" transmitter adjustment and output reconfiguration is possible only via an LCD Indicator/Configurator (Optional Selection "-L3") which is easily transportable between transmitters. Remote communication is not available.
- b. Remote configuration with HART Communicator, Foxboro PC-based Configurator, and/or Foxboro ABO991 software.

MODEL CODE

TRANSMITTER WITH INTEGRALLY MOUNTED BARE SENSOR

Description	Model
I/A Series Intelligent Temperature Transmitter	RTT20
Output Signal and Communication Protocol (a)	
4 to 20 mA only; no Remote Communication (a)	-I
4 to 20 mA with HART Communication (b)	-T
Input Configuration	
Single Input Channel	1
Package Configuration and Housing Material (Integrally Mounted Bare Sensor)	
Bare Sensor Mounted to Aluminum Housing; 1/2 NPT Conduit Threads (Explosionproof)	W
Bare Sensor Mounted to 316 ss Housing; 1/2 NPT Conduit Threads (Explosionproof)	Y
Sensor Length	
2 in (50 mm)	A
2.5 in (64 mm)	B
3 in (76 mm)	C
3.5 in (89 mm)	D
4 in (102 mm)	E
4.5 in (114 mm)	F
5 in (127 mm)	G
5.5 in (140 mm)	H
6 in (152 mm)	J
7 in (178 mm)	K
8 in (203 mm)	L
9 in (229 mm)	M
10 in (254 mm)	P
11 in (279 mm)	Q
12 in (305 mm)	R
18 in (457 mm)	S
24 in (610 mm)	T
30 in (762 mm)	U
36 in (914 mm)	V
Custom Length per Sales Order – 120 in (3 m) maximum	X
Measurement Input Type (Software Selectable)	
Thermocouple, Type E	E
Thermocouple, Type J	J
Thermocouple, Type K	K
Thermocouple, Type T	T
RTD, Platinum, DIN, 100 Ω, IEC 751 (ASTM-B Standard Accuracy)	Q
RTD, Platinum, DIN, 100 Ω, IEC 751 (ASTM-A High Accuracy)	A
RTD, Platinum, 100 Ω, SAMA	P

TRANSMITTER WITH INTEGRALLY MOUNTED BARE SENSOR (Continued)

<u>Description</u>	<u>Model</u>
<u>Electrical Safety (Also see "ELECTRICAL SAFETY SPECIFICATIONS" on page 11 for further details)</u>	
CSA, Intrinsically Safe	CA
CSA, Explosionproof	CD
CSA, Division 2	CN
CENELEC (KEMA) Intrinsically Safe	EA
ATEX, flameproof	ED
FM, Intrinsically Safe, ia	FA
FM, Explosionproof, d	FD
FM, Nonincendive, n	FN
CENELEC (KEMA) nonsparking/nonincendive	KN
IECEx flameproof, Ex d IIC	VV
<u>Optional Selections</u> Refer to "MODEL CODE" on page 20.	

- a. With Output Code "-I," transmitter adjustment and output reconfiguration is possible only via an LCD Indicator/Configurator (Optional Selection "-L3") which is easily transportable between transmitters. Remote communication is not available.
- b. Remote configuration with HART Communicator, Foxboro PC-based Configurator, and/or Foxboro ABO991 software.

MODEL CODE

TRANSMITTER WITH THERMOWELL MOUNT - INTEGRALLY MOUNTED SENSORS

Description	Model
I/A Series Intelligent Temperature Transmitter	RTT20
Output Signal and Communication Protocol (a)	
4 to 20 mA only; no Remote Communication (a)	-I
4 to 20 mA with HART Communication (b)	-T
Input Configuration	
Single Input Channel	1
Package Configuration and Housing Material (Integrally Mounted Sensor in Thermowell)	
Thermowell Mounted to Aluminum Housing; 1/2 NPT Conduit Threads (Explosionproof)	L
Thermowell Mounted to 316 ss Housing; 1/2 NPT Conduit Threads (Explosionproof)	M
Sensor Length	
2 in (50 mm)	A
2.5 in (64 mm)	B
3 in (76 mm)	C
3.5 in (89 mm)	D
4 in (102 mm)	E
4.5 in (114 mm)	F
5 in (127 mm)	G
5.5 in (140 mm)	H
6 in (152 mm)	J
7 in (178 mm)	K
8 in (203 mm)	L
9 in (229 mm)	M
10 in (254 mm)	P
11 in (279 mm)	Q
12 in (305 mm)	R
18 in (457 mm)	S
24 in (610 mm)	T
30 in (762 mm)	U
36 in (914 mm)	V
Custom Length per Sales Order – 120 in (3 m) maximum	X
Measurement Input Type (Software Selectable)	
Thermocouple, Type E	E
Thermocouple, Type J	J
Thermocouple, Type K	K
Thermocouple, Type T	T
RTD, Platinum, DIN, 100 Ω, IEC 751 (ASTM-B Standard Accuracy)	Q
RTD, Platinum, DIN, 100 Ω, IEC 751 (ASTM-A High Accuracy)	A
RTD, Platinum, 100 Ω, SAMA	P

TRANSMITTER WITH THERMOWELL MOUNT - INTEGRALLY MOUNTED SENSORS (Continued)

Description	Model
<p>Electrical Safety (Also see "ELECTRICAL SAFETY SPECIFICATIONS" on page 11 for further details) CSA, Intrinsically Safe CSA, Explosionproof (c) CSA, Division 2 CENELEC (KEMA) Intrinsically Safe ATEX, flameproof (c) FM, Intrinsically Safe, ia FM, Explosionproof, d (c) FM, Nonincendive, n CENELEC (KEMA) nonsparking/nonincendive IECEx flameproof, Ex d IIC (c)</p>	<p>CA CD CN EA ED FA FD FN KN VV</p>
<p>Optional Selections Refer to "MODEL CODE" on page 20.</p>	

- a. With Output Code "-I", transmitter adjustment and output reconfiguration is possible only via an LCD Indicator/Configurator (Optional Selection "-L3") which is easily transportable between transmitters. Remote communication is not available.
- b. Remote configuration with HART Communicator, Foxboro PC-based Configurator, and/or Foxboro ABO991 software.
- c. Must have Options -D2 with all explosionproof and flameproof approvals/certifications.

MODEL CODE

OPTIONAL SELECTION CODES

Option Description	Used with Package Configuration Code:							Option Code
	B	S	T	W	Y	L	M	
Custody Transfer Lock and Seal	-	Yes	Yes	Yes	Yes	Yes	Yes	-A1
PG 13.5 Conduit Thread (in lieu of 1/2 NPT) (a)	-	Yes	-	-	-	-	-	-A2
Metric Conduit Adapter (1/2 NPT to M20) (b)	-	Yes	Yes	-	-	-	-	-A3
Custom Database Configuration	Yes	Yes	Yes	Yes	Yes	Yes	Yes	-C2
DIN Rail Mounting Hardware (c)	Yes	-	-	-	-	-	-	-D1
Ship with Thermowell Attached (d)	-	-	-	-	-	Yes	Yes	-D2
Retrofit Kit - Adapts RTT20 to older Transmitters (e)	Yes	-	-	-	-	-	-	-D3
Thermowell, 3/4 NPT (Foxboro Std.); Supplied by User (f)	-	-	-	-	-	Yes	Yes	-D4
Stainless Steel Union Coupling	-	-	-	-	-	Yes	Yes	-H2
Delete Instruction Book	Yes	Yes	Yes	Yes	Yes	Yes	Yes	-K1
Three-Line LCD Indicator/Configurator	Yes	Yes	Yes	Yes	Yes	Yes	Yes	-L3
Mounting Set, Epoxy-Coated Steel	-	Yes	Yes	-	-	-	-	-M1
Mounting Set, 316 ss (g)	-	Yes	Yes	-	-	-	-	-M2
Inconel Sheath on RTDs or TCs	-	-	-	Yes	Yes	Yes	Yes	-S1
Dual Element Sensor (h)	-	-	-	Yes	Yes	Yes	Yes	-S2
4-Wire RTD Sensor	-	-	-	Yes	Yes	Yes	Yes	-S4

Examples: RTT20-D1SNJFA-A1C1C2M1; RTT20-T1WLPCA-A1S1S4; RTT20-D1LPEFD-C1C3D2S2

- a. PG 13.5 Conduit Thread not available with Option “-A3”
- b. Not available with Electrical Safety Codes CD or FD. Also not available with Option “-A2”
- c. Hardware only; DIN rail is provided by user.
- d. Required selection with Electrical Safety Codes CD or FD when Package Code L or M is used.
- e. The optional “-D3” retrofit kit provides an adapter plate and hardware to substitute an RTT20 into installations currently using an older type RTT10, 893, E93, and E94 Temperature Transmitter.
- f. Not available with Electrical Safety Codes CD or FD.
- g. For mounting transmitter to surface, or DN 50 or 2-in pipe.
- h. Two 2-wire RTDs in one sheath. Available with Output Codes “-D” and “-T” only, and with Sensor Input Types “Q” and “P”

NOTE

For further information relating to options, accessories, and services available with the RTT20 Temperature Transmitter, Refer to PSS 2A-1Z9 F

SUGGESTED RFQ SPECIFICATIONS

The manufacturer shall provide a microprocessor-based temperature transmitter with 4 to 20 mA or digital output which is linear to the measured temperature as follows:

Electronics:	Sealed Against Moisture
Sensors:	All Popular RTDs and Thermocouples
Self Calibration:	Automatic with No Prompt Required
Span Rangeability:	At Least 200:1
Enclosure:	Suitable for Remote or Integral Sensor Mounting (NEMA Type 4X and IP65)
Electrical Classification:	Intrinsically Safe or Explosionproof
Communications:	Must Not Interfere with Output
Configurators:	Integral and Remote Required
LCD Indicator:	Must Display Faults and Tag Number, and have Configuration Pushbuttons
Accuracy:	0.1°C for a 100 W Pt RTD at 0 to 100°C Span
Model Code:	Foxboro Model RTT20, or Equivalent

ALTERNATE SUGGESTED RFQ SPECIFICATIONS

The vendor shall furnish the following instrument for sensing temperature and transmitting a 4 to 20 mA or digital output signal. The instrument shall measure a temperature of ____ to ____°C using a thermocouple or RTD. Range is to be fully adjustable with span rangeability of at least 200:1 for each sensor. The transmitter shall be microprocessor-based with automatic self-calibration to virtually eliminate drift and ambient temperature errors. All diagnostic messages must be automatic and transmitted to a local display or remote configurators.

The transmitter housing should be suitable for integral or remote mounting of the sensor and shall be approved for use in hazardous locations (intrinsically safe and/or explosionproof). The basic transmitter shall be sealed and protected against moisture and other contaminants. The transmitter shall be a Foxboro I/A Series Temperature Transmitter, Model RTT20, or approved equivalent.

DIMENSIONS – NOMINAL

NOTE: For additional details, refer to Dimensional Print (DP 020-460).

mm
in

BASIC UNIT - PACKAGE CONFIGURATION CODE "B"

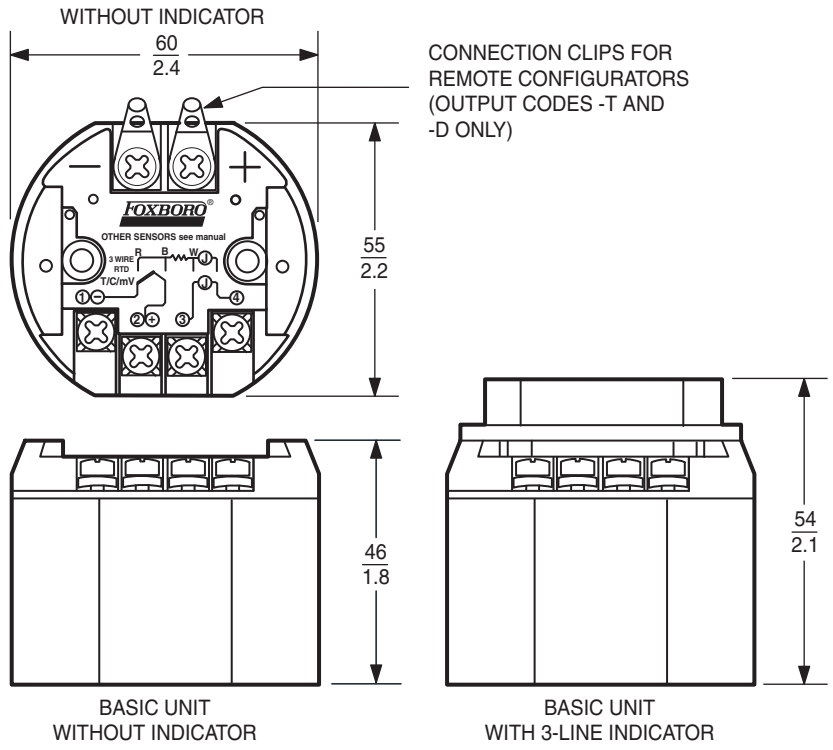

BASIC UNIT WITH DIN MOUNTING HARDWARE

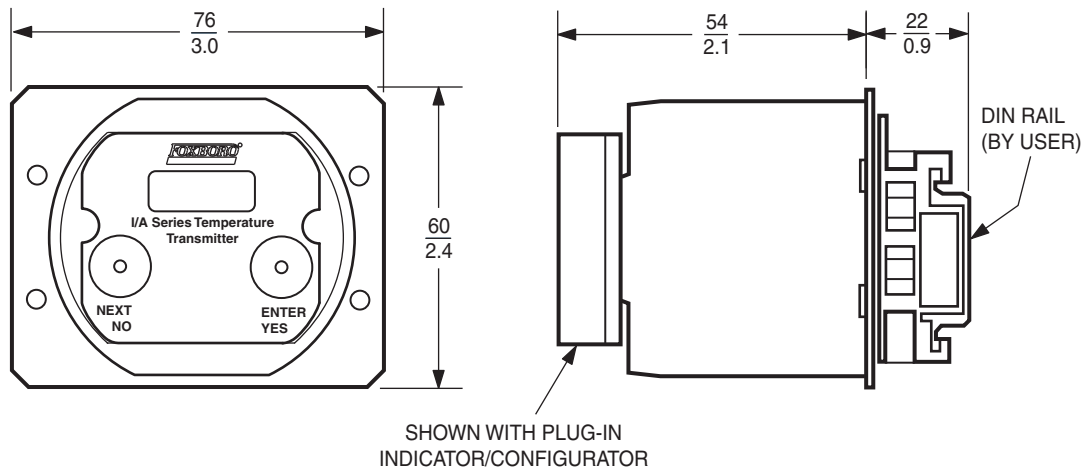

$\frac{\text{mm}}{\text{in}}$

SURFACE OR PIPE MOUNT TRANSMITTER WITH REMOTE SENSOR (PACKAGE CODE "S OR T")

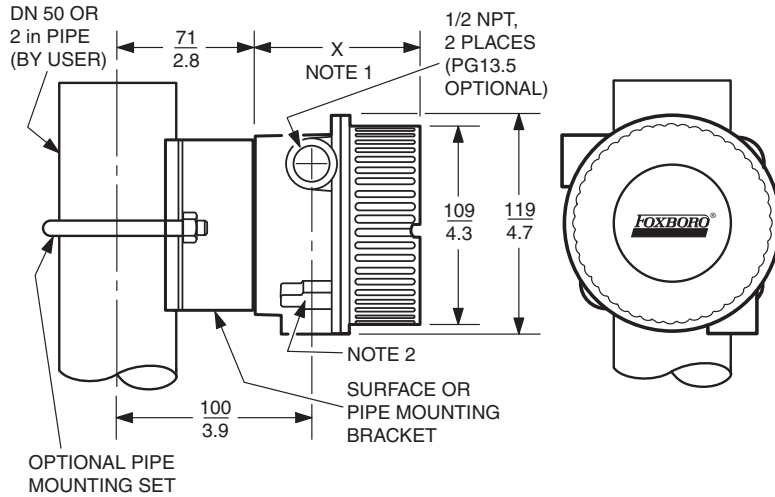

HOUSING MATERIAL	DIMENSION X (NOTE 1)	
	WITHOUT INDICATOR	WITH INDICATOR
316 ss	$\frac{87}{3.4}$	$\frac{99}{3.9}$
ALUMINUM	$\frac{87}{3.4}$	$\frac{112}{4.4}$

NOTES

1. ALLOW 51 mm (2 in) CLEARANCE FOR COVER REMOVAL.
2. EXTERNAL COVER LOCK AND GROUND SCREW LOCATION, WHEN APPLICABLE.

TRANSMITTER WITH INTEGRAL SENSOR (PACKAGE CODE "L, M, W, OR Y")

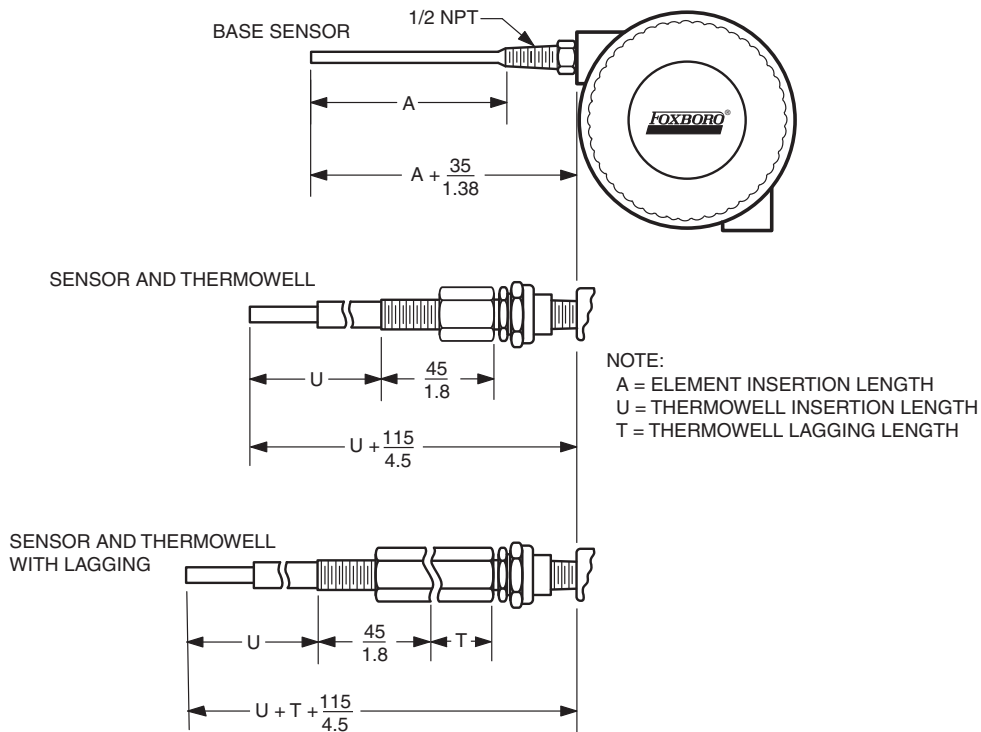

NOTE:

- A = ELEMENT INSERTION LENGTH
- U = THERMOWELL INSERTION LENGTH
- T = THERMOWELL LAGGING LENGTH

ORDERING INSTRUCTIONS

1. Model Number
2. Calibrated Range
3. Thermowell Part Number or Model, if required.
(See PSS 3-3C1 A for W-Series Wells, and
PSS 3-3D1 A for T-Series Wells)
4. Remote Configurator, if required
HART Communicator
Foxboro ABO991 Software (HART)
5. Tag Information

OTHER FOXBORO PRODUCTS

The Foxboro product lines offer a broad range of measurement and instrument products, including solutions for pressure, flow, analytical, temperature, positioning, controlling, and recording. For a list of these offerings, visit our web site at:

www.fielddevices.foxboro.com