

3-WAY

Features

- Brass body construction for general atmospheres; stainless steel for corrosive atmospheres
- Can be internally piloted, or externally piloted
- When externally piloted, loss of electrical power or auxiliary air exhausts air from the actuator and shifts process valve to its original position
- When internally piloted, loss of electric power returns the valve to its original position

Construction

Valve Parts in Contact with Fluids		
Body	Brass	316 Stainless Steel
End Plate	304 Stainless Steel	316 Stainless Steel
Seals and Discs	Low Temp NBR	
Core Tube	305 Stainless Steel	
Core Guide	POM	
Shading Coil	Copper	Silver

Electrical

Standard Coil and Class of Insulation	Watt Rating and Power Consumption				Spare Coil Part Number			
	DC Watts	AC			Explosionproof (EF)		Explosionproof (EV)	
		Watts	VA Holding	VA Inrush	AC	DC	AC	DC
F	11.6	10.1	25	50	272614	238714	274614	274714

Standard Voltages: 24, 120, 240, 480 volts AC, 60 Hz (or 110, 220 volts, AC, 50 Hz).
 6, 12, 24, 120, 240 volts DC. Must be specified when ordering.
 Other voltages are available when required.

Solenoid Enclosures

Standard: Explosionproof and Watertight, Types 3, 3S, 4, 4X, 6, 6P, 7, and 9.
 For *Optional Features*, consult factory.

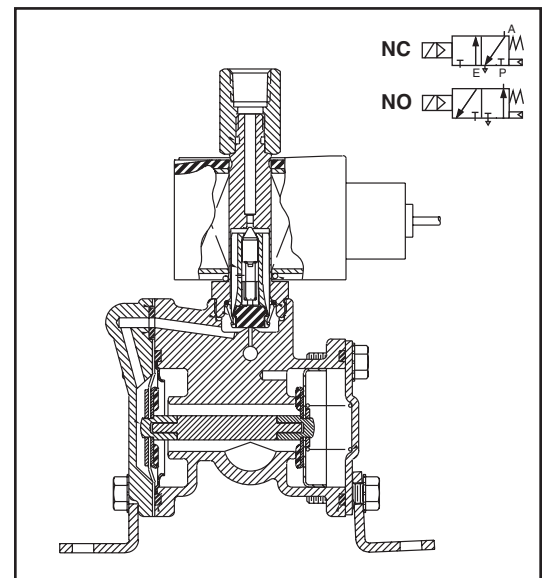
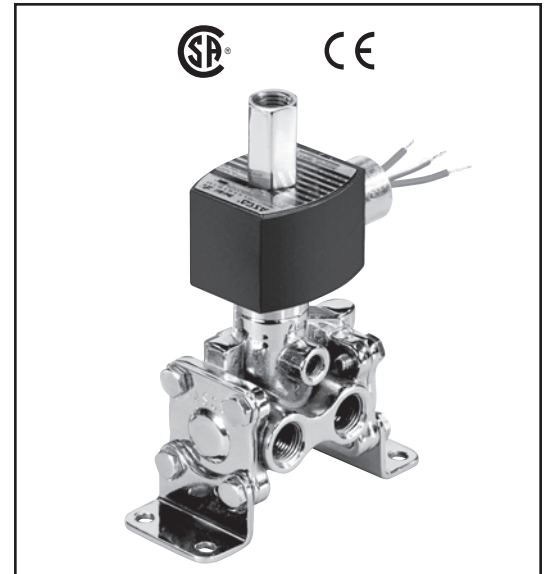

Nominal Ambient Temp. Ranges

AC: -40°F to 125°F (-40°C to 52°C)
 DC: -40°F to 104°F (-40°C to 40°C)

Approvals

CSA certified, UL listed solenoid.
 Meets applicable GE directives.

Installation

All valves may be mounted in any position.
 316 Stainless Steel mounting brackets available from ASCO. Add suffix "MB".

Specifications

Pipe Size (ins.)	Orifice Size (ins.)	CV Flow Factor	Min.	Max. Air Press. (psi)		Catalogue Number		Const. Ref.	Max. Fluid Temp. °F		Watt Rating/ Class of Coil Insulation	
				AC	DC	Brass Body	Stainless Steel		AC	DC	AC	DC
NORMALLY CLOSED (Closed when de-energized)												
1/4	5/16	1.5	①	150	120	EFX8316G001MF/15444	EVX8316G081MF/15444	1	180	120	10.1/F	11.6/F
3/8	5/16	1.6	①	150	120	EFX8316G002MF/15444	EVX8316G082MF/15444	1	180	120	10.1/F	11.6/F
3/8	5/8	4	②	150	120	EFX8316G003MF/15444	-	3	180	120	10.1/F	11.6/F
1/2	5/8	4	②	150	120	EFX8316G004MF/15444	EVX8316G084MF/15444	3	180	120	10.1/F	11.6/F

① At temperatures below 32°F: 15 psi minimum mainline operating pressure differential when valve selection gasket is in external position and proper auxiliary air pressure is applied. See graph below for pilot line pressure vs. mainline pressure.

Minimum 40 psi operating pressure differential when selection gasket is in the internal position.

② At temperatures below 32°F: 25 psi minimum mainline operating pressure differential when valve selection gasket is in external position and proper auxiliary air pressure is applied. See graph below for pilot line pressure vs. mainline pressure.

Minimum 50 psi operating pressure differential when selection gasket is in the internal position.

IMPORTANT: Internal mode Minimum Operating Pressure Differential must be maintained between the pressure and exhaust ports. Supply and exhaust piping must be full area and unrestricted. ASCO flow controls and similar components must be installed in the cylinder lines only.

Dimensions: inches (mm)

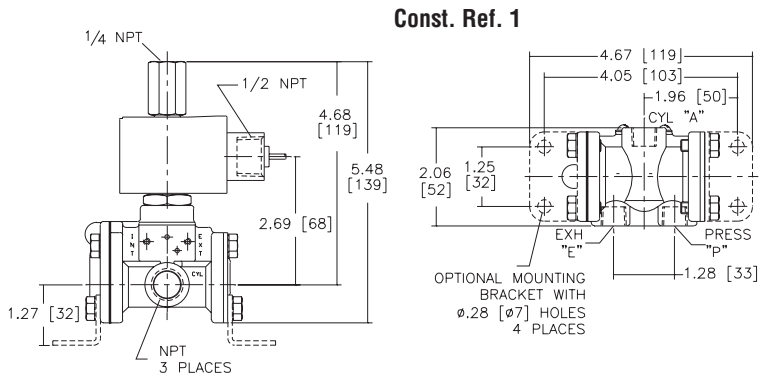
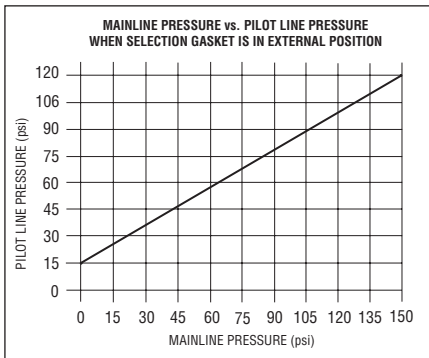

Const. Ref. 3

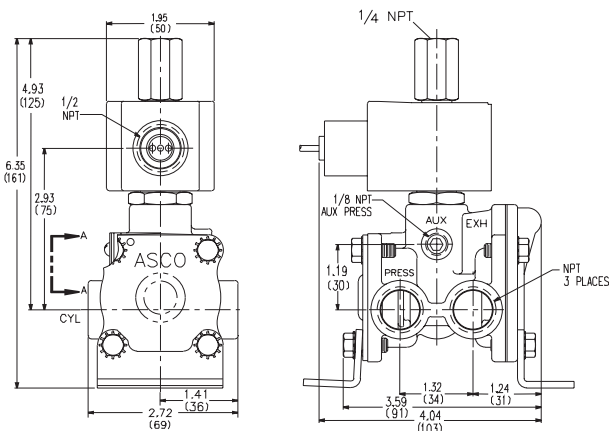

INTERNAL PILOTING MODE FLOW DIAGRAMS

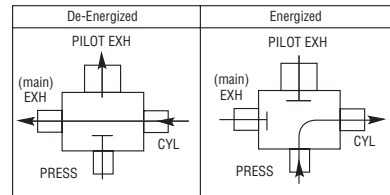

EXTERNAL PILOTING MODE FLOW DIAGRAMS

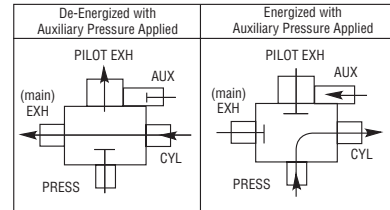

Features

- Designed for quick venting to 0 psi through the exhaust orifice
- Resilient seated poppets for tight shutoff
- Air is exhausted to quickly shift control valves
- Multi-industry applications
- Mountable in any position

Construction

Valve Parts in Contact with Fluids		
Body	Brass	304 Stainless Steel
Seals and Disc	NBR (PA upper disc)	
Diaphragm	CR	
Core Tube	305 Stainless Steel	
Core and Plugnut	430F Stainless Steel	
Core Springs	302 Stainless Steel and 17-7 PH Stainless Steel	
Shading Coil	Copper	Silver

Electrical

Standard Coil and Class of Insulation	Watt Rating and Power Consumption			Spare Coil Part Number
	AC			Explosionproof
	Watts	VA Holding	VA Inrush	AC
F	10.1	25	50	238614

Standard Voltages: 24, 120, 240, 480 volts AC, 60 Hz (or 110, 220 volts AC, 50 Hz).
 Must be specified when ordering.
 Other voltages available when required.

Solenoid Enclosures

Standard: Explosionproof and Watertight, Types 3, 3S, 4, 4X, 6, 6P, 7, and 9.
 For *Optional Features*, consult factory.

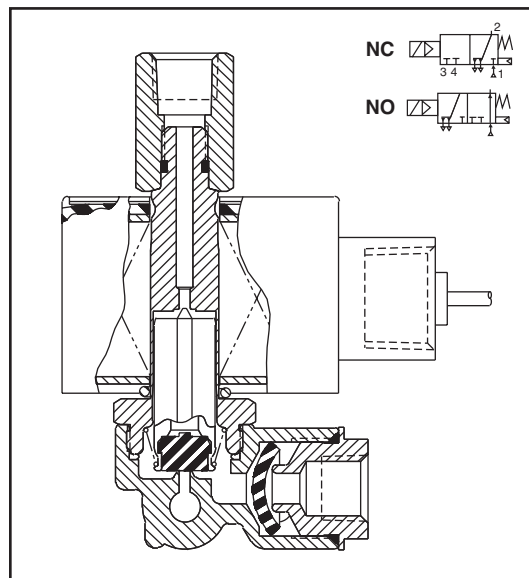
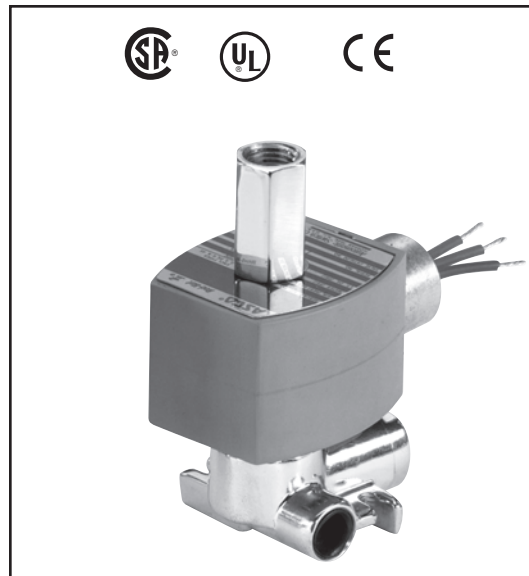

Nominal Ambient Temp. Ranges

AC: -40°F to 125°F (-40°C to 52°C)

Approvals

CSA certified, UL listed solenoid.
 Meets applicable CE directives.

Important

A Minimum Operating Pressure Differential must be maintained between the pressure and exhaust ports. Supply and exhaust piping must be full area, unrestricted. ASCO flow controls and other similar components must be installed in the cylinder lines only.

Specifications

Pipe Size (ins.)	Orifice Size (ins.)		Cv Flow Factor		Operating Pressure Differential (psi)		Max. Fluid Temp. °F	Brass Body		Stainless Steel Body		Watt Rating/ Class of Coil Insulation
	Press.	Exh.	Press.	Exh.	Min.	Air-Inert Gas		AC	Catalogue Number	Const. Ref.	Catalogue Number	
							Max. AC					AC
NORMALLY CLOSED (Closed when de-energized)												
1/4	3/32	1/4	.20	.73	5	150	180	EFX8317G035MF/18830	2	EFX8317G036MF/18830	4	10.1/F
NORMALLY OPEN (Open when de-energized)												
1/4	3/32	1/4	.15	.73	5	160	180	EFX8317G053MF/18830	2	-	-	10.1/F

Dimensions: inches (mm)

Const. Ref.		H	K	L	P	W
2	ins.	4.04	1.55	2.05	3.54	2.00
	mm	103	39	52	90	51
4	ins.	4.02	1.53	2.02	3.52	2.00
	mm	102	39	51	89	51

Const. Ref. 2, 4

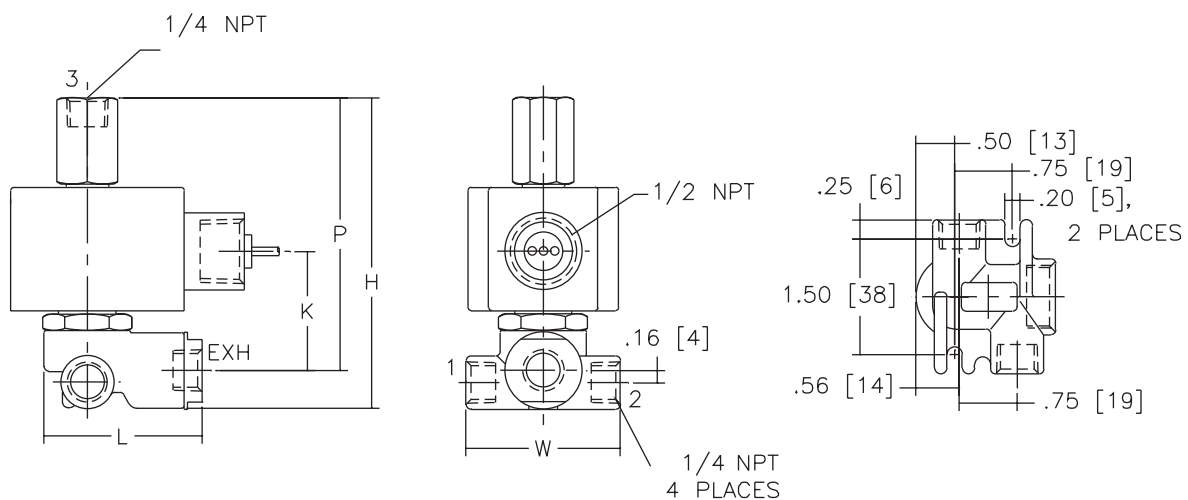

Features

- Moulded one-piece solenoid with highly efficient solenoid cartridge and special low wattage coil
- Designed for use in automation of plant control systems to provide:
 - PLC compatibility
 - Reduced battery drain
 - Reduced heat rise
 - Reduced wiring cost
- Wide selection includes 2/2 normally closed, 3/2 normally closed (including Quick Exhaust), 3/2 universal, and 4/2
- Air or inert gas only
- Lower-cost alternative to intrinsically safe valves in critical applications not requiring a safety barrier

Construction

Valve Parts in Contact with Fluids		
Body	Brass	Stainless Steel
Seals and Discs	NBR	
Sleeve	304L Stainless Steel	
Core and Plugnut	430F Stainless Steel	
Core Springs	302 Stainless Steel	
Pilot Seat Cartridge (Series 8316 & 8344 only)	POM	
Rider Rings	PTFE	
Spring Retainer	POM	

Electrical

Description	Wattage	Max. Ambient Temp.	T Code	Insulation Class	TPL
Standard Ambient Version	1.4W	140°F(60°C)	T6	F	-
High Ambient Version	1.8W	179°F(80°C)	T5	F	TPL #23033
Surge Suppression Version	1.7W	140°F(60°C)	T5	F	-
Surge Suppression High Ambient Version	2.0W	179°F(80°C)	T5	F	TPL #23033

Description	Wattage	Voltage (DC)	Min. Pull In (mA)	3way Drop Out (mA)	2way Drop Out (mA)	Coil resistance @68°F(20°C) (ohms)
Standard Ambient Version	1.4W	12V	83.5	13.9	3.2	102
		24V	42.0	7.0	1.6	410
		48V	21.4	3.6	0.8	1640
		120V	8.7	1.4	0.3	10000
High Ambient Version	1.8W	12V	94.3	15.7	3.6	80
		24V	47.9	8.0	1.8	320
		48V	24.0	4.0	0.9	1260
Surge Suppression Version	1.7W	12V	94.3	15.7	3.6	80
		24V	47.9	8.0	1.8	320
		48V	22.7	3.8	0.9	1470
Surge Suppression High Ambient Version	2.0W	12V	105.3	17.6	4.0	64
		24V	54.1	9.0	2.1	270
		48V	24.0	4.0	0.9	1260

24VDC Spare Coil P/N	Standard Ambient Temp. Version	High Ambient Temp. Version
General Purpose	238710-902-D*	238710-908-D*
Explosionproof	238714-902-D*	238714-905-D*
Explosionproof, Corrosion Resistant	274714-902-D*	274714-905-D*
Explosionproof, Surge Suppression	276006-006-D*	276006-106-D*
Explosionproof, Corrosion Resistant, Surge Suppression	276007-006-D*	276007-106-D*

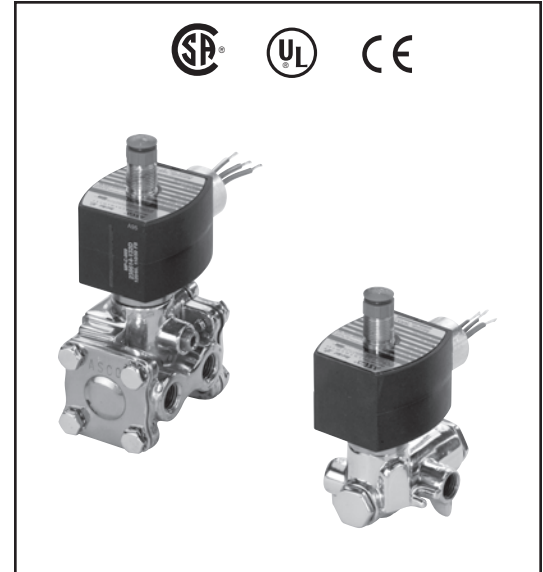

SPECIAL SERVICE VALVES

Nominal Ambient Temp. Ranges

Series	Body Material	Temperature Range
8316/15444	Brass & Stainless Steel	-40°F to 140°F (-40°C to 60°C)
8317		
8344/18897		
8223	Stainless Steel	-4°F to 140°F (-20°C to 60°C)
8316/17596	Stainless Steel	-59°F to 140°F (-50°C to 60°C)
8316/21104		

Approvals

8317/8223: UL listed General Purpose Valves (MP618), CSA certified (10381). Meets applicable CE directives.

83344/18897, 8316 as 15444, 17596 & 21104: UL listed solenoid (Hazardous Location Classified), CSA certified solenoid only, nonincendive for Class I, Division 2 UL E12264 for -40°F (-40°C). Meets applicable CE directives.

8317/8223 with EF/EV Prefix: UL listed (Hazardous Location Classified), Class I, Division 2 UL E25549. Certified CSA valve (13976). Meets applicable CE directives.

SIL 3 capable per IEC 61508 on 8316 const. Third party certification provided by EXIDA.

Solenoid Enclosures

Standard: Watertight, Types 1, 2, 3, 3S, 4, and 4X.

Optional: Explosionproof and Watertight, Types 3, 3S, 4, 4X, 6, 6P, 7, and 9. (To order, add prefix "EF" to catalogue number. For explosionproof with 316 Stainless Steel hub and trim, specify prefix "EV".) Surge suppression coils also available "MF" prefix.

For Optional Features, consult factory.

Specifications

Pipe Size (ins.)	Orifice Size (ins.)	Cv Flow Factor		Operating Pressure Differential (psi)		Max. Fluid and Ambient Temp. °F	Brass Body		Stainless Steel Body	
				Air-Inert Gas			Catalogue Number	Const. Ref.	Catalogue Number	Const. Ref.
		Pressure to Cylinder	Cylinder to Exhaust	Min.	Max.					
2/2 VALVES, NORMALLY CLOSED, with NBR Disc										
1/2	3/8	3.2		25	150	140	-	-	8223G310	20
3/2 VALVES, NORMALLY CLOSED (Closed when de-energized) with NBR Disc - SIL 3 Certified by Exida ⑨										
1/4	5/16	1.5	1.5	④	150	140	EFX8316G301MF/15444 ③	3	EVX8316G381MF/15444 ③	3
1/4	5/16	1.5	1.5	0 ⑦	110	140	-	-	EVX8316G381MB/17596 ⑧	3
1/4	5/16	1.5	1.5	15 ⑥	110	140	-	-	EVX8316G381MB/21104 ⑧	3
3/8	5/16	1.6	1.6	④	150	140	EFX8316G302MF/15444 ③	3	EVX8316G382MF/15444 ③	3
3/8	5/16	1.6	1.6	0 ⑦	110	140	-	-	EVX8316G382MB/17596 ⑧	3
3/8	5/16	1.6	1.6	15 ⑥	110	140	-	-	EVX8316G382MB/21104 ⑧	3
3/8	5/8	4	4	⑤	150	140	EFX8316G303MF/15444 ③	3A	-	-
1/2	5/8	4	4	⑤	150	140	EFX8316G304MF/15444 ③	3A	EVX8316G384MF/15444 ③	3A
3/2 VALVES, UNIVERSAL (Normally Closed or Normally Open) "Quick Exhaust" with NBR Diaphragm and NBR Disc										
1/4	②	.08	.73	5	150	140	8317G307 ①	6	8317G308 ①	7
4/2 VALVES, Brass Body with NBR Disc										
Pipe Size (ins.)	Orifice Size (ins.)	Cv Flow Factor		Operating Pressure Differential (psi)		Max. Fluid and Ambient Temp. °F	Single Solenoid		Dual Solenoid	
				Air-Inert Gas			Catalogue Number	Const. Ref.	Catalogue Number	Const. Ref.
		Pressure to Cylinder	Cylinder to Exhaust	Min.	Max.					
1/4	1/4	.80	1	30	150	140	EFX8344G370MF/18897 ①③	9	EFX8344G344MF/18897 ③	12
3/8	3/8	1.4	2.2	20	150	140	EFX8344G372MF/18897 ①③	11	EFX8344G380MF/18897 ③	10
1/2	3/8	1.4	2.2	20	150	140	EFX8344G374MF/18897 ①③	11	EFX8344G382MF/18897 ③	10
3/4	3/4	5.2	5.6	20	150	140	EFX8344G376MF/18897 ①③	13	-	-
1	3/4	5.2	5.6	20	150	140	EFX8344G378MF/18897 ①③	13	-	-

① There are two exhaust flows in the exhaust mode (pilot and main). The pilot exhaust must be connected to the main exhaust when the air or inert gas cannot be exhausted to atmosphere.
 ② For "Quick Exhaust" valves, pressure port is 1/16", exhaust port is 1/4".
 ③ **IMPORTANT:** A minimum operating pressure differential must be maintained between the pressure and exhaust ports. Supply and exhaust piping must be full area, unrestricted. ASCO flow controls and other similar components must be installed in the cylinder lines only.
 ④ At temperatures below 32°F: 15 psi minimum mainline operating pressure differential when valve selection gasket is in external position and proper auxiliary air pressure is applied. See graph on page 36 for auxiliary pressure vs. mainline pressure. Minimum 40 psi operating pressure differential when selection gasket is in the internal position.
 ⑤ At temperatures below 32°F: 25 psi minimum mainline operating pressure differential when valve selection gasket is in external position and proper auxiliary air pressure is applied. See graph on page 36 for auxiliary pressure vs. mainline pressure. Minimum 50 psi operating pressure differential when selection gasket is in the internal position.
 ⑥ **IMPORTANT:** Internal Pilot Construction: A minimum operating pressure differential must be maintained between the pressure and exhaust ports. Supply and exhaust piping must be full area, unrestricted. ASCO flow controls and other similar components must be installed in the cylinder lines only.
 ⑦ **IMPORTANT:** External Pilot Construction: Zero minimum operating pressure differential when the gasket is in the external position and proper auxiliary air pressure is applied. See graph on page 36 for pilot line pressure vs. mainline pressure.
 ⑧ At -59°F (-50°C), these constructions have a reduced life expectancy. Consult factory for details.
 ⑨ SIL 3 Certified by Exida, only valid when used as Normally Closed. Safety manual and FMEDA (Failure Modes Effects and Diagnostic Analysis) report available.
 ⑩ **IMPORTANT:** Supervisory and leakage current above the drop out current of 7mA for 24V DC will cause improper operation. Consult your local ASCO sales office for additional assistance.

SPECIAL SERVICE VALVES

Features

- Moulded one-piece solenoid with highly efficient solenoid cartridge and 0.55 W low wattage coil
- Standard ambient temperature of 149°F (65°C)
- Optional 176°F (80°C) high ambient temperature version
- Designed for use in automation of plant control systems to provide:
 - PLC and DCS compatibility for BUS network and traditional wiring
 - Reduced temperature rise
 - Increase battery life
 - Reduce wiring cost
 - Energy savings
- Wide selection includes 2/2 normally closed, 3/2 universal, 5/2, and 5/3

Construction

Valve Parts in Contact with Fluids		
Body	Brass	Stainless Steel
Seals and Discs	PUR, NBR, FKM, CR, as listed	
Sleeve	304L Stainless Steel	
Core and Plugnut	430F Stainless Steel	
Core Springs	302 Stainless Steel	
Rider Rings	PTFE	
Spring Retainer	POM	

Electrical

Description	Wattage	Max. Ambient Temp.	T Code	Insulation Class	Prefix
Standard Ambient Version	.55 W	149°F (65°C)	T6	F	-
High Ambient Version	.70 W	176°F (80°C)	T6	H	HT
Surge Suppression Version	.75 W	149°F (65°C)	T6	F	MF

Description	Wattage	Voltage (DC)	Min. Pull In (mA)	Drop Out (mA)	Coil Resistance @68°F (20°C) (ohms)
Standard Ambient Version	.55W	12V	34	1.8	255
		24V	17	0.89	1025
		48V	8.5	0.45	4080
		125V**	3.2	0.17	27,400
High Ambient Version	.70W	12V	37	1.9	206
		24V	19	0.98	830
		48V	9.7	0.52	3185
		125V**	3.7	0.2	21150
Surge Suppression Version	.75W	12V	41	2.2	165*
		24V	19	0.98	830*
		48V	9.7	0.52	3185*
		125V**	3.7	0.2	21150*

Note: * Surge suppression contains diode bridge. ** Not for battery applications

24VDC Spare Coil P/N	Standard Ambient Temp. Version	High Ambient Temp. Version
General Purpose	238910-906-D*	238910-906-D*
Explosionproof	238714-913-D*	238914-906-D*
Explosionproof, Corrosion Resistant	274714-909-D*	274914-906-D*
Explosionproof, Surge Suppression	276006-206-D*	Not Available
Explosionproof, Corrosion Resistant, Surge Suppression	276007-206-D*	Not Available

Note: For 12VDC, 48VDC and 125VDC coil PN consult factory

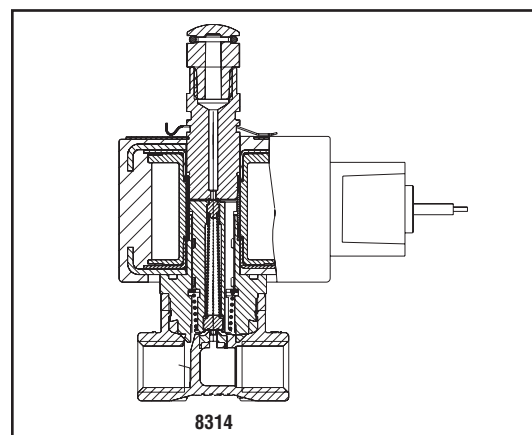

SPECIAL SERVICE VALVES

Solenoid Enclosures

Standard: Watertight, Types 1, 2, 3, 3S, 4, and 4X.

Optional: Explosionproof and Watertight, Types 3, 3S, 4, 4X, 6, 6P, 7, and 9.

(To order, add prefix "EF" to catalogue number. For explosionproof with 316 Stainless Steel hub and trim, specify prefix "EV".) Surge suppression coils also available "MF" prefix.

For Optional Features, consult factory.

Approvals

UL & CSA Approved for Class I Div. 1 Locations & Class I Div. 2 Nonincendive. UL Listed General Purpose Valves. Meets applicable CE directives.

Brass 8551 & 8553: UL listed solenoid (Hazardous Location Classified, E12264), CSA certified solenoid only (13976), nonincendive for Class I, Division 2, -40°F (-40°C). Meets applicable CE directives.

Stainless Steel 8551 with EF prefix: UL listed (Hazardous Location Qualified), Class I Division 2 UL E25549. Certified CSA valve (13976). Meets applicable CE directives.

SIL 3 capable per IEC 61508 on 8314, 8316, 8551, and 8553 const. Third party certification provided by EXIDA.