

March 2024

Type 252 Filter

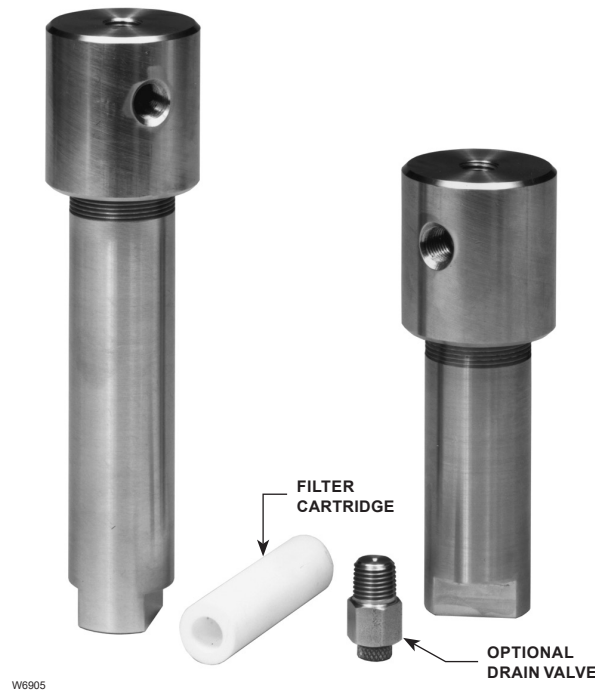

Figure 1. Type 252 Filters

Introduction

The Type 252 filter is designed to clean the supply gas or air before it enters pilots on pilot-operated regulators, pneumatic instruments or other devices that require clean mediums to operate properly. The Type 252 will prevent paint chips, dirt, pipe scale and some moisture from reaching the equipment that it is protecting.

Features

- **Excellent Filtration**—The polyethylene filter cartridge has a filtration capability of 20 microns.
- **Clean Pilot Supply**—Installing a filter in a pilot supply line will ensure cleaner air or gas supply to the pilot, preventing debris from clogging the pilot.
- **Drainage**—1/4 NPT tubing or pipe can be installed in place of the drain valve to provide a pipe away drain.
- **NACE Approved**—The filter complies with the recommendations of NACE MR0175.
- **Flow Capacity**—The aluminum body filter has a working pressure of up to 2150 psig / 148 bar and the stainless steel body has a working pressure of up to 2750 psig / 190 bar.

Type 252

Specifications

Inlet and Outlet Connections Size

1/4 NPT

Maximum Working Pressure^(1, 2)

Aluminum: 2150 psig / 148 bar

Stainless Steel: 2750 psig / 190 bar

Typical Flow Capabilities

See Figure 3

Typical Flow Coefficients

C_g: 20

C_v: 0.57

C_i: 35

Maximum Temperature Capabilities⁽¹⁾

-40 to 180°F / -40 to 82°C

Filter Rating

20 microns

Maximum Differential

100 psig / 6.9 bar

Construction Materials

Body Material: 316 Stainless Steel or Aluminum (A96061 T6)

Filter Cartridge: Polyethylene

O-ring: Nitrile (NBR)

Optional Drain Valve: 316 Stainless Steel

Approximate Weights

Standard Body:

Aluminum: 0.8 lbs / 0.4 kg

Stainless Steel: 2.3 lbs / 1 kg

Extended Body:

Aluminum: 1 lbs / 0.5 kg

Stainless Steel: 3 lbs / 1 kg

Dimensions

See Figure 4

1. The pressure/temperature limits in this bulletin and any applicable standard or code limitation should not be exceeded.
2. A pressure exceeding this value can cause failure of, or leakage from, pressure-containing components.

Construction

The Type 252 filter body is constructed of stainless steel or aluminum. A threaded connection securely joins the head and body and a Nitrile (NBR) O-ring assures a tight seal. Upper and lower filter seats securely hold the polyethylene filter cartridge in place.

The optional stainless steel drain valve consists of a poppet, spring and stainless steel body, with a vent hole to bleed excess liquid. The knurled cap is permanently assembled to the valve for safety.

Installation

Thoroughly clean and blow all pipelines to remove pipe scale and other foreign matter which accelerate the clogging of the filter.

When installing the filter, follow established piping practices. Apply a good grade of pipe compound to the external pipeline threads. Install the filter in the line with the flow as indicated by the in and out markings on the filter head.

NACE Standard MR0175 Compliance

Optional materials are available for applications handling sour gases. These constructions comply with the recommendations of NACE International sour service standards.

The manufacturing processes and materials used by Emerson assure that all products specified for sour gas service comply with the chemical, physical and metallurgical requirements of NACE MR0175 and/or NACE MR0103. Customers have the responsibility to specify correct materials. Environmental limitations may apply and shall be determined by the user.

Incoming raw materials are tightly controlled by specifications which cover chemical, composition, forming, hardness, heat treatment and finish. In addition, the subsequent machining, welding and heat treatment of the materials as they are processed into finished parts are strictly controlled.

Capacity Information

The typical flow capacities shown in Figure 3 are calculated based on the flow (SCFH) of natural gas at 14.7 psig and 60°F. To determine equivalent capacities for air, propane, butane or nitrogen, multiply the listed capacity by the following appropriate conversion factor: 0.775 for air, 0.628 for propane, 0.548 for butane or 0.789 for nitrogen. For gases of other specific gravities, multiply the given appropriate specific gravity. If capacity is desired in normal cubic meters per hour (Nm³/h) at 0°C and 1.01325 bar, multiply SCFH by 0.0268.

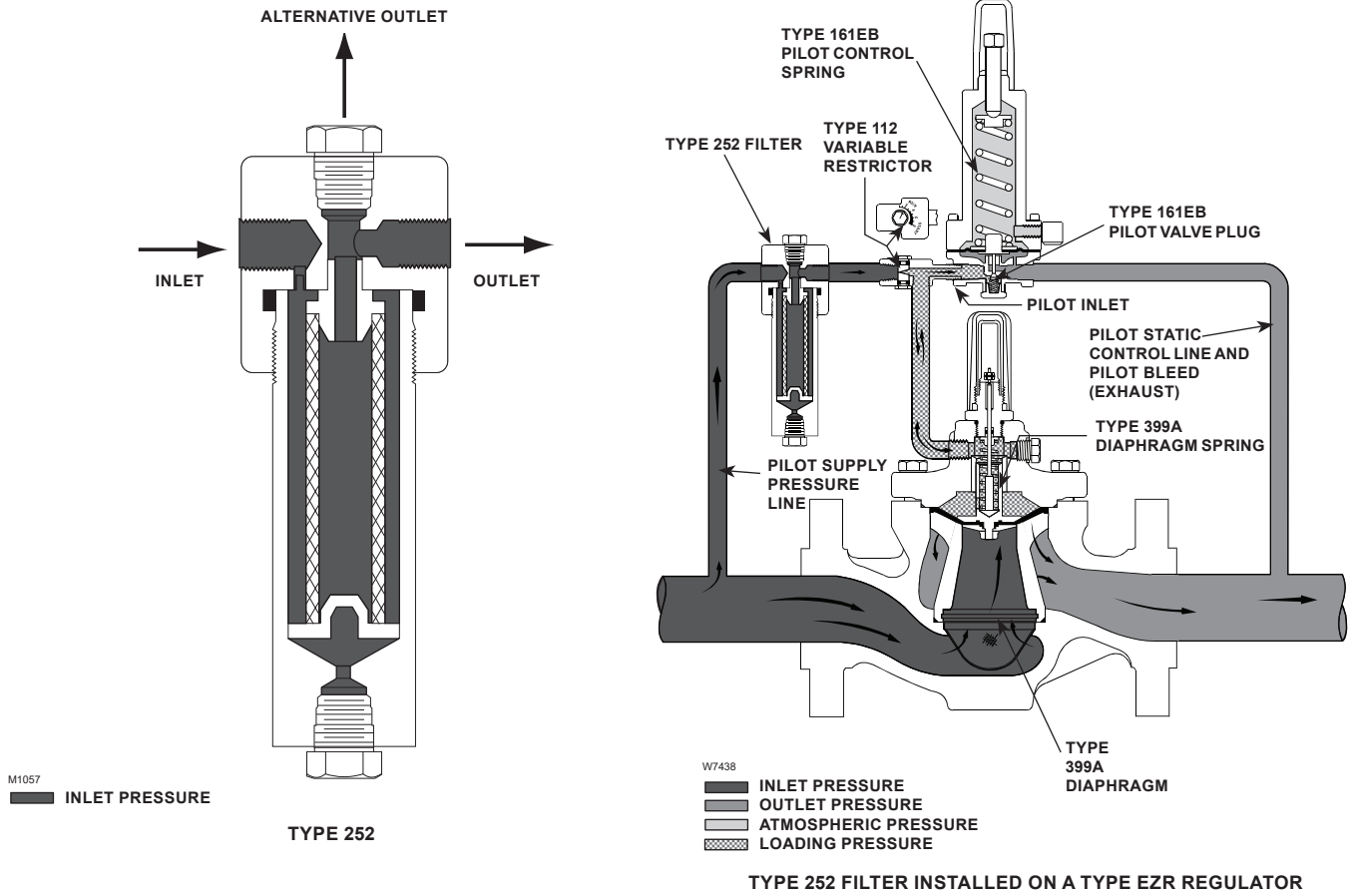

Figure 2. Operational Schematics

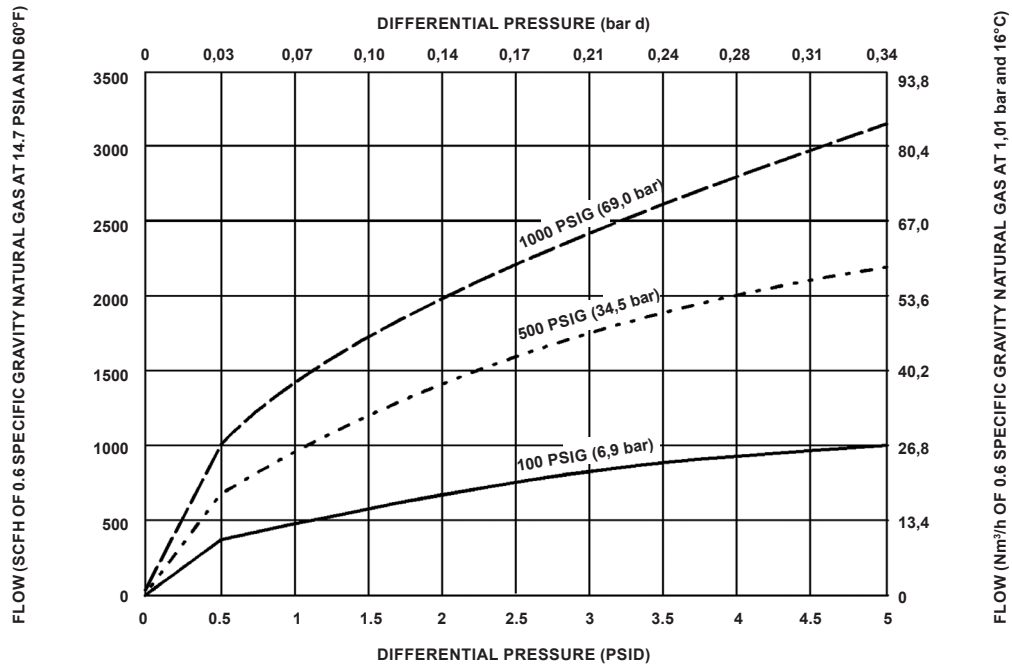
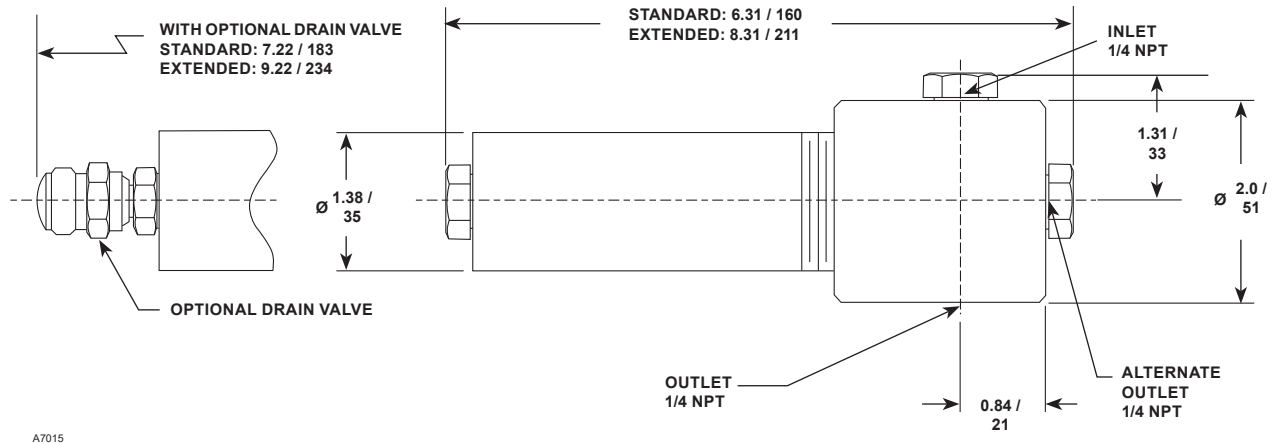

Figure 3. Typical Flow Capabilities

Type 252



A7015

Figure 4. Dimensions

IN. /
mm

For example, to convert the capacity information from natural gas to air for an inlet pressure of 3000 SCFH / 80.4 Nm³/h, use the following formula.

$$\text{Air SCFH} = 0.775 \times 3000 = 2325$$

Therefore, the equivalent capacity for air at 14.7 psia and 60°F would be 2325 SCFH / 62.3 Nm³/h.

Ordering Information

When ordering, specify standard or extended filter body, with or without the optional drain valve and the desired construction material.

✉ Webadmin.Regulators@emerson.com

🔍 Fisher.com

📘 Facebook.com/EmersonAutomationSolutions

🌐 LinkedIn.com/company/emerson-automation-solutions

🐦 Twitter.com/emr_automation

Emerson

Americas

McKinney, Texas 75070 USA
T +1 800 558 5853
+1 972 548 3574

Europe

Bologna 40013, Italy
T +39 051 419 0611

Asia Pacific

Singapore 128461, Singapore
T +65 6777 8211

Middle East and Africa

Dubai, United Arab Emirates
T +971 4 811 8100

D102466X012 © 1997, 2024 Emerson Process Management Regulator Technologies, Inc. All rights reserved. 03/24.

The Emerson logo is a trademark and service mark of Emerson Electric Co. All other marks are the property of their prospective owners. Fisher™ is a mark owned by Fisher Controls International LLC, a business of Emerson Automation Solutions.

The contents of this publication are presented for informational purposes only, and while every effort has been made to ensure their accuracy, they are not to be construed as warranties or guarantees, express or implied, regarding the products or services described herein or their use or applicability. All sales are governed by our terms and conditions, which are available upon request. We reserve the right to modify or improve the designs or specifications of such products at any time without notice.

Emerson Process Management Regulator Technologies, Inc. does not assume responsibility for the selection, use or maintenance of any product. Responsibility for proper selection, use and maintenance of any Emerson Process Management Regulator Technologies, Inc. product remains solely with the purchaser.

