

Models
64A
65A



Model 64A



Model 65A

Features

- The Models 64A and 65A Service Regulators are precision units used in instrumentation and general purpose applications.
- An Aspirator Tube compensates downstream pressure droop under flow conditions.
- A large Control Diaphragm area provides increased sensitivity.
- A full Flow Gage Port provides convenient pressure gage mounting.
- The Model 65 Standard 5-Micron Filter prevents particles from entering the output airstream.
- The Model 65 Filter Dripwell contains a Petcock Valve to easily drain trapped liquids.

Operating Principles

When you adjust the Range Screw to a specific setpoint, the Range Spring exerts a downward force against the top of the Control Diaphragm. This downward force opens the Supply Valve. Output pressure flows through the Outlet Port and the Aspirator Tube to the Control Chamber where it creates an upward force on the bottom of the Control Diaphragm.

When the setpoint is reached, the force of the Range Spring that acts on the top of the Control Diaphragm balances with the force of output pressure that acts on the bottom of the Control Diaphragm and closes the Supply Valve.

When the output pressure increases above the set point, the Diaphragm Assembly moves upward to close the Supply Valve and open the Exhaust Valve. Output pressure flows through the Exhaust Valve and out of the Vent on the side of the unit until it reaches the setpoint. For more information, see cross sectional diagram.

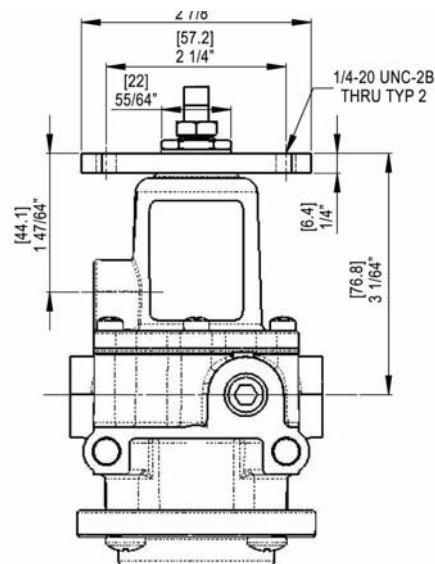

"P" OPTION (PANEL MOUNT)

Model 64A

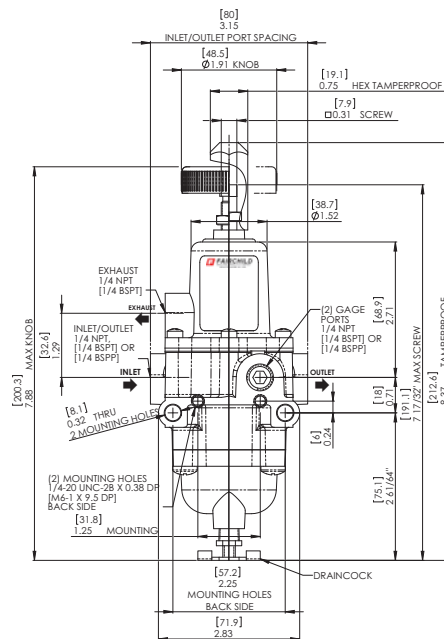

Model 65A

Technical Information

Flow Characteristics
Fairchild Model 65952

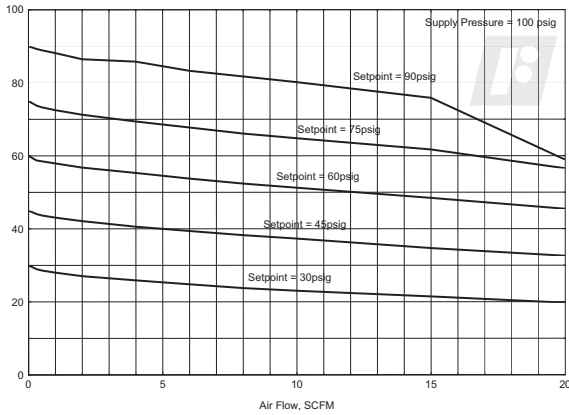

Specifications

Supply Pressure

300 psig, [21.0 BAR], (2100 kPa) Maximum

Flow Capacity (SCFM)

22 (37.4 m³/HR) @ 100 psig, [7 BAR], (700 kPa) supply and 20 psig, [1.5 BAR], (150 kPa) setpoint

Exhaust Capacity (SCFM)

1 (1.72 m³/HR) where downstream pressure is 5 psig, [.35 BAR], (35 kPa) above 20 psig, [1.5 BAR], (150 kPa) setpoint

Supply Pressure Effect

Less than 0.1 psig, [.007 BAR, (1.7 kPa) for 25 psig, [1.7 BAR], (170 kPa) change in supply pressure

Sensitivity

1" (2.50 cm) Water Column

Temperature Range

-40° F to + 180° F, (-40° C to + 82° C)

Materials of Construction

Body and Housing Aluminum

Trim Zinc Plated Steel, Brass

Elastomers Nitrile on Dacron

Catalog Information

Catalog Number



Models

64 48

65 59

Pressure Range

psig	[BAR]	(kPa)	
0.5-30	[0.03-2]	(3-200)...	3
1-60	[0.10-4]	(10-400)...	4
2-120	[0.15-8]	(15-800)...	5

Pipe Size

1/4" NPT 2

Port Thread

NPT N
 BSPP ¹ H
 BSPT ¹ U

Options

Actuator Knob Adjust K
 Screw S
 Tamper Proof T

Other Options

Quick Bleed C
 2" Gauge NPT Only ¹ G
 Screen in Exhaust M
 Stainless Steel Trim S
 Panel Mount P

¹BSPP Threads in Inlet & Outlet Ports Only. Others BSPT.

Installation

For installation instructions, refer to the *Fairchild Model 64A, 65A Pneumatic Service Regulator Installation, Operation and Maintenance Instructions, IS-1064A65A.*