

DP17 and DP17G Pressure Reducing Valves Pilot Operated with SG Iron Bodies

Description

The DP17 is an SG iron pilot operated pressure reducing valve suitable for steam or compressed air.

The DP17G is an SG iron pilot operated pressure reducing valve suitable for compressed air and industrial gases. **Note: it is not suitable for oxygen services.**

Sizes and pipe connections

DN15LC (not available for type DP17G), 15, 20, 25, 32, 40 and 50
Screwed BSP (BS 21 parallel) or API (DN15 to 25 only)

Flanges to DN15 - 50 BS 4504 PN16 and PN25
DN25 - 50 BS 10 Table H and ANSI 300

Also available are DN15 - 50 JIS 10/16 and ANSI 150
DN15 - 20 BS 10 Table F
DN15 - ANSI 300

Limiting conditions

Body design conditions	PN25
Maximum design temperature	DP17 232°C
	DP17G 120°C

Designed for a maximum cold hydraulic test pressure of 38 bar g

Operating range

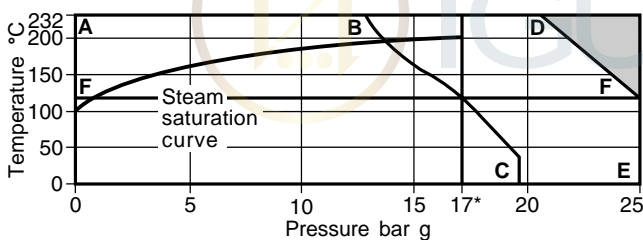

This product must not be used in this region.

* PMO Maximum steam pressure recommended 17 bar g.

A-D-E Screwed and flanged BS 4504 PN25, ANSI 300, and BS 10 Table H.

A-B-C Flanged ANSI 150.

F - F The DP17G is limited to 120°C.

Three colour coded pressure adjustment springs are available for the following downstream pressure ranges:

Yellow 0.2 bar g to 3 bar g

Blue 2.5 bar g to 7 bar g

Red 6.0 bar g to 17 bar g

Dimensions / weights (approximate) in mm and kg

Size	Screwed							B	D	E	F	Weight	
	A	BS 10 H A1	PN16/25 A1	ANSI 300 A1	BS 10 F A1	ANSI 150 A1	JIS 10/16 A1					Screwed	Flanged
DN15LC	160	-	130	126.6	117	120.2	122	185	364	234	130	12.0	12.8
DN15	160	-	130	126.6	117	120.2	122	185	364	234	130	12.0	12.8
DN20	160	-	150	-	133	139.4	142	185	364	234	130	12.0	13.7
DN25	180	160	160	160.0	-	160.0	152	207	388	240	148	13.0	16.0
DN32	-	180	180	180.0	-	176.0	176	207	388	240	148	-	17.0
DN40	-	200	200	200.0	-	199.0	196	255	433	255	178	-	29.0
DN50	-	230	230	230.0	-	228.0	222	255	433	255	178	-	31.5

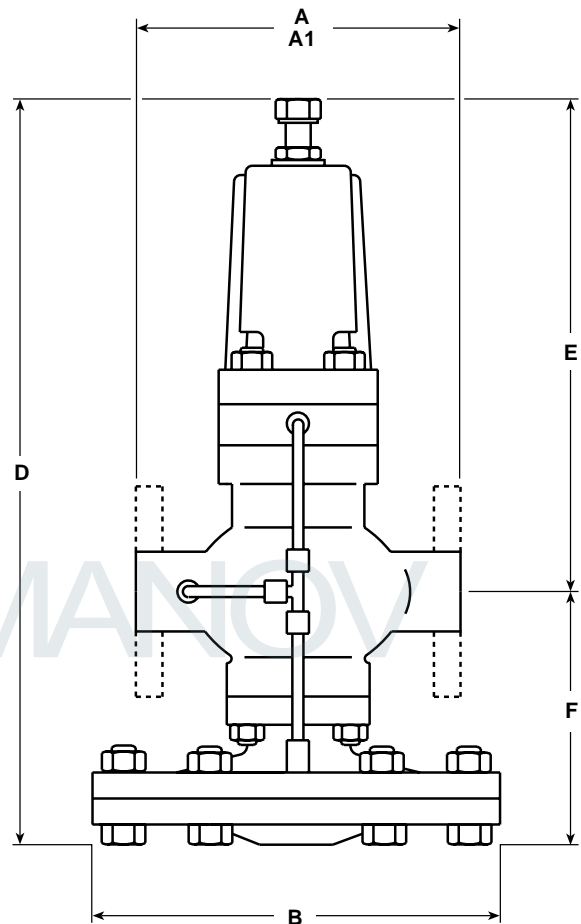

Capacities

See TI-P006-03 for steam sizing and TI-P007-02 for compressed air. A low capacity version of the DN15 is available Type DN15LC. The K_V maximum values shown below are full capacities and should be used for safety valve sizing purposes only.

DN15LC	DN15	DN20	DN25	DN32	DN40	DN50
1.0	2.8	5.5	8.1	12.0	17.0	28.0

For conversion C_V (UK) = $K_V \times 0.97$ C_V (US) = $K_V \times 1.17$

Note: Where the internal downstream pressure sensing pipe is used the valve capacity will be reduced.

Materials

No. Part	Material		
1	Adjustment screw	Steel	BS 3692 Gr. 8.8
2	Adjustment lock-nut	Steel	BS 3692 Gr. 8.8
3	Washer	Stainless steel	BS 1449 304 S 16
4	Spring housing	SG iron	DIN 1693 GGG 40
5	Top spring plate	Brass	BS 2872 CZ 122
6	Pressure adjustment spring	Stainless steel	BS 2056 302 S 25
7	Bottom spring plate	Brass	BS 2872 CZ 122
8	Spring housing securing studs and nuts	Steel M10 x 50 mm	BS 4439 Gr. 8.8 BS 3692 Gr. 8
9	Pilot diaphragms	Phosphor bronze	BS 2870 PB 102 1980
10	Pilot valve housing	SG iron	DIN 1693 GGG 40.3
11	Pilot valve plunger	Stainless steel	BS 970 431 S 29
12	Spring housing cover	Stainless steel	BS 1449 304 S 12 2A
	Pilot valve and seat unit	Stainless steel/PTFE	BS 970 431 S 29
* 13	Filter element (not shown)	Brass	
14	Internal strainer	Stainless steel	ASTM A240 TP 304
15	Body gasket	Stainless steel reinforced exfoliated graphite	
16	Main valve return spring	Stainless steel	BS 2056 302 S 25
* 17	Main valve	Stainless steel	BS 970 431 S 29
18	Main valve seat	Stainless steel	BS 970 431 S 29
19	Pressure sensing pipe	Copper	BS 2871 C 106 ½H
20	Main valve body	SG iron	DIN 1693 GGG 40.3
	Main body securing studs and nuts	Steel M10 x 25 mm	BS 4439 Gr. 8.8 BS 3692 Gr. 8
22	Main diaphragm chamber	SG iron	DIN 1693 GGG 40.3
	Main diaphragm securing bolts and nuts	Steel M12 x 50 mm	BS 3692 Gr. 8.8 BS 3692 Gr. 8
24	Main diaphragms	Phosphor bronze	BS 2870 PB 102 1980
25	Main diaphragm plate	Brass	BS 2872 CZ 122
26	Push rod	Stainless steel	BS 970 431 S 29
27	Pipe assembly	Brass and copper	
28	Plug ¼" BSP	Steel	
29	Pressure pipe union	Brass	
30	Lock-nut	Steel	BS 3692 Gr. 8

* Stainless steel/nitrile with version DP17G.

How to order

Example: 1 off DN32 Spirax Sarco DP17 pressure reducing valve flanged BS 4504 PN25.

Spare parts See TI-P100-03

Installation

The valve should be installed in a horizontal pipeline with the direction of flow as indicated by the arrow on the valve body. Full Installation and Maintenance Instructions are supplied with the product.

