

General Specifications

Model DY Vortex Flowmeter Model DYA Vortex Flow Converter

digitalYEWFLO

GS 01F06A00-01EN



Model DY Vortex Flowmeter
Integral Type



Model DYA
Vortex Flow Converter



Model DY Vortex Flowmeter
Remote Type Detector



Model DY/R1, DY/R2
Reduced Bore Type
*Integral Type/Remote Type

Based on the field proven technology

By the unique **SSP (Spectral signal processing)*** technology, digitalYEWFLO provides high accuracy and stability, even in harsh process conditions. Combined with high reliability and robust design, it delivers improvements in plant efficiency and reduced operating costs.

digitalYEWFLO Multi-Variable Type (Option: /MV) built-in temperature sensor, so that temperature measurement and Mass Flow calculation is available.

digitalYEWFLO Reduced Bore Type (Option: /R1, /R2) integrated and casting construction with concentric reduced bore piping.

It benefits piping cost reduction and lower flow range.

* SSP is YOKOGAWA's original technology for digital signal processing.

■ FEATURES

- **SSP (Spectral Signal Processing)** technology: SSP is built into the powerful electronics of digitalYEWFLO. SSP analyses the fluid conditions inside digitalYEWFLO and uses the data to automatically select the optimum adjustment for the application, **providing features never before realized in a vortex flowmeter.** SSP accurately senses vortices in the low flow range, providing outstanding flow stability.
- **Self-diagnostics:** The application condition, such as high vibration of the piping and pulsating flow, is predicted and indicated.
- **High Accuracy:**
±0.75% of Reading (Liquid)
±0.5% of Reading: Typical Accuracy/ Non-Guaranteed
±1% of Reading (Gas, Steam)
- **Wide Process Temperature Range:**
High temperature version up to +450°C
Cryogenic version minimum -196°C
- **Simple Parameter settings:** Frequently-used selections grouped together in a quick-access format decreases commissioning time.
- **Clear, Concise Indicator:** Simultaneous flow rate or temperature (Option: /MV) and total flow rate along with process diagnosis conveniently displayed.
- **Dual output for Analog / Pulse:** Simultaneous output for flow rate or temperature (Option: /MV) and pulse.
- **Alarm output, Status output (Flow switch)** An alarm signal output, in case alarm occurs.
- **No moving parts stainless steel detector:** High durable and safety.
- **Signal cable length is up to 30m.**
- **Explosion proof construction, TIIS / FM / ATEX / CSA / SAA (Intrinsically safe), IECEx.**

Contents

FEATURES	P. 1
STANDARD SPECIFICATIONS	P. 2
MODEL AND SUFFIX CODES	P. 5
OPTION SPECIFICATIONS	P. 8
OPTION MULTI-VARIABLE (BUILD-IN TEMPERATURE SENSOR) TYPE (/MV)	P.10
OPTION REDUCED BORE TYPE (/R1, /R2)	P.11
SIZING	P.11
DETAILED ACCURACY	P.13
OPTION SPECIFICATIONS (FOR EXPLOSION PROTECTED TYPE)	P.19
REMARKS ON INSTALLATION	P.21
EXTERNAL DIMENSIONS	P.25
OPERATING INSTRUCTIONS	P.44

[MULTI-VARIABLE TYPE] (OPTION: /MV)

digitalYEWFLOW build-in temperature sensor (Pt1000) in the vortex shedder bar.

Temperature measurement and Mass Flow Calculation by temperature is available.

(Refer to P.10)

- High Process Temperature Version Multi-Variable Type (Option: combination of /HT and /MV)

The combination of /HT and /MV is available up to 400 °C (330 °C for Saturated Steam).

- digitalYEWFLOW build-in steam table (IAPWS-IF97), and Mass measurement of saturated steam and superheated steam (Mass Flow Calculation)
- Accuracy of digitalYEWFLOW Multi-Variable Type is $\pm 0.5\%$ of rate for temperature measurement, $\pm 2\%$ of rate for Mass Flow Calculation (saturated steam).

[REDUCED BORE TYPE] (OPTION: /R1, /R2)

Integrated and casting construction with concentric reduced bore piping makes ;

- Reduction of the piping cost and improving the safety of the work site
- Replace work and cost reduction: the same face-to-face dimension with standard type.
- Stability and expansion of the low flow rate

■ STANDARD SPECIFICATIONS

- Communication function includes FOUNDATION fieldbus, BRAIN and HART protocol.
Refer to GS 01F06F01-01EN for Fieldbus communication type marked with "◇".

Performance Specifications

Fluid to be Measured:

Liquid, Gas, Steam (Avoid multiphase flow and sticky fluids)

Measuring Flow Rates:

Refer to Table 6

Accuracy: $\pm 0.75\%$ of Reading (Liquid)
 $\pm 1\%$ of Reading (Gas, Steam)
Refer to P.13.

/MV: Refer to P.14

Repeatability: $\pm 0.2\%$ of Reading

Calibration:

This flowmeter is factory-calibrated using a water flow.

Temperature and flow calibration by water flow when Multi-Variable Type is selected.

Normal Operating Condition

Process Temperature Range:

–29 to +250 °C (Standard)
–196 to +100 °C (Cryogenic Version: Option)
–29 to +450 °C (High Process Temperature Version: Option)

–29 to +400 °C (High Process Temperature Version Multi-Variable Type: Option)

When Multi-Variable Type is selected, refer to P.10.

Refer to Figure 1 for integral type.

Process Pressure Limit:

–0.1MPa (–1 kg/cm²) to flange rating.

Ambient Temperature Range:

–29 to +85 °C (Remote Type detector)
–40 to +85 °C (Remote Type converter)
–29 to +85 °C (Integral Type, refer to Figure 1)
–29 to +80 °C (Integral Type with Indicator, refer to Figure 1)
–30 to +80 °C (Remote Type converter with Indicator)

Ambient Humidity: 5 to 100% RH (at 40 °C)
(No Condensation)

Power Supply Voltage (◇): 10.5 to 42 V DC
10.5 to 30 V DC (Lightning Protector: option)
(Refer to Figure 2 ; Relationship Between Power Supply Voltage and Load Resistance)

Mechanical Specifications

Material (Standard Type):

Refer to Table.1

Wetted Parts:

Body*¹; Stainless steel JIS SCS14A, ASTM CF8M

*1 Flange materials for DY250 to DY400 are JIS SUS F304

Shedder Bar; Duplex stainless steel

Size 15mm ASTM S31803

Size 25mm to 400mm EN 1.4517

Gasket: JIS SUS316 stainless steel with polytetrafluoroethylene (Teflon) coating.

Non-Wetted Parts:

Housing (Case, Cover):

Aluminum alloy JIS ADC12

Name Plate: Stainless steel JIS SUS304

DYA Mounting Bracket for 2B pipe:

Carbon steel sheet JIS SPCC, JIS SECC

Coating Color:

Housing:

Polyurethane corrosion-resistant coating

Deep sea moss green (Munsell 0.6GY 3.1/2.0)

DYA Mounting Bracket for 2B pipe:

Polyurethane corrosion-resistant coating

Frosty white (Munsell 2.5Y 8.4/1.2)

Degree of Protection:

IP66/IP67 (IEC 60529), Type 4X (NEMA 250)

Type of Protection:

Refer to item "OPTION SPECIFICATIONS"

Electrical Connection:

JIS G1/2 female, ANSI 1/2 NPT female, ISO M20 × 1.5 female

Signal Cable:

Model DYC signal cable, used for remote detector and converter.

Signal cable length is up to 30 m.

Outer Sheath Material: Heat resisting polyethylene

Durable Temperature: –40 to +150 °C

Weight:

Refer to item "External Dimensions".

Mounting:

Integral type and Remote type detector:
 Flange mounting or wafer mounting by flange adjacent to the pipeline.
 Remote type converter: 2 inch pipe mounting.

Electrical Specifications

Note*: Pulse output, alarm output and status output use the common terminal, therefore these functions are not used simultaneously.

Output Signal (◇): Dual Output (Both Analog and Transistor contact output can be obtained simultaneously). In this case refer to the item "Remarks on installation" for power supply and pulse output wiring.

Analog: 4 to 20 mA DC, 2-wire system.

Transistor Contact Output*:

Open collector, 3-wire system.
 Pulse, alarm, status output are selected by parameter setting.
 Contact rating: 10.5 to 30 V DC, 120 mA DC*1
 Low level: 0 to 2 V DC. (refer to Figure3)
 *1: 10.5 to 30 V DC. 80 mA DC for ATEX Intrinsically Safe Approval (KS2) and IECEx Intrinsically Safe Approval (/SS2)

Communication Requirements:

Communication Signal:

BRAIN or HART communication signal (superimposed on a 4 to 20 mA DC signal)
 Note: HART is a registered trademark of the HART Communication Foundation.

Conditions of Communication Line:

Load Resistance:
 250 to 600 Ω (including cable resistance).
 Refer to Figure 2.

Supply Voltage:
 16.4 to 42 V DC for digital communications BRAIN and HART protocols. (16.4 to 30 V DC for intrinsically safe type).
 Refer to Figure 2.

BRAIN:

Space from other Power Line: 15cm or more (Parallel wiring should be avoided.)

Communication Distance:
 Up to 2 km, when polyethylene insulated PVC-sheathed cables (CEV cables) are used. Communication distance varies depending on type of cable used and wiring.

Load Capacitance: 0.22 μF or less

Load Inductance: 3.3 mH or less

Input Impedance Communicating Device:
 10 kΩ or more at 2.4 kHz.

Selection of HART 5/ HART 7

Output Signal Code		-E	-J	
Ordering Information		—	Specify "5"	Specify "7"
HART Protocol Revision		HART 5		HART 7
Selection guide	Requirement for HART 7 functionality	NO		YES Be sure to confirm the protocol revision of the HART configuration tool shown in *2.
	Other conditions	Not available to switch to HART 7 protocol after delivery.	Available to switch to HART 7 protocol after delivery by user configuration.	—
Remarks		*1	*2	*2

*1: "-E" is HART5 exclusive model and will be terminated. "-J" is recommended for HART communication.
 *2: HART protocol revision for the device and HART configuration tool HART7 communication is supported by FieldMate R2.02 or later.

HART protocol revision and availability

	Protocol revision supported by HART configuration tool	
	5	7
DY or DYA HART 5	Available	Available
DY or DYA HART 7	Not Available	Available

Note: Protocol revision supported by HART configuration tool must be the same or higher than that of the digital YEWFL0.

Functions:

Damping Time Constant:

0 to 99 Sec (63% response time)
 Note: Delay time is 0.5 Sec.
 Analog output circuit time constant is 0.3 Sec.

Pulse Output Function*:

Pulse output is selected from scaled pulse, unscaled pulse, frequency (number of pulses output per second at 100% of output).
 Pulse frequency: Max 10 kHz
 Duty cycles: Approx. 50% (1:2 to 2:1)

Self-diagnostics and Alarm Output*:

In case alarm (over range output signal, EEPROM error, vibration noise, abnormal flow such as clogging, bubble) occurs, an alarm signal is output and indicated.

The alarm signal output goes from close (ON) to open (OFF) during alarming.

Analog Output Function:

Analog output is selected from flowrate and temperature value when option code /MV is selected.

Status Output Function*:

Flow Switch:

In case flow rate decreases under the flow set value, a status signal is output.
 Status signal output mode can reverse (ON/ OFF).

Data Security During Power Failure:

Data (parameter, totalizer value, etc) storage by EEPROM. No back-up battery required.

Correction:

Instrument Error Correction:

Vortex flowmeter instrument errors can be corrected by segment approximations.

Reynolds Number Correction:

Output error at Reynolds number 20000 or less is corrected by using five-break-point line-segment approximation.

Gas Expansion Correction:

When measuring a compressibility gas and steam, this expansion factor is useful to correct the error at high velocity of flow (35m/s or more).

Down-scale or Up-scale burn out.

In case a CPU or EEPROM failure occurs, flow meter output the signal of Up-scale (21.6 mA or more).

Up-scale or Down-scale (3.6 mA or less) is user-selectable through the fail mode alarm jumper.

Indicator:

Flow rate (% or engineering units) or temperature value and totalizer can be indicated simultaneously.

Short message for self diagnostics indicated.

Local parameter setting can be operated by key switches.

In mounting direction, the right and left 90° is rotatable.

EMC Conformity Standards:

EN 61326-1: 2006 Class A, Table 2 (For use in industrial locations), EN 61326-2-3: 2006

Note1: This instrument is a Class A product, and it is designed for use in the industrial environment. Please use this instrument in the industrial environment only.

Note2: Use the metal conduit for the remote cable.

Pressure Equipment Directive:

Type of equipment: piping
 Type of fluid: liquid and gas
 Group of fluid: 1 and 2
 Module: H

MODEL	DN(mm)*	PS(MPa)*	PS-DN(MPa·mm)	CATEGORY**
DY015	15	42	630	Article 3,*** Paragraph 3
DY025	25	42	1050	Article 3,*** Paragraph 3
DY040	40	42	1680	II
DY050	50	42	2100	II
DY080	80	42	3360	II
DY100	100	42	4200	II
DY150	150	42	6300	III
DY200	200	42	8400	III
DY250	250	42	10500	III
DY300	300	42	12600	III
DY400	400	25	10000	III

* PS: Maximum allowable pressure for Flow tube, DN: Nominal size

** Referred to Table 6 covered by ANNEX II of EC Directive on Pressure Equipment Directive 97/23/EC

*** Sound Engineering Practice (SEP)

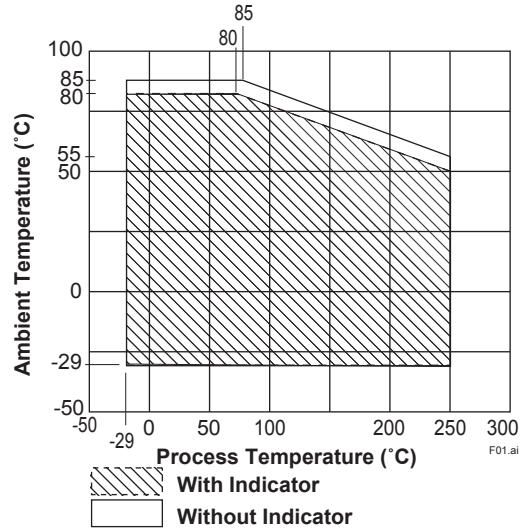

Figure 1 Ambient Temperature limit (Integral Type)

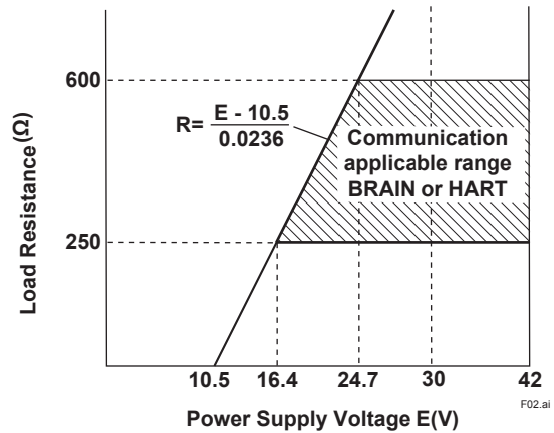

Figure 2 Relationship Between Power Supply and Load Resistance

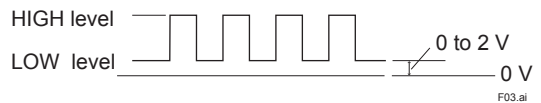

Figure 3 High and low level (Pulse output)

MODEL AND SUFFIX CODES

DY Vortex Flowmeter (Integral Type, Remote Type detector)

Model	Suffix Codes	Description
DY015	Size 15 mm (1/2 inch)
DY025	Size 25 mm (1 inch)
DY040	Size 40 mm (1-1/2 inch)
DY050	Size 50 mm (2 inch)
DY080	Size 80 mm (3 inch)
DY100	Size 100 mm (4 inch)
DY150	Size 150 mm (6 inch)
DY200	Size 200 mm (8 inch)
DY250	Size 250 mm (10 inch)
DY300	Size 300 mm (12 inch)
DY400	Size 400 mm (16 inch)
Output Signal /Communication	-D.....	4 to 20 mA DC, Pulse, BRAIN Communication
	-E.....	4 to 20 mA DC, Pulse, HART Communication *1
	-J.....	4 to 20 mA DC, Pulse, HART 5/HART 7 Communication *2
	-F.....	Digital communication (FOUNDATION Fieldbus protocol) *3
	-N.....	Remote type detector
Body Material *6, *7	A.....	JIS SCS14 A *4
	B.....	ASTM CF8M *5
	X.....	Others
Shedder bar Material *6, *7	L.....	Duplex Stainless Steel
	B.....	Stainless Steel
	E.....	Duplex Stainless Steel (for TIIS Approval)
	X.....	Others
Process Connection *8	AJ1.....	JIS 10 K Wafer
	AJ2.....	JIS 20 K Wafer
	AJ4.....	JIS 40 K Wafer
	AA1.....	ANSI Class 150 Wafer
	AA2.....	ANSI Class 300 Wafer
	AA4.....	ANSI Class 600 Wafer
	AD1.....	DIN PN10 Wafer
	AD2.....	DIN PN16 Wafer
	AD3.....	DIN PN25 Wafer
	AD4.....	DIN PN40 Wafer
	BJ1.....	JIS 10K Flange(RF)
	BJ2.....	JIS 20K Flange(RF)
	BJ4.....	JIS 40K Flange(RF)
	BA1.....	ANSI Class 150 Flange(RF)
	BA2.....	ANSI Class 300 Flange(RF)
	BA4.....	ANSI Class 600 Flange(RF)
BA5.....	ANSI Class 900 Flange(RF)	
RF: Raised Face SF: Smooth Finish RJ: Ring Joint	BS1.....	ANSI Class 150 Flange(RF, SF)
	BS2.....	ANSI Class 300 Flange(RF, SF)
	BS4.....	ANSI Class 600 Flange(RF, SF)
	BS5.....	ANSI Class 900 Flange(RF, SF)
	BD1.....	DIN PN10 Flange(RF)
BD2.....	DIN PN16 Flange(RF)	
BD3.....	DIN PN25 Flange(RF)	
BD4.....	DIN PN40 Flange(RF)	
CA4.....	ANSI Class 600 Flange(RJ)	
CA5.....	ANSI Class 900 Flange(RJ)	
Electrical Connection *9	-0.....	JIS G 1/2 Female
	-2.....	ANSI 1/2 NPT Female *10
	-4.....	ISO M201.5 Female
Indicator *11	D.....	With Indicator
	N.....	None Indicator, Remote type detector
Options	/□	Refer to Option Specifications

- *1: Output signal code '-E': HART 5. (Output signal code '-J' is recommended for HART communication.)
- *2: Output signal code '-J': HART 5 or HART 7 selectable. Specify HART 5 or HART 7 when ordering.
- *3: For FOUNDATION Fieldbus protocol, refer to GS 01F06F01-01EN. For Fieldbus communication type, there are not setting keys on the display board.
- *4: In case of A (JIS SCS14A), the process connection is available for JIS (AJ□, BJ□).
- *5: In case of B (ASTM CF8M), the process connection is available for ANSI (AA□, BA□, BS□, CA□) and DIN (AD□, BD□).
- *6: Refer to Table 1.
- *7: Users must consider the characteristics of selected wetted parts material and the influence of process fluids. The use of inappropriate materials can result in the leakage of corrosive process fluids and cause injury to personnel and/or damage to plant facilities. It is also possible that the instrument itself can be damaged and that fragments from the instrument can contaminate the user's process fluids.
Be very careful with highly corrosive process fluids such as hydrochloric acid, sulfuric acid, hydrogen sulfide, sodium hypochlorite, and high temperature steam (+150°C [+302°F] or above). Contact Yokogawa for detailed information of the wetted parts material.
- *8: Refer to Table 2.
- *9: In case of an explosion protect type, it depends for an electrical connection on the kind of an explosion protect type. Refer to "OPTION SPECIFICATIONS (FOR EXPLOSION PROTECTED TYPE)".
- *10: In case of /FF1 or /CF1, CF11, /KF2, /KS2, /SF2, /SS2 the screw length is deeper than ANSI standard for 0.5 to 2 threads.
- *11: Indicator is not available for remote type detector.
- *12: DY□□□/MV and DY□□□-N**/MV should be combined.
- *13: One set of end finish part is attached.
- *14: DYC Signal Cable can be used up to 30m. When you divide the cable below 30m, select the Cable End code [-0].

DYA Vortex Flowmeter Converter(Remote Type)

Model	Suffix Codes	Description
DYA	Vortex Flowmeter Converter (Remote Type)
Output Signal /Communication	-D.....	4 to 20 mA DC, Pulse BRAIN Communication
	-E.....	4 to 20 mA DC, Pulse HART Communication *1
	-J.....	4 to 20 mA DC, Pulse HART 5/HART 7 Communication *2
	-F.....	Digital communication (FOUNDATION Fieldbus protocol) *3
Electrical Connection *9	0.....	JIS G 1/2 Female
	2.....	ANSI 1/2 NPT Female *10
	4.....	ISO M20 ×1.5 Female
Indicator	D.....	With Indicator
	N.....	None Indicator
Options	/□ /MV	Refer to Option Specifications Multi-Variable Type *12

DYC Signal Cable

Model	Suffix Codes	Description
DYC	Signal Cable
Cable End	-0.....	Without End finish *13
	-1.....	With End finish
Cable Length *14	-05.....	5 m
	-10.....	10 m
	-15.....	15 m
	-20.....	20 m
	-25.....	25 m
	-30.....	30 m
	-35.....	35 m
	-40.....	40 m
	-45.....	45 m
	-50.....	50 m
	-55.....	55 m
	-60.....	60 m
	-65.....	65 m
	-70.....	70 m
-75.....	75 m	
-80.....	80 m	
-85.....	85 m	
-90.....	90 m	
-95.....	95 m	
Options	/C1.....	Cable End Finish Parts 1 set
	/C2.....	2 set
	/C3.....	3 set
	/C4.....	4 set
	/C5.....	5 set
	/C6.....	6 set
	/C7.....	7 set
	/C8.....	8 set
	/C9.....	9 set
/MV.....	Multi-Variable Type	

Table 1 Body, Shedder Bar and Gasket Material

Body Material

Model Code (Note3)			Standard (Note1)	Anti-Corrosion Version II (/HY) (Note2)	High Process Temperature Version (/HT) (Note2)	Cryogenic Version (/LT) (Note2)	NACE Material (/NC)
DY015	DY025/R1	DY040/R2					
DY025	DY040/R1	DY050/R2	A JIS SCS14A B ASTM CF8M	X (Note2) JIS SCS14A ASTM CF8M	X (Note2) JIS SCS14A ASTM CF8M	X (Note2) DIN1.4308 (JIS SCS13)	X ASTM CF8M
DY040	DY050/R1	DY080/R2					
DY050	DY080/R1	DY100/R2					
DY080	DY100/R1	DY150/R2					
DY100	DY150/R1	DY200/R2					
DY150	DY200/R1	—					
DY200	—	—					
DY250	—	—					
DY300	—	—					
DY400	—	—					

- (Note1) In case of the suffix code of the body material is [A], the code of the process connection is for one of AJ□,BJ□ or BP□. In case of the code [B], process connection code is for one of AA□,BA□,BS□,CA□,AD□ or BD□.
- (Note2) In cases of option code /HY, /HT, /LT or /NC, select [X] for both body material code and select shedder bar material code in accordance with the shedder bar material chart.
- (Note3) Reduced bore type is Flange type only.

Shedder Bar Material

Model Code (Note3)			Standard		Anti-corrosion version II (/HY) (Note1,2)	High Process Temperature Version (/HT) (Note1,2)	Cryogenic Version (/LT) (Note1,2)	NACE Material (/NC) (Note1,2)
DY015	DY025/R1	DY040/R2	L	E				
DY015	DY025/R1	DY040/R2	ASTM S31803	ASTM S31803	ASTM N10276	—	ASTM N10276	ASTM N10276
DY025	DY040/R1	DY050/R2	EN1.4517	EN1.4517	ASTM CW-12MW	ASTM CW-12MW	ASTM CW-12MW	ASTM CW-12MW
DY040	DY050/R1	DY080/R2						
DY050	DY080/R1	DY100/R2						
DY080	DY100/R1	DY150/R2						
DY100	DY150/R1	DY200/R2	EN1.4517	EN1.4517	—	ASTM CW-12MW or B	—	ASTM CF8M (Note4) (Note6)
DY150	DY200/R1	—						
DY200	—	—						
DY250	—	—						
DY300	—	—	B	B	—	ASTM CF8M (Note5) (Note6)	—	—
DY400	—	—						

- (Note1) Select body code [X] for /HY, /HT, /LT and /NC. Available to combine with TIIS Flame proof type /JF3 or Multi-Variable type /MV.
- (Note2) The shedder bar code [E] is for TIIS Flame proof type /JF3 only. Select shedder bar code [X] for DY025 to DY200 when you combine TIIS Flame proof type /JF3 with /HY, /HT, /LT or /NC.
- (Note3) Wafer type (Process Connection: A**): DY015 to DY100, Flange type (Process Connection: B**): DY015 to DY400. Reduced bore type is Flange type only.
- (Note4) Shedder bar code [X] or [B] is selectable for DY150/HT, DY150/NC, DY200/HT and DY200/NC.
- (Note5) Select shedder bar code only [B] for DY250/HT to DY400/HT.
- (Note6) Available to combine with TIIS Flame proof type /JF3, High Process Temperature Version (/HT) and shedder bar code [B] as TOKUCHU.

Gasket Material

Model Code (Note1)			Standard	Anti-corrosion Version II (/HY)	High Process Temperature Version (/HT)	Cryogenic Version (/LT)	NACE Material (/NC)
DY015	DY025/R1	DY040/R2					
DY025	DY040/R1	DY050/R2					
DY040	DY050/R1	DY080/R2	—	JIS SUS316 stainless steel plated with silver	—		
DY050	DY080/R1	DY100/R2					
DY080	DY100/R1	DY150/R2	—	—	—		
DY100	DY150/R1	DY200/R2					
DY150	DY200/R1	—	—	—	—		
DY200	—	—					
DY250	—	—	—	—	—		
DY300	—	—					
DY400	—	—	—	—	—	—	

(Note1) Wafer type (Process Connection: A□□): DY015 to DY100, Flange type (Process Connection: B□□): DY015 to DY400
Reduced bore type is Flange type only.

Table 2 Flowmeter Selection Guide

Process Connection	Wafer			Flange (Raised Face)			Flange (Ring Joint)			Flange (Raised Face, Smooth Finish)				
	Suffix Code	Model Code		Suffix Code	Model Code		Suffix Code	Model Code		Suffix Code	Model Code			
JIS 10 K	AJ1	DY015 to DY100	— —	BJ1	DY015 to DY400	DY025/R1 to DY200/R1	DY040/R2 to DY200/R2	—	—	—	—	—	—	
JIS 20 K	AJ2	DY015 to DY100	— —	BJ2	DY015 to DY400	DY025/R1 to DY200/R1	DY040/R2 to DY200/R2	—	—	—	—	—	—	
JIS 40 K	AJ4	DY015 to DY100	— —	BJ4	DY015 to DY150	—	—	—	—	—	—	—	—	
ANSI Class 150	AA1	DY015 to DY100	— —	BA1	DY015 to DY400	DY025/R1 to DY200/R1	DY040/R2 to DY200/R2	—	—	—	BS1	DY015 to DY400	DY025/R1 to DY200/R1	DY040/R2 to DY200/R2
ANSI Class 300	AA2	DY015 to DY100	— —	BA2	DY015 to DY400	DY025/R1 to DY200/R1	DY040/R2 to DY200/R2	—	—	—	BS2	DY015 to DY400	DY025/R1 to DY200/R1	DY040/R2 to DY200/R2
ANSI Class 600	AA4	DY015 to DY100	— —	BA4	DY015 to DY200	—	—	CA4	DY015 to DY200	—	BS4	DY015 to DY200	—	—
ANSI Class 900	—	—	— —	BA5	DY015 to DY200	—	—	CA5	DY015 to DY200	—	BS5	DY015 to DY200	—	—
DIN PN10	AD1	DY015 to DY100	— —	BD1	DY015 to DY200	—	—	—	—	—	—	—	—	—
DIN PN16	AD2	DY015 to DY100	— —	BD2	DY015 to DY200	—	—	—	—	—	—	—	—	—
DIN PN25	AD3	DY015 to DY100	— —	BD3	DY015 to DY200	—	—	—	—	—	—	—	—	—
DIN PN40	AD4	DY015 to DY100	— —	BD4	DY015 to DY200	—	—	—	—	—	—	—	—	—

(Note)
 • ANSI standardized types are worked by serration finishing except the Smooth Finish type.
 • The Smooth Finish type is shipped without serration finishing.
 • Refer to "OPTION REDUCED BORE TYPE (/R1, /R2)" (refer to P.11), when you select reduced bore type /R1, /R2.

■ OPTION SPECIFICATIONS

Item	Specification	Applicable Model	Code
Multi-Variable Type (Note 5)	Build in Temperature sensor (Pt 1000) in vortex shedder bar.	DY / DYA	MV
Reduced bore type (Note 8) (Note 12)	Integrated and welded construction with concentric reduced bore piping. R1: Detector size (B) is one meter body size down of digitalYEWFLOW to flange pipe size (A).	DY	R1
	R2: Detector size (B) is two meter body size down of digitalYEWFLOW to flange pipe size (A).		R2
Stainless Steel Tag Plate (Note 1)	JIS SUS304 tag plate, hung on the case.	DY / DYA	SCT
Stainless Steel Bolt & Nut Assembly	JIS SUS304 bolt/nut assembly. Used when a wafer type is installed.	DY Wafer Type	BL
Paint Color Change	Only for the covers: Refer to Table 3	DY / DYA	Refer to Table3
Hydrostatic / Pneumatic Test Certificate	Test pressure value is in accordance with Table 4. Test time: 10 minutes. Available for the Standard type. Test medium: Air, Nitrogen or Water.	DY	T01 (Note 11)
Hydrostatic Test Certificate	Test pressure value is in accordance with Table 4. Test time: 10 minutes. Available for the Standard type. Test medium: Water.	DY	T02 (Note 11)
Degrease Treatment (Note 2)	Degrease cleansing treatment.	DY	K1
Epoxy Coating	Epoxy coating for case and cover.	DY / DYA	X1
Piling up coating of epoxy and polyurethane	Epoxy and Polyurethane coating for the purpose of corrosion - proof improvement; salt damage, alkali, climate and acidity	DY / DYA	X2
High Process Temperature Version	This specification temperature is from -29 to +450 °C Refer to Table 1, Figure 4. Refer to Table 5 for minimum velocity. Refer to Note 5 for the combination of High Process Temperature Version (/HT) and Multi-Variable Type (/MV).	DY***-N	HT
Cryogenic Version (Note 7)	This specification temperature is from -196 to +100 °C Refer to Table 1, Figure 5. /R1 and /R2 are not available.	DY***-N	LT
Stainless Steel Bracket for Remote Converter (DYA)	The bracket material for remote converter type (DYA) is JIS SUS304.	DYA	SB
Lightning Protector	There is an arrester inside converter for power supply line. Maximum power supply voltage: 30VDC	DY Integral Type / DYA	A
NACE Material (Note 10)	Refer to Table 1.	DY	NC
Compliance with NAMUR (Note 6)	Compliance with NAMUR43. Current signal for measurement is 4mA up to 20.5mA. Set output 3.6mA or less when burn-out occurred.	DY / DYA	NM
Anti-corrosion Version II	Anti-corrosion Version II. Refer to Table 1. DY150/R1, DY150/R2, and DY200/R2 are not available.	DY	HY
Converter Installing Direction 180° Change (Note4)	Converter installing direction 180° change inversely when shipped.	DY	CRC
Down-scale burn-out in CPU or EEPROM failure (Note 3)	Set output 3.6mA or less when burn-out occurred.	DY Integral Type / DYA	C1
Stainless steel housing (Note 9)	Converter housing, case and cover material: JIS SCS14A or ASTM, ASME CF8M stainless steel castings. (equivalent to JIS SUS316)	DY***-N / DYA	E1
Flameproof Packing Adapter	Power source connection port and signal cable (remote type) connection port. JIS G1/2 female thread. Other cable shape: ø 8 to ø 12. /G11: One piece, /G12: Two pieces.	DY / JF3	G11
		DYA / JF3	G12
Calibration Certificate	Level 2 Declaration and Calibration Equipment List	DY / DYA	L2
	Level 3 Declaration and Primary Standard List	DY / DYA	L3
	Level 4 Declaration and YOKOGAWA Measuring	DY / DYA	L4
Material certificates: Mill sheets	Item to be specified	DY	1. Meterbody
			1. Meterbody, 2. Shedder bar
			1. Meterbody, 2. Shedder bar, 3. Bottom plug
			1. Meterbody, 2. Shedder bar, 3. Bottom plug, 4. Welding rod
Material certificates: 3.1	Item to be specified	DY	3.1 certificate to be attached according to EN10204.
			1. Meterbody
			1. Meterbody, 2. Shedder bar
			1. Meterbody, 2. Shedder bar, 3. Bottom plug
Material certificates: 3.1	Item to be specified	DY	1. Meterbody, 2. Shedder bar, 3. Bottom plug, 4. Welding rod
			1. Meterbody
			1. Meterbody, 2. Shedder bar
			1. Meterbody, 2. Shedder bar, 3. Bottom plug
PMI test certificate	Item to be specified	DY	Positive Material Identification certificate to be attached for the main 3 chemical components of specified materials. Each certificate to be attached.
			1. Meterbody
PMI test certificate	Item to be specified	DY	1. Meterbody, 2. Shedder bar
			1. Meterbody, 2. Shedder bar
ASME welding documents submission (Note 10)	Item to be specified	DY	1. Welder/Welding Operator Performance Qualification (or Welder Qualification Record) 2. Welding Procedure Specification (WPS) 3. Procedure Qualification Record (PQR) Each certificate to be attached. The customer's name and job name to be specified when ordered.
			1. Welded portion for the bottom plug 2. Welded portion for the flange in case of the welding construction
Dye Penetrant test certificate	Item to be specified	DY 2. is for DY250 to DY400.	Dye Penetrant test certificate for the welded portion to be attached. Each certificate to be attached.
			1. Welded portion for the bottom plug 2. Welded portion for the flange in case of the welding construction 3. Criterion: ASME B31.1

(Note 1) Up to 30 alphanumeric characters can be engraved on the stainless tag plate. Capital/small letters are available for BRAIN communication “-D” and FOUNDATION Fieldbus “-F”. Only capital letters are available for HART communication “-E” or “-J”.

(Note 2) There is a case that calibration water should stay in the meter tube. So this is not degrease treatment in the strict sense.

(Note 3) The output is set 3.6mA or less (Standard type is set 21.6mA or more at shipping).

- (Note 4) The electrical connection turn to a downstream side.
- (Note 5) Refer to "OPTION MULTI-VARIABLE (BUILD-IN TEMPERATURE SENSOR) TYPE (/MV)" (P.10)
In case of Remote type detector (DY***-N), select "/MV" both DY and DYA.
- (Note 6) /NM can not combine with Remote type (DY***-N).
- (Note 7) ATEX Flameproof Approval /KF2 and IECEx Flameproof Approval /SF2 are not Available.
- (Note 8) • Cryogenic version /LT is not available.
• High process temperature version /HT and Multi-variable type /MV for DY025/R1 and DY040/R2 is not available.
• Flange type only and available process connections are JIS10k, 20k (BJ1, BJ2) and ANSI class 150, 300 (BA1,BA2,BS1,BS2).
• Model Code (A) means "DY***" nominal size.
- (Note 9) • Applicable for Option code /FF1, /KF2, /KS2, /FS1, /SF2 and /SS2.
• Not applicable for Option code /P1, /P2, /P7, /X1, /X2, /HT, /LT, /SB /JF3, /FS1, /CF1, /CS1, /CF11 and /CS11.
• The materials of exterior parts, name plate, screw, bolts on the stainless steel housing and bracket, u-bolt, nuts for DYA/E1 and tag plate for /E1/SCT are JIS SUS316 or SUS316L.
- (Note 10) The wetted parts materials conform to NACE material recommendations per MR0175.
NACE Material /NC can not combine with ASME welding documents submission /WP.
- (Note 11) /T01 and /T02 can be selected only one code either.
- (Note 12) Refer to "OPTION REDUCED BORE TYPE (/R1, /R2)" (P.11)

Table 3 Paint Color and Codes

Codes	Munsell Renotation Code	Color
P1	N1.5	Black
P2	7.5BG4/1.5	Shade green
P7	—	Metallic silver

Table 4 Test Pressure Value

Flange Rating	Pressure
JIS 10 K	2.1 MPa
JIS 20 K	5.0 MPa
JIS 40 K	10.0 MPa
ANSI Class 150	2.9 MPa
ANSI Class 300	7.5 MPa
ANSI Class 600	14.9 MPa
ANSI Class 900	22.4 MPa
DIN PN 10	1.5 MPa
DIN PN 16	2.4 MPa
DIN PN 25	3.8 MPa
DIN PN 40	5.9 MPa

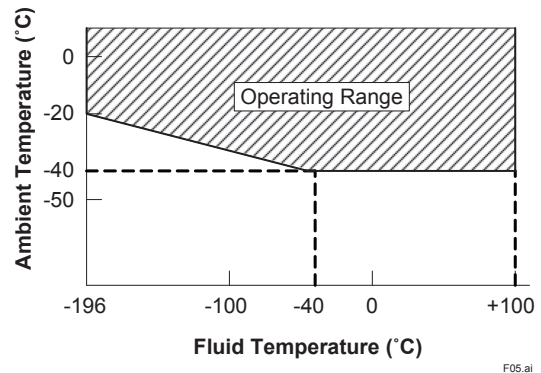

Figure 5 Fluid Temperature Range of Cryogenic Version

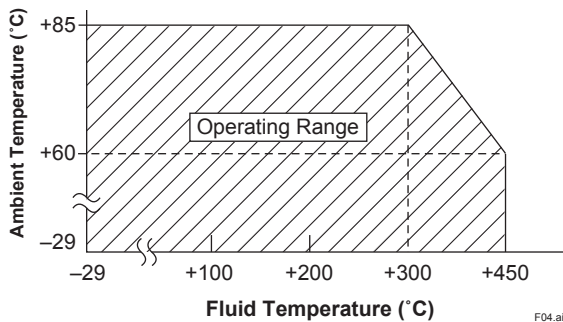

Figure 4 Fluid Temperature Range of High Process Temperature Version

■ OPTION MULTI-VARIABLE (BUILT-IN TEMPERATURE SENSOR) TYPE (/MV)

This options is the same as standard specification except the following items.

Multi-Variable (Built-in Temperature sensor) Type (Option Code: /MV) (Note1) High Process Temperature Version Multi-Variable Type (Option Code: /HT/MV)							
Model code		DY025 to DY100 (Wafer) DY025 to DY200 (Flange)					
Function (Note2)		Temperature Indication / Output	Mass Flow Calculation (Volumetric flowrate at Standard Condition for GAS)				
Fluid		LIQUID, GAS, SATURATED STEAM, SUPERHEATED STEAM (Note3)	SATURATED STEAM (Note4)	SUPERHEATED STEAM (Note5)	GAS (Note6)	LIQUID (Note7)	
Mass Flow Calculation	Calculation Temperature Range	Option Code: /MV	/	+100 to +250°C	+100 to +250°C	-29 to +250°C	-29 to +250°C
		Option Code: /HT/MV	/	+100 to +330°C	+100 to +400°C	-29 to +400°C	-29 to +400°C
	Accuracy (Note8)	Option Code: /MV /HT/MV	(Note8)				
Temperature	Temperature Range	Option Code: /MV	-29 to +250°C				
		Option Code: /HT/MV	-29 to +400°C				
	Accuracy	Option Code: /MV	/	±0.5°C(less than +100°C) ±0.5% of rate (+100°C or more)	±1°C(less than +100°C) ±1% of rate (+100°C or more)		
		Option Code: /HT/MV	/	±1°C (less than +100°C) ±1% of rate (+100°C or more)			
Temperature Response (50% Response)		60 sec (Churning Underwater)					
Output	Analog Output		Select from Flow Rate or Temperature (Note9)				
	Pulse Output		Flow Rate: Same as Standard Type				
	Alarm Output		Alarm Output same as Standard Type and Temperature Sensor Error, etc.				
	Status Output		Flow Switch (Flow Rate): Same as Standard Type				
Display	Upper		Select from Flow Rate (% , Engineering Unit) or Temperature (%) (Note10)				
	Lower		Select from Total Rate or Temperature (°C, °F) (Note11)				
Remote Type		Select Vortex Flow Converter DYA-□□□/MV and Signal Cable DYC-□□□/MV (Note12)					

- (Note1) Multi-Variable Type /MV can not be combined with Cryogenic Version /LT.
- (Note2) Temperature measurement may be affected by installation conditions, such as thermal insulation of piping or the temperature distribution of the fluid. Refer to "REMARKS ON INSTALLATION" for thermal insulation of piping. When measuring mass flow of saturated steam, superheated steam thermal insulation of piping may be required.
- (Note3) Measured temperature is not used for flow measurement.
- (Note4) Mass flow rate is calculated from density calculated with density at the measured temperature derived by the built-in saturated steam table.
- (Note5) Mass flow rate is calculated with the density at the measured temperature derived by the built-in steam table. For mass flow calculation of superheated steam, operating pressure is used as constant value.
- (Note6) Volumetric flow rate is calculated by temperature/pressure compensation. For volumetric flow calculation of gas, operating pressure and pressure at standard/normal condition are used.
- (Note7) Mass flow rate is calculated with density compensated by the secondary formula of measured temperature. Operating density is used as a base density and the 1st and 2nd coefficients have to be set.
- (Note8) Refer to the "Detailed Accuracy" (P.13, P.14).
- (Note9) The factory setting is the flow rate output. When the temperature output is required, it is necessary to change the parameter.
- (Note10) In case of indicating the temperature %, the display indicate not only "%" but also "t". ("t" means temperature).
- (Note11) Default setting is "Temperature" but "Total" is set when the total rate is specified in sizing data.
- (Note12) In case of remote type, option code /MV is necessary for both Vortex Flow Converter (DYA) and Signal Cable (DYC). To correct the temperature error due to signal cable length, parameter setting of the signal cable length to Vortex Flow Converter (DYA) is required.

■ OPTION REDUCED BORE TYPE (/R1, /R2)

This option is the same as standard specification except the following items.

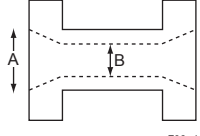
		Reduced Bore Type (Option: /R1, /R2) (Note1)			
		Model Code	Flange piping size (A)	R1 Detector size (inner dia.) (B)	R2 Detector size (inner dia.) (B)
(Note 2)  F06.ai	DY025	25mm	15 (14.6) (mm) (Note 3)		[Pressure Loss] R1: about 15% increases to standard type. R2: about 28% increases to standard type. Refer to P.18
	DY040	40mm	25 (25.7) (mm)	15 (14.6) (mm) (Note 3)	
	DY050	50mm	40 (39.7) (mm)	25 (25.7) (mm)	
	DY080	80mm	50 (51.1) (mm)	40 (39.7) (mm)	
	DY100	100mm	80 (71) (mm)	50 (51.1) (mm)	
	DY150	150mm	100 (93.8) (mm)	80 (71) (mm)	
	DY200	200mm	150 (138.8) (mm)	100 (93.8) (mm)	
Measurable minimum flow velocity	Liquid, Gas, Steam			Refer to Table 5.	
Range of measurable flow velocity	Liquid, Gas, Steam			Refer to Table 6.	

(Note 1) For accuracy, refer to “Detailed Accuracy”(P.13, P.14). Cryogenic Version /LT is not available.

(Note 2) Flange type only: JIS10K, 20K (BJ1, BJ2) and ANSI150, 300 (BA1, BA2, BS1, BS2)

(Note 3) High process temperature version /HT and Multi-variable type /MV for DY025/R1 and DY040/R2 are not available.

■ SIZING

The following items are the basic specifications.

In case of the definite sizing, it is necessary to check by the sizing software.

■ Measurable minimum flow velocity

Table 5 Relationship between Minimum Velocity and Density

Model Code			Liquid		Gas, Steam (Note1)	
Standard Type, Multi-Variable Type(/MV)	Reduced Bore Type (/R1) (Note2)	Reduced Bore Type (/R2) (Note2)	Standard Type, Cryogenic Version (/LT)(Note2), Multi-Variable Type (/MV) Unit: m/s	High Process Temperature Version(/HT), High Process Temperature Version Multi-Variable Type (/HT/MV) Unit: m/s	Standard Type, Cryogenic Version (/LT)(Note2), Multi-Variable Type (/MV) Unit: m/s	High Process Temperature Version(/HT), High Process Temperature Version Multi-Variable Type (/HT/MV) Unit: m/s
DY015	DY025/R1	DY040/R2	$\sqrt{250/\rho}$	—	$\sqrt{80/\rho}$ or 3	—
DY025	DY040/R1	DY050/R2	$\sqrt{122.5/\rho}$	$\sqrt{490/\rho}$	$\sqrt{45/\rho}$ or 2	$\sqrt{125/\rho}$ or 2
DY040	DY050/R1	DY080/R2	$\sqrt{90/\rho}$	$\sqrt{302.5/\rho}$	$\sqrt{31.3/\rho}$ or 2	$\sqrt{90.3/\rho}$ or 2
DY050	DY080/R1	DY100/R2	$\sqrt{90/\rho}$	$\sqrt{160/\rho}$	$\sqrt{31.3/\rho}$ or 2	$\sqrt{61.3/\rho}$ or 2
DY080	DY100/R1	DY150/R2	$\sqrt{90/\rho}$	$\sqrt{160/\rho}$	$\sqrt{31.3/\rho}$ or 2	$\sqrt{61.3/\rho}$ or 2
DY100	DY150/R1	DY200/R2	$\sqrt{90/\rho}$	$\sqrt{160/\rho}$	$\sqrt{31.3/\rho}$ or 2	$\sqrt{61.3/\rho}$ or 2
DY150	DY200/R1	—	$\sqrt{90/\rho}$	$\sqrt{160/\rho}$	$\sqrt{31.3/\rho}$ or 3	$\sqrt{61.3/\rho}$ or 3
DY200	—	—	$\sqrt{122.5/\rho}$	$\sqrt{202.5/\rho}$	$\sqrt{45/\rho}$ or 3	$\sqrt{80/\rho}$ or 3
DY250	—	—	$\sqrt{160/\rho}$	$\sqrt{360/\rho}$	$\sqrt{61.3/\rho}$ or 3	$\sqrt{125/\rho}$ or 3
DY300	—	—	$\sqrt{160/\rho}$	$\sqrt{360/\rho}$	$\sqrt{61.3/\rho}$ or 3	$\sqrt{125/\rho}$ or 3
DY400	—	—	$\sqrt{250/\rho}$	$\sqrt{490/\rho}$	$\sqrt{80/\rho}$ or 4	$\sqrt{125/\rho}$ or 4

ρ : Density at operating conditions (kg/m³), Liquid density range is 400 to 2000 kg/cm³

(Note1) The case of gas, it is whichever is greater than a fixed value of each model and calculated from density.

(Note2) Reduced bore type /R1 or /R2 are not available to combine for Cryogenic Version /LT.

■ Range of measurable flow velocity

Table 6 Range of measurable flow velocity

Fluid	Model Code			Minimum flow velocity	Maximum flow velocity
Liquid	DY015 to DY400	DY025 /R1 to DY200 /R1	DY040 /R2 to DY200 /R2	“flow velocity obtained from Table 5” or “flow velocity at Reynolds number of 5000”, whichever is greater. For liquid Reynolds number of 5000: Refer to P.15 “Calculation formula”.	10m/s
Gas, Steam	DY015 to DY400	DY025 /R1 to DY200 /R1	DY040 /R2 to DY200 /R2	“flow velocity obtained from Table 5” or “flow velocity at Reynolds number of 5000”, whichever is greater. For Gas and steam Reynolds number of 5000: Refer to P.15 “Calculation formula”.	80m/s

When the flow velocity is lower than minimum, both the analog output and the pulse output is displayed as “0”.

■ Range of fixed accuracy flow velocity

Table 7 Range of fixed accuracy flow velocity

Fluid	Model Code			Minimum flow velocity	Maximum flow velocity
Liquid	DY015 to DY100	DY025 /R1 to DY150 /R1	DY040 /R2 to DY200 /R2	“flow velocity obtained from Table 5” or “flow velocity at Reynolds number of 20000”, whichever is greater. For liquid Reynolds number of 20000: The value is four times velocity value in P.15 “Calculation formula”.	10m/s
	DY150 to DY400	DY200 /R1	—	“flow velocity obtained from Table 5” or “flow velocity at Reynolds number of 40000”, whichever is greater. For liquid Reynolds number of 40000: The value is eight times velocity value in P.15 “Calculation formula”.	
Gas, Steam	DY015 to DY100	DY025 /R1 to DY150 /R1	DY040 /R2 to DY200 /R2	“flow velocity obtained from Table 5” or “flow velocity at Reynolds number of 20000”, whichever is greater. For gas and steam Reynolds number of 20000: Refer to P.15 “Calculation formula”.	80m/s
	DY150 to DY400	DY200 /R1	—	“flow velocity obtained from Table 5” or “flow velocity at Reynolds number of 40000”, whichever is greater. For gas and steam Reynolds number of 40000: Refer to P.15 “Calculation formula”.	

■ DETAILED ACCURACY

Accuracy is the value in range of fixed accuracy flow velocity. Refer to Table 7.

Volumetric flow rate at operation condition

	Model Code	Standard Type	Multi-Variable Type (/MV)	Reduced Bore Type (/R1)	Reduced Bore Type (/R2)
Liquid	DY015	±1.0% (20000≤Re<2000*D) ±0.75% (2000*D≤Re)			
	DY025	±1.0% (20000≤Re<1500*D) ±0.75% (1500*D≤Re)	±1.0% (20000≤Re<1500*D) ±0.75% (1500*D≤Re)	±1.0%	±1.0%
	DY040	±1.0% (20000≤Re<1000*D) ±0.75% (1000*D≤Re)	±1.0% (20000≤Re<1000*D) ±0.75% (1000*D≤Re)		
	DY050				
	DY080				
	DY100				
	DY150	±1.0% (40000≤Re<1000*D) ±0.75% (1000*D≤Re)	±1.0% (40000≤Re<1000*D) ±0.75% (1000*D≤Re)	±1.0% (40000≤Re)	
	DY200				
	DY250				
	DY300				
DY400					
Gas, Steam	DY015	±1.0% (Velocity 35m/s or less) ±1.5% (Velocity 35m/s to 80m/s)			
	DY025				
	DY040				
	DY050		±1.0% (Velocity 35m/s or less) ±1.5% (Velocity 35m/s to 80m/s)	±1.0% (Velocity 35m/s or less) ±1.5% (Velocity 35m/s to 80m/s)	±1.0% (Velocity 35m/s or less) ±1.5% (Velocity 35m/s to 80m/s)
	DY080				
	DY100				
	DY150				
	DY200				
	DY250				
	DY300				
DY400					

D: Inner diameter of digitalYEWFL0 (mm)

Re: Reynolds number (non unit)

Note: This table shows the accuracy of pulse output. In case of analog output, add up ± 0.1% of full scale to the values mentioned above.

Guarantee conditions of liquid volumetric flow rate: the accuracy of a product before shipment in our water actual test facility.

Totalized value of 2000 pulse or greater, straight pipe length: upper 10D or greater, lower 5D or greater, Fluid temp. 20 ± 10°C

Gas, Steam: The accuracy which is add up from liquid measurement accuracy.

The accuracy is confirmed by actual measured value of typical nominal size.

**Mass flow or Volumetric flow rate at Normal/Standard condition:
for Multi-Variable Type and combination of Multi-Variable Type and Reduced Bore Type**

	Model Code	/MV	/MV/R1	/MV/R2	
Liquid	DY025	$\pm 2.0\%$ ($20000 \leq Re < 1500 \cdot D$) $\pm 1.5\%$ ($1500 \cdot D \leq Re$)			
	DY040	$\pm 2.0\%$ ($20000 \leq Re < 1000 \cdot D$) $\pm 1.5\%$ ($1000 \cdot D \leq Re$)	$\pm 2.0\%$ ($20000 \leq Re$)	$\pm 2.0\%$ ($20000 \leq Re$)	
	DY050				
	DY080				
	DY100	$\pm 2.0\%$ ($40000 \leq Re < 1000 \cdot D$) $\pm 1.5\%$ ($1000 \cdot D \leq Re$)	$\pm 2.0\%$ ($40000 \leq Re$)	$\pm 2.0\%$ ($40000 \leq Re$)	$\pm 2.0\%$ ($20000 \leq Re$)
	DY150				
	DY200				
Gas, Steam	DY025	$\pm 2.0\%$ (Velocity 35m/s or less) $\pm 2.5\%$ (Velocity 35m/s to 80m/s)	$\pm 2.0\%$ (Velocity 35m/s or less) $\pm 2.5\%$ (Velocity 35m/s to 80m/s)	$\pm 2.0\%$ (Velocity 35m/s or less) $\pm 2.5\%$ (Velocity 35m/s to 80m/s)	
	DY040				
	DY050				
	DY080				
	DY100				
	DY150				
	DY200				

D: Inner diameter of digital YEW FLO (mm)

Re: Reynolds number (non unit)

Note: This table shows the accuracy of pulse output. In case of analog output, add up $\pm 0.1\%$ of full scale to the values mentioned above.

for High Temperature Version Multi-Variable Type and combination of High Temperature Multi-Variable Type and Reduced Bore Type

	Model Code	/HT/MV	/HT/MV/R1	/HT/MV/R2	
Liquid	DY025	$\pm 2.0\%$ ($20000 \leq Re < 1500 \cdot D$) $\pm 1.5\%$ ($1500 \cdot D \leq Re$)			
	DY040	$\pm 2.0\%$ ($20000 \leq Re < 1000 \cdot D$) $\pm 1.5\%$ ($1000 \cdot D \leq Re$)	$\pm 2.0\%$ ($20000 \leq Re$)	$\pm 2.0\%$ ($20000 \leq Re$)	
	DY050				
	DY080				
	DY100	$\pm 2.0\%$ ($40000 \leq Re < 1000 \cdot D$) $\pm 1.5\%$ ($1000 \cdot D \leq Re$)	$\pm 2.0\%$ ($40000 \leq Re$)	$\pm 2.0\%$ ($40000 \leq Re$)	$\pm 2.0\%$ ($20000 \leq Re$)
	DY150				
	DY200				
Gas, Superheated Steam	DY025	$\pm 2.0\%$ (Velocity 35m/s or less) $\pm 2.5\%$ (Velocity 35m/s to 80m/s)	$\pm 2.0\%$ (Velocity 35m/s or less) $\pm 2.5\%$ (Velocity 35m/s to 80m/s)	$\pm 2.0\%$ (Velocity 35m/s or less) $\pm 2.5\%$ (Velocity 35m/s to 80m/s)	
	DY040				
	DY050				
	DY080				
	DY100				
	DY150				
	DY200				
Saturated Steam	DY025	$\pm 3.0\%$ (Velocity 35m/s or less) $\pm 3.5\%$ (Velocity 35m/s to 80m/s)	$\pm 3.0\%$ (Velocity 35m/s or less) $\pm 3.5\%$ (Velocity 35m/s to 80m/s)	$\pm 3.0\%$ (Velocity 35m/s or less) $\pm 3.5\%$ (Velocity 35m/s to 80m/s)	
	DY040				
	DY050				
	DY080				
	DY100				
	DY150				
	DY200				

D: Inner diameter of digital YEW FLO (mm)

Re: Reynolds number (non unit)

Note: This table shows the accuracy of pulse output. In case of analog output, add up $\pm 0.1\%$ of full scale to the values mentioned above.

■ **Calculation formula**

- How to calculate volume flow rate at operating conditions.

$$Q_f = 3600 \times v \times S \text{ or } Q_f = \frac{v \times D^2}{354}$$

- How to calculate the velocity of a Reynolds number.

- $v = 5 \times v / D$ (Reynolds number of 5000)
- $v = 20 \times v / D$ (Reynolds number of 20000)
- $v = 40 \times v / D$ (Reynolds number of 40000)

where

$$Re = \frac{354 \times 10^3 \times Q_f}{v \times D} \dots\dots\dots (1)$$

$$v = \frac{\mu}{\rho_f} \times 10^3 \dots\dots\dots (2)$$

- Q_f : Volume flow rate at operating conditions (m³/h)
- D : Inner diameter of digitalYEWFLO (mm)
- S : Sectional area of digitalYEWFLO (m²)
- v : Flow velocity (m/s)
- Re: Reynolds number (non unit)
- ρ_f : Density at operating conditions (kg/m³)
- μ : Viscosity at operating conditions (mPa·s (cP))
- v : Kinematic viscosity at operating conditions (10⁻⁶m²/s (cSt))

■ **Typical fluid example**

Table 8 Range of Measurable Water Flow Rate
(At standard condition of 15°C, $\rho = 1000 \text{ kg/m}^3$)

Model Code			Measurable Flow Rate in m ³ /h	Range of Fixed Accuracy Flow Rate in m ³ /h
DY015	DY025/R1	DY040/R2	0.30 to 6	0.94 to 6
DY025	DY040/R1	DY050/R2	0.65 to 18	1.7 to 18
DY040	DY050/R1	DY080/R2	1.3 to 44	2.6 to 44
DY050	DY080/R1	DY100/R2	2.2 to 73	3.3 to 73
DY080	DY100/R1	DY150/R2	4.3 to 142	4.6 to 142
DY100	DY150/R1	DY200/R2	7.5 to 248	7.5 to 248
DY150	DY200/R1	—	17 to 544	18 to 544
DY200	—	—	34 to 973	34 to 973
DY250	—	—	60 to 1506	60 to 1506
DY300	—	—	86 to 2156	86 to 2156
DY400	—	—	177 to 3547	177 to 3547

Table 9 Range of Measurable Air Flow Rate at Selected Process Pressures

Model Code			Flow Rate Limits	Minimum and Maximum Measurable Flow Rate in Nm ³ /h									
				0 MPa	0.1 MPa	0.2 MPa	0.4 MPa	0.6 MPa	0.8 MPa	1 MPa	1.5 MPa	2 MPa	2.5 MPa
DY015	DY025 /R1	DY040 /R2	min.	4.8(11.1)	6.7(11.1)	8.2(11.1)	10.5(11.1)	12.5	16.1	19.7	28.6	37.5	46.4
			max.	48.2	95.8	143	239	334	429	524	762	1000	1238
DY025	DY040 /R1	DY050 /R2	min.	11.0(19.5)	15.5(19.5)	19.0(19.5)	24.5	29.0	33.3	40.6	59.0	77.5	95.9
			max.	149	297	444	739	1034	1329	1624	2361	3098	3836
DY040	DY050 /R1	DY080 /R2	min.	21.8(30.0)	30.8	37.8	48.7	61.6	79.2	97	149	184	229
			max.	356	708	1060	1764	2468	3171	3875	5634	7394	9153
DY050	DY080 /R1	DY100 /R2	min.	36.2(38.7)	51	62.4	80.5	102	131	161	233	306	379
			max.	591	1174	1757	2922	4088	5254	6420	9335	12249	15164
DY080	DY100 /R1	DY150 /R2	min.	70.1	98.4	120	155	197	254	310	451	591	732
			max.	1140	2266	3391	5642	7892	10143	12394	18021	23648	29274
DY100	DY150 /R1	DY200 /R2	min.	122	172	211	272	334	442	540	786	1031	1277
			max.	1990	3954	5919	9847	13775	17703	21632	31453	41274	51095
DY150	DY200 /R1	—	min.	268	377	485	808	1131	1453	1776	2583	3389	4196
			max.	4358	8659	12960	21559	30163	38765	47365	68867	90373	111875
DY200	—	—	min.	575	809	990	1445	2202	2599	3175	4617	6059	7501
			max.	7792	15482	23172	38549	53933	69313	84693	123138	161591	200046
DY250	—	—	min.	1037	1461	1788	2306	3127	4019	4911	7140	9370	11600
			max.	12049	23939	35833	59611	83400	107181	130968	190418	249881	309334
DY300	—	—	min.	1485	2093	2561	3303	4479	5756	7033	10226	13419	16612
			max.	17256	34286	51317	85370	119441	153499	187556	272699	357856	443017
DY400	—	—	min.	2790	3933	4812	7020	9821	12622	15422	22424	29426	36427
			max.	28378	56385	84391	140405	196418	252432	308445	448479	588513	728547

(1) Listed flow rate is at standard conditions STP (0°C, 1atm).

(2) Listed gauge pressure is at process temperature of 0°C.

(3) Maximum flow rate is the lower of 80m/s.

(4) Minimum flow rate: (value) is the lower limit of the accuracy range.

Table 10 Range of Measurable Saturated Steam Flow Rate at Selected Process Pressures

Model Code			Flow Rate Limits	Minimum and Maximum Measurable Flow Rate in kg/h									
				0.1 MPa	0.2 MPa	0.4 MPa	0.6 MPa	0.8 MPa	1 MPa	1.5 MPa	2 MPa	2.5 MPa	3 MPa
DY015	DY025 /R1	DY040 /R2	min.	5.8(10.7)	7.0(11.1)	8.8(11.6)	10.4(12.1)	11.6(12.3)	12.8	15.3	19.1	23.6	28.1
			max.	55.8	80	129	177	225	272	390	508	628	748
DY025	DY040 /R1	DY050 /R2	min.	13.4(18.9)	16.2(20.0)	20.5	24.1	27.1	30	36	41	49	58
			max.	169.7	247.7	400	548	696	843	1209	1575	1945	2318
DY040	DY050 /R1	DY080 /R2	min.	26.5(29.2)	32	40.6	47.7	53.8	59	72	93	116	138
			max.	405	591	954	1310	1662	2012	2884	3759	4640	5532
DY050	DY080 /R1	DY100 /R2	min.	44.0	53	67.3	79	89	98	119	156	192	229
			max.	671	979	1580	2170	2753	3333	4778	6228	7688	9166
DY080	DY100 /R1	DY150 /R2	min.	84.9	103	130	152	171	189	231	300	371	442
			max.	1295	1891	3050	4188	5314	6435	9224	12024	14842	17694
DY100	DY150 /R1	DY200 /R2	min.	148	179	227	267	300	330	402	524	647	772
			max.	2261	3300	5326	7310	9276	11232	16102	20986	25907	30883
DY150	DY200 /R1	—	min.	324	392	498	600	761	922	1322	1723	2127	2536
			max.	4950	7226	11661	16010	20315	24595	35258	45953	56729	67624
DY200	—	—	min.	697	841	1068	1252	1410	1649	2364	3081	3803	4534
			max.	8851	12918	20850	28627	36325	43976	63043	82165	101433	120913
DY250	—	—	min.	1256	1518	1929	2260	2546	2801	3655	4764	5882	7011
			max.	13687	19977	32243	44268	56172	68005	97489	127058	156854	186978
DY300	—	—	min.	1799	2174	2762	3236	3646	4012	5235	6823	8423	10041
			max.	19602	28609	46175	63397	80445	97390	139614	181960	224633	267772
DY400	—	—	min.	3381	4086	5187	6078	6848	8002	11472	14957	18468	22003
			max.	32217	47070	75834	104152	132193	160037	229449	299131	369366	440055

(1) Maximum flow rate is the lower of 80m/s.

(2) Minimum values are determined from Table 7. The values in parenthesis show the minimum linear flow rates (Re = 20,000 or 40,000) when they are higher than the minimum measurable flow rate.

■ Reference

Table 11 Inner Diameter and Nominal value

Model Code			Inner Diameter mm	Nominal K-Factor Pulse/L	Nominal Pulse Rate	
					Hz / m/s	Hz / m ³ /h
DY015	DY025 /R1	DY040 /R2	14.6	376	62.7	104
DY025	DY040 /R1	DY050 /R2	25.7	68.6	35.5	19.1
DY040	DY050 /R1	DY080 /R2	39.7	18.7	23.1	5.19
DY050	DY080 /R1	DY100 /R2	51.1	8.95	18.3	2.49
DY080	DY100 /R1	DY150 /R2	71.0	3.33	13.2	0.925
DY100	DY150 /R1	DY200 /R2	93.8	1.43	9.88	0.397
DY150	DY200 /R1	—	138.8	0.441	6.67	0.123
DY200	—	—	185.6	0.185	5.00	0.0514
DY250	—	—	230.8	0.0966	4.04	0.0268
DY300	—	—	276.2	0.0563	3.37	0.0156
DY400	—	—	354.2	0.0265	2.61	0.00736

■ Pressure Loss

Calculation of pressure loss for standard type

obtained from the following equations.

$$\Delta P = 108 \times 10^{-5} \times \rho_f \times v^2 \dots\dots\dots (1)$$

or

$$\Delta P = 135 \times \rho_f \times \frac{Q_f^2}{D^4} \dots\dots\dots (2)$$

where,

- ΔP: Pressure loss (kPa)
- ρ_f: Density at operating condition (kg/m³)
- v: Flow velocity (m/s)
- Q_f: Actual flow rate (m³/h)
- D: Inner diameter of digital YEW FLO (mm)

(Example)

DY050, hot water: 80°C, flowrate: 30 m³/h
 1. Since the density of water at 80°C is 972 kg/m³, substitute this value in equation (2):

$$\Delta P = 135 \times 972 \times 30^2 / 51.1^4 = 17.3 \text{ kPa}$$

2. Obtain the pressure loss using equation (1). The flow velocity when the flow rate is 30 m³/h is given by:

$$v = 354 \times Q_f / D^2 = \frac{354 \times 30}{51.1^2} = 4.07 \text{ m/s}$$

Therefore, substitute this value in equation (1):

$$\Delta P = 108 \times 10^{-5} \times 972 \times 4.07^2 = 17.3 \text{ kPa}$$

Calculation of pressure loss for reduced bore type (Option code: /R1)

obtained from the following equations.

$$\Delta P = 124 \times 10^{-5} \times \rho_f \times v^2 \dots\dots\dots (3)$$

or

$$\Delta P = 155 \times \rho_f \times Q_f^2 / D^4 \dots\dots\dots (4)$$

(Example)

DY040/R1, hot water: 50 °C, flowrate: 10 m³/h
 1. Since the density of water at 50 °C is 992 kg/m³, substitute this value in equation (4):

$$\Delta P = 155 \times 992 \times 10^2 / 25.7^4 = 35.3 \text{ kPa}$$

2. Obtain by using equation (3). The flow velocity when the flow rate is 10 m³/h is given by:

$$v = 354 \times Q_f / D^2 = 354 \times 10 / 25.7^2 = 5.4 \text{ m/s}$$

Therefore, substitute this value in equation (3):

$$\Delta P = 124 \times 10^{-5} \times 992 \times 5.4^2 = 35.3 \text{ kPa}$$

Calculation of pressure loss for reduced bore type (Option code: /R2)

obtained from the following equations.

$$\Delta P = 138 \times 10^{-5} \times \rho_f \times v^2 \dots\dots\dots (5)$$

or

$$\Delta P = 173 \times \rho_f \times \frac{Q_f^2}{D^4} \dots\dots\dots (6)$$

(Example)

DY050-/R2, hot water: 50 °C, flowrate: 15 m³/h
 1. Since the density of water at 50 °C is 992 kg/m³, substitute this value in equation (6):

$$\Delta P = 173 \times 992 \times 15^2 / 25.7^4 = 88.5 \text{ kPa}$$

2. Obtain by using equation (5). The flow velocity when the flow rate is 15m³/h is given by:

$$v = 354 \times Q_f / D^2 = \frac{354 \times 15}{25.7^2} = 8.0 \text{ m/s}$$

Therefore, substitute this value in equation (5):

$$\Delta P = 138 \times 10^{-5} \times 992 \times 8.0^2 = 88.5 \text{ kPa}$$

■ Cavitation

(Minimum Back Pressure, Liquid service only):

Cavitation occurs when the flow line pressure is low and flow velocity is high during fluid measurement, preventing correct measurement of flow rate. The optimum line pressure can be obtained from the following equation.

$$P = 2.7 \times \Delta P + 1.3 \times P_o \dots\dots\dots (7)$$

Where,

P: Line pressure, 2 to 7 times as large as internal diameter on downstream of flowmeter body surface. (kPa absolute).

ΔP: Pressure loss (kPa). Refer to the item above.

P_o: Saturation liquid vapor pressure at operating temperature (kPa absolute).

(Example) Confirmation of presence of cavitation

Suppose that the line pressure is 120 kPa abs and the flow rate scale is 0 to 30 m³/h. It is only necessary to confirm the pressure at the maximum flow rate ; therefore, the saturated steam pressure of water at 80°C is as follows from the table of saturated steam pressures:

$$P_o = 47.4 \text{ kPa abs}$$

Therefore, substitute this value in equation (7):

$$P = 2.7 \times 17.3 + 1.3 \times 47.4 = 108.3 \text{ kPa abs}$$

Since the operating pressure of 120 kPa abs is higher than 108.3 kPa abs, no cavitation occurs.

■ OPTION SPECIFICATIONS (FOR EXPLOSION PROTECTED TYPE)

* Refer to "Contact rating" for the maximum current value of Pulse Circuit.

Item	Specification	Code
TIIS Certification	<p>TIIS Flameproof Approval (Note 1) Flameproof Ex d IIC T6 Certified by TIIS. (TIIS is the abbreviation of Technology Institution of Industrial Safety.) Amb. Temp: -20 to 60°C Electrical connection: JIS G1/2 female</p>	JF3
Factory Mutual (FM)	<p>FM Explosion proof Approval Applicable Standard: FM3600, FM3611, FM3615, FM3810, ANSI/NEMA 250 Type of Protection: Explosion proof for Class I, Division 1, Groups A, B, C and D; Dust-ignitionproof Class II/III, Division 1, Groups E, F, and G. "SEAL ALL CONDUITS WITHIN 18 INCHES." "WHEN INSTALLED IN DIV.2, SEALS NOT REQUIRED." Enclosure Rating: Type 4X Temperature Code: T6 Ambient Temperature: -29 to 60°C (Integral Type Vortex Flowmeter and Remote Type Vortex Flow Detector) -40 to 60°C (Remote Type Vortex Flow Converter) Ambient Humidity: 0 to 100%RH (No condensation) Coating of Enclosure: Epoxy resin coating or Polyurethane resin coating. Electrical Connection: ANSI 1/2NPT female</p>	FF1
	<p>FM Intrinsically safe Approval (Note 2) Applicable Standard: FM3600, FM3610, FM3611, FM3810, NEMA-250, ANSI/ISA-60079-0, ANSI/ISA 60079-11 Type of Protection: Intrinsically safe: Class I, Division 1, Groups A, B, C and D, T4 Class II, Division 1, Groups E, F and G, T4 Class III, Division 1, T4 Class I, Zone 0, AEx ia IIC T4 Nonincendive: Class I, Division 2, Groups A, B, C and D, T4 Class II, Division 2, Groups F and G, T4 Class III, Division 1, T4 Ambient Temperature: -29 to +60°C (Integral Type Vortex Flowmeter) -29 to +80°C (Remote Type Vortex Flow Detector) -40 to +60°C (Remote Type Vortex Flow Converter) Ambient Humidity: 0 to 100% RH (No condensation) Indoors and Outdoors: Type 4X Electrical Parameter: Vmax=30Vdc, Imax=165mAdc, Pi=0.9W, Ci=12nF, Li=0.15mH Electrical Connection: ANSI 1/2NPT female</p>	FS1
ATEX	<p>ATEX Flameproof Approval (Note 3) Applicable Standard: EN 60079-0, EN 60079-1 Type of Protection: II2 G Ex d IIC T6...1 Gb (Integral Type Vortex Flowmeter and Remote Type Vortex Flow Detector) II2 G Ex d IIC T6 Gb (Remote Type Vortex Flow Converter) Groups: II, Category: 2 G Temperature Class: T6...T1 (Integral Type Vortex Flowmeter and Remote Type Vortex Flow Detector) T6 (Remote Type Vortex Flow Converter) Process Temp.: T6 (-29 to 80°C), T5 (-29 to 100°C), T4 (-29 to 135°C), T3 (-29 to 200°C), T2 (-29 to 300°C) T1 (-29 to 450°C) (Use /HT version above 250°C), Ambient temperature: -29 to 60°C (Integral Type Vortex Flowmeter and Remote Type Vortex Flow Detector) -40 to 60°C (Remote Type Vortex Flow Converter without indicator) -30 to 60°C (Remote Type Vortex Flow Converter with indicator) Ambient Humidity: 0 to 100%RH (No condensation) Electrical Connection: ANSI 1/2NPT female, ISO M20 × 1.5 female</p>	KF2
	<p>ATEX Intrinsically Sare (Note2) Applicable Standard : EN 60079-0, EN60079-11, EN 60079-26 Type of protection: Ex ia IIC T4...T1Ga (Integral Type Vortex Flowmeter) Ex ia IIC T6...T1 Ga (Remote Type Vortex Flow Detector) Ex ia IIC T4 Ga (Remote Type Vortex Flow Converter) Groups/Category: II 1 G Temperature Class: T4...T1(Integral Type Vortex Flowmeter) T6...T1(Remote Type Vortex Flow Detector) T4 (Remote Type Vortex Flow Converter) Ambient temperature: -29 to +60°C (Integral Type Vortex Flowmeter) -40 to +80[79]°C (Remote Type Vortex Flow Detector) (Option /LT below -29°C, [] for Option /MV at T6) -40 to +80°C (Remote Type Vortex Flow Converter without indicator): -30 to +80°C (Remote Type Vortex Flow Converter with indicator): Ambient Humidity: 5 to 100%RH (No condensation) Process temperature: T6: -196 to 84[79]°C, T5: -196 to 100°C, T4: -196 to 135°C, T3: -196 to 199°C, T2: -196 to 299[289]°C, T1: -196 to 449[439]°C (Option /HT above 250°C and Option /LT below -29°C, [] : Option /MV) Signal/Supply (Terminals SUPPLY + and -) and Pulse (Terminals PULSE + and -) Circuit: Ui = 30 V, Ii = 300 mA, Pi = 0.9 W (linear source), Ci = 14 nF, Li = 0 mH Electrical connection: ANSI 1/2 NPT female, ISO M20 × 1.5 female</p>	KS2

(Note 1) The flameproof packing adapter /G11 or /G12 is necessary except the electrical conduit work. In case the ambient temperature exceeds 50°C, use heat resistant cables with maximum allowable temperature of 70°C or above.

(Note 2) For intrinsically safe approval, use the barrier certified by the testing laboratories (BARD-400 is not applicable).

(Note 3) Cryogenic Version /LT is not available.

Item	Specification	Code
Canadian Standards Association (CSA)	<p>CSA Explosion proof Approval Applicable Standard: C22.1-98, C22.2 No.0, C22.2 No.0.4, C22.2 No.0.5, C22.2 No.25, C22.2 No.30, C22.2 No.94, C22.2 No.142, C22.2, No.61010-1, ANSI/ISA-12.27.01 Type of Protection: explosion-proof for Class I, Groups B, C and D; Class II, Groups E, F, and G; Class III. For Class I, Division 2 locations- "FACTORY SEALED, CONDUIT SEAL NOT REQUIRED" Temperature Class: T6...T1 (Integral Type Vortex Flowmeter and Remote Type Vortex Flow Detector) T6 (Remote Type Vortex Flow Converter) Amb. Temp.: -29 to +60°C (Integral Type Vortex Flowmeter and Remote Type Vortex Flow Detector) -40 to +60°C (Remote Type Vortex Flow Converter) Process temp.: T6;85°C, T5;100°C, T4;135°C, T3;200°C, T2;300°C, T1; 450°C Enclosure: Type 4X Coating of Enclosure: Epoxy resin coating or Polyurethane resin coating. Electrical Connection: ANSI 1/2 NPT female (Special)</p>	CF1
	<p>CSA Explosion proof Approval · The approval specification is the same with /CF1. · Process Sealing Certification Dual Seal Certified by CSA to the requirement of ANSI/ISA 12.27.01 No additional sealing required</p>	CF11
	<p>CSA Intrinsically safe Approval (Note 2) Applicable Standard: C22.2 No. 0.4, C22.2 No. 157, C22.2 No. 213, C22.2 No. 1010.1, CAN/CSA-E60079-0, CAN/CSA-E60079-11, CAN/CSA-E60079-15 and ANSI/ISA 12.27.01 Type of Protection: Ex ia IIC T4...T1 and Ex nC IIC T4...T1 (Integral Type Flowmeter and Remote Type Flowmeter) Ex ia IIC T4 and Ex nC IIC T4 (Remote Type Converter) Process Temp.: T4;135°C, T3;200°C, T2;300°C, T1;450°C (Integral Type Vortex Flowmeter and Remote Type Vortex Flow Detector) Amb. Temp.: -40 to +60°C (Integral Type Vortex Flowmeter, Remote Type Vortex Flow Detector and Remote Type Vortex Flow Converter) Amb. Hum.: 0 to 100%RH (No condensation) Degree of Protection of Enclosure: IP67 Electrical Parameter: Ui=30Vdc, Ii=165mAdc, Pi=0.9W, Ci=12nF, Li=0.15mH. Electrical Connection: ANSI 1/2 NPT female</p> <p>Type of Protection: Intrinsically Safe for Class I, II, III, DIV.1, Groups A, B, C, D, E, F and G Non-incendive for Class I, II, DIV.2, Groups A, B, C, D, E, F and G, ClassIII, DIV.1. Temperature Code: T4...T1(Integral Type Vortex Flowmeter and Remote Type Vortex Flow Detector) T4(Remote Type Vortex Flow Converter) Process Temp.: T4;135°C, T3; 200°C, T2; 300°C, T1; 450°C (Integral Type Vortex Flowmeter and Remote Type Vortex Flow Detector) Amb. Temp.: -40 to +60°C (Integral Type Vortex Flowmeter, Remote Type Vortex Flow Detector and Remote Type Vortex Flow Converter) Amb. Hum.: 0 to 100%RH (No condensation) Enclosure: Type 4X Electrical Parameter: Vmax =30Vdc, I max =165mAdc, Pmax = 0.9W, Ci =12nF, Li = 0.15mH. Electrical Connection: ANSI 1/2 NPT female</p>	CS1
	<p>CSA Intrinsically safe Approval · The approval specification is the same with /CS1. · Process Sealing Certification Dual Seal Certified by CSA to the requirement of ANSI/ISA 12.27.01 No additional sealing required</p>	CS11
IECEX	<p>IECEX Flameproof Approval (Note 1) Applicable Standard: IEC60079-0, IEC60079-1 Type of Protection: Ex d IIC T6...T1 Gb (Integral Type Vortex Flowmeter and Remote Type Vortex Flow Detector) Ex d IIC T6 Gb (Remote Type Vortex Flow Converter) Temperature Class: T6...T1 (Integral Type Vortex Flowmeter and Remote Type Vortex Flow Detector) T6 (Remote Type Vortex Flow Converter) Process Temp.: T6(-29 to 80°C), T5(-29 to 100°C), T4(-29 to 135°C), T3(-29 to 200°C), T2(-29 to 300°C), T1(-29 to 450°C) (Use /HT version above 250°C) Ambient temperature: -29 to 60°C (Integral Type Vortex Flowmeter and Remote Type Vortex Flow Detector) -40 to 60°C (Remote Type Vortex Flow Converter without indicator) -30 to 80°C (Remote Type Vortex Flow Converter with indicator) Ambient Humidity: 0 to 100%RH Electrical Connection: ANSI 1/2NPT female, ISO M20 × 1.5 female</p>	SF2
	<p>IECEX Intrinsically Safe (Note2) Applicable Standard : IEC 60079-0, IEC60079-11, IEC 60079-26 Type of protection: Ex ia IIC T4...T1Ga (Integral Type Vortex Flowmeter) Ex ia IIC T6...T1 Ga (Remote Type Vortex Flow Detector) Ex ia IIC T4 Ga (Remote Type Vortex Flow Converter) Temperature Class: T4...T1(Integral Type Vortex Flowmeter) T6...T1(Remote Type Vortex Flow Detector) T4 (Remote Type Vortex Flow Converter) Ambient temperature: -29 to +60°C (Integral Type Vortex Flowmeter) -40 to +80[79]°C (Remote Type Vortex Flow Detector) (Option /LT below -29°C, [] for Option /MV at T6) -40 to +80°C (Remote Type Vortex Flow Converter without indicator): -30 to +80°C (Remote Type Vortex Flow Converter with indicator): Ambient Humidity: 5 to 100%RH (No condensation) Process temperature: T6: -196 to 84[79]°C, T5: -196 to 100°C, T4: -196 to 135°C, T3: -196 to 199°C, T2: -196 to 299[289]°C, T1: -196 to 449[439]°C (Option /HT above 250°C and Option /LT below -29°C, [] : Option /MV) Signal/Supply (Terminals SUPPLY + and -) and Pulse (Terminals PULSE + and -) Circuit: Ui = 30 V, Ii = 300 mA, Pi = 0.9 W (linear source), Ci = 14 nF, Li = 0 mH Electrical connection: ANSI 1/2 NPT female, ISO M20 × 1.5 female</p>	SS2

(Note 1) Cryogenic Version /LT is not available.

(Note 2) For intrinsically safe approval, use the barrier certified by the testing laboratories (BARD-400 is not applicable).

REMARKS ON INSTALLATION

Piping support

Typical vibration immunity level is 1G for normal piping condition. Piping support should be fixed in case of over 1G vibration level.

Installation direction

If a pipe is always filled with liquids, the pipe can be installed vertically or at inclined angle.

Adjacent pipes

The process pipeline inner diameter should be larger than the digitalYEWFLOW inner diameter. Use the following adjacent pipe.

Model Code	Adjacent Pipe
DY015 up to DY050 DY025/R1 up to DY080/R1 DY040/R2 up to DY100/R2	Sch40 or larger inner diameter than Sch40
DY080 up to DY400 DY100/R1 up to DY200/R1 DY150/R2 up to DY200/R2	Sch80 or larger inner diameter than Sch80

Straight pipe length and recommendations (1)

D: Nominal diameter (mm)

Description	Figure
<p>Reducer pipe: Ensure the upstream straight pipe length to be 5D or more, and the downstream straight pipe length to be 5D or more for per reducer pipe.</p>	
<p>Expander pipe: Ensure the upstream straight pipe length to be 10D or more, and the downstream straight pipe length to be 5D or more for per expander pipe.</p>	
<p>Bent pipe and straight pipe length:</p> <ol style="list-style-type: none"> Single bent pipe Double bent pipe; coplanar Double bent pipe; non coplanar 	
<p>Valve position and straight pipe length:</p> <p>■ Install the valve on the downstream side of the flowmeter. The upstream straight pipe length dependent on the element located on the upstream such as reducer/expander, bent and etc., refer to description as above. Keep 5D or more for downstream straight pipe length.</p> <p>■ In case the valve has to be installed on the upstream of the flowmeter, ensure the upstream straight pipe length to be 20D or more, and the downstream straight pipe length be 5D or more.</p>	

● **Straight pipe length and recommendations (2)**

D: Nominal diameter (mm)

Description	Figure
<p>Fluid vibration: For a gas line which uses a position-type or roots-type blower compressor or a high-pressure liquid line (about 1MPa or more) which uses piston-type or plunger-type pump, fluid vibrations may be produced. In these case, install valve on the upstream side of digitalYEWFLO. For inevitable fluid vibration, put a vibration damping device such as throttling plate or expansion section in the upstream side of digitalYEWFLO.</p>	
<p>Piston-type or plunger pump: Install the accumulator on the upstream side of digitalYEWFLO to reduce fluid vibrations.</p>	
<p>Valve position (T-type piping exist): When pulsation causes by a T-type piping exist, install the valve on the upstream of the flowmeter. Example: As shown in the figure, when the valve V1 is turned off, the fluid flow through B as to meter A the flow is zero. But due to the pulsating pressure is detected, the meter is zero point become fluctuating. To avoid this, change the valve V1 location to V1'. Note: In case of the Reduced Bore Type, moisture may be remained upstream of the flowmeter. Drain it appropriately.</p>	
<p>Pressure and Temperature Taps: Pressure tap outlet: install this tap between 2D and 7D on the downstream side of a flowmeter. Temperature tap outlet: install this on the downstream side 1D to 2D away from a pressure tap.</p>	
<p>Mounting Gasket: Avoid mounting gaskets which protrude into the pipe line. This may cause inaccurate readings. Use the gaskets with bolt holes, even if digitalYEWFLO is the wafer type. When using a spiral gasket (without bolt holes), confirm the size with the gasket -manufacturer, as standard items may not be used for certain flange ratings.</p>	

● Straight pipe length and recommendations (3)

Description	Figure
<p>Heat-Insulation: When an integral-type flowmeter or a remote type detector is installed and the pipe carrying high-temperature fluids is heat-insulated, do not wrap adiabatic materials around the installation the bracket (DY015 to DY100) or the nozzle (DY150 to DY400) of the converter.</p>	
<p>Flushing of the pipe line: Flush and clean scale, incrustation and sludge on the inside of pipe for newly installed pipe line and repaired pipe line before the operation. For flushing, the flow should flow through bypass-piping to avoid damaging the flowmeter. If there is no bypass-piping, install short pipe instead of the flowmeter.</p>	

● The wiring example for the analog and pulse and status, alarm output.

Connection	Description
<p>Analog Output In this case, Communication is possible (up to a distance of 2km when a CEV cable is used.)</p>	<p>digitalYEWFLOW Electrical Terminal</p>
<p>Pulse Output In this case, No communication is possible.</p>	<p>digitalYEWFLOW Electrical Terminal</p> <p>Shielded Cable</p> <p>Use the Three-wire shielded cable.</p> <p>This supply voltage requires a power source with a maximum output current of no less than $E/R+25mA$.</p>
<p>Status Output Alarm Output In this case, No communication is possible.</p>	<p>digitalYEWFLOW Electrical Terminal</p> <p>Shielded Cable</p> <p>Use the Three-wire shielded cable.</p> <p>External Power supply 30V DC, 120mA max (Contact Rating)</p> <p>AC power supply</p>

*1: To avoid the influence of external noise, use an electric counter which fits to the pulse frequency.
*2: Resistor is not necessary in case of an electric counter which can receive contact pulse signal directly.

● The wiring example for the the simultaneous analog and pulse output, the calculation formula of the range of load resistance R for the pulse output.

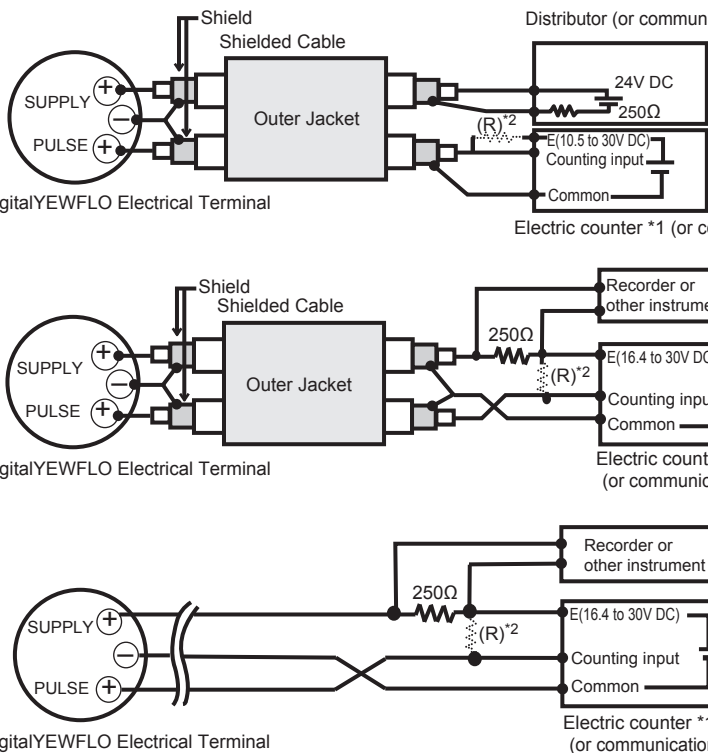
Connection	Description
<p>Simultaneous Analog -Pulse Output ^{*3}</p> <p>Example 1 In this case, Communication is possible (up to a distance of 2km when a CEV cable is used).</p> <p>Example 2 In this case, Communication is possible (up to a distance of 200m when a CEV cable is used) and R = 1kΩ).</p> <p>Example 3 In this case, No communication is possible (when shielded cable is not used).</p>	<p>When analog and pulse output are used, the length of communication line is subjected to wiring conditions. Refer to example 1 to 3. If the communication carries out from amplifier, no need to consider wiring conditions.</p>  <p>digitalYEWFLO Electrical Terminal</p> <p>Distributor (or communication medium)</p> <p>For the shielded cables in this example of flowmeter installation, use two-wire separately shielded cables. ^{*4}</p> <p>This supply voltage requires a power source with a maximum output current of no less than E/R.</p> <p>24V DC</p> <p>250Ω</p> <p>E(10.5 to 30V DC)</p> <p>Counting input</p> <p>Common</p> <p>Electric counter *1 (or communication medium)</p> <p>Recorder or other instrument</p> <p>250Ω</p> <p>E(16.4 to 30V DC)</p> <p>Counting input</p> <p>Common</p> <p>Electric counter *1 (or communication medium)</p> <p>Recorder or other instrument</p> <p>250Ω</p> <p>E(16.4 to 30V DC)</p> <p>Counting input</p> <p>Common</p> <p>Electric counter *1 (or communication medium)</p> <p>This supply voltage requires a power source with a maximum output current of no less than E/R+25mA.</p>
<p>The range of load resistance R for the pulse output.</p>	<p>The load resistance should be selected by calculation as shown below.</p> $\frac{E (V) ^5}{120} \leq R (k\Omega) \leq \frac{0.1}{C (\mu F) \times f (kHz)}$ <p>Example of CEV cable capacitance $\approx 0.1\mu F/km$</p> $P (mW) = \frac{E^2 (V)}{R (k\Omega)}$ <p>Where E = Supply voltage (V) f = Frequency of pulse output (kHz) R = Value of load resistance (kΩ) C = Cable capacitance (μF) P = Power ratio of the load resistance (mW)</p>

*1: To avoid the influence of external noise, use an electric counter which fits to the pulse frequency.
 *2: Resistor is not necessary in case of an electric counter which can receive contact pulse signal directly.
 *3: When using analog and pulse output simultaneously, the HART communication may be influenced by noise comparing analog output only.
 *4: Signal Cable for ADMAG AXF, AXFC-0 (No Termination) is available.

*5: $\frac{E (V)}{80}$ for /KS2 and /SS2

EXTERNAL DIMENSIONS

Wafer type (DY015 to DY100)

Unit : mm
(approx. inch)

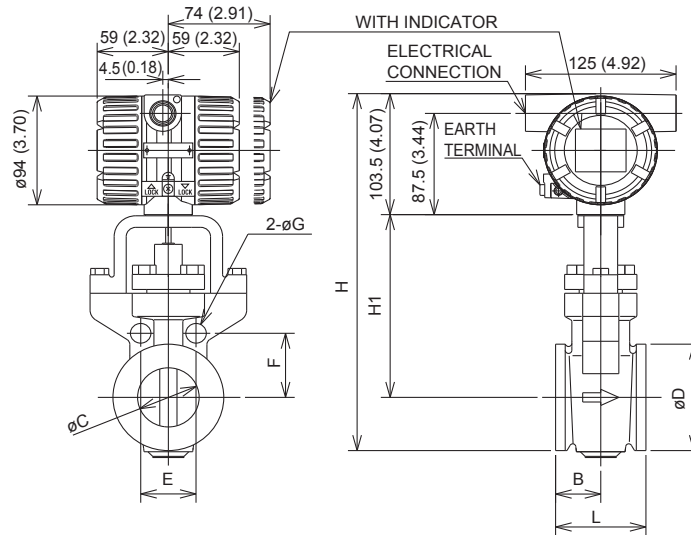

TYPE	INTEGRAL/REMOTE																				
MODEL CODE	DY015					DY025					DY040										
PROCESS CONNECTION	AJ1	AJ2	AJ4	AA1	AA2	AA4	AD1 to AD4	AJ1	AJ2	AJ4	AA1	AA2	AA4	AD1 to AD4	AJ1	AJ2	AJ4	AA1	AA2	AA4	AD1 to AD4
L	70 (2.76)					70 (2.76)					70 (2.76)										
B	35 (1.38)					35 (1.38)					35 (1.38)										
C	14.6 (0.57)					25.7 (1.01)					39.7 (1.56)										
D	35.1 (1.38)					50.8 (2.00)					73 (2.87)										
H	248 (9.76)					258 (10.16)					276 (10.87)										
H1	127 (5.00)					129 (5.08)					136 (5.35)										
E	49.5 (1.95)	49.5 (1.95)	56.6 (2.23)	42.7 (1.68)	47.1 (1.85)	47.1 (1.85)	46 (1.81)	63.6 (2.50)	63.6 (2.50)	67.2 (2.65)	56 (2.21)	62.9 (2.48)	62.9 (2.48)	60.1 (2.37)	74.2 (2.92)	74.2 (2.92)	84.9 (3.34)	69.7 (2.74)	80.8 (3.18)	80.8 (3.18)	77.8 (3.06)
F	24.7 (0.97)	24.7 (0.97)	28.3 (1.11)	21.4 (0.84)	23.5 (0.93)	23.5 (0.93)	23 (0.91)	31.8 (1.25)	31.8 (1.25)	33.6 (1.32)	28 (1.10)	31.4 (1.24)	31.4 (1.24)	30.1 (1.19)	37.1 (1.46)	37.1 (1.46)	42.4 (1.67)	34.8 (1.37)	40.4 (1.59)	40.4 (1.59)	38.9 (1.53)
G	13 (0.51)	13 (0.51)	17 (0.67)	14 (0.55)	14 (0.55)	14 (0.55)	13 (0.51)	17 (0.67)	17 (0.67)	17 (0.67)	14 (0.55)	17 (0.67)	17 (0.67)	13 (0.51)	17 (0.67)	17 (0.67)	21 (0.83)	14 (0.55)	20 (0.79)	20 (0.79)	17 (0.67)
WEIGHT kg (lb)	2.8 (6.2)					3.7 (8.2)					4.3 (9.5)										

TYPE	INTEGRAL/REMOTE																						
MODEL CODE	DY050					DY080					DY100												
PROCESS CONNECTION	AJ1	AJ2	AJ4	AA1	AA2	AA4	AD1 to AD4	AJ1	AJ2	AJ4	AA1	AA2	AA4	AD1 AD2	AD3 AD4	AJ1	AJ2	AJ4	AA1	AA2	AA4	AD1 AD2	AD3 AD4
L	75 (2.95)					100 (3.94)					120 (4.72)												
B	37.5 (1.48)					40 (1.57)					50 (1.97)												
C	51.1 (2.01)					71 (2.80)					93.8 (3.69)												
D	92 (3.62)					127 (5.00)					157.2 (6.19)												
H	307.5 (12.11)					342 (13.47)					372 (14.65)												
H1	158 (6.22)					175 (6.89)					190 (7.48)												
E	(Note 3)	45.9 (1.81)	49.8 (1.96)	(Note 3)	48.6 (1.91)	48.6 (1.91)	(Note 3)	57.4 (2.26)	61.2 (2.41)	65.1 (2.56)	(Note 3)	64.4 (2.54)	64.4 (2.54)	61.2 (2.41)	61.2 (2.41)	67 (2.64)	70.8 (2.79)	78.5 (3.09)	72.9 (2.87)	76.6 (3.02)	82.6 (3.25)	68.9 (2.71)	72.7 (2.86)
F	(Note 3)	55.4 (2.18)	60.1 (2.36)	(Note 3)	58.7 (2.31)	58.7 (2.31)	(Note 3)	69.3 (2.73)	73.9 (2.91)	78.5 (3.09)	(Note 3)	77.7 (3.06)	77.7 (3.06)	73.9 (2.91)	73.9 (2.91)	80.8 (3.18)	85.5 (3.37)	94.7 (3.73)	88 (3.46)	92.5 (3.64)	99.7 (3.93)	83.1 (3.27)	87.8 (3.46)
G	(Note 3)	17 (0.67)	17 (0.67)	(Note 3)	17 (0.67)	17 (0.67)	(Note 3)	17 (0.67)	21 (0.83)	21 (0.83)	(Note 3)	20 (0.79)	20 (0.79)	17 (0.67)	17 (0.67)	17 (0.67)	21 (0.83)	23 (0.91)	17 (0.67)	20 (0.79)	23 (0.91)	17 (0.67)	21 (0.83)
WEIGHT kg (lb)	6.0 (13.2)					9.4 (20.7)					12.8 (28.2)												

(Note 1) Integral weight is the same as Remote.

(Note 2) In case of with Indicator, add 0.2kg.

(Note 3) The holes are not provided.

(Note 4) The flow direction is opposite (right to left when facing onto indicator) in case of code/CRC.

■ Flange type (DY015 to DY100)

Unit : mm
(approx. inch)

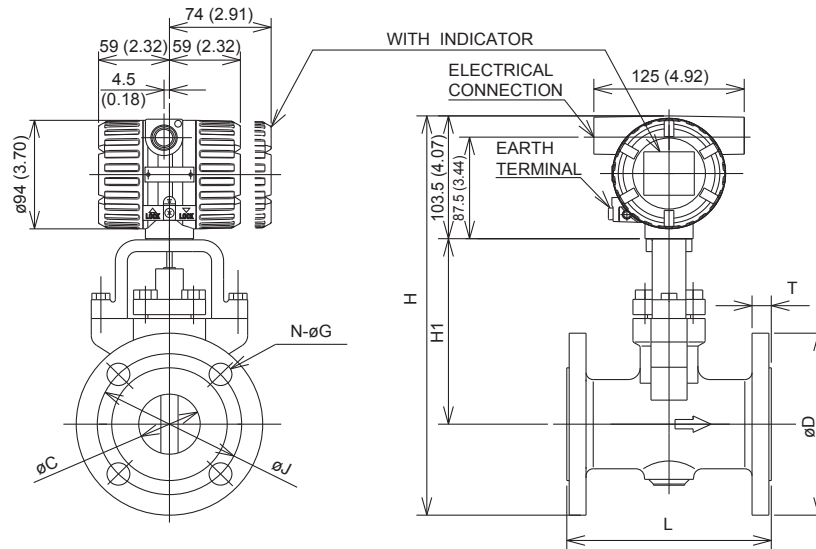

TYPE	INTEGRAL/REMOTE																			
	DY015								DY025											
MODEL CODE																				
PROCESS CONNECTION	BJ1	BJ2	BJ4	BA1 BS1	BA2 BS2	BA4 BS4	BA5 BS5	BD1 to BD4	CA4	CA5	BJ1	BJ2	BJ4	BA1 BS1	BA2 BS2	BA4 BS4	BA5 BS5	BD1 to BD4	CA4	CA5
L	130 (5.12)								150 (5.91)											
C	14.6 (0.58)								25.7 (1.01)											
D	95 (3.74)	95 (3.74)	115 (4.53)	98.9 (3.90)	95.3 (3.75)	120.7 (4.75)	95 (3.74)	95.3 (3.75)	120.7 (4.75)	125 (4.92)	125 (4.92)	130 (5.12)	108 (4.25)	124 (4.88)	124 (4.88)	149.4 (5.88)	115 (4.53)	124 (4.88)	149.4 (5.88)	
H	278 (10.94)	278 (10.94)	288 (11.34)	275 (10.83)	278 (10.94)	278 (10.94)	291 (11.46)	278 (10.94)	278 (10.94)	295 (11.61)	295 (11.61)	297.5 (11.91)	285.5 (11.28)	294.5 (11.59)	294.5 (11.59)	307 (12.09)	290 (11.42)	294.5 (11.59)	307 (12.09)	
H1	127 (5.00)								129 (5.08)											
T	12 (0.47)	14 (0.55)	20 (0.79)	11.2 (0.44)	14.2 (0.56)	21 (0.83)	28.8 (1.13)	16 (0.63)	19.9 (0.78)	28.8 (1.13)	14 (0.55)	16 (0.63)	22 (0.87)	14.2 (0.56)	17.5 (0.69)	24 (0.94)	34.9 (1.37)	18 (0.71)	24 (0.94)	
J	70 (2.76)	70 (2.76)	80 (7.15)	60.5 (2.38)	66.5 (2.62)	66.5 (2.62)	82.6 (3.25)	65 (2.56)	66.5 (2.62)	82.6 (3.25)	90 (3.54)	90 (3.54)	95 (3.74)	79.2 (3.12)	89 (3.50)	89 (3.50)	101.6 (4.00)	85 (3.35)	89 (3.50)	
N	4								4											
G	15 (0.59)	15 (0.59)	19 (0.75)	15.7 (0.62)	15.7 (0.62)	15.7 (0.62)	22.4 (0.88)	14 (0.55)	15.7 (0.62)	22.4 (0.88)	19 (0.75)	19 (0.75)	19 (0.75)	15.7 (0.62)	19 (0.75)	19 (0.75)	25.4 (1.00)	14 (0.55)	19 (0.75)	
WEIGHT kg (lb)	4.2 (9.26)	4.3 (9.48)	5.9 (13.01)	4.1 (9.04)	4.3 (9.48)	4.6 (10.14)	6.7 (14.77)	4.2 (9.26)	4.5 (9.92)	6.8 (14.99)	6.9 (15.21)	7.1 (15.66)	8.6 (18.96)	6.6 (14.55)	7.2 (15.88)	11.1 (24.48)	6.9 (15.21)	7.9 (17.42)	11.4 (25.14)	

TYPE	INTEGRAL/REMOTE																			
	DY040								DY050											
MODEL CODE																				
PROCESS CONNECTION	BJ1	BJ2	BJ4	BA1 BS1	BA2 BS2	BA4 BS4	BA5 BS5	BD1 to BD4	CA4	CA5	BJ1	BJ2	BJ4	BA1 BS1	BA2 BS2	BA4 BS4	BA5 BS5	BD1 to BD4	CA4	CA5
L	150 (5.91)								170 (6.69)											
C	39.7 (1.56)								51.1 (2.01)											
D	140 (5.51)	140 (5.51)	160 (6.30)	127 (5.00)	155.4 (6.12)	155.4 (6.12)	177.8 (7.00)	150 (5.91)	155.4 (6.12)	177.8 (7.00)	155 (6.10)	155 (6.10)	165 (6.50)	152.4 (6.00)	165.1 (6.50)	165.1 (6.50)	215.9 (8.50)	165 (6.50)	165.1 (6.50)	
H	309.5 (12.19)	309.5 (12.19)	319.5 (12.58)	303 (11.93)	317 (12.48)	317 (12.48)	328.5 (12.93)	314.5 (12.38)	317 (12.48)	328.5 (12.93)	339 (13.35)	339 (13.35)	344 (13.54)	337.5 (13.29)	344 (13.54)	344 (13.54)	369.5 (14.55)	344 (13.54)	344 (13.54)	
H1	136 (5.35)								158 (6.22)											
T	16 (0.63)	18 (0.71)	26 (1.02)	17.5 (0.69)	20.6 (0.81)	28.8 (1.13)	38.2 (1.50)	18 (0.71)	28.8 (1.13)	38.2 (1.50)	16 (0.63)	18 (0.71)	26 (1.02)	19.1 (0.75)	22.4 (0.88)	31.8 (1.25)	44.5 (1.75)	20 (0.79)	33.3 (1.31)	
J	105 (4.13)	105 (4.13)	120 (4.72)	98.6 (3.88)	114.3 (4.50)	114.3 (4.50)	124 (4.88)	110 (4.33)	114.3 (4.50)	124 (4.88)	120 (4.72)	120 (4.72)	130 (5.12)	120.7 (4.75)	127 (5.00)	127 (5.00)	165.1 (6.50)	125 (4.92)	127 (5.00)	
N	4								4											
G	19 (0.75)	19 (0.75)	23 (0.91)	15.7 (0.62)	22.4 (0.88)	22.4 (0.88)	28.4 (1.12)	18 (0.71)	22.4 (0.88)	28.4 (1.12)	19 (0.75)	19 (0.75)	19 (0.75)	19 (0.75)	19 (0.75)	19 (0.75)	25.4 (1.00)	18 (0.71)	19 (0.75)	
WEIGHT kg (lb)	8.2 (18.08)	8.4 (18.52)	11.9 (26.24)	8.1 (17.86)	9.3 (20.51)	11.3 (24.92)	16.2 (35.72)	8.8 (19.4)	11.7 (25.8)	16.3 (35.94)	11.1 (24.48)	11.6 (25.58)	14.3 (31.53)	11.7 (25.8)	13.2 (29.11)	14.8 (32.63)	26.5 (58.43)	11.3 (24.92)	15.8 (34.84)	

TYPE	INTEGRAL/REMOTE																					
	DY080								DY100													
MODEL CODE																						
PROCESS CONNECTION	BJ1	BJ2	BJ4	BA1 BS1	BA2 BS2	BA4 BS4	BA5 BS5	BD1 to BD2	BD3 to BD4	CA4	CA5	BJ1	BJ2	BJ4	BA1 BS1	BA2 BS2	BA4 BS4	BA5 BS5	BD1 to BD2	BD3 to BD4	CA4	CA5
L	200 (7.87)								220 (8.66)													
C	71 (2.80)								93.8 (3.69)													
D	185 (7.28)	200 (7.87)	210 (8.27)	190.5 (7.50)	209.6 (8.25)	209.6 (8.25)	241.3 (9.50)	200 (7.87)	200 (7.87)	209.6 (8.25)	241.3 (9.50)	210 (8.27)	225 (8.90)	250 (9.84)	228.6 (9.00)	254 (10.00)	273 (10.75)	292.1 (11.50)	220 (8.66)	235 (9.25)		
H	371 (14.61)	378.5 (14.90)	383.5 (15.10)	374 (14.72)	383.5 (15.10)	383.5 (15.10)	399 (15.71)	378.5 (14.90)	378.5 (14.90)	383.5 (15.10)	399 (15.71)	398.5 (15.69)	406 (15.98)	418.5 (16.48)	409 (16.10)	420.5 (16.56)	430 (16.93)	439.5 (17.30)	411 (16.18)	430 (16.93)		
H1	175 (6.89)								190 (7.48)													
T	18 (0.71)	22 (0.87)	32 (1.26)	23.9 (0.94)	28.4 (1.12)	38.2 (1.50)	44.5 (1.75)	20 (0.79)	24 (0.95)	39.7 (1.56)	46 (1.81)	18 (0.71)	24 (0.95)	36 (1.42)	23.9 (0.94)	31.8 (1.25)	44.5 (1.75)	50.9 (2.00)	20 (0.79)	24 (0.95)		
J	150 (5.91)	160 (6.30)	170 (6.69)	152.4 (6.00)	168.2 (6.62)	168 (6.61)	190.5 (7.50)	160 (6.30)	160 (6.30)	170 (6.69)	180 (7.09)	175 (6.89)	185 (7.28)	205 (8.07)	190.5 (7.50)	200.2 (7.88)	216 (8.50)	235 (9.25)	180 (7.09)	190 (7.48)		
N	8								8													
G	19 (0.75)	23 (0.91)	23 (0.91)	19 (0.75)	22.4 (0.88)	22.4 (0.88)	25.4 (1.00)	18 (0.71)	18 (0.71)	22.4 (0.88)	25.4 (1.00)	19 (0.75)	23 (0.91)	25 (0.98)	19 (0.75)	22.4 (0.88)	25.4 (1.00)	31.8 (1.25)	18 (0.71)	22 (0.87)		
WEIGHT kg (lb)	17.4 (38.37)	20 (44.1)	25.4 (56.01)	20 (44.1)	23.8 (52.48)	25.4 (56.01)	35.7 (78.72)	19.4 (42.78)	20 (44.1)	27.1 (59.76)	36.3 (80.04)	22.8 (50.27)	26.8 (59.09)	38.1 (84.01)	27.4 (60.42)	35.9 (79.16)	50.8 (112.01)	55.9 (123.26)	23.2 (51.16)	27.4 (60.42)		

(Note 1) Integral weight is the same as Remote.
 (Note 2) In case of with Indicator, add 0.2kg.
 (Note 3) The flow direction is opposite (right to left when facing onto indicator) in case of code/CRC.

■ Flange type (DY150 to DY400)

Unit : mm
(approx. inch)

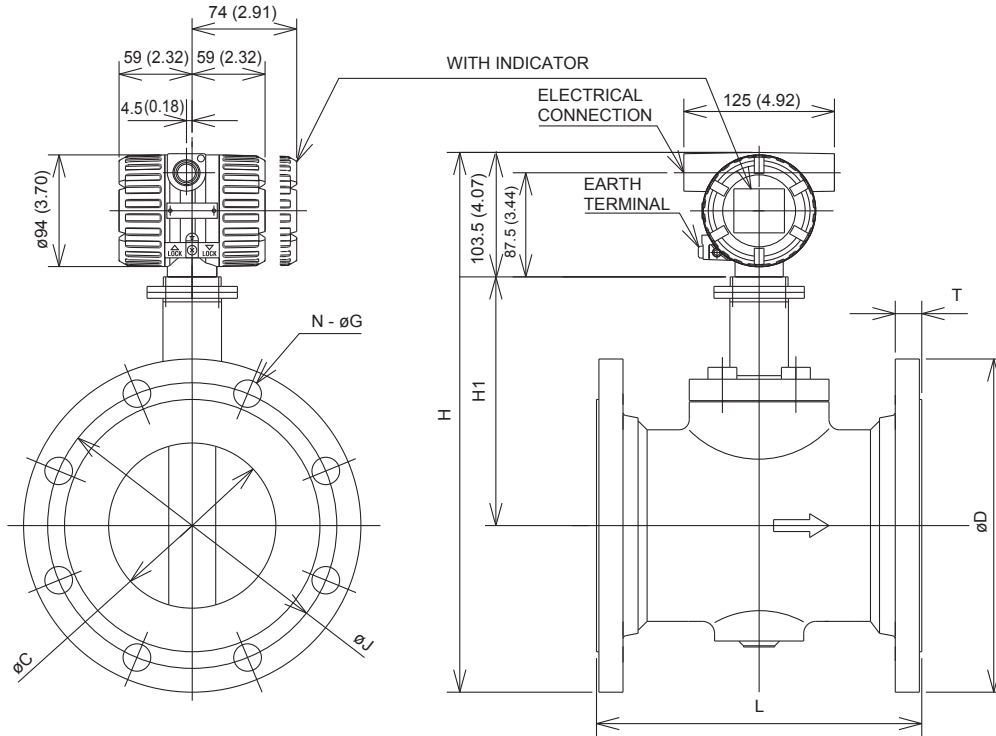

TYPE	INTEGRAL/REMOTE																							
	DY150												DY200											
MODEL CODE																								
PROCESS CONNECTION	BJ1	BJ2	BJ4	BA1 BS1	BA2 BS2	BA4 BS4	BA5 BS5	BD1 BD2	BD3 BD4	CA4	CA5	BJ1	BJ2	BA1 BS1	BA2 BS2	BA4 BS4	BA5 BS5	BD1	BD2	BD3	BD4	CA4	CA5	
L	270 (10.63)												310 (12.20)											
C	138.8 (5.46)																							
D	280 (11.02)	305 (12.01)	355 (13.98)	279.4 (11.00)	317.5 (12.50)	356 (14.02)	381 (15.00)	285 (11.22)	300 (11.81)	356 (14.02)	381 (15.00)	330 (12.99)	350 (13.78)	342.9 (13.50)	381 (15.00)	419.1 (16.50)	469.9 (18.50)	340 (13.39)	340 (13.39)	360 (14.17)	375 (14.76)	419.1 (16.50)	469.9 (18.50)	
H	453 (17.83)	465 (18.31)	490 (19.29)	452 (17.80)	471 (18.54)	491 (19.33)	503 (19.80)	455 (17.91)	463 (18.23)	491 (19.33)	503 (19.80)	510 (20.08)	520 (20.47)	516 (20.31)	535 (21.06)	554 (21.81)	579 (22.80)	515 (20.28)	515 (20.28)	525 (20.67)	532 (20.94)	554 (21.81)	579 (22.80)	
H1	460 (18.11)												472 (18.58)											
H1	209 (8.23)												241 (9.49)											
T	216 (8.50)																							
J	22 (0.87)	28 (1.10)	44 (1.73)	25.4 (1.00)	36.6 (1.44)	54.4 (2.14)	62 (2.44)	16 (0.63)	16 (0.63)	19.9 (0.78)	28.8 (1.13)	22 (0.87)	30 (1.18)	28.4 (1.12)	41.1 (1.62)	62 (2.44)	69.9 (2.75)	24 (0.95)	24 (0.95)	30 (1.18)	34 (1.34)	63.6 (2.50)	71.4 (2.81)	
N	240 (9.45)	260 (10.24)	295 (11.61)	241.3 (9.50)	269.7 (10.62)	292 (11.50)	317.5 (12.50)	65 (2.56)	65 (2.56)	66.5 (2.62)	82.6 (3.25)	290 (11.42)	305 (12.01)	298.5 (11.75)	330.2 (13.00)	349.3 (13.75)	393.7 (15.50)	295 (11.61)	295 (11.61)	310 (12.20)	320 (12.60)	348.3 (13.75)	393.7 (15.50)	
G	8 (0.31)	12 (0.47)	12 (0.47)	8 (0.31)	12 (0.47)	12 (0.47)	12 (0.47)	8 (0.31)	8 (0.31)	12 (0.47)	12 (0.47)	8 (0.31)	12 (0.47)	8 (0.31)	12 (0.47)	12 (0.47)	12 (0.47)	8 (0.31)	8 (0.31)	12 (0.47)	12 (0.47)	12 (0.47)	12 (0.47)	
WEIGHT kg (lb)	33.4 (73.65)	43.4 (95.7)	76.4 (168.46)	36.4 (80.28)	54.4 (119.95)	84.4 (186.10)	106 (233.73)	33.4 (73.65)	42.9 (94.59)	90 (198.45)	107 (235.94)	45.4 (100.11)	52.4 (115.54)	55.4 (122.16)	80.4 (177.28)	136 (299.88)	182 (401.31)	46.3 (102.09)	46.3 (102.09)	53.6 (118.19)	55.9 (123.26)	139 (306.52)	183 (403.52)	

TYPE	INTEGRAL/REMOTE											
	DY250		DY300		DY400							
MODEL CODE												
PROCESS CONNECTION	BJ1	BJ2	BA1 BS1	BA2 BS2	BJ1	BJ2	BA1 BS1	BA2 BS2	BJ1	BJ2	BA1 BS1	BA2 BS2
L	370 (14.57)				400 (15.75)				520 (20.47)			
C	230.8 (9.09)								354.2 (13.94)			
D	400 (15.75)	140 (5.51)	406.4 (16.00)	444.5 (17.50)	445 (17.52)	480 (18.90)	482.6 (19.00)	520.7 (20.50)	560 (22.05)	605 (23.82)	596.9 (23.5)	647.7 (25.5)
H	581 (22.87)	309.5 (12.19)	584 (22.99)	603 (23.74)	633 (24.92)	651 (25.63)	652 (25.67)	671 (26.42)	757.5 (29.82)	780 (30.71)	776 (30.55)	801 (31.54)
H1	277 (10.91)				307 (12.09)				374 (14.72)			
T	24 (0.94)	34 (1.34)	30.2 (1.19)	47.8 (1.88)	24 (0.94)	36 (1.42)	31.8 (1.25)	50.8 (2.00)	28 (1.10)	46 (1.81)	36.6 (1.44)	57.2 (2.25)
J	355 (13.98)	380 (14.96)	362 (14.25)	387.4 (15.25)	400 (15.75)	430 (16.93)	431.8 (17.00)	450.9 (17.75)	510 (20.08)	540 (21.26)	539.8 (21.25)	571.5 (22.5)
N	12 (0.47)	12 (0.47)	12 (0.47)	16 (0.63)	16 (0.63)	16 (0.63)	12 (0.47)	16 (0.63)	16 (0.63)	16 (0.63)	16 (0.63)	20 (0.79)
G	25 (0.98)	27 (1.06)	25.4 (1.00)	28.5 (1.12)	25 (0.98)	27 (1.06)	25.4 (1.00)	31.8 (1.25)	27 (1.06)	33 (1.30)	28.5 (1.12)	35.1 (1.38)
WEIGHT kg (lb)	78 (171.99)	100 (220.5)	90 (198.45)	125 (276.63)	100 (220.5)	128 (282.24)	140 (308.7)	178 (392.49)	265 (584.2)	308 (679)	300 (661.4)	370 (815.7)

(Note 1) Integral weight is the same as Remote.
 (Note 2) In case of with Indicator, add 0.2kg.
 (Note 3) The flow direction is opposite (right to left when facing onto indicator) in case of code/CRC.

- High Process Temperature Version (/HT): DY025/HT to DY100/HT
- Cryogenic Version (/LT): DY015/LT to DY100/LT
- Wafer type

Unit : mm
(approx. inch)

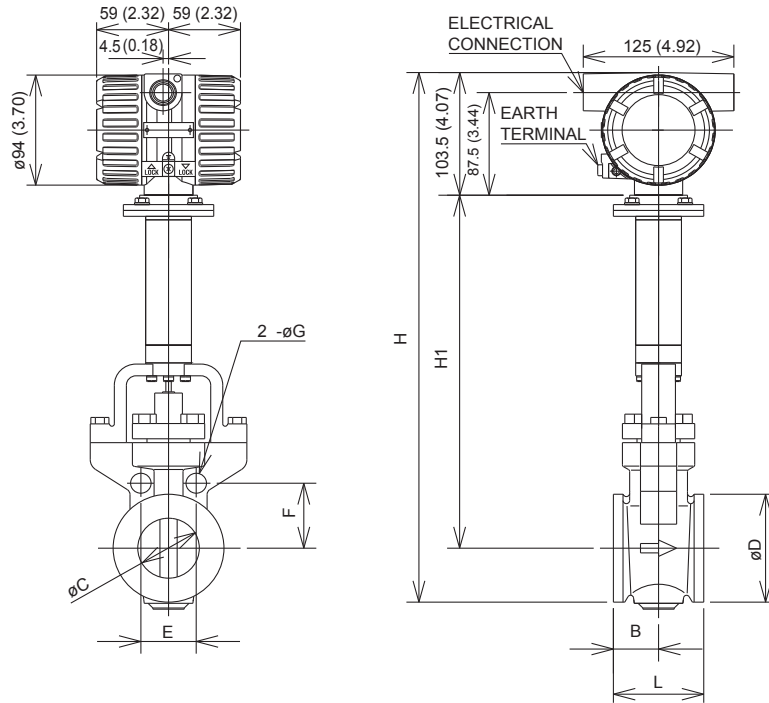

TYPE	REMOTE																				
MODEL CODE	DY015/LT						DY025/LT, DY025/HT						DY040/LT, DY040/HT								
PROCESS CONNECTION	AJ1	AJ2	AJ4	AA1	AA2	AA4	AD1 to AD4	AJ1	AJ2	AJ4	AA1	AA2	AA4	AD1 to AD4	AJ1	AJ2	AJ4	AA1	AA2	AA4	AD1 to AD4
L	70 (2.76)						70 (2.76)						70 (2.76)								
B	35 (1.38)						35 (1.38)						35 (1.38)								
C	14.6 (0.57)						25.7 (1.01)						39.7 (1.56)								
D	35.1 (1.38)						50.8 (2.00)						73 (2.87)								
H	391 (15.39)						401 (15.79)						419 (16.50)								
H1	270 (10.63)						272 (10.71)						279 (10.98)								
E	49.5 (1.95)	49.5 (1.95)	56.6 (2.23)	42.7 (1.68)	47.1 (1.85)	47.1 (1.85)	46 (1.81)	63.6 (2.50)	63.6 (2.50)	67.2 (2.65)	56 (2.20)	62.9 (2.48)	62.9 (2.48)	60.1 (2.37)	74.2 (2.92)	74.2 (2.92)	84.9 (3.34)	69.7 (2.74)	80.8 (3.18)	80.8 (3.18)	77.8 (3.06)
F	24.7 (0.97)	24.7 (0.97)	28.3 (1.11)	21.4 (0.84)	23.5 (0.93)	23.5 (0.93)	23 (0.91)	31.8 (1.25)	31.8 (1.25)	33.6 (1.32)	28 (1.10)	31.4 (1.24)	31.4 (1.24)	30.1 (1.19)	37.1 (1.46)	37.1 (1.46)	42.4 (1.67)	34.8 (1.37)	40.4 (1.59)	40.4 (1.59)	38.9 (1.53)
G	13 (0.51)	13 (0.51)	17 (0.67)	14 (0.55)	14 (0.55)	14 (0.55)	13 (0.51)	17 (0.67)	17 (0.67)	17 (0.67)	14 (0.55)	17 (0.67)	17 (0.67)	13 (0.51)	17 (0.67)	17 (0.67)	21 (0.83)	14 (0.55)	20 (0.79)	20 (0.79)	17 (0.67)
WEIGHT kg (lb)	3.2 (7.06)						4.1 (9.04)						4.7 (10.36)								

TYPE	REMOTE																						
MODEL CODE	DY050/LT, DY050/HT						DY080/LT, DY080/HT						DY100/LT, DY100/HT										
PROCESS CONNECTION	AJ1	AJ2	AJ4	AA1	AA2	AA4	AD1 to AD4	AJ1	AJ2	AJ4	AA1	AA2	AA4	AD1 AD2	AD3 AD4	AJ1	AJ2	AJ4	AP1 AA1	AP2 AA2	AP4 AA4	AD1 AD2	AD3 AD4
L	75 (2.95)						100 (3.94)						120 (4.72)										
B	37.5 (1.48)						40 (1.57)						50 (1.97)										
C	51.1 (2.01)						71 (2.80)						93.8 (3.69)										
D	92 (3.62)						127 (5.00)						157.2 (6.19)										
H	450.5 (17.74)						485 (19.09)						515 (20.28)										
H1	301 (11.85)						318 (12.52)						333 (13.11)										
E	(Note 1)	45.9 (1.81)	49.8 (1.96)	(Note 1)	48.6 (1.91)	48.6 (1.91)	(Note 1)	57.4 (2.26)	61.2 (2.41)	65.1 (2.56)	(Note 1)	64.4 (2.54)	64.4 (2.54)	61.2 (2.41)	61.2 (2.41)	67 (2.64)	70.8 (2.79)	78.5 (3.09)	72.9 (2.87)	76.6 (3.02)	82.6 (3.25)	68.9 (2.71)	72.7 (2.86)
F	(Note 1)	55.4 (2.18)	60.1 (2.37)	(Note 1)	58.7 (2.31)	58.7 (2.31)	(Note 1)	69.3 (2.73)	73.9 (2.91)	78.5 (3.09)	(Note 1)	77.7 (3.06)	77.7 (3.06)	73.9 (2.91)	73.9 (2.91)	80.8 (3.18)	85.5 (3.37)	94.7 (3.73)	88 (3.46)	92.5 (3.64)	99.7 (3.93)	83.1 (3.27)	87.8 (3.46)
G	(Note 1)	17 (0.67)	17 (0.67)	(Note 1)	17 (0.67)	17 (0.67)	(Note 1)	17 (0.67)	21 (0.83)	21 (0.83)	(Note 1)	20 (0.79)	20 (0.79)	17 (0.67)	17 (0.67)	17 (0.67)	21 (0.83)	23 (0.91)	17 (0.67)	20 (0.79)	23 (0.91)	17 (0.67)	21 (0.83)
WEIGHT kg (lb)	6.4 (14.11)						9.8 (21.61)						13.2 (29.11)										

(Note 1) The holes are not provided.
(Note 2) The flow direction is opposite (right to left when facing onto indicator) in case of code/CRC.

- High Process Temperature Version (/HT): DY025/HT to DY100/HT
- Cryogenic Version (/LT): DY015/LT to DY100/LT
- Flange type

Unit : mm
(approx. inch)

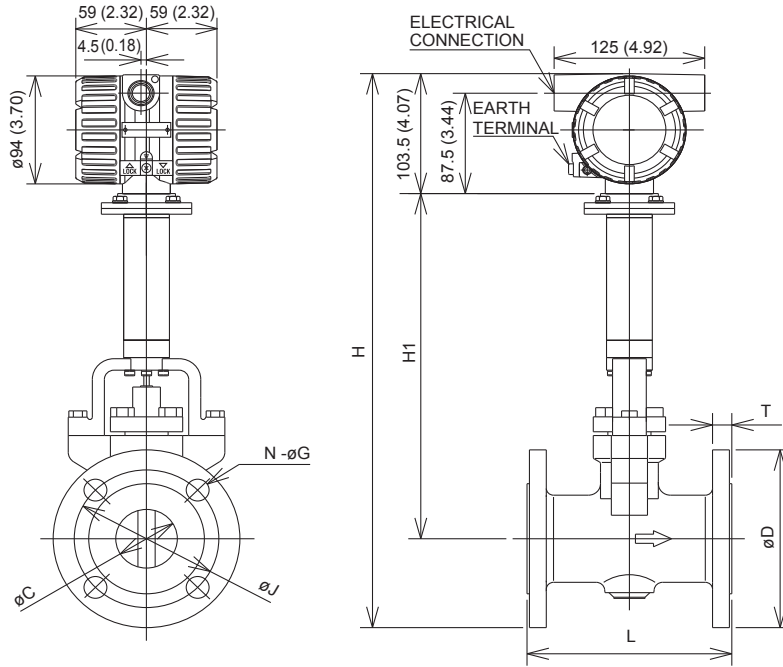

TYPE	REMOTE																			
MODEL CODE	DY015/LT									DY025/LT, DY025/HT										
PROCESS CONNECTION	BJ1	BJ2	BJ4	BA1 BS1	BA2 BS2	BA4 BS4	BA5 BS5	BD1 to BD4	CA4	CA5	BJ1	BJ2	BJ4	BA1 BS1	BA2 BS2	BA4 BS4	BA5 BS5	BD1 to BD4	CA4	CA5
L	130 (5.12)									150 (5.91)										
C	14.6 (0.57)									25.7 (1.01)										
D	95 (3.74)	95 (3.74)	115 (4.53)	88.9 (3.50)	95.3 (3.75)	95.3 (3.75)	120.7 (4.75)	95 (3.74)	95.3 (3.75)	120.7 (4.75)	125 (4.92)	125 (4.92)	130 (5.12)	108 (4.25)	124 (4.88)	124 (4.88)	149.4 (5.88)	115 (4.53)	124 (4.88)	149.4 (5.88)
H	421 (16.57)	421 (16.57)	431 (16.97)	418 (16.46)	421 (16.57)	421 (16.57)	431 (17.09)	421 (16.57)	434 (16.87)	438 (17.09)	421 (16.57)	421 (16.57)	441 (17.24)	430 (16.93)	438 (17.24)	438 (17.24)	450 (17.72)	433 (17.05)	438 (17.24)	450 (17.72)
H1	270 (10.63)									272 (10.71)										
T	12 (0.47)	14 (0.55)	20 (0.79)	11.2 (0.44)	14.2 (0.56)	21 (0.83)	28.8 (1.13)	16 (0.63)	19.9 (0.78)	28.8 (1.13)	14 (0.55)	16 (0.63)	22 (0.87)	14.2 (0.56)	17.5 (0.69)	24 (0.94)	34.9 (1.37)	18 (0.71)	24 (0.94)	34.9 (1.37)
J	70 (2.76)	70 (2.76)	80 (3.15)	80.5 (2.98)	80.5 (2.98)	86.5 (3.38)	82.6 (3.25)	86 (3.38)	86.5 (3.38)	82.6 (3.25)	80 (3.54)	80 (3.54)	85 (3.74)	85 (3.32)	89 (3.50)	89 (3.50)	101.6 (4.00)	85 (3.35)	89 (3.50)	101.6 (4.00)
N	4									4										
G	15 (0.59)	15 (0.59)	19 (0.75)	16.7 (0.66)	17.7 (0.70)	17.7 (0.70)	22.4 (0.88)	14 (0.55)	15.7 (0.62)	22.4 (0.88)	19 (0.75)	19 (0.75)	19 (0.75)	15.7 (0.62)	19 (0.75)	19 (0.75)	25.4 (1.00)	14 (0.55)	19 (0.75)	25.4 (1.00)
WEIGHT kg (lb)	4.6 (10.14)	4.7 (10.36)	6.3 (13.89)	4.5 (9.92)	4.7 (10.36)	4.7 (10.36)	8.2 (18.08)	4.6 (10.14)	4.9 (10.8)	7.2 (15.88)	6.1 (13.66)	6.1 (13.66)	7.5 (16.64)	6.9 (15.44)	7.9 (17.4)	7.9 (17.4)	11.8 (26.26)	6.1 (13.66)	6.9 (15.44)	11.8 (26.26)

TYPE	REMOTE																			
MODEL CODE	DY040/LT, DY040/HT									DY050/LT, DY050/HT										
PROCESS CONNECTION	BJ1	BJ2	BJ4	BA1 BS1	BA2 BS2	BA4 BS4	BA5 BS5	BD1 to BD4	CA4	CA5	BJ1	BJ2	BJ4	BA1 BS1	BA2 BS2	BA4 BS4	BA5 BS5	BD1 to BD4	CA4	CA5
L	150 (5.91)									170 (6.69)										
C	39.7 (1.56)									51.1 (2.01)										
D	140 (5.51)	140 (5.51)	160 (6.30)	127 (5.00)	154.4 (6.12)	155.4 (6.12)	177.8 (7.00)	150 (5.91)	155.4 (6.12)	177.8 (7.00)	155 (6.10)	155 (6.10)	165 (6.50)	152.4 (6.00)	165.1 (6.50)	165.1 (6.50)	215.9 (8.50)	165 (6.50)	165.1 (6.50)	215.9 (8.50)
H	463 (17.83)	463 (17.83)	483 (18.23)	446 (17.56)	460 (18.11)	460 (18.11)	472 (18.58)	460 (18.11)	472 (18.58)	472 (18.58)	463 (18.23)	463 (18.23)	482 (18.98)	461 (18.17)	481 (18.94)	481 (18.94)	513 (20.20)	487 (19.17)	487 (19.17)	513 (20.20)
H1	279 (10.98)									301 (11.85)										
T	16 (0.63)	18 (0.71)	26 (1.02)	17.5 (0.69)	20.6 (0.81)	28.8 (1.13)	38.2 (1.50)	18 (0.71)	28.8 (1.13)	38.2 (1.50)	16 (0.63)	18 (0.71)	26 (1.02)	19.1 (0.75)	22.4 (0.88)	31.8 (1.25)	44.5 (1.75)	20 (0.79)	33.3 (1.31)	46 (1.81)
J	105 (4.13)	105 (4.13)	120 (4.72)	98.6 (3.88)	114.3 (4.50)	114.3 (4.50)	124 (4.88)	110 (4.33)	114.3 (4.50)	124 (4.88)	120 (4.72)	120 (4.72)	130 (5.12)	120.7 (4.75)	127 (5.00)	127 (5.00)	165.1 (6.50)	125 (4.92)	127 (5.00)	165.1 (6.50)
N	4									4										
G	19 (0.75)	19 (0.75)	23 (0.91)	16.7 (0.66)	22.4 (0.88)	22.4 (0.88)	28.4 (1.12)	18 (0.71)	22.4 (0.88)	28.4 (1.12)	19 (0.75)	19 (0.75)	19 (0.75)	15.7 (0.62)	19 (0.75)	19 (0.75)	25.4 (1.00)	18 (0.71)	19 (0.75)	25.4 (1.00)
WEIGHT kg (lb)	8.6 (18.96)	8.8 (19.4)	12.3 (27.12)	8.5 (18.74)	9.5 (21.39)	9.7 (21.52)	16.6 (36.6)	8.2 (18.1)	9.2 (20.29)	16.7 (36.82)	11.5 (25.36)	11.5 (25.36)	14.7 (32.42)	12 (26.68)	12.1 (26.99)	13.6 (29.99)	19.3 (42.76)	11.5 (25.36)	12.1 (26.99)	19.3 (42.76)

TYPE	REMOTE																					
MODEL CODE	DY080/LT, DY080/HT									DY100/LT, DY100/HT												
PROCESS CONNECTION	BJ1	BJ2	BJ4	BA1 BS1	BA2 BS2	BA4 BS4	BA5 BS5	BD1 to BD2	BD3 to BD4	CA4	CA5	BJ1	BJ2	BJ4	BA1 BS1	BA2 BS2	BA4 BS4	BA5 BS5	BD1 to BD2	BD3 to BD4	CA4	CA5
L	200 (7.87)									245 (9.65)		200 (7.87)	235 (9.25)		220 (8.66)							
C	71 (2.80)									318 (12.52)		318 (12.52)		93.6 (3.69)								
D	185 (7.28)	200 (7.87)	210 (8.27)	190.5 (7.50)	209.6 (8.25)	209.6 (8.25)	241.3 (9.50)	200 (7.87)	209.6 (8.25)	241.3 (9.50)	210 (8.27)	225 (8.86)	250 (9.84)	228.6 (9.00)	254 (10.00)	273 (10.75)	292.1 (11.50)	220 (8.66)	235 (9.25)	273 (10.75)	292.1 (11.50)	
H	514 (20.24)	522 (20.55)	527 (20.75)	517 (20.35)	527 (20.75)	527 (20.75)	542 (21.34)	522 (20.55)	542 (20.55)	542 (20.75)	514 (20.24)	542 (21.34)	549 (21.61)	562 (22.13)	562 (21.73)	564 (22.20)	573 (22.56)	547 (21.54)	554 (21.81)	573 (22.56)	583 (22.95)	
H1	318 (12.52)									333 (13.11)		333 (13.11)		333 (13.11)								
T	18 (0.71)	23 (0.87)	32 (1.26)	23.9 (0.94)	28.4 (1.12)	38.2 (1.50)	44.5 (1.75)	20 (0.79)	38.2 (1.50)	44.5 (1.75)	18 (0.71)	24 (0.94)	36 (1.42)	23.9 (0.94)	31.8 (1.25)	44.5 (1.75)	50.9 (2.00)	20 (0.79)	24 (0.94)	31.8 (1.25)	46 (1.81)	
J	150 (5.91)	160 (6.30)	170 (6.69)	152.4 (6.00)	168 (6.61)	168 (6.61)	190.5 (7.50)	160 (6.30)	168 (6.30)	190.5 (7.50)	150 (5.91)	170 (6.69)	185 (7.28)	165 (6.50)	185 (6.50)	190.5 (7.50)	200.2 (7.88)	185 (6.50)	190 (7.48)	216 (8.50)	235 (9.25)	
N	8									8		8		8								
G	19 (0.75)	23 (0.91)	23 (0.91)	16.7 (0.66)	22.4 (0.88)	22.4 (0.88)	28.4 (1.12)	18 (0.71)	22.4 (0.88)	28.4 (1.12)	19 (0.75)	19 (0.75)	19 (0.75)	15.7 (0.62)	19 (0.75)	19 (0.75)	25.4 (1.00)	18 (0.71)	19 (0.75)	25.4 (1.00)	25.4 (1.00)	
WEIGHT kg (lb)	17.8 (39.25)	20.4 (44.98)	25.8 (56.89)	20.4 (44.98)	24.2 (53.36)	25.8 (56.89)	36.1 (79.6)	19.8 (43.66)	20.4 (44.98)	36.1 (79.6)	27.2 (60.04)	27.2 (60.04)	36.1 (79.6)	23.2 (51.16)	23.2 (51.16)	27.7 (61.3)	36.3 (80.04)	25.4 (56.2)	27.8 (61.3)	31.8 (70.4)	31.8 (70.4)	

(Note 1) The flow direction is opposite (right to left when facing out indicator) in case of code/CRC.

■ High Process Temperature Version (/HT): DY150/HT to DY300/HT
 ■ Flange type

Unit : mm
 (approx. inch)

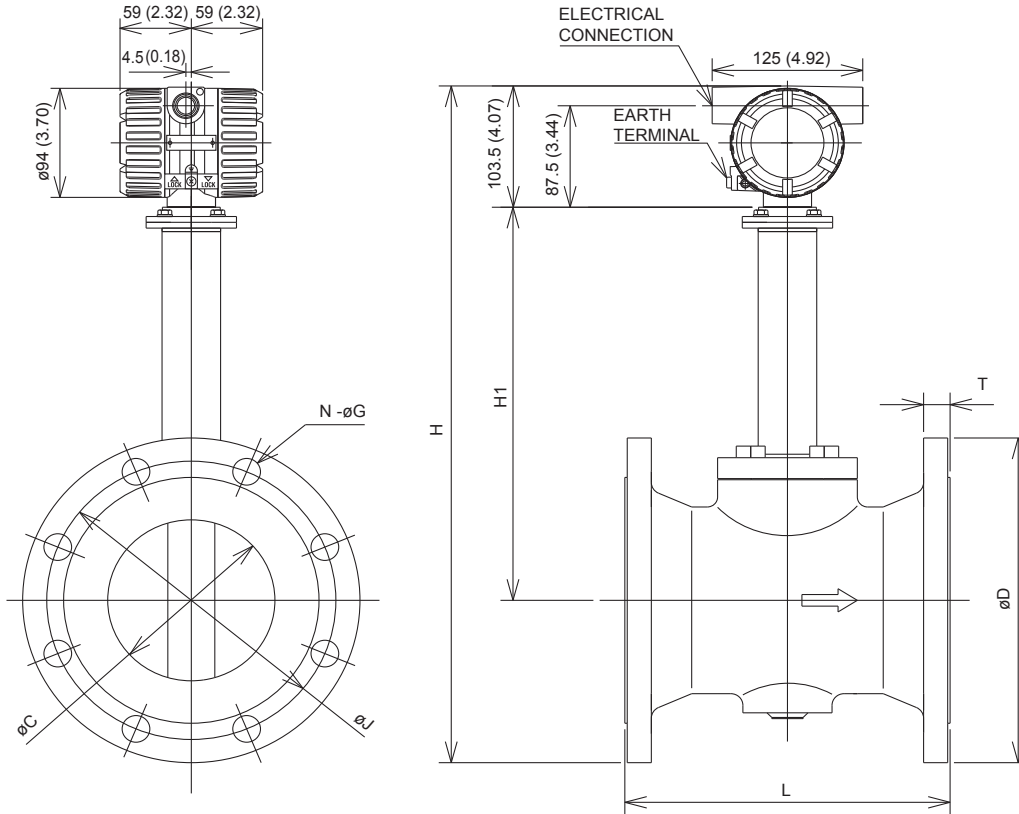

TYPE	REMOTE																							
MODEL CODE	DY150/HT										DY200/HT													
PROCESS CONNECTION	BJ1	BJ2	BJ4	BA1 BS1	BA2 BS2	BA4 BS4	BA5 BS5	BD1 BD2	BD3 BD4	CA4	CA5	BJ1	BJ2	BA1 BS1	BA2 BS2	BA4 BS4	BA5 BS5	BD1	BD2	BD3	BD4	CA4	CA5	
L	270 (10.63)										310 (12.20)													
C	138.8 (5.46)										185.6 (7.31)													
D	280 (11.02)	305 (12.01)	355 (13.98)	279.4 (11.00)	317.5 (12.50)	356 (14.02)	381 (15.00)	285 (11.22)	300 (11.81)	356 (14.02)	381 (15.00)	330 (12.99)	350 (13.78)	342.9 (13.50)	381 (15.00)	419.1 (16.50)	469.9 (18.50)	340 (13.39)	340 (13.39)	360 (14.17)	375 (14.76)	419.1 (16.50)	469.9 (18.50)	
H	Shedder Bar Material: X	583 (22.95)	595 (23.43)	620 (24.41)	582 (22.91)	601 (23.66)	621 (24.45)	633 (24.92)	585 (23.03)	593 (23.35)	621 (24.45)	633 (24.92)	640 (25.20)	650 (25.59)	646 (25.43)	665 (26.16)	684 (26.93)	709 (27.91)	645 (25.39)	645 (25.39)	655 (25.79)	662 (26.06)	684 (26.93)	709 (27.91)
	Shedder Bar Material: B	590 (23.23)	602 (23.70)	627 (24.69)	589 (23.19)	608 (23.94)	628 (24.72)	640 (25.20)	592 (23.31)	600 (23.62)	628 (24.72)	640 (25.20)	647 (25.47)	657 (25.87)	653 (25.71)	672 (26.46)	691 (27.20)	716 (28.19)	652 (25.67)	652 (25.67)	662 (26.06)	669 (26.34)	681 (27.20)	716 (28.19)
H1	339 (13.35)										371 (14.61)													
T	348 (13.62)										378 (14.88)													
	22 (0.87)	28 (1.10)	44 (1.73)	25.4 (1.00)	36.6 (1.44)	54.4 (2.14)	62 (2.44)	22 (0.87)	28 (1.10)	55.7 (2.19)	63.6 (2.50)	22 (0.87)	30 (1.18)	28.4 (1.12)	41.1 (1.62)	62 (2.44)	69.9 (2.75)	24 (0.95)	24 (0.95)	30 (1.18)	34 (1.34)	63.6 (2.50)	71.4 (2.81)	
J	240 (9.45)	260 (10.24)	295 (11.61)	241.3 (9.50)	269.7 (10.62)	292 (11.50)	317.5 (12.50)	240 (9.45)	250 (9.84)	292 (11.50)	317.5 (12.50)	290 (11.42)	305 (12.01)	298.5 (11.75)	330.2 (13.00)	349.3 (13.75)	393.7 (15.50)	295 (11.61)	295 (11.61)	310 (12.20)	320 (12.60)	349.3 (13.75)	393.7 (15.50)	
N	8	12	12	8	12	12	12	8	8	12	12	12	12	8	12	12	12	8	12	12	12	12	12	
G	23 (0.91)	25 (0.98)	33 (1.30)	22.4 (0.88)	22.4 (0.88)	28.4 (1.12)	31.8 (1.25)	22 (0.87)	26 (1.02)	28.4 (1.12)	31.8 (1.25)	23 (0.91)	25 (0.98)	22.4 (0.88)	25.4 (1.00)	31.8 (1.25)	38.1 (1.50)	22 (0.87)	22 (0.87)	26 (1.02)	30 (1.18)	31.8 (1.25)	38.1 (1.50)	
WEIGHT kg (lb)	33.4 (73.65)	43.4 (95.7)	76.4 (168.46)	36.4 (80.26)	54.4 (119.95)	84.4 (186.1)	106 (233.7)	33.4 (73.65)	42.9 (94.59)	90 (198.45)	107 (235.94)	45.4 (100.11)	52.4 (115.54)	55.4 (122.16)	80.4 (177.28)	136 (299.88)	182 (401.31)	46.3 (102.09)	46.3 (102.09)	53.6 (118.19)	55.9 (123.26)	139 (306.5)	183 (403.52)	

TYPE	REMOTE											
MODEL CODE	DY250/HT				DY300/HT				DY400/HT			
PROCESS CONNECTION	BJ1	BJ2	BA1 BS1	BA2 BS2	BJ1	BJ2	BA1 BS1	BA2 BS2	BJ1	BJ2	BA1 BS1	BA2 BS2
L	370 (14.57)				400 (15.75)				520 (20.47)			
C	230.8 (9.09)				276.2 (10.87)				354.2 (13.94)			
D	400 (15.75)	430 (16.93)	406.4 (16.00)	444.5 (17.50)	445 (17.52)	480 (18.90)	482.6 (19.00)	520.7 (20.50)	560 (22.05)	605 (23.82)	596.9 (23.5)	647.7 (25.5)
H	720 (28.35)	735 (28.94)	723 (28.46)	742 (29.21)	772 (30.39)	790 (31.10)	791 (31.14)	810 (31.89)	887.5 (34.94)	910 (35.83)	906 (35.67)	931.4 (36.67)
H1	416 (16.38)				446 (17.56)				504 (19.84)			
T	24 (0.94)	34 (1.34)	30.2 (1.19)	47.8 (1.88)	24 (0.94)	36 (1.42)	31.8 (1.25)	50.8 (2.00)	28 (1.10)	46 (1.81)	36.6 (1.44)	57.2 (2.25)
J	355 (13.98)	380 (14.96)	362 (14.25)	387.4 (15.25)	400 (15.75)	430 (16.93)	431.8 (17.00)	450.9 (17.75)	510 (20.08)	540 (21.26)	539.8 (21.25)	571.5 (22.5)
N	12	12	12	16	16	16	12	16	16	16	16	20
G	25 (0.98)	27 (1.06)	25.4 (1.00)	28.5 (1.12)	25 (0.98)	27 (1.06)	25.4 (1.00)	31.8 (1.25)	27 (1.06)	33 (1.30)	28.5 (1.12)	35.1 (1.38)
WEIGHT kg (lb)	78 (171.99)	100 (220.5)	90 (198.45)	125 (275.63)	100 (220.5)	128 (282.24)	140 (308.7)	178 (392.49)	265 (584.2)	308 (679)	300 (661.4)	370 (815.7)

(Note 1) The flow direction is opposite (right to left when facing onto indicator) in case of code/CRC.

■ Reduced Bore Type (/R1): DY025/R1 to DY150/R1
 ■ Flange type

Unit : mm
 (approx. inch)

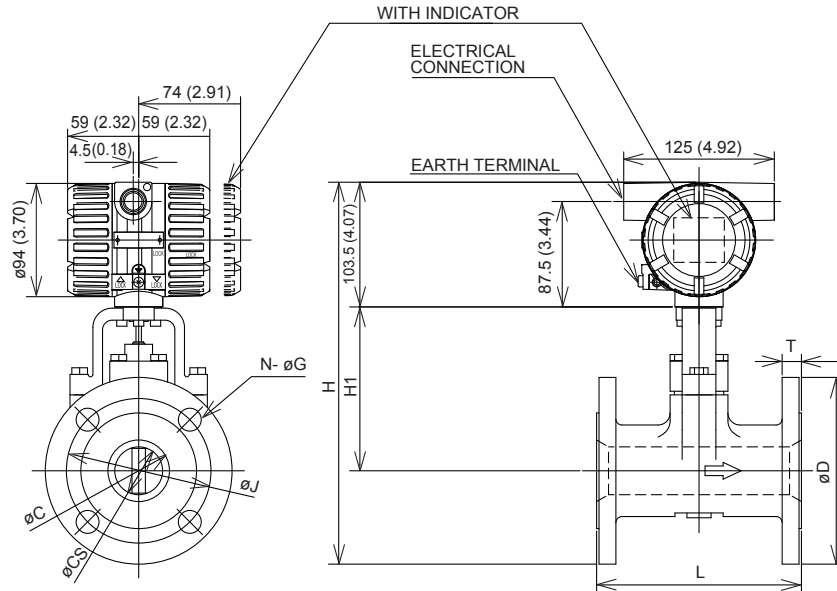

TYPE	INTEGRAL/REMOTE											
MODEL CODE	DY025/R1				DY040/R1				DY050/R1			
PROCESS CONNECTION	BJ1	BJ2	BA1 BS1	BA2 BS2	BJ1	BJ2	BA1 BS1	BA2 BS2	BJ1	BJ2	BA1 BS1	BA2 BS2
L	150 (5.91)				150 (5.90)				170 (6.69)			
C	25.7 (1.01)				39.7 (1.56)				51.1 (2.01)			
CS	14.6 (0.57)				25.7 (1.01)				39.7 (1.56)			
D	125 (4.92)	125 (4.92)	108 (4.25)	124 (4.88)	140 (5.51)	140 (5.51)	127 (5.00)	155.4 (6.12)	155 (6.10)	155 (6.10)	152.4 (6.00)	165.1 (6.50)
H	293 (11.54)	293 (11.54)	284.5 (11.20)	292.5 (11.52)	302.5 (11.91)	302.5 (11.91)	296 (11.65)	310 (12.20)	317 (12.48)	317 (12.48)	315.5 (12.42)	322 (12.68)
H1	127 (5.00)				129 (5.08)				136 (5.35)			
T	14 (0.55)	16 (0.63)	14.2 (0.56)	17.5 (0.69)	16 (0.63)	18 (0.71)	17.5 (0.69)	20.6 (0.81)	16 (0.63)	18 (0.71)	19.1 (0.75)	22.4 (0.88)
J	90 (3.54)	90 (3.54)	79.2 (3.12)	89 (3.50)	105 (4.13)	105 (4.13)	98.6 (3.88)	114.3 (4.5)	120 (4.72)	120 (4.72)	120.7 (4.75)	127 (5.00)
N	4				4				4			
G	19 (0.75)	19 (0.75)	15.7 (0.62)	19 (0.75)	19 (0.75)	19 (0.75)	15.7 (0.62)	22.4 (0.88)	19 (0.75)	19 (0.75)	19 (0.75)	19 (0.75)
WEIGHT kg (lb)	6.1 (13.4)	6.5 (14.3)	5.5 (12.1)	7 (15.4)	9.5 (20.9)	10.1 (22.3)	9.4 (20.7)	12.6 (27.8)	10.5 (23.1)	11.1 (24.5)	11.4 (25.1)	13.6 (30.0)

TYPE	INTEGRAL/REMOTE											
MODEL CODE	DY080/R1				DY100/R1				DY150/R1			
PROCESS CONNECTION	BJ1	BJ2	BA1 BS1	BA2 BS2	BJ1	BJ2	BA1 BS1	BA2 BS2	BJ1	BJ2	BA1 BS1	BA2 BS2
L	200 (7.87)				220 (8.66)				270 (10.63)			
C	71 (2.80)				93.8 (3.69)				138.8 (5.46)			
CS	51.1 (2.01)				71 (2.80)				93.8 (3.69)			
D	185 (7.28)	200 (7.87)	190.5 (7.50)	209.6 (8.25)	210 (8.27)	225 (8.86)	228.6 (9.00)	254 (10.00)	280 (11.02)	305 (12.01)	279.4 (11.00)	317.5 (12.50)
H	354 (13.94)	361.5 (14.23)	357 (14.06)	366.5 (14.43)	383.5 (15.10)	391 (15.39)	393 (15.47)	405.5 (15.97)	433.5 (17.07)	446 (17.56)	433 (17.05)	452 (17.80)
H1	158 (6.22)				175 (6.89)				190 (7.48)			
T	18 (0.71)	22 (0.87)	23.9 (0.94)	28.4 (1.12)	18 (0.71)	24 (0.94)	23.9 (0.94)	31.8 (1.25)	22 (0.87)	28 (1.10)	25.4 (1.00)	36.6 (1.44)
J	150 (5.91)	160 (6.30)	152.4 (6.00)	168.2 (6.62)	175 (6.89)	185 (7.28)	190.5 (7.50)	200.2 (7.88)	240 (9.45)	260 (10.24)	241.3 (9.50)	269.7 (10.62)
N	8	8	4	8	8				8	12	8	12
G	19 (0.75)	23 (0.91)	19 (0.75)	22.4 (0.88)	19 (0.75)	23 (0.91)	19 (0.75)	22.4 (0.88)	23 (0.91)	25 (0.98)	22.4 (0.88)	22.4 (0.88)
WEIGHT kg (lb)	18.6 (41.0)	21.7 (47.8)	21.9 (48.3)	26.9 (59.3)	25 (55.1)	30 (66.1)	30.6 (67.5)	41 (90.4)	45.9 (101.2)	56.3 (124.1)	49.4 (108.9)	71.7 (158.1)

(Note 1) Integral weight is the same as Remote.
 (Note 2) In case of with Indicator, add 0.2kg.
 (Note 3) The flow direction is opposite (right to left when facing onto indicator) in case of code/CRC.

- Reduced Bore Type (/R1): DY200/R1
- Flange type

Unit : mm
(approx. inch)

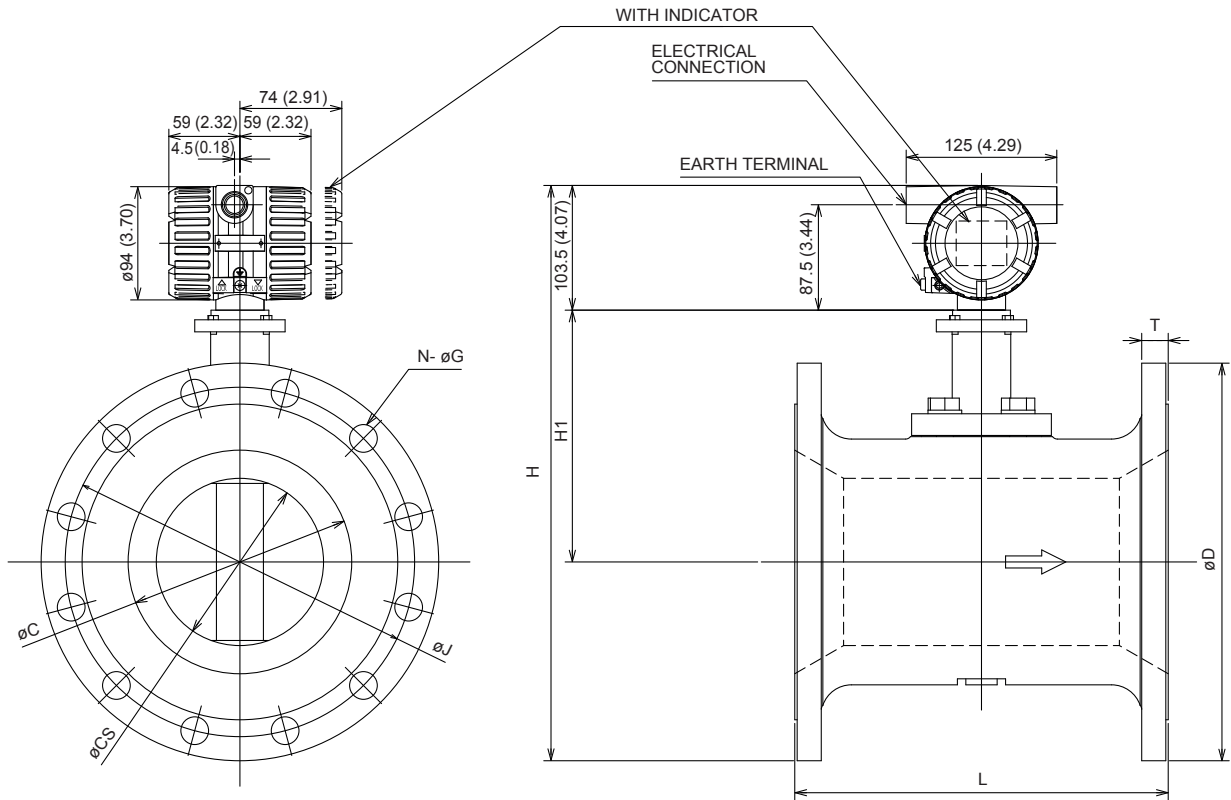

TYPE	INTEGRAL/REMOTE				
MODEL CODE	DY200/R1				
PROCESS CONNECTION	BJ1	BJ2	BA1 BS1	BA2 BS2	
L	310 (12.20)				
C	185.6 (7.31)				
CS	138.8 (5.46)				
D	330 (12.99)	350 (13.78)	342.9 (13.50)	381 (15.00)	
H	Shedder Bar Material: L, E, X	477.5 (18.80)	487.5 (19.19)	484 (19.06)	503 (19.80)
	Shedder Bar Material: B	484.5 (19.07)	494.5 (19.47)	491 (19.33)	510 (20.08)
H1	Shedder Bar Material: L, E, X	209 (8.23)			
	Shedder Bar Material: B	216 (8.50)			
T	22 (0.87)	30 (1.18)	28.4 (1.12)	41.1 (1.62)	
J	290 (11.42)	305 (12.01)	298.5 (11.75)	330.2 (13.00)	
N	12	12	8	12	
G	23 (0.91)	25 (0.98)	22.4 (0.88)	25.4 (1.00)	
WEIGHT kg (lb)	58.7 (129.4)	74.1 (163.4)	70.7 (155.9)	102.9 (226.9)	

(Note 1) Integral weight is the same as Remote.
 (Note 2) In case of with Indicator, add 0.2kg.
 (Note 3) The flow direction is opposite (right to left when facing onto indicator) in case of code/CRC.

■ High Process Temperature Version Reduced Bore Type (/HT/R1): DY040/HT/R1 up to DY150/HT/R1
 ■ Flange type

Unit : mm
 (approx. inch)

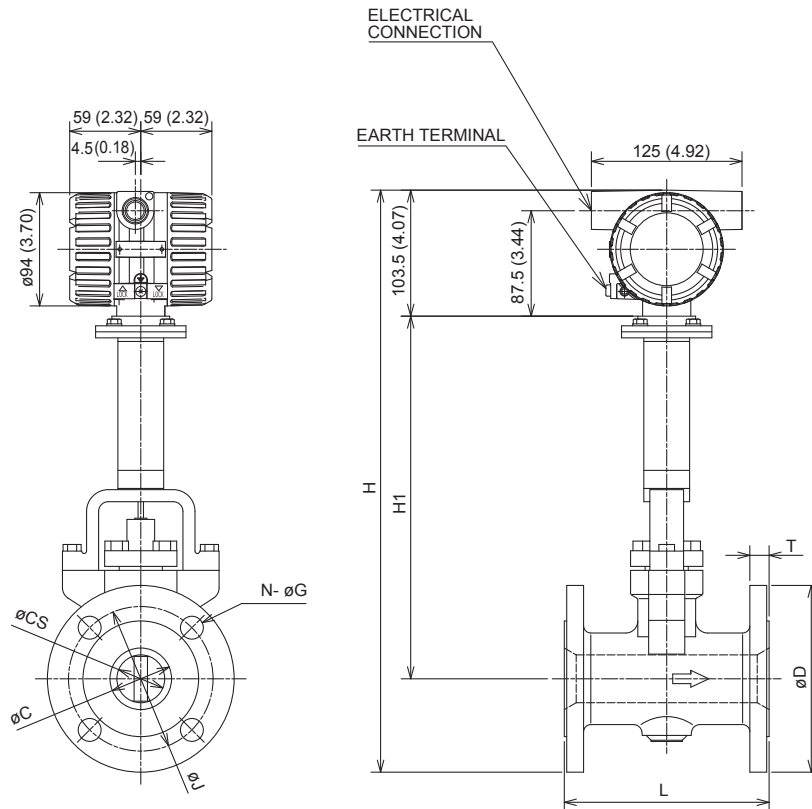

TYPE	REMOTE											
MODEL CODE	DY040/HT/R1				DY050/HT/R1				DY080/HT/R1			
PROCESS CONNECTION	BJ1	BJ2	BA1 BS1	BA2 BS2	BJ1	BJ2	BA1 BS1	BA2 BS2	BJ1	BJ2	BA1 BS1	BA2 BS2
L	150 (5.90)				170 (6.69)				200 (7.87)			
C	39.7 (1.56)				51.1 (2.01)				71 (2.79)			
CS	25.7 (1.01)				39.7 (1.56)				51.1 (2.01)			
D	140 (5.51)	140 (5.51)	127 (5.00)	155.4 (6.12)	155 (6.10)	155 (6.10)	152.4 (6.00)	165.1 (6.50)	185 (7.28)	200 (7.87)	190.5 (7.50)	209.6 (8.25)
H	445.5 (17.54)	445.5 (17.54)	439 (17.28)	453 (17.83)	460 (18.11)	460 (18.11)	458.5 (18.05)	465 (18.30)	497 (19.57)	504.5 (19.86)	500 (19.68)	509.5 (20.05)
H1	272 (10.71)				279 (10.98)				301 (11.85)			
T	16 (0.63)	18 (0.71)	17.5 (0.69)	20.6 (0.81)	16 (0.63)	18 (0.71)	19.1 (0.75)	22.4 (0.88)	18 (0.71)	22 (0.87)	23.9 (0.94)	28.4 (1.11)
J	105 (4.13)	105 (4.13)	98.6 (3.88)	114.3 (4.50)	120 (4.72)	120 (4.72)	120.7 (4.75)	127 (5.00)	150 (5.91)	160 (6.30)	152.4 (6.00)	168.2 (6.62)
N	4				4				4			
G	19 (0.75)	19 (0.75)	15.7 (0.62)	22.4 (0.88)	19 (0.75)	19 (0.75)	19 (0.75)	19 (0.75)	19 (0.75)	23 (0.91)	19 (0.75)	22.4 (0.88)
WEIGHT kg (lb)	10 (22.0)	10.5 (23.1)	9.8 (21.6)	13 (28.7)	10.9 (24.0)	11.5 (25.4)	11.8 (26.0)	14 (30.9)	19 (41.9)	22.1 (48.7)	22.3 (49.2)	27.3 (60.2)

TYPE	REMOTE							
MODEL CODE	DY100/HT/R1				DY150/HT/R1			
PROCESS CONNECTION	BJ1	BJ2	BA1 BS1	BA2 BS2	BJ1	BJ2	BA1 BS1	BA2 BS2
L	220 (8.66)				270 (10.63)			
C	93.8 (3.69)				138.8 (5.46)			
CS	71 (2.79)				93.8 (3.69)			
D	210 (8.27)	225 (8.86)	228.6 (9.00)	254 (10.00)	280 (11.02)	305 (12.01)	279.4 (11.00)	317.5 (12.50)
H	526.5 (20.73)	534 (21.02)	536 (21.10)	548.5 (21.59)	576.5 (22.70)	589 (23.19)	576 (22.68)	595.5 (23.44)
H1	318 (12.52)				333 (13.11)			
T	18 (0.71)	24 (0.94)	23.9 (0.94)	31.8 (1.25)	22 (0.87)	28 (1.10)	25.4 (1.00)	36.6 (1.44)
J	175 (6.89)	185 (7.28)	190.5 (7.50)	200.2 (7.88)	240 (9.45)	260 (10.24)	241.3 (9.50)	269.7 (10.62)
N	8				8			
G	19 (0.75)	23 (0.91)	19 (0.75)	22.4 (0.88)	23 (0.91)	25 (0.98)	22.4 (0.88)	22.4 (0.88)
WEIGHT kg (lb)	25.4 (56.0)	30.4 (67.0)	31 (68.3)	41.4 (91.3)	45.9 (101.2)	56.3 (124.1)	49.4 (108.9)	71.7 (158.1)

(Note 1) The flow direction is opposite (right to left when facing onto indicator) in case of code/CR.C.

- High Process Temperature Version Reduced Bore Type (/HT/R1): DY200/HT/R1
- Flange type

Unit : mm
(approx. inch)

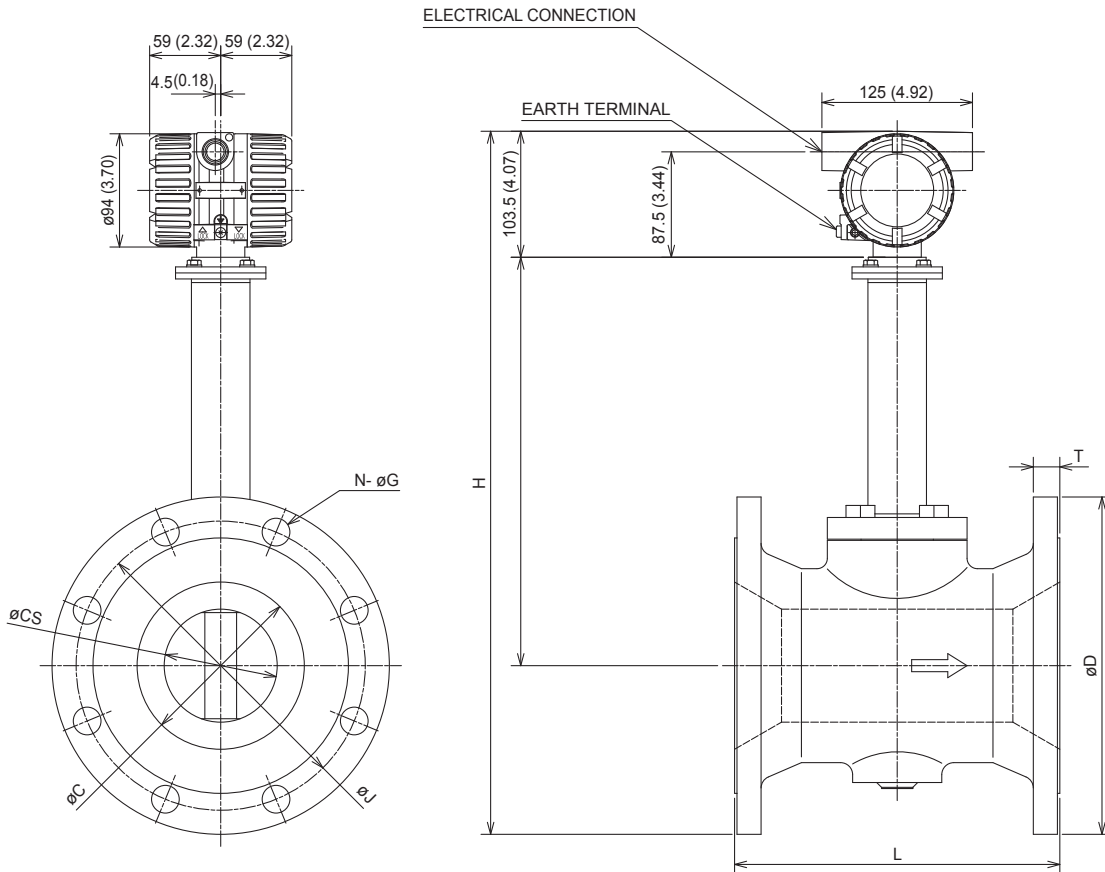

TYPE	REMOTE				
MODEL CODE	DY200/HT/R1				
PROCESS CONNECTION	BJ1	BJ2	BA1 BS1	BA2 BS2	
L	310 (12.20)				
C	185.6 (7.31)				
CS	138.8 (5.46)				
D	330 (12.99)	350 (13.78)	342.9 (13.5)	381 (15.0)	
H	Shedder Bar Material: X	607.5 (23.92)	617.5 (24.31)	614 (24.17)	633 (24.92)
	Shedder Bar Material: B	614.5 (24.19)	624.5 (24.59)	621 (24.45)	640 (25.20)
H1	Shedder Bar Material: X	339 (13.35)			
	Shedder Bar Material: B	346 (13.62)			
T	22 (0.87)	30 (1.18)	28.4 (1.11)	41.1 (1.62)	
J	290 (11.42)	305 (12.01)	298.5 (11.75)	330.2 (13.00)	
N	12	12	8	12	
G	23 (0.91)	25 (0.98)	22.4 (0.88)	25.4 (1.00)	
WEIGHT kg (lb)	58.7 (129.4)	74.1 (163.4)	70.7 (155.9)	102.9 (226.9)	

(Note 1) The flow direction is opposite (right to left when facing onto indicator) in case of code/CRC.

- Reduced Bore Type (/R2): DY040/R2 to DY200/R2
- Flange type

Unit : mm
(approx. inch)

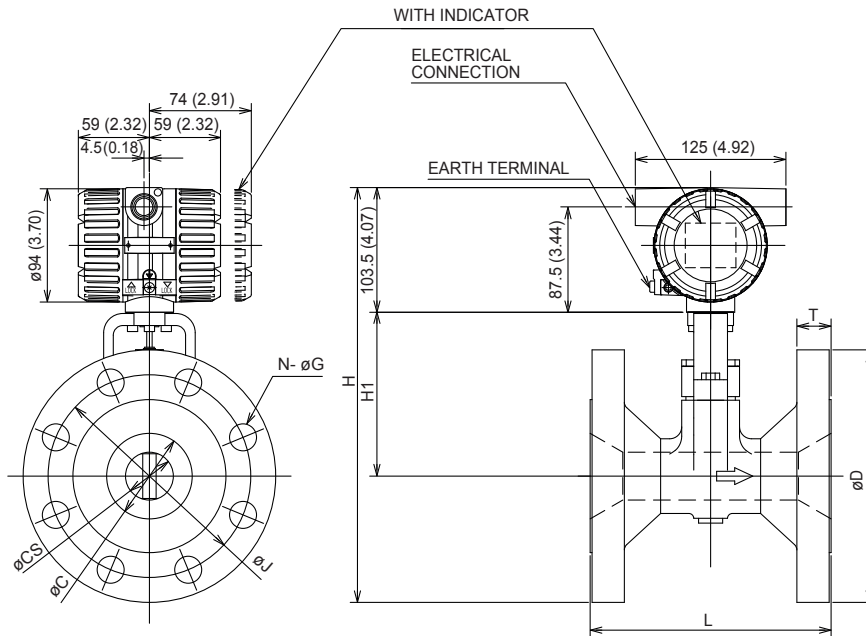

TYPE	INTEGRAL/REMOTE																							
MODEL CODE	DY040/R2				DY050/R2				DY080/R2				DY100/R2				DY150/R2				DY200/R2			
PROCESS CONNECTION	BJ1	BJ2	BA1 BS1	BA2 BS2	BJ1	BJ2	BA1 BS1	BA2 BS2	BJ1	BJ2	BA1 BS1	BA2 BS2	BJ1	BJ2	BA1 BS1	BA2 BS2	BJ1	BJ2	BA1 BS1	BA2 BS2	BJ1	BJ2	BA1 BS1	BA2 BS2
L	150 (5.90)				170 (6.69)				200 (7.87)				220 (8.66)				270 (10.63)				310 (12.20)			
C	39.7 (1.56)				51.1 (2.01)				71 (2.79)				93.8 (3.69)				138.8 (5.46)				185.6 (7.30)			
CS	14.6 (0.57)				25.7 (1.01)				39.7 (1.56)				51.1 (2.01)				71 (2.79)				93.8 (3.69)			
D	140 (5.51)	140 (5.51)	127 (4.94)	155.4 (6.12)	155 (6.10)	155 (6.10)	152.4 (6.00)	165.1 (6.50)	185 (7.28)	200 (7.87)	190.5 (7.50)	209.6 (8.25)	210 (8.27)	225 (8.86)	228.6 (9.00)	254 (10.00)	280 (11.02)	305 (12.01)	279.4 (11.00)	317.5 (12.50)	330 (12.99)	350 (13.78)	342.9 (13.50)	381 (15.00)
H	300.5 (11.83)	300.5 (11.83)	294 (11.57)	308.2 (12.13)	310 (12.20)	310 (12.20)	308.7 (12.15)	315.1 (12.40)	332 (13.07)	339.5 (13.37)	334.8 (13.18)	344.3 (13.55)	366.5 (14.43)	374 (14.72)	375.8 (14.80)	388.5 (15.30)	418.5 (16.48)	431 (16.97)	418.2 (16.46)	437.3 (17.22)	458.5 (18.05)	468.5 (18.44)	465 (18.31)	484 (19.06)
H1	127 (4.94)				129 (5.07)				136 (5.35)				158 (6.22)				175 (6.89)				190 (7.48)			
T	16 (0.63)	18 (0.71)	17.5 (0.69)	20.6 (0.81)	16 (0.63)	18 (0.71)	19.1 (0.75)	22.4 (0.88)	18 (0.71)	22 (0.87)	23.9 (0.94)	28.4 (1.11)	18 (0.71)	24 (0.94)	23.9 (0.94)	31.8 (1.25)	22 (0.87)	28 (1.10)	25.4 (1.00)	36.6 (1.44)	22 (0.87)	30 (1.18)	28.4 (1.11)	41.1 (1.62)
J	105 (4.13)	105 (4.13)	98.6 (3.88)	114.3 (4.50)	120 (4.72)	120 (4.72)	120.7 (4.75)	127 (5.00)	150 (5.91)	160 (6.30)	152.4 (6.00)	168.2 (6.62)	175 (6.89)	185 (7.28)	190.5 (7.50)	200.2 (7.88)	240 (9.45)	260 (10.24)	241.3 (9.50)	269.7 (10.62)	290 (11.42)	305 (11.75)	298.5 (11.75)	330.2 (13.00)
N	4				4	8	4	8	8	8	4	8	8				8	12	8	12	12	12	8	12
G	19 (0.75)	19 (0.75)	15.7 (0.62)	22.4 (0.88)	19 (0.75)				19 (0.75)	23 (0.91)	19 (0.75)	22.4 (0.88)	19 (0.75)	23 (0.91)	19 (0.75)	22.4 (0.88)	23 (0.91)	25 (0.98)	22.4 (0.88)	22.4 (0.88)	23 (0.91)	25 (0.98)	22.4 (0.88)	25.4 (1.00)
WEIGHT kg (lb)	7.7 (17.0)	7.9 (17.4)	7.6 (16.8)	8.8 (19.4)	10 (22.0)	10.5 (23.1)	10.6 (23.4)	12.1 (26.7)	13.6 (30.0)	16.2 (35.7)	16.2 (35.7)	20 (44.1)	20.9 (46.1)	24.9 (54.9)	25.5 (56.2)	34 (75.0)	40.3 (88.8)	50.3 (110.9)	43.3 (95.5)	61.3 (135.1)	61.9 (136.5)	68.9 (151.9)	71.9 (158.5)	96.9 (213.6)

(Note 1) Integral weight is the same as Remote.
 (Note 2) In case of with Indicator, add 0.2kg.
 (Note 3) The flow direction is opposite (right to left when facing onto indicator) in case of code/CRC.

■ High Process Temperature Version Reduced Bore Type (/HT/R2): DY050/HT/R2 to DY200/HT/R2

Unit : mm
(approx. inch)

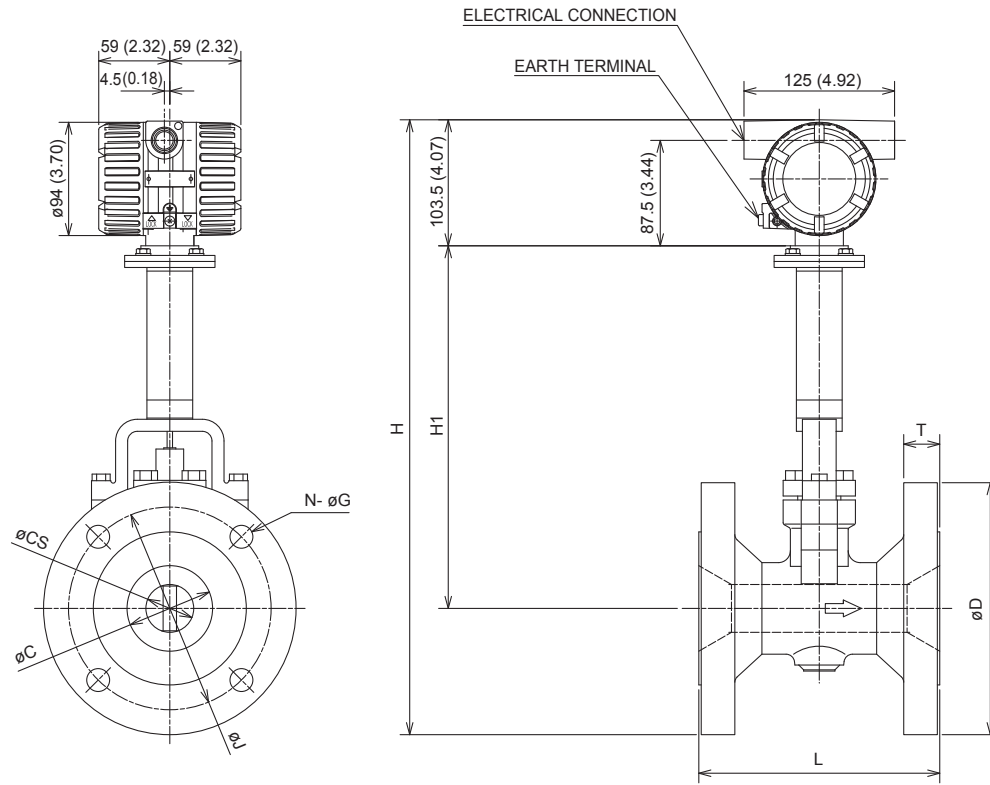

TYPE	REMOTE																			
	DY050/HT/R2				DY080/HT/R2				DY100/HT/R2				DY150/HT/R2				DY200/HT/R2			
MODEL CODE	BJ1	BJ2	BA1 BS1	BA2 BS2	BJ1	BJ2	BA1 BS1	BA2 BS2	BJ1	BJ2	BA1 BS1	BA2 BS2	BJ1	BJ2	BA1 BS1	BA2 BS2	BJ1	BJ2	BA1 BS1	BA2 BS2
L	170 (6.69)				200 (7.87)				220 (8.66)				270 (10.63)				310 (12.20)			
C	51.1 (2.01)				71 (2.79)				93.8 (3.69)				138.8 (5.46)				185.6 (7.30)			
CS	25.7 (1.01)				39.7 (1.56)				51.1 (2.01)				71 (2.79)				93.8 (3.69)			
D	155 (6.10)	155 (6.10)	152.4 (6.00)	165.1 (6.50)	185 (7.28)	200 (7.87)	190.5 (7.50)	209.6 (8.25)	210 (8.27)	225 (8.86)	228.6 (9.00)	254 (10.00)	280 (11.02)	305 (12.01)	279.4 (11.00)	317.5 (12.5)	330 (12.99)	350 (13.78)	342.9 (13.5)	381 (15.00)
H	453 (17.95)	453 (17.95)	451.7 (17.78)	458.1 (18.03)	475 (18.70)	482.5 (19.00)	477.8 (18.81)	487.3 (19.19)	509.5 (20.06)	517 (20.35)	518.8 (20.43)	531.5 (20.93)	561.5 (22.11)	574 (22.60)	561.2 (22.09)	580.3 (22.85)	601.5 (23.68)	611.5 (24.07)	608 (23.94)	627 (24.69)
H1	272 (10.71)				279 (10.98)				301 (11.85)				318 (12.52)				333 (13.11)			
T	16 (0.63)	18 (0.71)	19.1 (0.75)	22.4 (0.88)	18 (0.71)	22 (0.87)	23.9 (0.94)	28.4 (1.11)	18 (0.71)	24 (0.94)	23.9 (0.94)	31.8 (1.25)	22 (0.87)	28 (1.10)	25.4 (1.0)	36.6 (1.44)	22 (0.87)	30 (1.18)	28.4 (1.11)	41.1 (1.62)
J	120 (4.72)	120 (4.72)	120.7 (4.75)	127 (5.00)	150 (5.91)	160 (6.30)	152.4 (6.00)	168.2 (6.62)	175 (6.89)	185 (7.28)	190.5 (7.50)	200.2 (7.88)	240 (9.45)	260 (10.24)	241.3 (9.50)	269.7 (10.62)	290 (11.42)	305 (12.01)	298.5 (11.75)	330.2 (13.00)
N	4	8	4	8	8	8	4	8	8				8	12	8	12	12	12	8	12
G	19 (0.75)				19 (0.75)	23 (0.91)	19 (0.75)	22.4 (0.88)	19 (0.75)	23 (0.91)	19 (0.75)	22.4 (0.88)	23 (0.91)	25 (0.98)	22.4 (0.88)	22.4 (0.88)	23 (0.91)	25 (0.98)	22.4 (0.88)	25.4 (1.00)
WEIGHT kg (lb)	10.4 (23.0)	10.9 (24.0)	11 (24.3)	12.5 (27.6)	14 (30.9)	16.6 (36.6)	16.6 (36.6)	20.4 (45.0)	21.3 (47.0)	25.3 (55.8)	25.9 (57.1)	34.4 (75.8)	40.3 (88.8)	50.3 (110.9)	43.3 (95.5)	61.3 (135.1)	61.9 (136.5)	68.9 (151.9)	71.9 (158.5)	96.9 (213.6)

(Note 1) The flow direction is opposite (right to left when facing onto indicator) in case of code/CRC.

■ Stainless Steel Housing: DY015/E1 to DY100/E1
 ■ Wafer Type

Unit : mm
 (approx. inch)

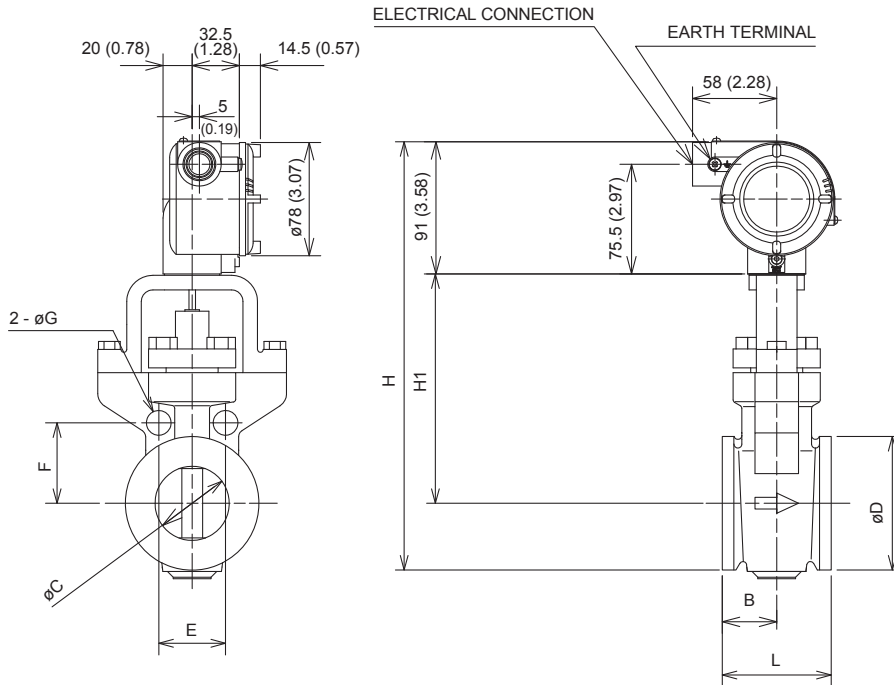

TYPE MODEL CODE	REMOTE																				
	DY015/E1						DY025/E1						DY040/E1								
PROCESS CONNECTION	AJ1	AJ2	AJ4	AA1	AA2	AA4	AD1 to AD4	AJ1	AJ2	AJ4	AA1	AA2	AA4	AD1 to AD4	AJ1	AJ2	AJ4	AA1	AA2	AA4	AD1 to AD4
L	70 (2.76)						70 (2.76)						70 (2.76)								
B	35 (1.38)						35 (1.38)						35 (1.38)								
C	14.6 (0.57)						25.7 (1.01)						39.7 (1.56)								
D	35.1 (1.38)						50.8 (2.00)						73 (2.87)								
H	235.5 (9.27)						245.4 (9.66)						263.5 (10.37)								
H1	127 (5.00)						129 (5.08)						136 (5.35)								
E	49.5 (1.95)	49.5 (1.95)	56.6 (2.23)	42.7 (1.68)	47.1 (1.85)	47.1 (1.85)	46 (1.81)	63.6 (2.50)	63.6 (2.50)	67.2 (2.65)	56 (2.20)	62.9 (2.48)	62.9 (2.48)	60.1 (2.37)	74.2 (2.92)	74.2 (2.92)	84.9 (3.34)	69.7 (2.74)	80.8 (3.18)	80.8 (3.18)	77.8 (3.06)
F	24.7 (0.97)	24.7 (0.97)	28.3 (1.11)	21.4 (0.84)	23.5 (0.93)	23.5 (0.93)	23 (0.91)	31.8 (1.25)	31.8 (1.25)	33.6 (1.32)	28 (1.10)	31.4 (1.24)	31.4 (1.24)	30.1 (1.19)	37.1 (1.46)	37.1 (1.46)	42.4 (1.67)	34.8 (1.37)	40.4 (1.59)	40.4 (1.59)	38.9 (1.53)
G	13 (0.51)	13 (0.51)	17 (0.67)	14 (0.55)	14 (0.55)	14 (0.55)	13 (0.51)	17 (0.67)	17 (0.67)	17 (0.67)	14 (0.55)	17 (0.67)	17 (0.67)	13 (0.51)	17 (0.67)	17 (0.67)	21 (0.83)	14 (0.55)	20 (0.79)	20 (0.79)	17 (0.67)
WEIGHT kg (lb)	2.9 (6.4)						3.8 (8.4)						4.4 (9.7)								

TYPE MODEL CODE	REMOTE																						
	DY050/E1						DY080/E1						DY100/E1										
PROCESS CONNECTION	AJ1	AJ2	AJ4	AA1	AA2	AA4	AD1 to AD4	AJ1	AJ2	AJ4	AA1	AA2	AA4	AD1 AD2	AD3 AD4	AJ1	AJ2	AJ4	AA1	AA2	AA4	AD1 AD2	AD3 AD4
L	75 (2.95)						100 (3.94)						120 (4.72)										
B	37.5 (1.48)						40 (1.57)						50 (1.97)										
C	51.1 (2.01)						71 (2.80)						93.8 (3.69)										
D	92 (3.62)						127 (5.00)						157.2 (6.19)										
H	295 (11.61)						329.5 (12.97)						359.6 (14.16)										
H1	158 (6.22)						175 (6.89)						190 (7.48)										
E	45.9 (1.81)	49.8 (1.96)	48.6 (1.91)	48.6 (1.91)	57.4 (2.26)	61.2 (2.41)	65.1 (2.56)	64.4 (2.54)	64.4 (2.54)	61.2 (2.41)	61.2 (2.41)	67 (2.64)	70.8 (2.79)	78.5 (3.09)	72.9 (2.87)	76.6 (3.02)	82.6 (3.25)	68.9 (2.71)	72.7 (2.86)				
F	55.4 (2.18)	60.1 (2.37)	58.7 (2.31)	58.7 (2.31)	69.3 (2.73)	73.9 (2.91)	78.5 (3.09)	77.7 (3.06)	77.7 (3.06)	73.9 (2.91)	73.9 (2.91)	80.8 (3.18)	85.5 (3.37)	94.7 (3.73)	88 (3.46)	92.5 (3.64)	99.7 (3.93)	83.1 (3.27)	87.8 (3.46)				
G	17 (0.67)	17 (0.67)	17 (0.67)	17 (0.67)	17 (0.67)	21 (0.83)	21 (0.83)	20 (0.79)	20 (0.79)	17 (0.67)	17 (0.67)	17 (0.67)	21 (0.83)	23 (0.91)	17 (0.67)	20 (0.79)	23 (0.91)	17 (0.67)	21 (0.83)				
WEIGHT kg (lb)	6.1 (13.4)						9.5 (20.9)						12.9 (28.4)										

(Note 1) The holes are not provided.
 (Note 2) The flow direction is opposite (right to left when facing onto indicator) in case of code/CRC.

■ **Stainless Steel Housing: DY015/E1 to DY100/E1**
 ■ **Flange type**

Unit : mm
(approx. inch)

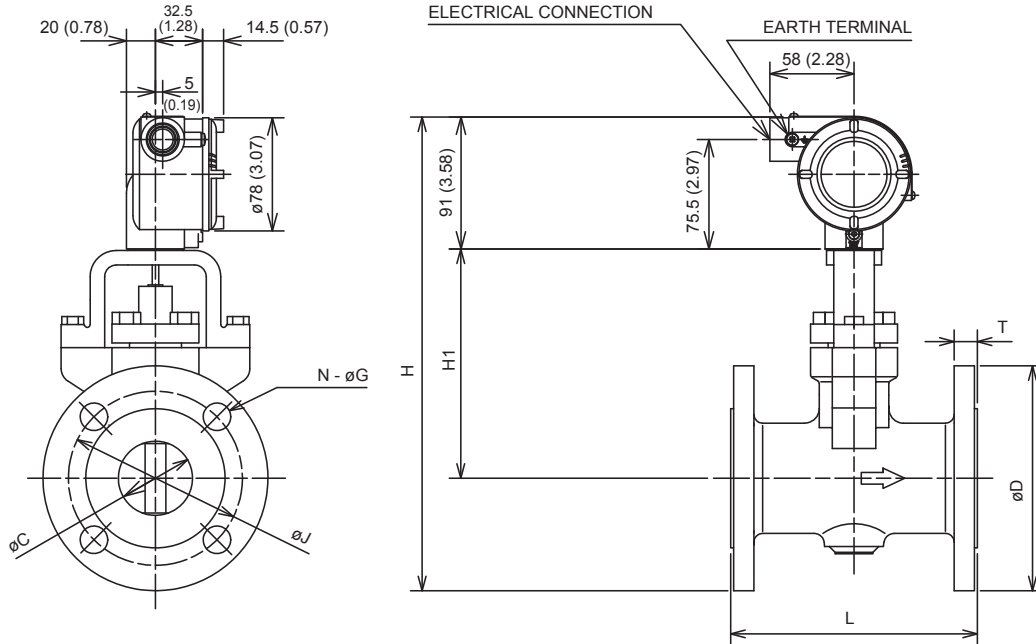

TYPE	REMOTE																			
MODEL CODE	DY015/E1									DY025/E1										
PROCESS CONNECTION	BJ1	BJ2	BJ4	BA1 BS1	BA2 BS2	BA4 BS4	BA5 BS5	BD1 to BD4	CA4	CA5	BJ1	BJ2	BJ4	BA1 BS1	BA2 BS2	BA4 BS4	BA5 BS5	BD1 to BD4	CA4	CA5
L	130 (5.12)									150 (5.91)										
C	14.6 (0.58)									25.7 (1.01)										
D	95 (3.74)	95 (3.74)	115 (4.53)	88.9 (3.5)	95.3 (3.75)	95.3 (3.75)	120.7 (4.75)	95 (3.74)	95.3 (3.75)	120.7 (4.75)	125 (4.92)	125 (4.92)	130 (5.12)	108 (4.25)	124 (4.88)	124 (4.88)	149.4 (5.87)	115 (4.53)	124 (4.88)	149.4 (5.87)
H	265.5 (10.45)	265.5 (10.45)	275.5 (10.85)	262.5 (10.33)	265.5 (10.45)	265.5 (10.45)	278.5 (10.95)	265.5 (10.45)	265.5 (10.45)	278.5 (10.95)	282.5 (11.12)	282.5 (11.12)	285 (11.22)	274 (10.79)	282 (11.10)	282 (11.10)	294.7 (11.60)	277.5 (10.93)	282 (11.10)	294.7 (11.60)
HI	127 (5)									129 (5.08)										
T	12 (0.47)	14 (0.55)	20 (0.79)	11.2 (0.44)	14.2 (0.56)	21 (0.83)	28.8 (1.13)	16 (0.63)	19.9 (0.78)	28.8 (1.13)	14 (0.55)	16 (0.63)	22 (0.87)	14.2 (0.56)	17.5 (0.69)	24 (0.95)	34.9 (1.37)	18 (0.71)	24 (0.95)	34.9 (1.37)
J	70 (2.76)	70 (2.76)	80 (3.15)	60.5 (2.38)	66.5 (2.62)	66.5 (2.62)	82.6 (3.25)	65 (2.56)	66.5 (2.62)	82.6 (3.25)	90 (3.54)	90 (3.54)	95 (3.74)	79.2 (3.12)	89 (3.51)	89 (3.51)	101.6 (4.00)	85 (3.35)	89 (3.51)	101.6 (4.00)
N	4									4										
G	15 (0.59)	15 (0.59)	19 (0.75)	15.7 (0.62)	15.7 (0.62)	15.7 (0.62)	22.4 (0.88)	14 (0.55)	15.7 (0.62)	22.4 (0.88)	19 (0.75)	19 (0.75)	19 (0.75)	15.7 (0.62)	19 (0.75)	19 (0.75)	25.4 (1.00)	14 (0.55)	19 (0.75)	25.4 (1.00)
WEIGHT kg (lb)	4.3 (9.5)	4.4 (9.7)	6 (13.2)	4.2 (9.3)	4.4 (9.7)	4.7 (10.4)	6.8 (15.0)	4.6 (10.1)	6.9 (15.2)	7 (15.4)	7.2 (15.9)	8.7 (19.2)	6.7 (14.8)	7.3 (16.1)	7.3 (16.1)	7.3 (16.1)	11.2 (24.7)	7.4 (16.4)	8 (17.6)	11.5 (25.4)

TYPE	REMOTE																			
MODEL CODE	DY040/E1									DY050/E1										
PROCESS CONNECTION	BJ1	BJ2	BJ4	BA1 BS1	BA2 BS2	BA4 BS4	BA5 BS5	BD1 to BD4	CA4	CA5	BJ1	BJ2	BJ4	BA1 BS1	BA2 BS2	BA4 BS4	BA5 BS5	BD1 to BD4	CA4	CA5
L	150 (5.90)									170 (6.69)										
C	39.7 (1.56)									51.1 (2.01)										
D	140 (5.51)	140 (5.51)	160 (6.30)	127 (5.00)	155.4 (6.12)	155.4 (6.12)	177.8 (7.00)	150 (5.90)	155.4 (6.12)	177.8 (7.00)	155 (6.10)	155 (6.10)	165 (6.50)	152.4 (6.00)	165 (6.50)	165 (6.50)	215.9 (8.50)	165 (6.50)	165 (6.50)	215.9 (8.50)
H	297 (11.69)	297 (11.69)	307 (12.09)	290.5 (11.44)	304.7 (12.00)	304.7 (12.00)	315.9 (12.44)	302 (11.89)	304.7 (12.44)	315.9 (12.44)	326.5 (12.85)	326.5 (12.85)	331.5 (13.05)	325.2 (12.81)	331.5 (13.05)	331.5 (13.05)	357 (14.06)	331.5 (13.05)	331.5 (13.05)	357 (14.06)
HI	136 (5.36)									158 (6.22)										
T	18 (0.63)	18 (0.71)	26 (1.02)	17.5 (0.68)	20.8 (0.81)	28.8 (1.13)	38.2 (1.51)	18 (0.71)	26.8 (1.05)	38.2 (1.51)	16 (0.63)	18 (0.71)	26 (1.02)	19.1 (0.75)	22.4 (0.88)	31.8 (1.25)	44.5 (1.75)	20 (0.79)	33.3 (1.31)	46 (1.81)
J	105 (4.13)	105 (4.13)	120 (4.72)	98.6 (3.88)	114.3 (4.50)	114.3 (4.50)	124 (4.88)	110 (4.33)	114.3 (4.50)	124 (4.88)	120 (4.72)	120 (4.72)	130 (5.12)	120.7 (4.75)	127 (5.00)	127 (5.00)	165 (6.50)	125 (4.92)	127 (5.00)	165 (6.50)
N	4									4										
G	19 (0.75)	19 (0.75)	23 (0.91)	15.7 (0.62)	22.4 (0.88)	22.4 (0.88)	28.4 (1.12)	18 (0.71)	22.4 (0.88)	28.4 (1.12)	19 (0.75)	19 (0.75)	19 (0.75)	19 (0.75)	19 (0.75)	19 (0.75)	25.4 (1.00)	18 (0.71)	19 (0.75)	25.4 (1.00)
WEIGHT kg (lb)	8.3 (18.3)	8.5 (18.7)	12 (26.5)	8.2 (18.1)	9.4 (20.7)	11.4 (25.1)	16.3 (36.0)	8.9 (19.6)	11.8 (26.0)	16.4 (36.2)	11.7 (25.8)	14.4 (31.7)	11.8 (26.0)	13.3 (29.3)	14.9 (32.8)	14.9 (32.8)	26.6 (58.6)	11.4 (25.1)	15.9 (35.1)	27 (60.0)

TYPE	REMOTE																					
MODEL CODE	DY080/E1										DY100/E1											
PROCESS CONNECTION	BJ1	BJ2	BJ4	BA1 BS1	BA2 BS2	BA4 BS4	BA5 BS5	BD1 to BD2	BD3 to BD4	CA4	CA5	BJ1	BJ2	BJ4	BA1 BS1	BA2 BS2	BA4 BS4	BA5 BS5	BD1 to BD2	BD3 to BD4	CA4	CA5
L	200 (7.88)										220 (8.66)											
C	71 (2.80)										93.8 (3.69)											
D	185 (7.28)	200 (7.87)	210 (8.27)	190.5 (7.50)	209.6 (8.25)	209.6 (8.25)	241.3 (9.50)	200 (7.87)	209.6 (8.25)	241.3 (9.50)	210 (8.27)	225 (8.86)	250 (9.84)	228.6 (9.00)	254 (10.00)	273 (10.75)	292.1 (11.50)	220 (8.66)	235 (9.25)	273 (10.75)	292.1 (11.50)	
H	358.5 (14.11)	366 (14.41)	371 (14.61)	361.5 (14.23)	370.8 (14.60)	370.8 (14.60)	386.5 (15.22)	366 (14.41)	370.8 (14.60)	386.5 (15.22)	386 (15.20)	393.5 (15.49)	406 (15.98)	393.5 (15.56)	406 (16.00)	417.5 (16.44)	427 (16.81)	391 (15.39)	398.5 (15.69)	417.5 (16.44)	427 (16.81)	
HI	175 (6.89)										190 (7.48)											
T	18 (0.71)	22 (0.87)	32 (1.26)	23.9 (0.94)	28.4 (1.12)	38.2 (1.51)	44.5 (1.75)	20 (0.79)	24 (0.94)	39.7 (1.56)	46 (1.81)	18 (0.71)	24 (0.94)	36 (1.42)	23.9 (0.94)	31.8 (1.25)	44.5 (1.75)	50.9 (2.00)	20 (0.79)	24 (0.94)	46 (1.81)	
J	150 (5.91)	160 (6.30)	170 (6.69)	152.4 (6.00)	168.2 (6.62)	168 (6.61)	190.5 (7.50)	160 (6.30)	160 (6.30)	168 (6.61)	190.5 (7.50)	175 (6.89)	185 (7.28)	205 (8.07)	190.5 (7.50)	200.2 (7.88)	216 (8.50)	235 (9.25)	180 (7.09)	190 (7.48)	216 (8.50)	235 (9.25)
N	8										8											
G	19 (0.75)	23 (0.91)	23 (0.91)	15.7 (0.62)	22.4 (0.88)	22.4 (0.88)	25.4 (1.00)	18 (0.71)	22.4 (0.88)	25.4 (1.00)	19 (0.75)	23 (0.91)	25 (0.98)	19 (0.75)	22.4 (0.88)	25.4 (1.00)	31.8 (1.25)	18 (0.71)	22 (0.87)	25.4 (1.00)	31.8 (1.25)	
WEIGHT kg (lb)	17.5 (38.6)	20.1 (44.3)	25.5 (56.2)	20.1 (44.3)	23.9 (52.7)	25.5 (56.2)	35.8 (78.8)	19.5 (43.0)	20.1 (44.3)	27.2 (60.0)	36.4 (80.2)	22.9 (50.5)	26.9 (59.3)	38.2 (84.2)	27.5 (61.0)	36 (79.4)	50.9 (112.2)	56 (123.4)	23.3 (51.4)	27.5 (61.0)	52.9 (117.0)	56.7 (125.0)

(Note 1) The flow direction is opposite (right to left when facing onto indicator) in case of code/CRC.

- Stainless Steel Housing: DY150/E1 to DY400/E1
- Flange type

Unit : mm
(approx. inch)

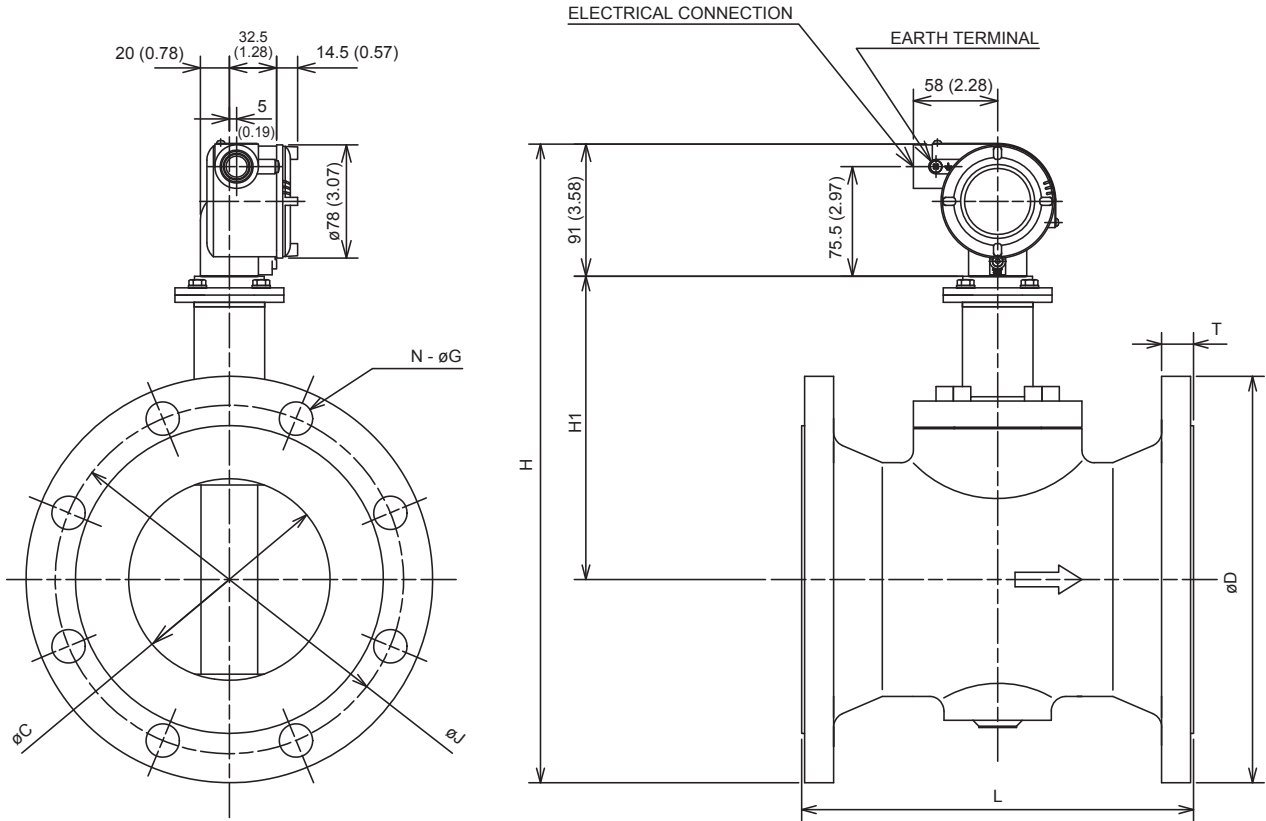

TYPE	DY150/E1										DY200/E1														
	BJ1	BJ2	BJ4	BA1 BS1	BA2 BS2	BA4 BS4	BA5 BS5	BD1 BD2	BD3 BD4	CA4	CA5	BJ1	BJ2	BA1 BS1	BA2 BS2	BA4 BS4	BA5 BS5	BD1	BD2	BD3	BD4	CA4	CA5		
L	270 (10.63)					310 (12.20)					270 (10.63)					325 (12.80)					340 (13.39)				
C	138.8 (5.46)										185.6 (7.31)														
D	280 (11.02)	305 (12.01)	355 (13.98)	279.4 (11.00)	317.5 (12.50)	356 (14.02)	381 (15.00)	285 (11.22)	300 (11.81)	356 (14.02)	381 (15.00)	330 (12.99)	350 (13.78)	342.9 (13.50)	381 (15.00)	419.1 (16.50)	469.9 (18.50)	340 (13.39)	360 (14.17)	375 (14.76)	419.1 (16.50)	469.9 (18.50)			
H	Shedder Bar Material: L, E, X																								
H	Shedder Bar Material: B																								
H1	209 (8.23)										241 (9.49)														
T	216 (8.50)										248 (9.76)														
J	240 (9.45)	280 (11.02)	295 (11.61)	241.3 (9.50)	269.7 (10.62)	292 (11.50)	292 (11.50)	250 (9.84)	250 (9.84)	292 (11.50)	292 (11.50)	290 (11.42)	305 (12.01)	298.5 (11.74)	330.2 (13.00)	349.3 (13.75)	393.7 (15.50)	295 (11.61)	295 (11.61)	310 (12.20)	320 (12.60)	349.3 (13.75)	393.7 (15.50)		
N	8 (0.31)	12 (0.47)	12 (0.47)	8 (0.31)	12 (0.47)	12 (0.47)	8 (0.31)	12 (0.47)	12 (0.47)	8 (0.31)	12 (0.47)	8 (0.31)	12 (0.47)	12 (0.47)	8 (0.31)	12 (0.47)	12 (0.47)	8 (0.31)	12 (0.47)	12 (0.47)	8 (0.31)	12 (0.47)	12 (0.47)		
G	23 (0.91)	25 (0.98)	33 (1.30)	22.4 (0.88)	22.4 (0.88)	28.4 (1.12)	31.8 (1.25)	22 (0.87)	26 (1.02)	28.4 (1.12)	31.8 (1.25)	23 (0.91)	25 (0.98)	22.4 (0.88)	25.4 (1.00)	31.8 (1.25)	38.1 (1.50)	22 (0.87)	22 (0.87)	26 (1.02)	30 (1.18)	31.8 (1.25)	38.1 (1.50)		
WEIGHT kg (lb)	33.5 (73.9)	43.5 (96.0)	76.5 (168.7)	38.5 (85.0)	54.5 (120.2)	84.5 (186.3)	106.1 (234.0)	33.5 (73.9)	43 (94.8)	90.1 (198.7)	107.1 (236.1)	45.5 (100.3)	52.5 (115.7)	55.5 (122.4)	80.5 (177.5)	136.1 (300.0)	182.1 (401.5)	46.4 (102.3)	46.4 (102.3)	53.7 (118.4)	56 (123.5)	139.1 (306.7)	183.1 (403.7)		

TYPE	DY250/E1						DY300/E1						DY400/E1										
	BJ1	BJ2	BA1 BS1	BA2 BS2	BJ1	BJ2	BA1 BS1	BA2 BS2	BJ1	BJ2	BA1 BS1	BA2 BS2	BJ1	BJ2	BA1 BS1	BA2 BS2							
L	370 (14.57)						400 (15.75)						520 (20.47)										
C	230.8 (9.09)						276.2 (10.87)						354.2 (13.94)										
D	400 (15.75)	430 (16.93)	486.4 (19.00)	444.5 (17.50)	445 (17.52)	480 (18.90)	482.6 (19.00)	520.7 (20.50)	560 (22.05)	605 (23.82)	651 (25.62)	697 (27.45)	560 (22.05)	605 (23.82)	651 (25.62)	697 (27.45)							
H	568 (22.36)	583 (23.07)	571.2 (22.49)	590.5 (23.25)	620.5 (24.43)	638 (25.12)	639.3 (25.17)	658.5 (25.93)	745 (29.33)	767.5 (30.22)	763.5 (30.06)	788.5 (31.04)	745 (29.33)	767.5 (30.22)	763.5 (30.06)	788.5 (31.04)							
H1	277 (10.91)						307 (12.09)						374 (14.72)										
T	24 (0.94)	34 (1.34)	30.2 (1.19)	47.8 (1.88)	24 (0.94)	36 (1.42)	31.8 (1.25)	50.8 (2.00)	28 (1.10)	46 (1.81)	36.6 (1.44)	57.2 (2.25)	28 (1.10)	46 (1.81)	36.6 (1.44)	57.2 (2.25)							
J	35 (13.98)	380 (14.96)	362 (14.25)	387.4 (15.25)	400 (15.75)	430 (16.93)	431.8 (17.00)	450.9 (17.75)	510 (20.08)	540 (21.26)	539.8 (21.25)	571.5 (22.50)	510 (20.08)	540 (21.26)	539.8 (21.25)	571.5 (22.50)							
N	12 (0.47)	12 (0.47)	12 (0.47)	16 (0.63)	16 (0.63)	16 (0.63)	12 (0.47)	16 (0.63)	16 (0.63)	16 (0.63)	16 (0.63)	20 (0.79)	12 (0.47)	12 (0.47)	12 (0.47)	16 (0.63)	16 (0.63)	16 (0.63)	16 (0.63)	16 (0.63)	16 (0.63)	20 (0.79)	
G	25 (0.98)	27 (1.06)	25.4 (1.00)	28.5 (1.12)	25 (0.98)	27 (1.06)	25.4 (1.00)	31.8 (1.25)	27 (1.06)	33 (1.30)	28.5 (1.12)	35.1 (1.38)	25 (0.98)	27 (1.06)	25.4 (1.00)	28.5 (1.12)	27 (1.06)	27 (1.06)	28.5 (1.12)	30 (1.18)	30 (1.18)	30 (1.18)	37.1 (16.60)
WEIGHT kg (lb)	78.1 (172.1)	100.1 (220.7)	90.1 (198.7)	125.1 (275.8)	100.1 (220.7)	128.1 (282.4)	140.1 (308.9)	178.1 (392.6)	107.1 (236.1)	140.1 (308.9)	178.1 (392.6)	265.1 (584.4)	107.1 (236.1)	140.1 (308.9)	178.1 (392.6)	265.1 (584.4)	107.1 (236.1)	140.1 (308.9)	178.1 (392.6)	265.1 (584.4)	300.1 (661.6)	370.1 (816.0)	

(Note 1) The flow direction is opposite (right to left when facing onto indicator) in case of code/CRC.

■ Stainless Steel Housing Reduced Bore Type (/R1/E1): DY025/R1/E1 to DY150/R1/E1
 ■ Flange type

Unit : mm
 (approx. inch)

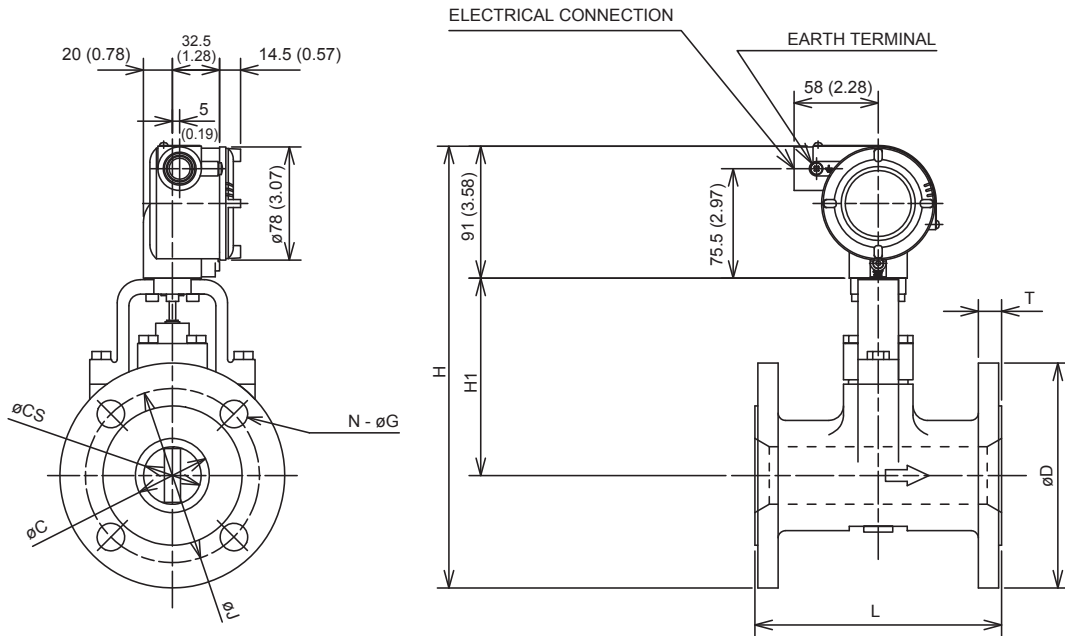

TYPE	REMOTE																							
MODEL CODE	DY025/R1/E1				DY040/R1/E1				DY050/R1/E1				DY080/R1/E1				DY100/R1/E1				DY150/R1/E1			
PROCESS CONNECTION	BJ1	BJ2	BA1 BS1	BA2 BS2	BJ1	BJ2	BA1 BS1	BA2 BS2	BJ1	BJ2	BA1 BS1	BA2 BS2	BJ1	BJ2	BA1 BS1	BA2 BS2	BJ1	BJ2	BA1 BS1	BA2 BS2	BJ1	BJ2	BA1 BS1	BA2 BS2
L	150 (5.91)				150 (5.91)				170 (6.69)				200 (7.87)				220 (8.66)				270 (10.63)			
C	25.7 (1.01)				39.7 (1.56)				51.1 (2.01)				71 (2.79)				93.8 (3.69)				138.8 (5.46)			
CS	14.6 (0.57)				25.7 (1.01)				39.7 (1.56)				51.1 (2.01)				71 (2.79)				93.8 (3.69)			
D	125 (4.92)	125 (4.92)	108 (4.25)	124 (4.88)	140 (5.51)	140 (5.51)	127 (4.94)	155.4 (6.12)	155 (6.10)	155 (6.10)	152.4 (6.00)	165.1 (6.50)	185 (7.28)	200 (7.87)	190.5 (7.50)	209.6 (8.25)	210 (8.27)	225 (8.86)	228.6 (9.00)	254 (10.00)	280 (11.02)	305 (12.01)	279.4 (11.00)	317.5 (12.50)
H	280.5 (11.04)	280.5 (11.04)	272 (10.71)	280 (11.02)	290 (11.42)	290 (11.42)	283.5 (11.16)	297.7 (11.72)	304.5 (11.99)	304.5 (11.99)	303.2 (11.94)	309.5 (12.16)	341.5 (13.44)	349 (13.74)	344.5 (13.57)	353.8 (13.93)	371 (14.61)	378.5 (14.90)	380.3 (14.97)	393 (15.47)	421 (16.57)	433.5 (17.07)	420.7 (16.56)	439.5 (17.31)
H1	127 (5.00)				129 (5.07)				136 (5.35)				158 (6.22)				175 (6.89)				190 (7.48)			
T	14 (0.55)	16 (0.63)	14.2 (0.56)	17.5 (0.69)	16 (0.63)	18 (0.71)	17.5 (0.69)	20.6 (0.81)	16 (0.63)	18 (0.71)	19.1 (0.75)	22.4 (0.88)	18 (0.71)	22 (0.87)	23.9 (0.94)	28.4 (1.11)	18 (0.71)	24 (0.94)	23.9 (0.94)	31.8 (1.25)	22 (0.87)	28 (1.10)	25.4 (1.00)	36.6 (1.44)
J	90 (3.54)	90 (3.54)	79.2 (3.12)	89 (3.50)	105 (4.13)	105 (4.13)	98.6 (3.88)	114.3 (4.50)	120 (4.72)	120 (4.72)	120.7 (4.75)	127 (5.00)	150 (5.91)	160 (6.30)	152.4 (6.00)	168.2 (6.62)	175 (6.89)	185 (7.28)	190.5 (7.50)	200.2 (7.88)	240 (9.45)	260 (10.24)	241.3 (9.50)	269.7 (10.62)
N	4				4				4				8				8				8			
G	19 (0.75)	19 (0.75)	15.7 (0.62)	19 (0.75)	19 (0.75)	19 (0.75)	15.7 (0.62)	22.4 (0.88)	19 (0.75)	19 (0.75)	19 (0.75)	19 (0.75)	19 (0.75)	23 (0.91)	19 (0.75)	22.4 (0.88)	19 (0.75)	23 (0.91)	19 (0.75)	22.4 (0.88)	23 (0.91)	25 (0.98)	22.4 (0.88)	22.4 (0.88)
WEIGHT kg (lb)	6.2 (13.7)	6.6 (14.6)	5.6 (12.3)	7.1 (15.7)	9.7 (21.4)	10.2 (22.5)	9.5 (21.0)	12.7 (30.1)	10.6 (23.4)	11.2 (24.7)	11.5 (25.4)	13.7 (30.2)	18.7 (41.2)	21.8 (48.1)	22 (49.0)	27 (60.0)	25.1 (55.3)	30.1 (66.4)	30.7 (67.7)	41.4 (91.3)	46 (101.4)	56.4 (124.3)	49.5 (109.1)	71.8 (158.3)

(Note 1) The flow direction is opposite (right to left when facing onto indicator) in case of code/CRC.

- Stainless Steel Housing Reduced Bore Type (/R1/E1): DY200/R1/E1
- Flange type

Unit : mm
(approx. inch)

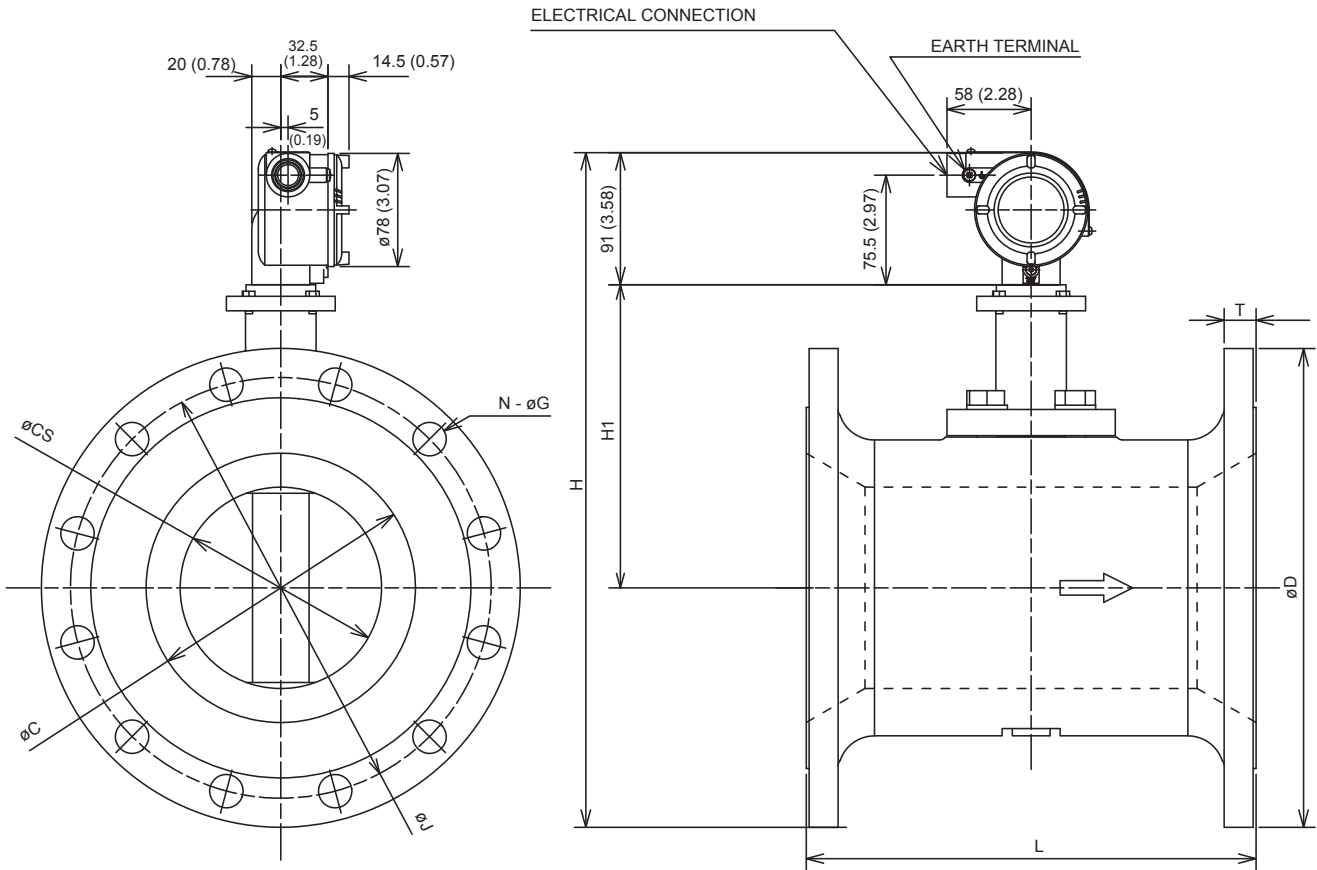

TYPE	REMOTE				
MODEL CODE	DY200/R1/E1				
PROCESS CONNECTION	BJ1	BJ2	BA1 BS1	BA2 BS2	
L	310 (12.20)				
C	185.6 (7.31)				
CS	138.8 (5.46)				
D	330 (12.99)	350 (13.78)	342.9 (13.50)	381 (15.00)	
H	Shedder Bar Material: L, E, X	465 (18.31)	475 (18.70)	471.5 (18.56)	490.5 (19.31)
	Shedder Bar Material: B	472 (18.58)	482 (18.98)	478.5 (18.84)	497.5 (19.59)
H1	Shedder Bar Material: L, E, X	209 (8.23)			
	Shedder Bar Material: B	216 (8.50)			
T	22 (0.87)	30 (1.18)	28.4 (1.12)	41.1 (1.62)	
J	290 (11.42)	305 (12.01)	298.5 (11.75)	330.2 (13.00)	
N	12	12	8	12	
G	23 (0.91)	25 (0.98)	22.4 (0.88)	25.4 (1.00)	
WEIGHT kg (lb)	58.8 (129.6)	74.2 (163.6)	70.8 (156.1)	103 (227.1)	

(Note 1) The flow direction is opposite (right to left when facing onto indicator) in case of code/CRC.

■ Stainless Steel Housing Reduced Bore Type (/R2/E1): DY040/R1/E1 to DY200/R2/E1
 ■ Flange type

Unit : mm
 (approx. inch)

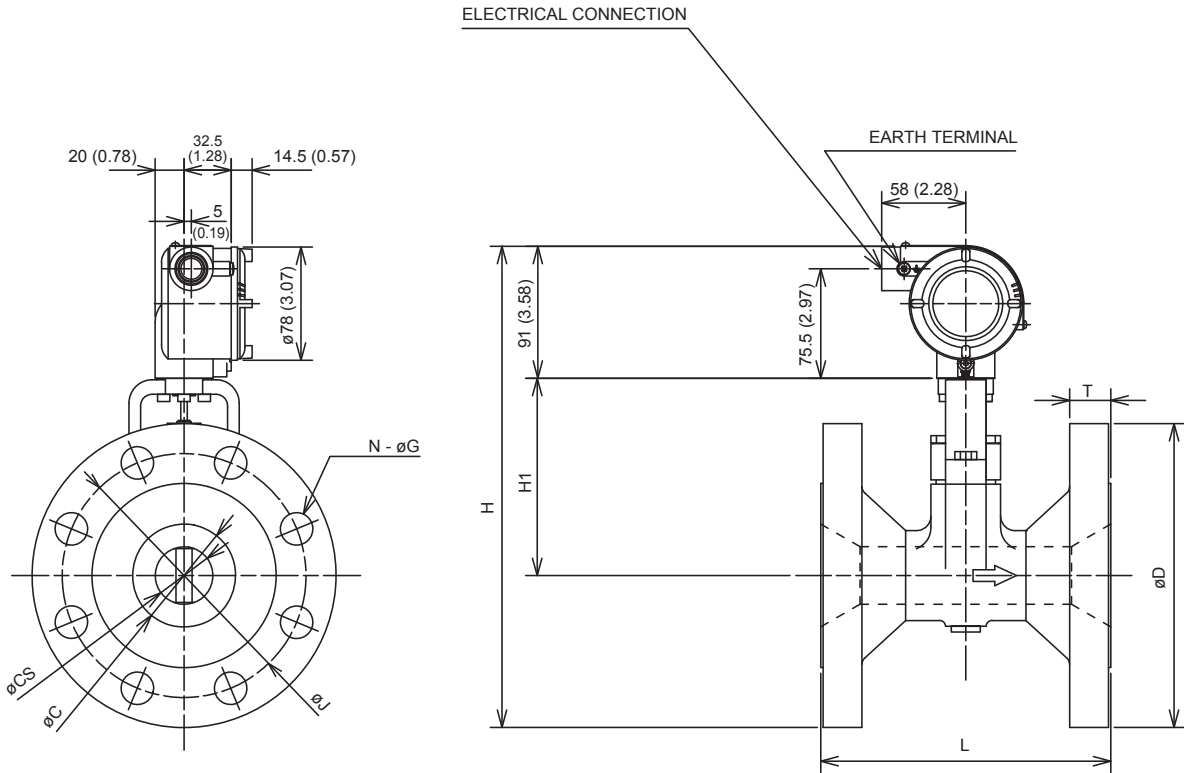

TYPE	REMOTE																							
	DY040/R2/E1				DY050/R2/E1				DY080/R2/E1				DY100/R2/E1				DY150/R2/E1				DY200/R2/E1			
MODEL CODE	BJ1	BJ2	BA1 BS1	BA2 BS2	BJ1	BJ2	BA1 BS1	BA2 BS2	BJ1	BJ2	BA1 BS1	BA2 BS2	BJ1	BJ2	BA1 BS1	BA2 BS2	BJ1	BJ2	BA1 BS1	BA2 BS2	BJ1	BJ2	BA1 BS1	BA2 BS2
L	150 (5.91)				170 (6.69)				200 (7.87)				220 (8.66)				270 (10.63)				310 (12.20)			
C	39.7 (1.56)				51.1 (2.01)				71 (2.79)				93.8 (3.69)				138.8 (5.46)				185.6 (7.30)			
CS	14.6 (0.57)				25.7 (1.01)				39.7 (1.56)				51.1 (2.01)				71 (2.79)				93.8 (3.69)			
D	140 (5.51)	140 (5.51)	127 (4.94)	155.4 (6.12)	155 (6.10)	155 (6.10)	152.4 (6.00)	165.1 (6.50)	185 (7.28)	200 (7.87)	190.5 (7.50)	209.6 (8.25)	210 (8.27)	225 (8.86)	228.6 (9.00)	254 (10.00)	280 (11.02)	305 (12.01)	279.4 (11.00)	317.5 (12.50)	330 (12.99)	350 (13.78)	342.9 (13.50)	381 (15.00)
H	288 (11.34)	288 (11.34)	281.5 (11.08)	295.7 (11.64)	297.5 (11.71)	297.5 (11.71)	296.2 (11.66)	302.5 (11.91)	319.5 (12.58)	327 (12.87)	322.5 (12.70)	331.8 (13.06)	354 (13.94)	361.5 (14.23)	363.3 (14.30)	376 (14.80)	406 (15.98)	418.5 (16.48)	405.7 (15.97)	424.5 (16.71)	446 (17.56)	456 (17.95)	452.5 (17.82)	471.5 (18.56)
H1	127 (5.00)				129 (5.07)				136 (5.35)				158 (6.22)				175 (6.89)				190 (7.48)			
T	16 (0.63)	18 (0.71)	17.5 (0.69)	20.6 (0.81)	16 (0.63)	18 (0.71)	19.1 (0.75)	22.4 (0.88)	18 (0.71)	22 (0.87)	23.9 (0.94)	28.4 (1.11)	18 (0.71)	24 (0.94)	23.9 (0.94)	31.8 (1.25)	22 (0.87)	28 (1.10)	25.4 (1.00)	36.6 (1.44)	22 (0.87)	30 (1.18)	28.4 (1.11)	41.1 (1.62)
J	105 (4.13)	105 (4.13)	98.6 (3.88)	114.3 (4.50)	120 (4.72)	120 (4.72)	120.7 (4.75)	127 (5.00)	150 (5.91)	160 (6.30)	152.4 (6.00)	168.2 (6.62)	175 (6.89)	185 (7.28)	190.5 (7.50)	200.2 (7.88)	240 (9.45)	260 (10.24)	241.3 (9.50)	269.7 (10.62)	290 (11.42)	305 (12.01)	298.5 (11.75)	330.2 (13.00)
N	4				4	8	4	8	8	8	4	8	8				8	12	8	12	12	12	8	12
G	19 (0.75)	19 (0.75)	15.7 (0.62)	22.4 (0.88)	19 (0.75)				19 (0.75)	23 (0.91)	19 (0.75)	22.4 (0.88)	19 (0.75)	23 (0.91)	19 (0.75)	22.4 (0.88)	23 (0.91)	25 (0.98)	22.4 (0.88)	22.4 (0.88)	23 (0.91)	25 (0.98)	22.4 (0.88)	25.4 (1.00)
WEIGHT kg (lb)	7.8 (17.2)	8 (17.6)	7.7 (17.1)	8.9 (20.0)	10.1 (22.3)	10.6 (23.4)	10.7 (23.6)	12.2 (26.9)	13.7 (30.2)	16.3 (36.0)	16.3 (36.0)	20.1 (44.3)	21 (46.3)	25 (55.1)	25.6 (56.4)	34.1 (75.2)	40.4 (89.1)	50.4 (111.1)	43.4 (95.7)	61.4 (135.4)	62 (136.7)	69 (152.1)	72 (158.7)	97 (213.8)

(Note 1) The flow direction is opposite (right to left when facing onto indicator) in case of code/CRC.

■ Remote Type Converter (DYA)

Unit : mm
(approx. inch)

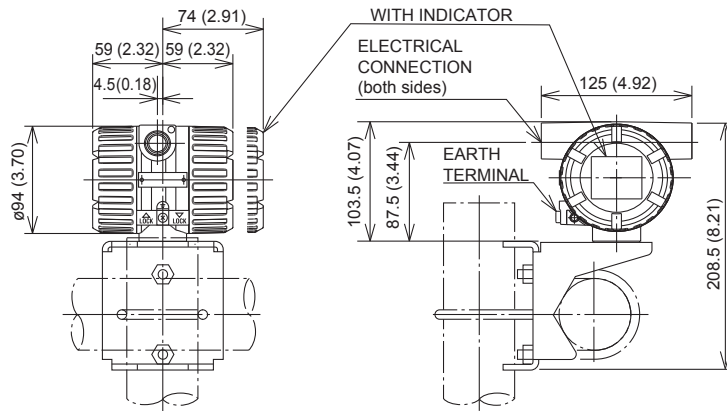

Weight: 1.9 kg (4.19lb), 4.1 kg (9.04lb) for /E1.
Note: For flowmeters with indicator, add 0.2 kg (0.44lb), 0.3 kg (0.66lb) for /E1.

■ Signal Cable for Remote Type (DYC)

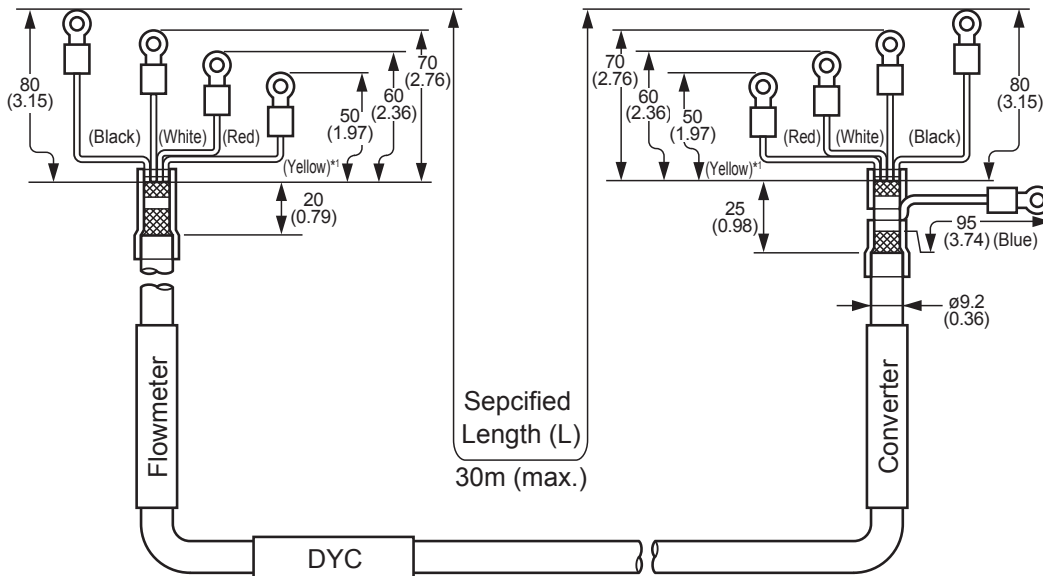

Cable Color and Terminal

Color	Terminal	
	Flow meter	Converter
Yellow ^(*)	T	T
Red	A	A
White	B	B
Black	⊕	C
Blue		⊕

(*) Only for /MV

■ Flameproof Packing Adapter (/G11, /G12)

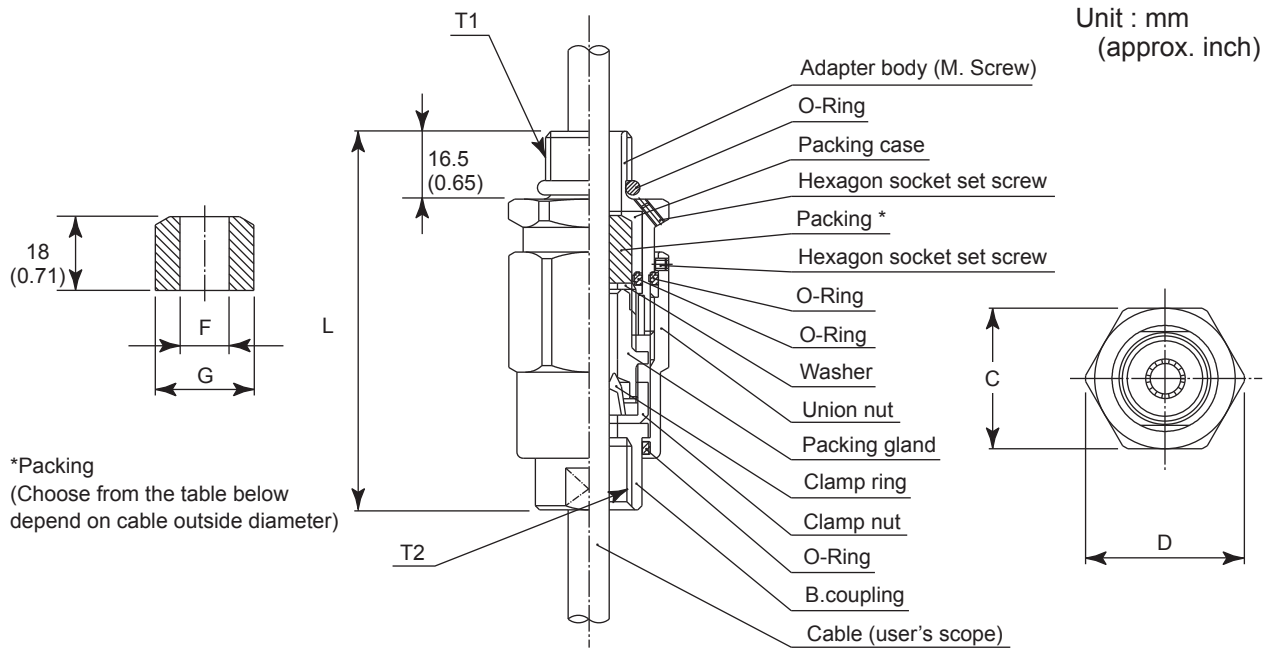

Size					Cable outer diameter	Packing dimensions		Identification mark	Weight kg (lb)
T1	T2	C	D	L		F	G		
G 1/2	G 1/2	35 (1.38)	39 (1.54)	94.5 (3.72)	ø8.0 to ø10.0 (ø0.31 to ø0.39)	ø10.0 (ø0.39)	ø20.0 (ø0.79)	16 8-10	0.26 (0.57)
					ø10.0 to ø12.0 (ø0.39 to ø0.47)	ø12.0 (ø0.47)		16 10-12	

■ OPERATING INSTRUCTIONS

Specify the following when ordering :

- a) Model and suffix codes.
- b) Sizing data: Mandatory for ordering.
Create the sizing data by using the latest digitalYEWFL0 Sizing Program.
- c) Selection of UPPER DISP. FLOWRATE
Except: the Remote Type Detector (-N)
- d) Tag No.:
Tag plate on the converter: up to 16 characters
Stainless Steel Tag Plate (/SCT): up to 30 characters
Software Tag:
BRAIN (-D): up to 16 characters
HART (-E or -J [HART 5]): up to 8 characters
HART (-J [HART 7]): up to 32 characters
Fieldbus (-F): up to 32 characters
- e) Multi-Variable Type Selection
- f) Final Destination Selection
- g) TIIS Flameproof Type for Inspection Carry-in Code.
- h) HART Protocol Revision:
For Output signal/Communication (Code: -J), specify HART 5 or HART 7.

===== RELATED INSTRUMENTS =====
SDBT Distributor Refer to 01B04T01-E
Refer to 01B04T02-E

===== RELATED MATERIAL =====
Model DY Vortex Flowmeter T1 1F6A0-01E
Model DY, DY A
FOUNDATION Fieldbus
Communication Type
Vortex FlowmeterGS 01F06F01-01EN

===== REFERENCE =====
'digitalYEWFL0', 'DY', 'DYA' and 'DYC' are registered trademarks of Yokogawa Electric Corporation.

Product names and company names in this document are trademarks or registered trademarks of the respective companies

In this document, trademarks or registered trademarks are not marked with "TM" or "®".