

PRODUCT RANGE



IMITT
IMIT CONTROL SYSTEM

IMIT: leader in thermoregulation for over a hundred years.

History

Since 1917, at IMIT we have always discussed solutions. We began with electromechanics, becoming the leaders in temperature regulation. We are constantly at the forefront of technology and have invested all the experience gained in millions of products installed in the best home appliances and in the most diverse appliances all over the world. While we have upheld the same principle since the dawn of our company: solutions, first of all.

Philosophy

The IMIT CONTROL SYSTEM philosophy has decided to take up the challenge: new products, absolute quality, immediate processes, with a careful and above all a concrete look at renewable energies.

There is no innovation without solid skills to start with.

Our products are the best that thermoregulation can offer: functionality and simplicity of use, integration and professionalism, design and energy saving.

Product quality

Using the skills acquired by the company, employees, suppliers and customers is the only one way to obtain a quality standard adapted to new technologies and the pressing demand for renewal.

The constant goal of the IMIT CONTROL SYSTEM is quality in all stages of production, as well as proposing the ideal solutions, guaranteeing the highest quality and respecting the deadlines agreed with customers.

Customer service

An excellent degree of efficiency may also be verified through the competence and organisation of customer service where the customer is able to find expert and reliable personnel. The IMIT CONTROL SYSTEM brings together the know-how of our long experience both in the electromechanical field and in the electronic field, including our customised industrial and civil solutions to make customised equipment for any need.

Our presence

Our IMIT CONTROL SYSTEM reaches over 1,000 customers all over the world. We have sales networks available in our different specialised market areas both for the Industry and the Distribution sectors.

We are also able to guarantee a qualified pre-sales and after-sales service, both for mechanical and electronic equipment.



Products

05



CLIMATE ADJUSTMENT AND SMART HOME

Room thermostats	p.06
Programmable thermostats	p.07
Smart Home	p.10
Built-in thermostats and chronothermostats	p.11
Fan-Coil regulators	p.13

15



INDUSTRIAL COMPONENTS AND THERMAL CENTRAL

Capillary thermoregulators	p.16
Capillary safety limiters	p.18
Thermometers, Pressure gauges, Manometers	p.19
Sensors, Actuators, Controls	p.21
Magnetic dirt separator	p.23
Boxed regulation and safety thermostats	p.24

29



SYSTEMS FOR RENEWABLE ENERGY SOURCES

Electronic regulators for fireplace, thermo-stove, thermo-heater	p.30
Hydraulic interfacing modules	p.31
Accessories for biomass systems	p.34

36

CUSTOM ELECTRONICS

CLIMATE ADJUSTMENT AND SMART HOME

Room thermostats

Programmable thermostats

Smart Home

Built-in thermostats and chronothermostats

Fan-Coil regulators



TA3 MECHANICAL WALL-MOUNTED THERMOSTAT

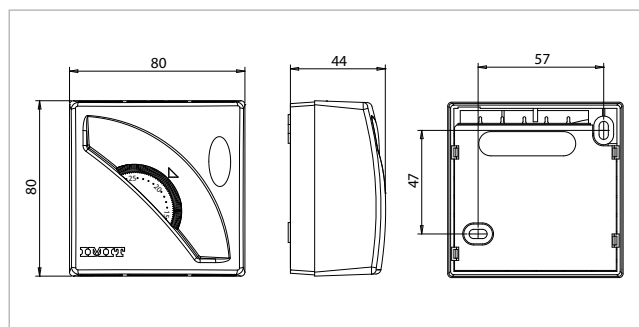

TA3 is a mechanical wall thermostat with saturated steam expansion tank, ideal for regulating home or office temperature. It is available in LED versions, without LED, ON / OFF (to turn off the thermostat without turning the knob), Summer / Winter (to connect and regulate the air conditioning or heating system). This thermostat also offers the possibility to limit or block the set temperature, through the installation of an optional switch under the cover.

Electrical contact capacity = 16(2,5) A / 250 Vac
 Regulation range = 5°±30°C
 Differential = 1K
 Insulation class = II
 Protection rating = IP20
 Max. tolerance temperature = 50°C
 Connection = 2 wires
 Output = changeover switches
 Operating mode: On/Off or Summer/Winter
 System: heating/air conditioning
 Certifications: CE, ENEC03, EAC

Code	Article	Description	Pack.
546070	TA3	3-contact thermostat	20
546030	TA3-A	3-contact thermostat-LED indicator light	20
546010	TA3-B	3-contact thermostat - LED indicator light - ON / OFF switch	20
546230	TA3-C	2-contact thermostat - LED indicator - summer winter switch	20
000071	SWITCH	Switch for knob lock	o.r.
004095	BOTTOM PIECES	Bottom pieces for TA3 in black	o.r.

TA5 MECHANICAL WALL-MOUNTED THERMOSTAT

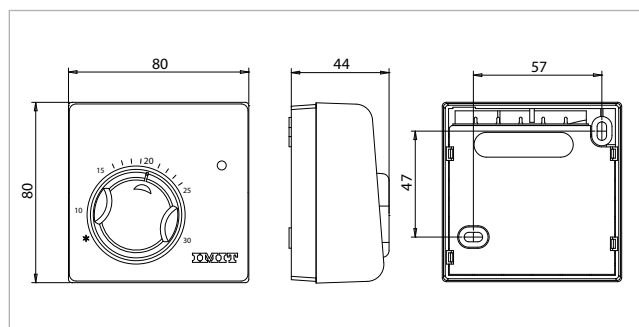

TA5 is a mechanical wall thermostat with saturated steam expansion tank, ideal for regulating home or office temperature. It is available in LED versions, without LED, ON / OFF (to turn off the thermostat without turning the knob), Summer / Winter (to connect and regulate the air conditioning or heating system). This thermostat also offers the possibility to limit or block the set temperature, through the installation of an optional switch under the cover. Thanks to the new external ergonomic knob, temperature regulation is simple and accessible to everyone.

Electrical contact capacity = 16(2,5) A / 250 Vac
 Regulation range = 5°±30°C
 Differential = 1K
 Insulation class = II
 Protection rating = IP20
 Max. tolerance temperature = 50°C
 Connection = 2 wires
 Output = changeover switches
 Operating mode: On/Off or Summer/Winter
 System: heating/air conditioning
 Certifications: CE, ENEC03, EAC

Code	Article	Description	Pack.
546770	TA5	3-contact thermostat	20
546730	TA5-A	3-contact thermostat-LED indicator light	20
546710	TA5-B	3-contact thermostat - LED indicator light - ON / OFF switch	20
546750	TA5-C	2-contact thermostat - LED indicator - summer winter switch	20
000071	SWITCH	Switch for knob lock	o.r.
004095	BOTTOM PIECES	Bottom pieces for TA5 in black	o.r.

TECHNO RT

DIGITAL WALL-MOUNTED THERMOSTAT

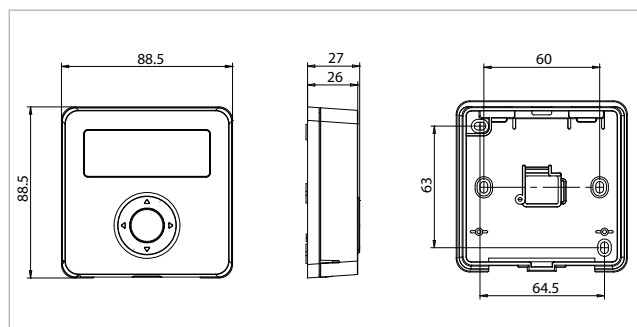

TECHNO RT is a simple and precise digital room thermostat. Measured room temperature, set time or temperature, status icons and low battery signal are clearly displayed on the large LCD display. You can set up the anti-freeze threshold and two temperature levels (comfort and reduced, day and night), and can regulate both the air conditioning and heating systems, through the three modes of operation Summer/Winter/Anti-freeze. It is ideal for small premises that do not require temperature programming or managing temperature variations in specific areas.

Electrical contact capacity = 5(1)A / 250 Vac
 Regulation range = 5°÷35°C
 Differential = 0,2K
 Thermometer resolution = 0,1°C
 Thermometer precision = ±0,3°C
 Max. room temperature = 50°C
 Insulation class = II
 Protection rating = IP20
 Options = 12h/24h clock and °C/°F selection
 Operating mode: Summer/Winter/Anti-freeze
 System: heating/air conditioning
 Certifications: CE, ENEC03, EAC

Code	Article	Description	Pack.
578120	TECHNO RT	Thermostat with AAA battery power supply	5
578122	TECHNO RT V	Thermostat with 230 Vac power supply	5
578124	TECHNO RT R	Thermostat with AAA batteries and TECHNO RCV Radio Receiver	5
578125	TECHNO RT VR	Thermostat with 230 Vac power supply and TECHNO RCV Radio Receiver	5

CHRONOMIX-S

DAILY WALL-MOUNTED CHRONOTHERMOSTAT

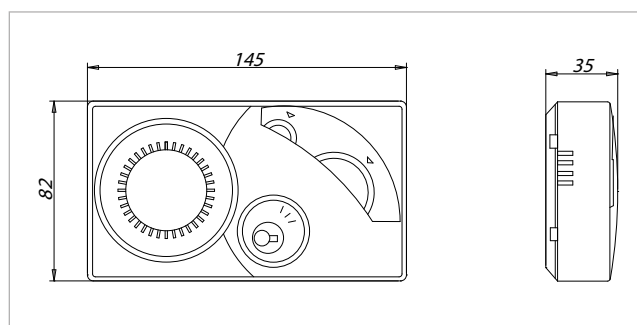

CHRONOMIX-S is an electronic daily programmable thermostat that is extremely simple and intuitive. Through a switch clock you may choose which one of the two levels of temperature to activate at a certain time. It is ideal for regulating home or office temperature, through the two knobs that manage comfort or reduced temperature, perfect for the regulation of different temperatures during the day and night or during your absence. Easy to set up, but highly technological, thanks to its TPI operation that allows exploiting thermal inertia in every type of environment, guaranteeing absolute comfort and energy and economic savings and an ErP contribution of 4%.

Electrical contact capacity = 5(1) A / 250 Vac
 Temperature range = 10°÷30°C
 Differential = 0.5 K
 Insulation class = II
 Protection rating = IP20
 Max. room temperature = 50°C
 Power supply = 2 x 1.5V-LR6 AA batteries
 Operating mode: Manual / Automatic
 Heating system
 Form of control: TPI (optional)
 Certifications = CE, ENEC03

Code	Article	Description	Pack.
578180	CHRONOMIX-S	Daily chronothermostat with switch clock	5

TECHNO DUO

DAILY WALL-MOUNTED CHRONOTHERMOSTAT

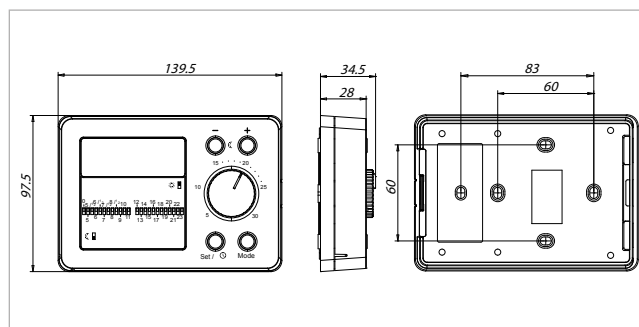

TECHNO DUO is a programmable electronic daily switch thermostat. The LCD display (backlit blue) shows the room temperature, set time or temperature, daily programming, active mode of operation and low battery indicator. The automatic program can be set to half an hour or an hour. It memorises the anti-freeze threshold and two temperature levels (comfort and reduced, day and night), and regulates both the air conditioning and heating systems, through the three modes of operation: Manual/Automatic/Anti-freeze. The TPI function (optional) allows exploiting thermal inertia in every type of environment, guaranteeing absolute comfort, and energy and economic savings and an ErP contribution of 4%. Ideal for those who want constant programming during the week or for those who have difficulty with technology.

Electrical contact capacity = 5(1) A / 250 Vac
 Regulation range = 5°±35°C
 N° of settable temperatures = 2
 Time slots = 0.5 h e 1 h
 Differential = 0,2 K
 Thermometer resolution = 0,1°C
 Thermometer precision = ±0,3°C
 Max. room temperature = 50°C
 Insulation class = II
 Protection rating = IP20
 Options = 12h/24h clock and °C/°F selection
 Operating mode: Manual/Automatic/Anti-freeze
 System: heating/air conditioning
 Form of control: TPI (optional)
 Certifications = CE, ENEC03

Code	Article	Description	Pack.
578160	TECHNO DUO	Daily chronothermostat with switch clock and LCD display.	5

TECHNO DPT

DAILY WALL-MOUNTED CHRONOTHERMOSTAT

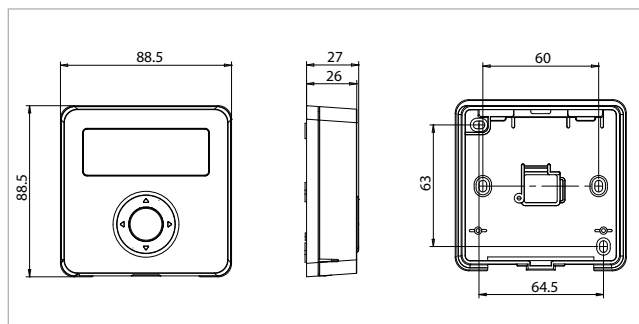

TECHNO DPT is a programmable digital daily programmable thermostat. The LCD display shows the measured temperature, set time or temperature, active mode of operation and digital switches based on the time programming in use (Automatic function). The program can be set in 1 hour intervals. It is possible to memorise the anti-freeze threshold and two temperature levels (comfort and reduced, day and night). It can regulate both the air conditioning and heating systems, through the three modes of manual operation (Comfort-Eco)/Automatic/Anti-freeze. It combines tradition and the future thanks to digital switches and is ideal for those who want to have a simple and constant programming during the week.

Electrical contact capacity = 5(1) A / 250 Vac
 Regulation range = 5°±35°C
 N° of settable temperatures = 2
 Time slots = 1 h
 Differential = 0,2 K
 Thermometer resolution = 0,1°C
 Thermometer precision = ±0,3°C
 Max. room temperature = 50°C
 Insulation class = II
 Protection rating = IP20
 Options = 12h/24h clock and °C/°F selection
 Operating mode: Manual/Automatic/Anti-freeze
 System: heating/air conditioning
 Certifications = CE, ENEC03, EAC

Code	Article	Description	Pack.
578121	TECHNO DPT	Daily chronothermostat powered by AAA batteries	5
578123	TECHNO DPT V	Daily chronothermostat with 230 Vac power supply	5
578126	TECHNO DPT R	Daily chronothermostat powered by AAA batteries and TECHNO RCV Radio Receiver	5
578127	TECHNO DPT VR	Daily chronothermostat with 230 Vac power supply and TECHNO RCV Radio Receiver	5

TECHNO WPT

WEEKLY WALL-MOUNTED PROGRAMMABLE CHRONOTHERMOSTAT

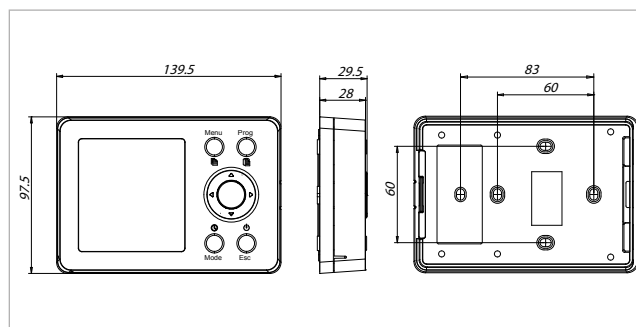
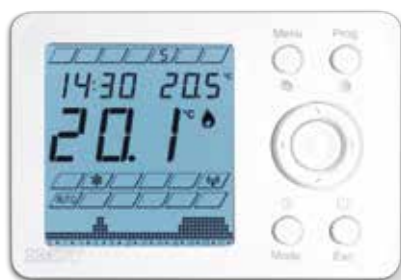

TECHNO WPT is a programmable digital weekly programmable thermostat with 3 temperatures set in 30-minute time slots. It can regulate both the air conditioning and heating systems. Thanks to the large blue backlit LCD display you can display the measured temperature, set temperature, time, active day of the week and mode of operation: Manual (Comfort-Eco)/Automatic/Anti-freeze. The buttons to increase/decrease parameters are always accessible. It is possible to install an external probe for underfloor heating systems. It is ideal for those with different habits depending on the day of the week or with environments that they use at different times of the day.

Electrical contact capacity = 5(1) A / 250Vac
 Regulation range = 5°±35°C
 N° of settable temperatures = 3
 Time slots = 0.5 h
 Differential = 0,2 K
 Thermometer resolution = 0,1°C
 Thermometer precision = ±0,3°C
 Max. room temperature = 50°C
 Insulation class = II
 Protection rating = IP20
 Options = 12h/24h clock and °C/°F selection
 Operating mode: Manual/Automatic/Anti-freeze
 System: heating/air conditioning
 Certifications = CE, ENEC03, EAC

Climate adjustment and smart home

Code	Article	Description	Pack.
578130	TECHNO WPT	Weekly chronothermostat with AA battery power supply	5
578131	TECHNO WPT V	Weekly chronothermostat with 230 Vac power supply	5
578148	TECHNO WPT R	Weekly chronothermostat with AA batteries and TECHNO RCV Radio Receiver	5
578149	TECHNO WPT VR	Weekly chronothermostat with 230 Vac power supply and TECHNO RCV Radio Receiver	5

WPTT H TOUCH

WEEKLY WALL-MOUNTED PROGRAMMABLE CHRONOTHERMOSTAT

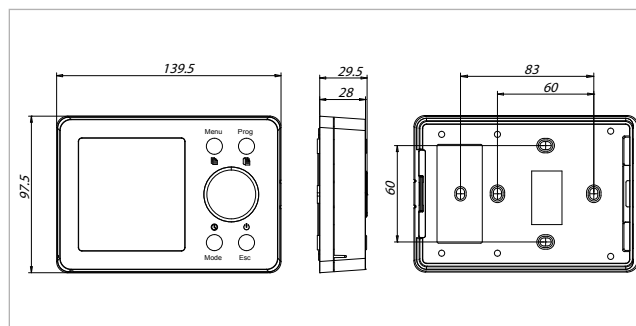

TECHNO WPTT H is a programmable digital weekly programmable thermostat with humidity detector, which can be set at 3 temperatures on 30-minute time slots. It can control both the air conditioning and heating systems. Thanks to the blue backlit LCD display it is possible to display the detected temperature, set temperature, time, active day of the week, humidity % and operating mode: Manual (Comfort-Eco) / Automatic / Antifreeze. All parameter controls (increment / decrement) are always accessible. An external probe can be installed for underfloor heating systems. Its touch front screen is designed for those looking for an appealing design.

Electrical contact capacity = 5(1) A / 250Vac
 Regulation range = 5°±35°C
 N° of settable temperatures = 3
 Time slots = 0.5 h
 Differential = 0,2 K
 Thermometer resolution = 0,1°C
 Thermometer precision = ±0,3°C
 Max. room temperature = 50°C
 Insulation class = II
 Protection rating = IP20
 Options = 12h/24h clock and °C/°F selection
 Operating mode: Manual/Automatic/Anti-freeze
 System: heating/air conditioning
 Certifications = CE, ENEC03, EAC

Code	Article	Description	Pack.
578139	TECHNO WPTT H	Weekly TOUCH chronothermostat with AA battery power supply	5
578140	TECHNO WPTT VH	Weekly TOUCH chronothermostat with 230 Vac power supply	5
578145	TECHNO WPTT RH	Weekly TOUCH chronothermostat with AA batteries and TECHNO RCV Radio Receiver	5
578146	TECHNO WPTT VRH	Weekly TOUCH chronothermostat with 230 Vac power supply and TECHNO RCV Radio Receiver	5

TECHNO APP SMART HOME



TECHNO APP is not just a WiFi thermostat but a truly simple and flexible smart home automation system. Thanks to the free smartphone app IMIT APP (available for Android and iOS) and the IMIT-BOX control gateway, you can set up the heating remotely or check home appliances and other electronic devices, such as an A/V system or even lighting. Regardless of what your starting need is, Techno App can be expanded as you please through smart plug and relay sockets, adding up to 100 wireless accessories to control the same number of devices.

Thanks to TECHNO APP you can improve your comfort through managing multiple chronothermostats to regulate the temperature of different areas, even on several floors, in homes and offices, without wiring; set the preferred time schedule, both for climate and home appliances, control consumption and save money, not waste energy, predict real electricity consumption with an estimate of costs and activate the system only when you are about to get home, thanks to the geolocation function.

Code	Article	Description	Pack.
578990	TECHNO APP KIT 1	Kit made up of IMITBOX gateway and Smart Thermostat	o.r.
578995	TECHNO APP KIT 2	Kit made up of IMITBOX, Smart Thermostat and Smart Relay	o.r.
578996	TECHNO APP KIT 3	Kit made up of IMITBOX and 2 Smart Thermostats	o.r.
578997	TECHNO APP KIT 4	Kit made up of IMITBOX, Smart Thermostat and Smart Plug	o.r.
578991	SMART RELAY	Smart relay to be associated with an existing TECHNO APP system	o.r.
578992	SMART PLUG	Smart electric socket to be associated with an existing TECHNO APP system	o.r.
578993	GATEWAY IMITBOX	Gateway for controlling up to 100 TECHNO APP devices	o.r.
578994	TERMSOTATO SMART	Smart thermostat to be associated with an existing TECHNO APP system	o.r.



TAE/503S

BUILT-IN ELECTRONIC ROOM THERMOSTAT



TAE / 503S is a DIN503 built-in room thermostat, ideal for regulating the temperature of your home or office. It can manage both the air conditioning and heating systems, and the three modes of Summer/Winter/Antifreeze operation may be set in a simple manner, thanks to the practical knob for regulating the temperature. It has a LED signal for low batteries, which is equipped with 4 interchangeable frames, to be used with most aesthetic-plates for switches on the market. It is ideal for small rooms, where it is not necessary to program the temperature or manage temperature variations in specific areas.

Electrical contact capacity = 8(5) A / 250 Vac
 Regulation range = $5^{\circ}\pm 30^{\circ}\text{C}$
 Power supply = 2 x 1.5V-LR6 AA batteries
 Max. room temperature = 50°C
 Insulation class = II
 Protection rating = IP40
 Operating mode: Summer/Winter/Anti-freeze
 System: heating/air conditioning
 Certifications = CE

Code	Article	Description	Pack.
560065	TAE/503S	Built-in room thermostat, AA battery power supply	10

DUO/503S

BUILT-IN DAILY CHRONOTHERMOSTAT



DUO / 503S is a built-in programmable DIN503 thermostat with switches. It is ideal for regulating the temperature of the home or office and can manage both the air conditioning system and heating systems. Thanks to the backlit LCD display you can display the measured temperature, set temperature, time and the active mode of operation: Manual/Automatic/Anti-freeze. Time programming at 1 hour intervals is carried out via the practical mechanical switches. It is ideal for those who want to have simple and constant programming during the week or for those who have difficulty with technology.

Electrical contact capacity = 8(5) A / 250 Vac
 Regulation range = $5^{\circ}\pm 35^{\circ}\text{C}$
 Power supply = 2 x 1.5V-LR6 AA batteries
 N° of settable temperatures = 2
 Time slots = 1 h
 Thermometer precision = $\pm 0,3^{\circ}\text{C}$
 Max. room temperature = 50°C
 Insulation class = II
 Protection rating = IP40
 Operating mode: Manual/Automatic/Anti-freeze
 System: heating/air conditioning
 Certifications = CE

Code	Article	Description	Pack.
560075	DUO/503S	Daily built-in chronothermostat, AA battery power supply	10

CRD/503S BUILT-IN WEEKLY CHRONOTHERMOSTAT



CRD/503S is a programmable built-in weekly programmable thermostat DIN503 with three programmable temperatures at intervals of 1 hour. It is ideal for managing the temperature of your home or office and can regulate both the air conditioning and heating systems. Thanks to the backlit LCD display you can display the measured temperature, set temperature, time, active day and the operating mode: Manual/Automatic/Anti-freeze.

It is ideal for those with different habits depending on the day of the week or for those who have environments that they use at different times of the day.

Electrical contact capacity = 8(5) A / 250 Vac
 Regulation range = 5°-35°C
 Power supply = 2 x 1.5V-LR6 AA batteries
 N° of settable temperatures = 3
 Time slots = 1 h
 Thermometer precision = ±0,3°C
 Max. room temperature = 50°C
 Insulation class = II
 Protection rating = IP40
 Operating mode: Manual/Automatic/Anti-freeze
 System: heating/air conditioning
 Certifications = CE

Code	Article	Description	Pack.
560085	CRD/503S	Weekly built-in chronothermostat, AA battery power supply	10

ACCESSORIES FOR BUILT-IN THERMOSTATS



Kit of aesthetic-plates for built-in DIN503, glossy black colour.

Code	Article	Description	Pack.
557022	PLATES KIT	Set of 5 glossy black aesthetic-plates	o.r.

FRAME COMPATIBILITY WITH PLATES

FRAME A COMPATIBILITY	FRAME B COMPATIBILITY	FRAME C COMPATIBILITY	FRAME D COMPATIBILITY
IMIT Bticino light, light tech, living international, matix. Vimar Idea, Idea Rondò. Gewiss Playbus, Playbus young. Ave Banquise, Sistema 45, Noir. Siemens Delta futura Legrand Ergo, Cross, Vela.	Bticino Luna, Axolute. Vimar Plana, Eikon. Gewiss Chorus. Master Modo, Mix.	Bticino Living light air, Axolute Air.	Ave sistema 44. Vimar Archè. Electrocanali Prestige,Life.

FAN TA3

MECHANICAL REGULATOR FOR FAN-COIL

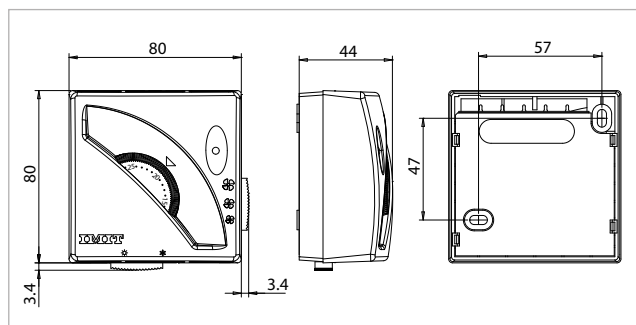

FAN TA3 SE is an electromechanical steam expansion regulator for fan-coils, radiators and fan convectors. It is ideal for regulating home or office temperature in its two modes of operation: Summer/Winter (to activate the air conditioning or heating functions). It is also equipped with a mechanical three-position switch for regulating fan speeds and to control the hot/cold valve.

Power supply = 230 Vac
 Regulation range = $7^{\circ}\pm 30^{\circ}\text{C}$
 Differential = 1 K
 Thermostat contact capacity = 16(2,5) A / 250 Vac
 Selector switch capacity = 10(2) A / 250 Vac
 Output = changeover switches
 Installation = wall
 Operating mode: Summer/Winter/Anti-freeze
 System: fan-coil/radiators/fan convectors
 Certifications = CE, ENEC03, EAC

Code	Article	Description	Pack.
548501	FAN TA3 SE	Room thermostat for FAN-COIL	20

FAN 503

FAN-COIL REGULATOR



FAN 503 is an electronic built-in DIN503 regulator for fan coils, radiators and fan convectors with LCD display. It includes three relays to regulate the fan speed and two relays to control the solenoid valves and the water probe inlet (NTC 10K probe included in the package).

Power supply = 230 Vac
 Temperature regulation range = $5^{\circ}\pm 35^{\circ}\text{C}$
 Room temperature display = $0^{\circ}\pm 40^{\circ}\text{C}$ (resolution 0,1°C)
 Differential = 0,5 K
 Protection rating = IP20 (with installed product)
 Output = free contact relay
 Electrical contact capacity = 3 A / 250 V~
 Max. service temperature = 50°C
 Installation = built-in
 Operating mode: Summer/Winter/Anti-freeze
 System: fan-coil/radiators/fan convectors
 Certifications = CE, ENEC03

Code	Article	Description	Pack.
578305	FAN 503	Electronic built-in regulator for FAN COIL	5

ACCESSORIES FOR FAN 503

Aesthetic-plates and frame for built-in DIN503 for Bticino Living International, Gewiss Playbus and Playbus Young, Vimar Idea and Rondò, IMIT. Glossy black colour.

Code	Article	Description	Pack.
076410	FRAME 503	Frame for DIN 503 box	o.r.
557022	PLATES KIT	Set of 5 glossy black aesthetic-plates	o.r.

INDUSTRIAL COMPONENTS AND THERMAL CENTRAL

Capillary thermoregulators

Capillary safety limiters

Thermometers, Pressure gauges, Manometers

Sensors, Actuators, Controls

Magnetic dirt separator

Boxed regulation and safety thermostats

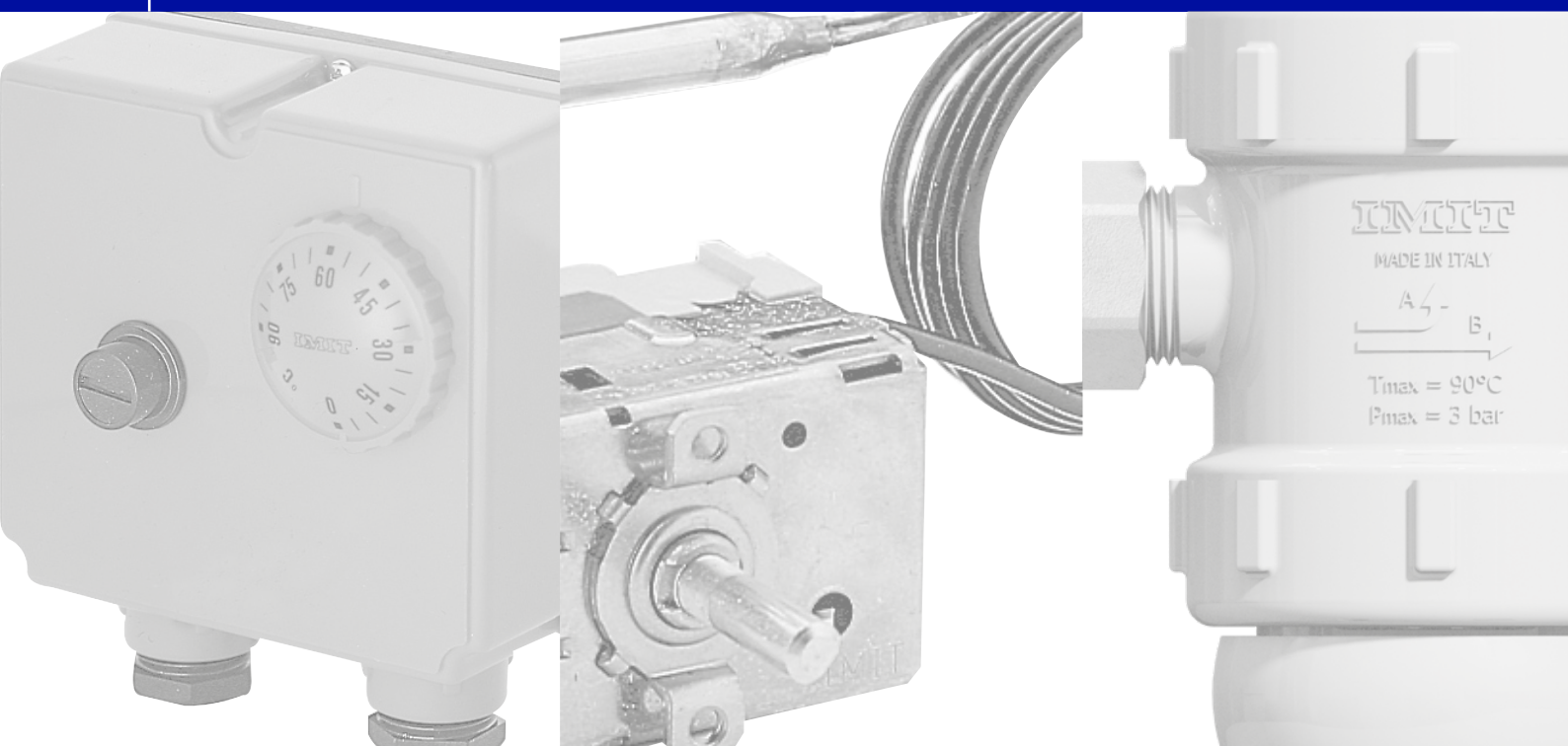

TR2 CAPILLARY REGULATION THERMOSTAT

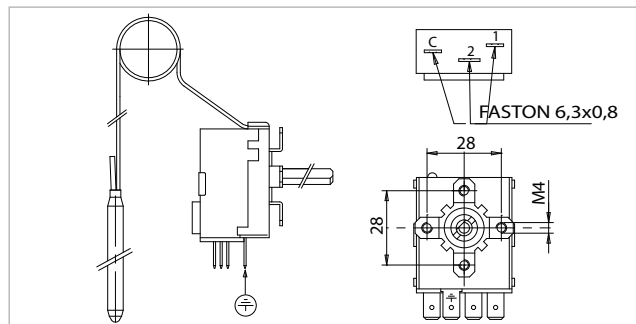

TR2 is a liquid expansion capillary thermostat, unipolar, with changeover switches, particularly suitable for automatic temperature regulation for appliances in the field of civil and industrial heating, air conditioning and household appliances such as boilers, washing machines, dishwashers, etc.

Electrical contact capacity = NC 16(6) / A 250 Vac
 Switches = changeover
 Max. head temperature = 85°C
 Min. capillary curvature radius = 5 mm
 Connection = via faston 6,3x0,8
 Certifications = CE, ENEC03, EAC, UL, CSA

Code	Article	Adjustable temperature °C	Capillary length mm	Bulb size mm	Pack.
540010	TR2 INAIL	0/+90	1000	6.5*95	100
540355	TR2 INAIL	0/+90	1500 PVC	6.5*95	100
541307	TR2 INAIL CUTTING SCREW	0/+90	1500	6.5*95	100
540043	TR2	-30/+35	1000	6*215	100
540030	TR2	0/+40	1000	9.5*92	100
540160	TR2	0/+120	1000	6.5*95	100
540673	TR2	0/+120	1500	7*90 M14*1	100
540140	TR2	+70/+210	1000	5*125	100
540020	TR2	+50/+300	1000	3.5*195	100

KIT TR2 CAPILLARY REGULATION THERMOSTAT



KIT TR2 includes a TR2 with adjustable temperature range 0 to 90°C, capillary 1500 PVC, INAIL certified, complete with knob and dial.

Code	Article	Description	Pack.
5R0359	KIT TR2	Single package with TR2, Knob and dial	10

TRZ 2-STAGE CAPILLARY REGULATION THERMOSTAT

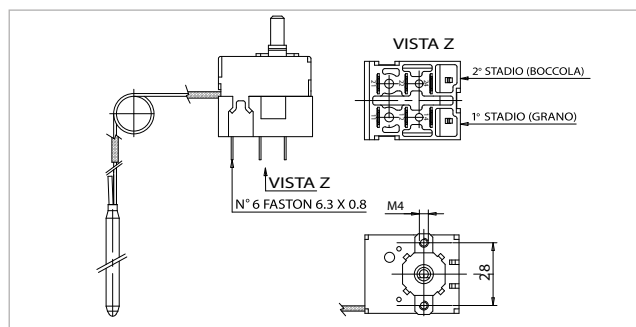

TRZ is a capillary thermostat with liquid expansion probe and 2-stage switch, unipolar, with switching contacts, particularly suitable for automatic temperature regulation for applications in civil and industrial heating, air conditioning and household appliances such as radiators electric, boilers, washing machines, dish-washers, etc.

Electrical contact capacity = 15 (2,5) A / 250 Vac
 Switches = changeover
 Max. head temperature = 80°C
 Capillary length = 1500 mm PVC
 Min. capillary curvature radius = 5 mm
 Connection = via faston
 Certifications = CE, ENEC03, EAC

Code	Article	Description	Pack.
544024	TRZ	2-stage thermostat: 1st stage 40/78°C, second stage 47/85°C	25

ACCESSORIES FOR TR2 AND TRZ



Knobs are designed according to the need for regulation and the support dials.

Code	Article	Description	Pack.
556301	KNOB	Knob 0/90°C	20
556302	KNOB	Knob with an arrow	20
556303	KNOB	Knob 0/120°C	20
556313	KNOB	Knob 70/210°C	20
556326	KNOB	Knob 50/300°C	20
556343	KNOB	Knob 0/40°C	20
556360	KNOB	Knob -30/+30°C	20
556501	DIAL	Chrome dial	20
556503	DIAL	Black dial	20
556978	SPRING	Spring for knob	20
556979	STILL	Knob latch	20

LS1/LS3 CAPILLARY SECURITY LIMITERS

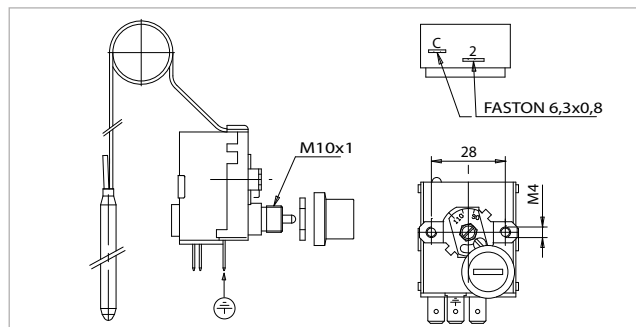

LS1 / LS3 is a capillary thermostat with a liquid expansion probe, unipolar, with safety temperature limiter with manual or automatic reset and with positive safety in case of capillary breakage. It is particularly suitable for boilers, heating systems and in all those appliances where it is necessary not to exceed a maximum set temperature.

Switches = interrupted due to temperature increase
 Max. head temperature = 85°C
 Copper bulb = 125°C
 Copper bulb = Ø 6,5 x 95 mm
 Min. capillary curvature radius = 5 mm
 Certifications = CE, ENEC03, EAC, UL, CSA

Code	Article	Temperature °C	Capillary length mm	Electrical contact capacity	Reset	Pack.
541510	LS1	+90/+110	1000	16(6) A/ 250 V~	MANUAL	100
541550	LS1 INAIL	+100	1000	16(6) A/ 250 V~	MANUAL	100
541563	LS1 INAIL	+100	1500 PVC	16(6) A/ 250 V~	MANUAL	100
541750	LS3	+100	1000	100mv 0.3A cc	AUTOMATIC	100
541752	LS3	+100	1000	100mv 0.3A cc	AUTOMATIC	100

Industrial components and thermal central

KIT LS1 CAPILLARY SECURITY LIMITERS



KIT LS1 includes a LS1 100° C with capillary 1500 PVC, INAIL certified, with manual reset, complete with cap and stop.

Code	Article	Description	Pack.
5R1569	KIT LS1	Single package with LS1, Cap and stop	10

THERMOMETERS CAPILLARY



Range of thermometers with liquid expansion probe, particularly suitable for appliance on boilers, refrigerators, catering appliances, home appliances. The thermometers are available with different measurement ranges, shapes, designs and customisable colours.

Casing = plastic
Max. body temperature = 70°C
Certifications = CE, EAC

Code	Article	Description	Pack.
010247	THERMOMETER	Circular thermometer 0/120°C, Ø 52mm, Capillary 1500mm PVC, black casing, white typeface, black screen	50
060107	THERMOMETER	Circular thermometer 0/120°C, Ø 37mm, Capillary 1500mm PVC, black casing, black typeface, white screen	50
013451	THERMOMETER	Square thermometer 0/120°C, Frame 54*54mm Built-in Ø52mm, Capillary 1500mm PVC, black casing, white typeface, black screen	50
042101	THERMOMETER	Square thermometer 0/120°C, Frame 48*48mm, Capillary 1000mm PVC, black casing, white typeface, black screen	50
021968	THERMOMETER	Rectangular thermometer 10/105°C, 58 *25mm, capillary 1500mm PVC. Black casing, black typeface, white screen	50
010836	THERMOMETER	Circular thermometer 50/350°C, Ø 52mm, Capillary 1000mm, black casing, white typeface, black screen	50

MANOMETERS CAPILLARY



Range of manometers with capillary connection, particularly suitable for appliance on boilers, fireplaces, heaters and home appliances. Pressure gauges are available with different measuring ranges, shapes, designs and customisable colours.

Working range = 0/6 bar
Casing = plastic
Max. body temperature = 70°C
Certifications = CE, EAC

Code	Article	Description	Pack.
035553	MANOMETER	Circular manometer 0/6 bar, Ø 52mm, Capillary 1500 PVC, M14*1 fitting, black casing, white typeface, black screen	50
066226	MANOMETER	Circular manometer 0/6 bar, Ø 37mm, Capillary 1500 PVC, G1/4" connection, black casing, black typeface, white screen	50
036660	MANOMETER	Square manometer 0/6 bar, Frame 55*55mm, Built-in Ø52mm, Capillary 1500mm PVC, M14*1 fitting, black casing, white typeface, black screen	50

THERMOMANOMETER CAPILLARY



Range of liquid expansion thermomanometers and connection for manometer. Particularly suitable for appliance on boilers, fireplaces, heaters and home appliances. Available in a round version with different measuring ranges and colours (customisable typeface and dials).

Working range = 0/120°C - 0/6 bar
 Casing = plastic
 Max. body temperature = 70°C
 Certifications = CE, EAC

Code	Article	Description	Pack.
030646	THERMOMANOMETER	Thermomanometer 0/120°C 0/6 bar, Ø 52mm, Capillary 1500 PVC, M14*1 fitting, black casing, white typeface, black screen	50

POCKETS AND ACCESSORIES FOR TR2 AND LS THERMOSTATS, THERMOMETERS, PRESSURE GAUGES, MANOMETERS

Pockets for the immersion of TR2 and LS thermostats, fittings and tie-rods for coupling to different types of connection and check valves.

Code	Article	Description	Pack.
555001	POCKET	Pocket Ø 7*8 mm - L=50 mm - G1/2"	20
555002	POCKET	Pocket Ø 7*8 mm - L=100 mm - G1/2"	20
555004	POCKET	Pocket Ø 7*8 mm - L=120 mm - G1/2"	20
555012	POCKET	Pocket Ø 15*16 mm - L=100 mm contour - G1/2"	20
555014	POCKET	Pocket Ø 15*16 mm - L=120 mm contour - G1/2"	20
555027	POCKET	Pocket Ø 7*8 mm - L=200 mm - G1/2"	20
555034	POCKET	Pocket Ø 15*16 mm - L=100 mm - G1/2"	20
555035	POCKET	Pocket Ø 15*16 mm - L=120 mm - G1/2"	20
556554	SPRING	Pocket spring 15*16	o.r.
556557	SPRING	External spring	o.r.
556559	SPRING	Pocket spring 7*8	o.r.
501576	BRACKET	Bracket for thermometers and manometers Ø 52mm	o.r.
501578	LATCH	Latch for M4 tie rod	o.r.
501579	LATCH	Latch for M6 tie rod	o.r.
001565	RETENTION VALVE	M14*1 - G1/2" valve	o.r.
001566	RETENTION VALVE	G1/4"- G1/2" valve	o.r.
001567	RETENTION VALVE	G1/4" - G1/4" valve	o.r.
557205	ADAPTER	G1/4" manometer adapter	o.r.
557206	ADAPTER	M14*1 manometer adapter	o.r.

FLOW SWITCHES



Range of flow switches to measure the water flow in the conduit. Available models suitable for horizontal or vertical installation. Especially suitable for boilers and all appliances where flow control is necessary.

Fluid = Water and non-aggressive fluids
 Max pressure = 10 bar
 Max. fluid temperature = 95°C
 Electrical contact capacity = 50 VA
 Max. switching current: AC 0.2 A
 Max. switching voltage: AC 300 V
 Certifications = CE

Code	Article	Description	Pack.
561015	AFS42	Flow switch in composite material, G1/2" connections, Flow rate 1.7 l/min	10
561057	AFS40	Nylon 1/2" Flowswitch, Q=1.7 l/min, L=65 mm	10

TRANSDUCERS AND PRESSURE SWITCHES



The pressure transducer consists of a Hall effect sensor that obtains an electrical signal proportional to the applied pressure. The pressure switch consists of a sensitive stainless steel element, for direct operation of a micro-switch for actuators or signalling devices. Transducers and pressure switches are generally installed in boilers and in appliances that need a pressure check.

Fluid = Water and non-aggressive fluids
 Max pressure = 10 bar
 Max. fluid temperature = 110°C
 Electrical contact capacity = 50 VA
 Certifications = CE

Code	Article	Description	Pack.
561336	TP-1	Pressure transducer 0/4 bar, 5V DC power supply, Output signal 0.5-3.5V, G1/4" connections with O-ring	20
561338	TP-1	Pressure transducer 0/4 bar, 5V DC power supply, Output signal 0.5-3.5V, G3/8" connections with O-ring	20
561334	PRS-1	Falling pressure switch 0.5 bar, G1/4" connections with O-ring	20

MGR PLUG-IN THERMOSTAT



Plug-in thermostat particularly suitable for electric boilers

Code	Article	Description	Pack.
554760	MGR	Plug-in thermostat 10/80°C Boom L = 280mm	50

ARMORED COPPER RESISTANCE



Copper resistors particularly suitable for boilers

Code	Article	Description	Pack.
550670	RESISTANCE	Threaded copper resistance G1 1/4 " 1200W 230V	50
550680	RESISTANCE	Threaded copper resistance G1 1/4 " 1500W 230V	50
550200	RESISTANCE	Threaded copper resistance G1 1/4 " 2000W 230V	50

BC42 BIMETALLIC THERMOSTAT



Contact thermostat particularly suitable for fan convectors and fan heaters.

Code	Article	Description	Pack.
557500	BC42	Contact micro-switch, closing temperature $42\text{ }^{\circ}\text{C} \pm 3.5\text{ }^{\circ}\text{C}$ - opening temperature $32\text{ }^{\circ}\text{C} \pm 3.5\text{ }^{\circ}\text{C}$. - Connection clamps and stainless steel fixing spring.	10

STORM MAGNETIC UNDER-BOILER DIRT SEPARATOR

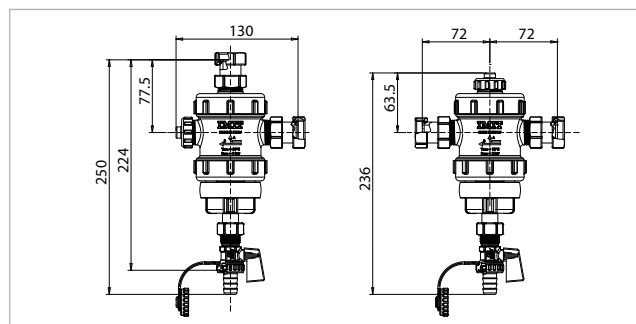

STORM is a cyclonic technology magnetic dirt separator with double magnet. Thanks to its 2 separation chambers, it retains all ferrous and non-ferrous particles that are harmful to the domestic boiler. May be installed as a part of a unit or directly, complete with fixing nozzles and dirt drain tap.

Max pressure = 3 bar
 Max. temperature = $0 \div 90\text{ }^{\circ}\text{C}$
 Compatible fluids = Water and non-aggressive fluids
 Connections: G3/4" ISO228/1 female swivel captive nut
 hose fitting $\varnothing 15\text{ mm}$
 Certifications = CE

Code	Article	Description	Pack.
563000	STORM	Magnetic under-boiler dirt separator	4

TC2 REGULATION THERMOSTAT IN IP40 CONTAINER

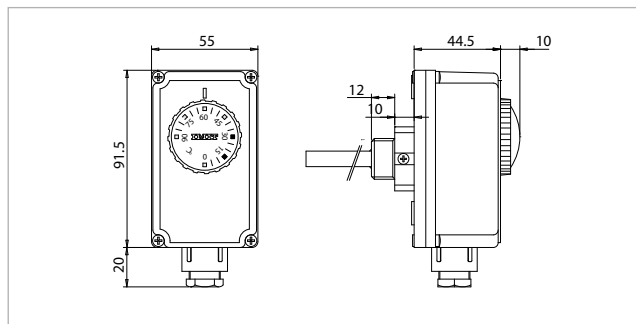

TC2 is a boxed immersion thermostat with liquid expansion, unipolar, with changeover switches, complete with a watertight protection pocket. The thermostat normally applied on delivery piping is particularly suitable for the automatic regulation of boilers, pumps and other various appliances. It is also available in a capillary version.

Electrical contact capacity = 10(2,5) A / 250 Vac
 Switches = interrupted due to temperature increase or exchange
 Max. head temperature = 80°C
 Max. bulb temperature = 125°C
 Thermal gradient = 1°K/min
 Protection rating = IP40
 Certifications = CE, ENEC03, DIN, PED, EAC

Code	Article	Description	Pack.
5R2470	TC2 INAIL	Adjustable thermostat 0/90°C, Pocket G1/2" L=100	10
542425	TC2 INAIL	Adjustable thermostat 0/90°C, Pocket G1/2" L=200	10
542441	TC2	Adjustable thermostat 40/210°C, Pocket G1/2" L=100	10
542440	TC2	Adjustable thermostat 40/210°C, Pocket G1/2" L=200	10
542562	TC2 INAIL	Adjustable thermostat 0/90°C, Capillary L=1000	10

LSC1 SAFETY LIMITER IN IP40 CONTAINER

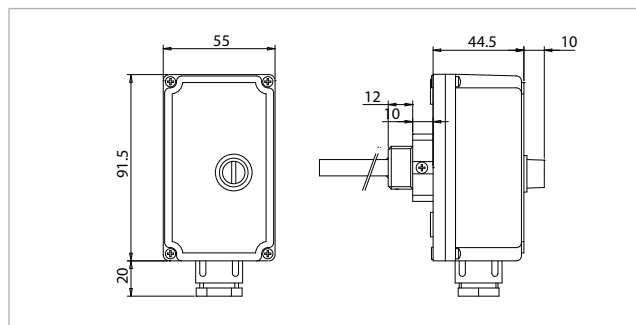
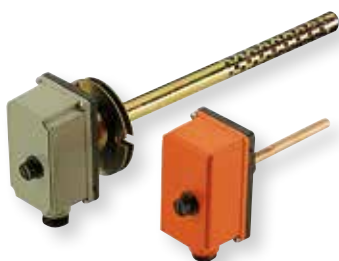

LSC1 is a boxed immersion thermostat, with liquid expansion probe, unipolar, safety temperature limiter with manual reset, fail-safe for capillary breakage, complete with watertight protection pocket. Useful in appliances where safety is required due to the temperature increase.

Electrical contact capacity = 10(2,5) A / 250 Vac
 Switches = interrupted due to temperature increase
 Thermal gradient = 1°K/min
 Max. head temperature = 80°C
 Max. bulb temperature = 125°C
 Protection rating = IP40
 Certifications = CE, ENEC03, DIN, PED, EAC

Code	Article	Description	Pack.
543010	LSC1	Safety thermostat 90/110°C, Pocket G1/2" L=120 Manual reset	10
543031	LSC1 INAIL	Safety thermostat 100°C, Pocket G1/2" L=100 Manual reset	10
543151	LSC1	Safety thermostat 90/110°C, Perforated pocket G1/2" L=280 Manual reset	20

TLSC REGULATION AND SAFETY BI-THERMOSTAT IN IP40 CONTAINER

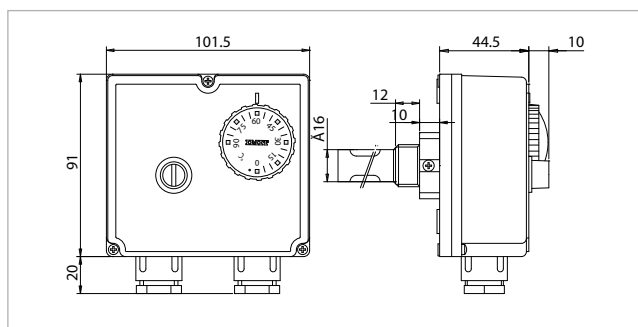

TLSC is a double boxed immersion thermostat, with liquid expansion probes, unipolar, temperature regulator and temperature limiter, fail-safe for capillary breakage, complete with watertight protection pocket. Particularly suitable for appliances where temperature control and safety is required.

Electrical contact capacity = 10 (2,5) A / 250 Vac
 Switches = interrupted due to temperature increase or exchange
 Max. head temperature = 80°C
 Max. bulb temperature = 125°C
 Thermal gradient = 1°K/min
 Protection rating = IP40
 Certifications = CE, ENEC03, DIN, PED, EAC

Code	Article	Description	Pack.
5R2714	TLSC INAIL	Bi-thermostat regulation 0/90°C, safety 90/110°C, Pocket G1/2" L=100	5
5R2731	TLSC INAIL	Bi-thermostat regulation 0/90°C, safety 100°C, G1/2" L=100 pocket	5

BRC CONTACT THERMOSTAT

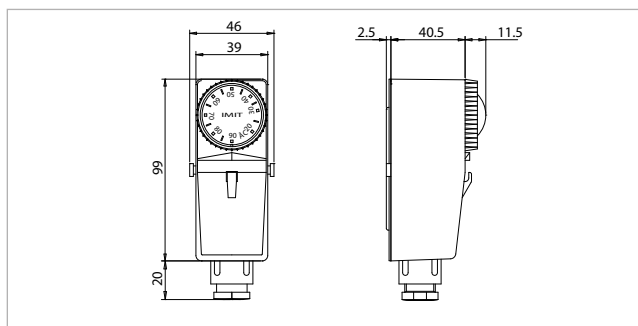

BRC is a bimetallic boxed thermostat, unipolar, with interrupted or changeover switches. Especially suitable for measuring and regulating temperature

Differential = 8±3K
 Electrical contact capacity = 16(2,5) A / 250 Vac
 Thermal gradient = 1°K/min.
 Max. head temperature = 80°C
 Protection rating = IP20
 Certifications = CE, ENEC03, EAC

Code	Article	Description	Pack.
5R5610	BRC	Bimetallic contact thermostat 20/90°C	20
5R5860	BRC	Bimetallic contact thermostat 20/90°C internal regulation	20

Industrial components and thermal central

TCR REGULATION THERMOSTAT IN IP40 CONTAINER

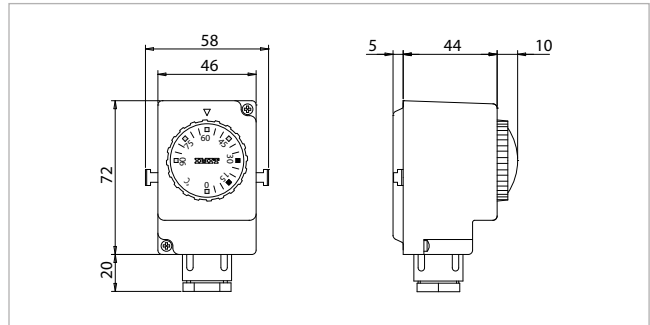

TCR is a liquid expansion boxed thermostat, unipolar, with interrupted or changeover switches, for contact appliances. Particularly suitable for measuring and regulating temperature.

Differential = $10 \pm 3K$
 Max. head temperature = $55^{\circ}C$
 Protection rating = IP40
 Electrical contact capacity = 10(2,5) A / 250 Vac
 Protection rating = IP40
 Certifications = CE, ENEC03, EAC

Code	Article	Description	Pack.
543451	TCR	Liquid expansion contact thermostat 20/90°C	20

Industrial components and thermal central

TCS ADJUSTABLE SAFETY LIMITER IN IP40 CONTAINER

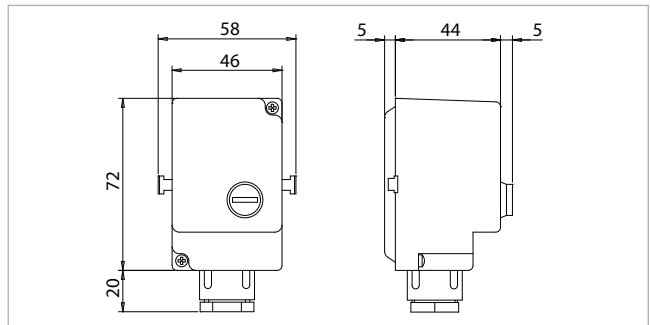

TCS adjustable safety limiter in Ip40 container TCS is a liquid expansion boxed safety thermostat, unipolar, with interrupted contacts. Especially suitable for appliances and for securing temperature.

Temperature limiter pre-regulation = $60^{\circ}C$
 Regulation range = $40^{\circ} \div 70^{\circ}C$
 Tolerance = 0-10K
 Manual reset
 Reset temperature = $-25K \pm 8K$ range
 Max. head temperature = $55^{\circ}C$
 Electrical contact capacity = C-1: 0,5 A / 250 Vac C-2: 10(2,5) A / 250 Vac
 Protection rating = IP40
 Certifications = CE, ENEC03, EAC

Code	Article	Description	Pack.
543454	TCS	Safety liquid expansion contact thermostat 40/70°C	20

TTCA REGULATION BI-THERMOSTAT IN IP40 CONTAINER

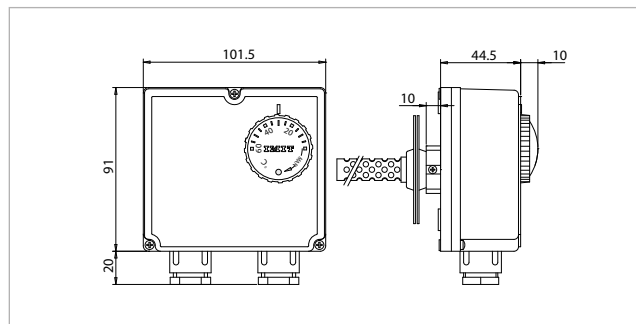

TTCA is a double regulation thermostat for burner control (internal regulation) and fan start or stop (external regulation).

Electrical contact capacity = 10 (2,5) A / 250 Vac
 Adjustable temperature FAN = 0°/60°C
 Internal adjustable temperature LIM = 30°/120°C
 Protection rating = IP40
 Max. head temperature = 80°C
 Max. bulb temperature = 150°C
 Certifications = CE, ENEC03, EAC

Code	Article	Description	Pack.
542860	TTCA	Ext. regulation thermostat 0/60°C, int. regulation 30/120°C, with perforated pocket 16*120mm	5
542870	TTCA	Ext. regulation thermostat 0/60°C, int. regulation 30/120°C, with perforated pocket 16*280mm	5
542873	TTCA	Ext. regulation thermostat 0/60°C, int. regulation 30/120°C, with 12*280mm boom pocket	5
542833	TTCA	Ext./int. regulation thermostat 0/90°C, with perforated pocket 15*16*100mm	5

ETR/ESL REGULATION THERMOSTAT IN IP54 CONTAINER

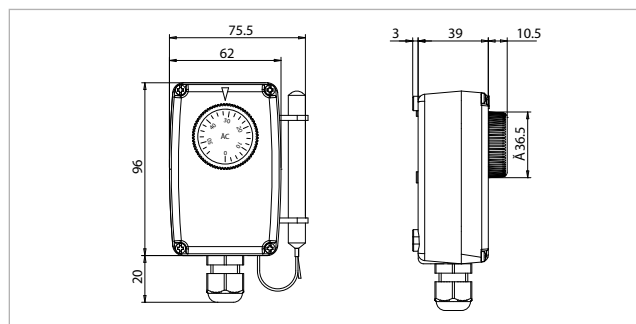

ETR is an adjustable boxed thermostat for controlling temperature in various appliances, especially suitable for environments with a high degree of pollution. Protection rating IP54.

Differential = from 3 to 6°C
 Electrical contact capacity = 16(2,5) A / 250 Vac
 Max. operating temperature = 65°C
 Protection rating = IP54
 Certifications = CE, ENEC03, EAC

Code	Article	Description	Pack.
544400	ETR	Regulation thermostat 0/55°C with joined nickel-plated bulb 9.5*92mm	5
544401	ETR	Regulation thermostat -35/+35°C with joined nickel-plated bulb 9.5*92mm	5
544402	ETR	Regulation thermostat -35/+35°C with 2000mm nickel-plated capillary	5
544406	ESL	Regulation thermostat 0/90°C with pocket L=100mm	5
008755	ACCESSORIES	Kit for mounting on DIN rail	o.r.

Industrial components and thermal central

ERT/TA ROOM THERMOSTAT IN IP40-IP54 CONTAINER

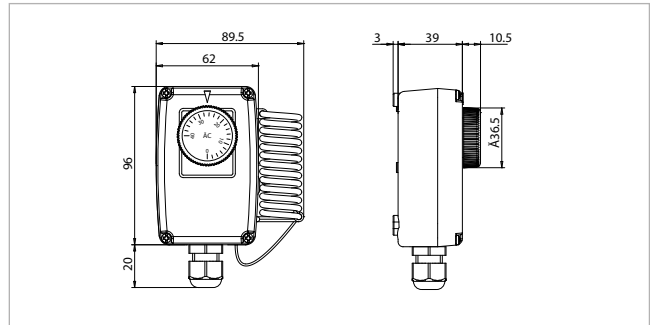

ERT/TA is an adjustable boxed thermostat for controlling the temperature in various appliances, particularly suitable for environments with a high degree of pollution.

Differential = from 1.5 to 3°C
 Electrical contact capacity = 16(2,5) A / 250 Vac
 Max. operating temperature = 65°C
 Protection rating = IP54 / IP40
 Certifications = CE, ENEC03, EAC

Code	Article	Description	Pack.
544404	ERT	Thermostat, watertight 0/40°C, joined IP54 Spiral sensor	5
544405	ERT	Thermostat, watertight -5/+35°C, joined IP54 Spiral sensor	5
544610	TA	Thermostat, watertight 0/40°C, joined IP40 Spiral sensor	20

TAE/S ELECTRONIC ROOM THERMOSTAT IN IP54 CONTAINER



TAE/S is an electronic room thermostat in a watertight container, with integrated circuits with an NTC temperature sensor with a high degree of sensitivity. Provided with 2 operating LEDs: red (heating in operation), green (power supply). Suitable especially for damp and dusty environments such as greenhouses, industrial sheds, etc.

Power supply = 230 Vac / 50Hz
 Regulation range = -5°/+35°C
 Temperature sensor = NTC
 Differential = 1K
 Operating temperature = -10°/+60°C
 Operating humidity = 10/90%
 Switches = changeover
 Electrical contact capacity = 6(1) A / 250 Vac
 Protection rating = IP54
 Probe length = 1,5m
 Certifications = CE, ENEC03, EAC

Code	Article	Description	Pack.
560051	TAE/S	Watertight electronic thermostat -5/+35°C	5
556602	PROBE	Spare probe	o.r.

SYSTEMS FOR RENEWABLE ENERGY SOURCES

Electronic regulators for fireplace, thermo-stove, thermo-heater

Hydraulic interfacing modules

Accessories for biomass systems



IMIT
IMIT CONTROL SYSTEM

FIRE WATER HID SIMPLE

REGULATOR FOR HYDRO FIREPLACES/
KITCHENS AND THERMOSTUPS



FIRE WATER HID SIMPLE is a DIN503 built-in electronic regulator for fireplaces, compact, with an attractive design adaptable to each installation environment. It can control a water heating system circulator thanks to its microprocessor logic. It can also control the manual activation of a "grill" rotisserie motor. Complete with probe immersion, electrical box and black aesthetic plate.

Power supply = 230 Vac / 50 Hz
 Max. absorbed power = 3,2 W
 Electrical contact capacity = 3(1) A 250 Vac
 Usable probes = NTC 10 K @ 25°C
 Temperature display = 3,0÷99,9 °C
 Resolution = 0,1°C
 Operating room temperature = 0÷50°C
 Insulation class (with installed device) = II
 Protection rating (with installed device) = IP20
 Certifications = CE, ENEC03

Code	Article	Description	Pack.
578190	FIRE WATER HID SIMPLE	Electronic built-in regulator for thermo-fireplaces, 1 circulation pump and "grill" outlet system	5
058007	PROBE	Spare NTC 10K probe	o.r.

FIRE WATER HID

REGULATOR FOR HYDRO FIREPLACES/KITCHENS AND THERMOSTUPS



FIRE WATER HID is a built-in DIN503 electronic regulator for fireplaces, compact, with an attractive design, adaptable to every installation environment. Through its microprocessor logic, it manages the circulator of a water heating system and another circulator in the primary circuit (thermo-fireplace/thermo-heater), a 3-way diverter valve, a flow switch or flow meter, an auxiliary changeover switch. The controller has up to 3 inputs, usable for temperature probes. It also includes 7 different pre-set operating logics depending on the system in question. Complete with immersion probe, electrical box and black aesthetic plate.

Power supply = 230 Vac / 50 Hz
 Max. absorbed power = 3,2 W
 Electrical contact capacity = 3(1) A 250 Vac
 Usable probes = NTC 10 K @ 25°C
 Temperature display = 3,0÷99,9°C
 Resolution = 0,1°C
 Operating room temperature = 0÷50°C
 Insulation class (with installed device) = II
 Protection rating (with installed device) = IP20
 Certifications = CE, ENEC03

Code	Article	Description	Pack.
578257	FIRE WATER HID	Electronic built-in regulator for thermo-fireplaces, 2-circulator system, 3-way diverter valve, flow switch, AUX switch, 3 temperature probe inputs	5
058007	PROBE	Spare NTC 10K probe	5

WATERWARM HYDRAULIC INTERFACE MODULE

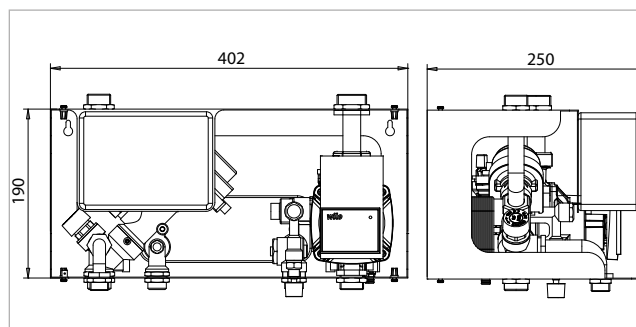
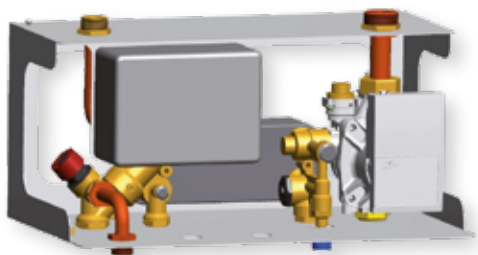

WATERWARM is a compact hydraulic kit, combined with a pellet stove or a thermo-fireplace, which allows the production of domestic hot water and water for heating. It includes a delivery/return group, a brazed exchanger with 20 plates, a diverter valve, a flow switch, an ErP circulator with degasser and built-in drain (only for code 561551) and a pre-wired electrical junction box. Includes white painted cover casing.

Supply voltage = 230 V / 50 Hz
 Max. absorbed power = 50 W
 Operating water temperature = 0/95°C
 Working room temperature = 0/50°C
 Storage temperature = 0/60°C
 Max. heating fluid pressure = 3 bar
 Max. fluid pressure ACS = 6 bar
 Protection rating = IPX4D
 Certifications = CE

Code	Article	Description	Pack.
561550	WATERWARM GRH (without circulator)	DHW production and heating hydraulic module, without circulator	o.r.
561551	WATERWARM GRH (with circulator)	DHW production and heating hydraulic module, with circulator	o.r.

WATERPUFFER WTP5 HYDRAULIC INTERFACE MODULE

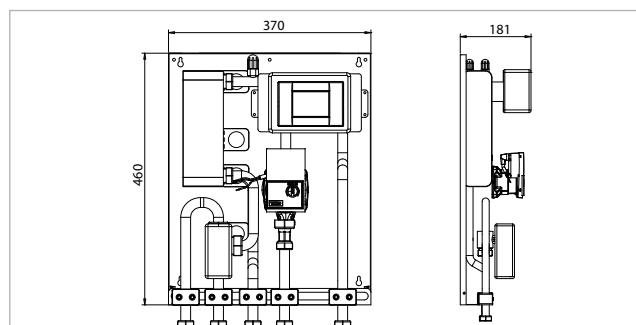

WATERPUFFER WTP5 is a hydraulic separation and integration module between hydraulic circuits with open or closed vessel, powered by different energy sources. The most typical appliance is that of the combination between a thermo-fireplace (or a thermo-heater) and a traditional boiler for the domestic management of heating and hot water with a storage tank. When handling heat produced by biomass, the module disables the gas boiler and send hot water to the domestic heating system or the storage tank, letting the boiler work only as needed.

Supply voltage = 230V / 50Hz
 Max. absorbed power = 100 W
 Water temperature probe = NTC 1%
 Operating water temperature = 95°C
 Max. water probe temperature = 150°C
 Working room temperature = 0/50°C
 Storage temperature = 0/60°C
 Max. fluid pressure = 3 bar
 Protection rating = IPX40
 Certifications = CE

Code	Article	Description	Pack.
561561	WATERPUFFER WTP5 (1 pump)	Hydraulic module for heating and storage, with 1 circulator, 1 x 3-way diverter valve, 1 x 34-plate exchanger, complete with cover casing and FIRE WATER HID control unit.	o.r.
561562	WATERPUFFER WTP5 (2 pumps)	Hydraulic module for heating and storage, with 2 circulators, 1 x 3 way diverter valve, 1 x 34-plate exchanger, complete with cover casing and FIRE WATER HID control unit.	o.r.

WATERLINK WLS4/WTL4 HYDRAULIC INTERFACE MODULE

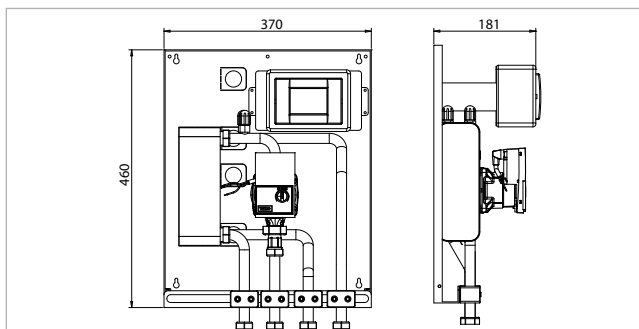
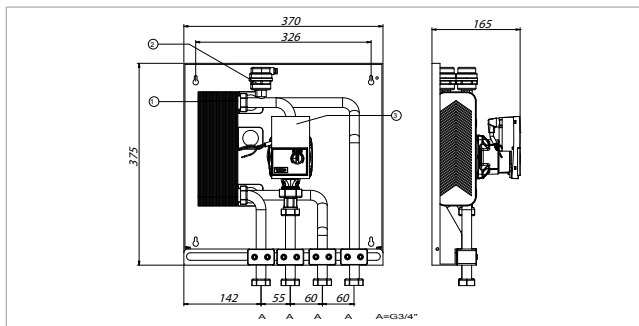

WATERLINK WLS4 / WTL4 is a hydraulic separation module between two heat generators powered by different energy sources. An appliance example is that of combining a thermo-fireplace (or a thermo-heater) and a gas boiler. When handling heat produced by biomass, the module disables the gas boiler and send hot water to the domestic heating system, enabling the boiler only as needed. It is available with a 34-plate and 40-plate exchanger, for 1 or 2 circulators, with or without cover casing and control unit.

Supply voltage = 230 V / 50 Hz
 Max. absorbed power = 100 W
 Water temperature probe = NTC 1 %
 Operating water temperature = 0/95°C
 Max. water probe temperature = 150°C
 Working room temperature = 0/50°C
 Storage temperature = 0/60°C
 Max. fluid pressure = 3 bar
 Protection rating = IPX4D
 Certifications = CE

Code	Article	Description	Pack.
561591	WATERLINK WLS4 (1 pump, 34 plates)	Hydraulic module (heating only), with 1 circulator, 34-plate exchanger, complete with cover casing.	o.r.
561592	WATERLINK WLS4 (2 pumps, 34 plates)	Hydraulic module (heating only), with 2 circulators, 34-plate exchanger, complete with cover casing	o.r.
561593	WALTERLINK WLS4 (1 pump, 40 plates)	Hydraulic module (heating only), with 1 circulator, 40-plate exchanger, complete with cover casing.	o.r.
561594	WATERLINK WLS4 (2 pumps, 40 plates)	Hydraulic module (heating only), with 2 circulators, 40-plate exchanger, complete with cover casing.	o.r.
561595	WATERLINK WLS4 (1 pump, 34 plates)	Hydraulic module (heating only), with 1 circulator, 34-plate heat exchanger, without cover casing.	o.r.
561596	WATERLINK WLS4 (2 pumps, 34 plates)	Hydraulic module (heating only), with 2 circulators, 34-plate heat exchanger, without cover casing.	o.r.
561597	WALTERLINK WLS4 (1 pump, 40 plates)	Hydraulic module (heating only), with 1 circulator, 40-plate exchanger, without cover casing.	o.r.
561598	WATERLINK WLS4 (2 pumps, 40 plates)	Hydraulic module (heating only), with 2 circulators, 40-plate exchanger, without cover casing.	o.r.
561552	WATERLINK WTL4 (1 pump, 34 plates)	Hydraulic module (heating only), with 1 circulator, 34-plate exchanger, complete with cover casing and FIRE WATER HID control unit.	o.r.
561553	WATERLINK WTL4 (2 pumps, 34 plates)	Hydraulic module (heating only), with 2 circulators, 34-plate exchanger, complete with cover casing and FIRE WATER HID control unit.	o.r.
561560	WATERLINK WTL4 (2 pumps, 40 plates)	Hydraulic module (heating only), with 2 circulators, 40-plate exchanger, complete with cover casing and FIRE WATER HID control unit.	o.r.
561599	WLS4 cover	Compact ERP waterlink cover kit	o.r.

WATERLINK WTL6 HYDRAULIC INTERFACE MODULE

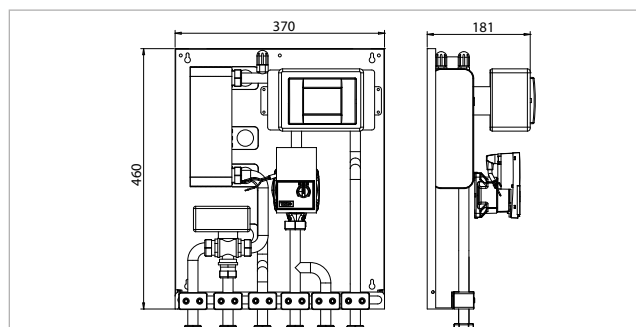

WATERLINK WTL6 is a hydraulic separation module between two heat generators powered by different energy sources. The most typical appliance is that between a thermo-fireplace (or a thermo-heater) and a gas boiler. When handling heat produced by the biomass source, the module disables the traditional boiler and activates the 3-way valve to send hot water to the domestic heating system. Otherwise the 3-way valve is not enabled, allowing the gas boiler to meet the required heating needs.

Supply voltage = 230 V / 50 Hz
 Max. absorbed power = 100 W
 Water temperature probe = NTC 1 %
 Operating water temperature = 0/95°C
 Max. water probe temperature = 150°C
 Working room temperature = 0/50°C
 Storage temperature = 0/60°C
 Max. fluid pressure = 3 bar
 Protection rating = IPX4D
 Certifications = CE

Code	Article	Description	Pack.
561554	WATERLINK WTL6 (1 pump)	Hydraulic module (heating only), with 1 circulator, 1 x 3-way diverter valve, 1 x 34-plate exchanger, complete with cover and FIRE WATER HID control unit.	o.r.
561555	WATERLINK WTL6 (2 pumps)	Hydraulic module (heating only), with 2 circulators, 1 x 3-way diverter valve, 1 x 34-plate exchanger, complete with cover and FIRE WATER HID control unit.	o.r.

WATERCOMBI WTC7 HYDRAULIC INTERFACE MODULE

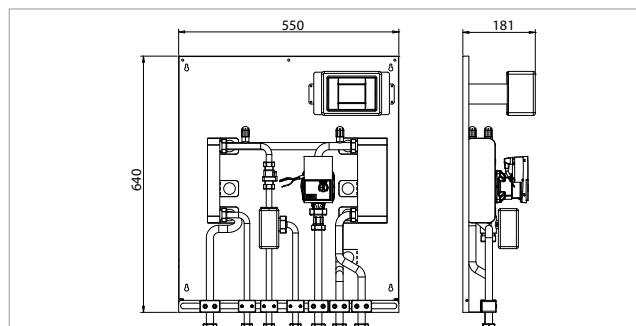

WATERCOMBI WTC7 is a hydraulic separation module between two heat generators powered by different energy sources, with the production of domestic hot water. The most typical appliance is that of the combination between a thermo-fireplace (or a thermo-heater) and a boiler. When handling heat produced by the biomass source, the module disables the traditional boiler and sends hot water to the domestic heating system or directly to the user in the event of requesting domestic hot water. Otherwise, it allows the gas boiler to meet the heating demand and produce domestic hot water.

Supply voltage = 230 V / 50 Hz
 Max. absorbed power = 100 W
 Water temperature probe = NTC 1%
 Operating water temperature = 0/95°C
 Max. water probe temperature = 150°C
 Working room temperature = 0/50°C
 Storage temperature = 0/60°C
 Max. heating fluid pressure = 3 bar
 Max. fluid pressure ACS = 6 bar
 Protection rating = IPX4D
 Certifications = CE

Code	Article	Description	Pack.
561556	WATERCOMBI WTC7 (1 pump)	Hydraulic heating and DHW module, with 1 circulator, 1 x 3-way diverter valve, 1 flow switch, 1 x 30-plate exchanger, 1 x 14-plate exchanger, complete with cover casing and FIRE WATER HID control unit.	o.r.
561557	WATERLINK WTC7 (2 pumps)	Hydraulic heating and DHW module, with 2 circulators, 1 x 3-way diverter valve, 1 flow switch, 1 x 30-plate exchanger, 1 x 14-plate exchanger, complete with cover casing and FIRE WATER HID control unit.	o.r.

KIT GRH

COMPONENTS FOR DOMESTIC HOT WATER PRODUCTION



Hydraulic units and accessories that make up the domestic hot water production kit.

Code	Article	Description	Pack.
561326	GRH DELIVERY UNIT	Hydraulic brass delivery unit, complete with diverter valve and safety valve	o.r.
561327	GRH ACTUATOR	Electric actuator for GRH 230Vac diverter valve	o.r.
561328	GRH RETURN UNIT (quick coupling)	Return brass hydraulic unit, complete with flow switch, loading tap, filter and flow limiter, quick connection for circulator	o.r.
561369	GRH RETURN UNIT (G3 / 4" attack)	Return brass hydraulic unit, complete with flow switch, loading tap, filter and flow limiter, G3/4" fitting	o.r.
561370	GRH FLOW SWITCH	Flow switch, threaded cap and Reed sensor	o.r.

CIRCULATORS ErP

ACCESSORIES AND SPARE PARTS FOR BIOMASS PLANTS



Circulation pumps suitable for domestic installations.

Code	Article	Description	Pack.
076532	CIRCULATOR GRH	Wilo ErP circulator with one-touch complete degasser fitting and expansion vessel fitting	o.r.
076531	HYDRAULIC MODULE CIRCULATOR	Wilo ErP circulator G1" fittings, centre distance 130mm	o.r.

BRAZED HEAT EXCHANGERS

ACCESSORIES AND SPARE PARTS FOR BIOMASS PLANTS



Heat exchangers for hydraulic units with different powers depending on the characteristics of the system.

Code	Article	Description	Pack.
07A708	GRH EXCHANGER	20-plate heat exchanger with switches	o.r.
076198	HYDRAULIC MODULE EXCHANGER	40-plate heat exchanger for 4*G3/4"M	o.r.
078891	HYDRAULIC MODULE EXCHANGER	34-plate heat exchanger 4*G3/4"M	o.r.
07A700	HYDRAULIC MODULE EXCHANGER	30-plate heat exchanger for 4*G3/4"M	o.r.
07A701	HYDRAULIC MODULE EXCHANGER	14-plate heat exchanger 4*G3/4"M	o.r.

DIVERTER VALVES

ACCESSORIES AND SPARE PARTS FOR BIOMASS PLANTS



Diverter valves for hydraulic heating and DHW systems.

Code	Article	Description	Pack.
561351	DIVERTER VALVE	Motorised DN20 diverter valve G3/4"M, vertical body, 230Vac servo motor, 0/90° in 30"	o.r.
561352	DIVERTER VALVE	Motorised DN20 diverter valve 1"M, horizontal body, 230Vac servomotor, 0/90° in 30"	o.r.

CUSTOM ELECTRONICS

CUSTOMISED EQUIPMENT AND SYSTEMS FOR THE OEM SECTOR



Imit specialises in the development and production of customised electronic equipment and systems for the regulation and control of temperature, pressure and humidity in boilers, pellet stoves and chimney flues, heat pumps, fan-coils, electric radiators, home appliances for community applications, electro-medical sterilisers and in general for industrial contexts of various types.

The lengthy operating experience in the field of civil and industrial thermoregulation with the use of both electromechanical and electronic technology allows us to propose innovative, integrated and competitive solutions characterised by high quality standards and in compliance with the international regulations.

DOMOTICS CONTROLS



The TECHNO APP smart home system and the IMIT APP application enable the control and management of temperature and electrical loads via smartphone and/or tablet. The development of this new technology combined with the skills acquired in the many applications for which our products are intended, allows us to provide various solutions dedicated to IoT (Internet of things) evolution ranging from the creation of HW platforms to the development of customised APPs.

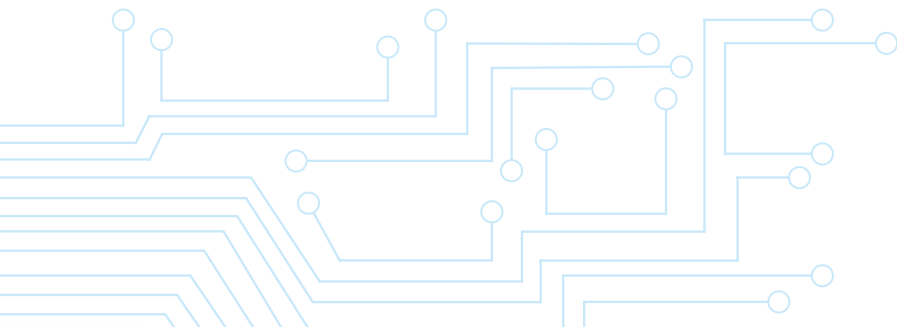

Design

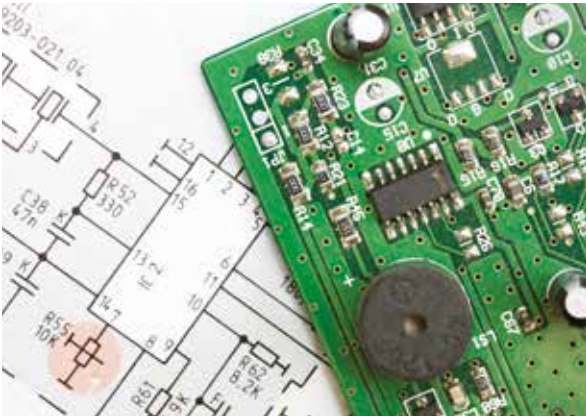

A design team defines, in co-design or autonomously, the technical specifications of the electronic board, finding application in the various sectors of thermoregulation. We develop and produce custom electronic equipment and systems, collaborating with leading manufacturers of heating, air conditioning and appliances.

Production



Production is flexible and guaranteed by the most advanced technologies thanks to the use of THT and SMD assembly machines; all processing is monitored by X-Ray technology and is performed in full compliance with national and international regulations.

Testing



For each product functional tests and memory/micro programming are performed; for each project while needle bed machines are specially designed to perform circuit and mini-functional tests to guarantee the highest quality/reliability of the equipment and systems produced.

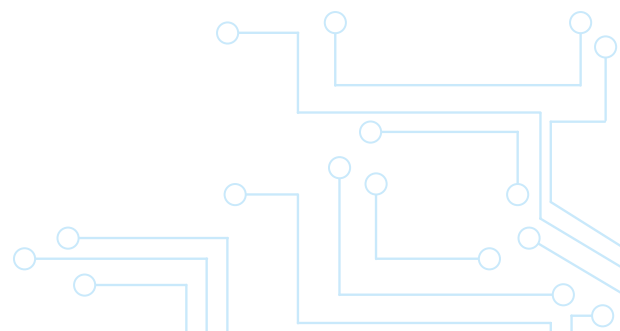

Notes

A series of 25 horizontal dotted lines for writing notes.

Notes

A series of 25 horizontal dotted lines for writing notes.

Product Range
Ed. 2018

25
30



IMITT

www.imit.it

Via Varallo Pombia, 19

28053 Castelletto Ticino (NO) - Italia

tel. +39 0331 941600 - fax +39 0331 973100

e-mail: info@imit.it

