

Fisher™ ED, EAD, and EDR Sliding-Stem Control Valves

Fisher ED, EAD, and EDR single-port control valves shown in figures 1, 2, and 3 have balanced valve plugs, cage guiding, and metal-to-metal seating for all general applications over a wide range of process pressure drops and temperatures. These general purpose, sliding-stem valves are used for either throttling or on-off control of a wide variety of liquids and gases.

The Fisher ED product line is available for a wide range of applications, including sulfide and chloride stress-cracking environments common to the oil and gas production industries. To discuss available constructions, contact your [Emerson sales office](#) and include the applicable codes and standards required for these environments.

The easy-e™ Valve Family

ED, EAD, and EDR valves are part of the versatile easy-e family of Fisher industrial control valves. easy-e valves share the following characteristics:

- Multiple trim material choices
- Trim temperature capability with standard metal seats to 427°C (800°F)
 - FGM gaskets
- Interchangeable, restricted-capacity trims and full-size trims match variable process flow demands
- Different cage/plug styles provide particular flow characteristics for highly-specialized applications. The standard cage comes in three different flow characteristics:
 - quick-opening
 - linear
 - equal percentage
- Noise in gaseous service may be attenuated by using Whisper Trim™ I, Whisper Trim III (figure 8), Whisper NXG Trim, and WhisperFlo™ cages (figure 10)
- 316 stainless steel packing box parts are standard (including packing flange, studs, and nuts)



W1916-4

FISHER ED CONTROL VALVE
WITH 667 ACTUATOR

Features

- **Compliance with the Clean Air Act**—Optional ENVIRO-SEAL™ packing systems (figure 6) provide an improved stem seal to help prevent the loss of process fluid. The ENVIRO-SEAL packing systems feature PTFE, Graphite ULF, or Duplex packing with live-loading for reduced packing maintenance.
- **Valve Plug Stability**— Rugged cage guiding provides high valve plug stability, which reduces vibration and mechanical noise.
- **More Flow Capacity for Initial Investment**— Streamlined flow passages in the the ED, EAD, and EDR valves provide excellent capacities and flow.
- **Balanced Valve Plug Construction**— Balanced valve plug construction permits use of smaller, lower-cost Fisher actuators. Also, trim inventory costs are cut because dimensional standardization permits use of most standard easy-e trim parts.
- **Compliance with European Standards**— Valves are available with dimensions specified by EN/DIN standards. See figure 12.
- **High-Temperature Capability with Class IV or Class V Shutoff**—Use of multiple graphite piston rings (figure 1) permit Class IV shutoff up to 593°C (1100°F). Use of C-seal trim (see figure 5) permits Class V shutoff up to 593°C (1100°F).
- **Sour Service Capability**— Unless otherwise noted, references are to NACE MR0175-2002. Optional materials are available to meet NACE MR0103 and NACE MR0175 / ISO 15156. Material requirements under these standards vary by edition and year of issue; the specific standard must be specified.
- **Operating Economy**—Increased wear resistance provided by standard hardened stainless steel trim means long service life.
- **Maintenance Economy**—The valve body can stay in the pipeline during removal of trim parts. The EDR valve also features easy valve access without removing the actuator.

Table of Contents

Features	2
Specifications	3
ENVIRO-SEAL Packing System Specifications	5
C-seal Trim Description	10
ENVIRO-SEAL and HIGH-SEAL Packing Systems	10
Tables	
C-seal Shutoff Classification	8
Available Constructions	9
Typical Combinations of Metal Trim Parts	11
Whisper Trim III and Whisper NXG Trim Metal Trim Part Materials and Body/Trim Temperature Capabilities	12
WhisperFlo Metal Trim Part Materials and Valve Body/Trim Temperature Capabilities	14

Materials and Temperature Limits for All Other Parts	16
Valve Body/Trim Temperature Capabilities	18
Bonnet Selection Guidelines	20
Maximum Flow Coefficients	20
Metal Trim Parts (NACE)	21
Port Diameters, Valve Plug Travel, and Stem and Yoke Boss Diameters	21
Bolting Materials and Temperature Limits (NACE)	22
Dimensions	24

Specifications

Available Configurations

ED: Single-port, globe-style control valve with cage guiding, balanced valve plug, and push-down-to-close valve plug action (figure 1)

EAD: Angle version of ED control valve, used to facilitate piping or in applications where a self-draining valve is desired (figure 2)

EDR: Same as ED control valve except with push-down-to-open valve plug action (figure 3)

Valve Sizes

See table 2

End Connection Styles⁽¹⁾⁽²⁾

Cast Iron Valves

Flanged: ED, NPS 1 through 8, ■ CL125 flat-face or ■ CL250 raised-face flanges per ASME B16.1

Steel and Stainless Steel Valves

Flanged: ■ CL150, 300, or 600 raised-face (RF) or ring-type joint (RTJ) flanges per ASME B16.5,

■ Raised-face (RF) flanges per EN1092-1/B

Screwed or Socket Welding: NPS 1 through 2, consistent with ASME B16.11

Buttwelding: NPS 1 through 8

Schedules 40 or 80 consistent with ASME B16.25

Socket weld end connection style is not available for EAD

Also, see table 2 and figures 12 and 13

Maximum Inlet Pressures and Temperatures⁽¹⁾⁽²⁾

As listed below, unless limited by maximum pressure drop or material temperature capabilities

Cast Iron Valves

Flanged: Consistent with CL125B or 250B per ASME B16.1

Steel and Stainless Steel Valves

Flanged: Consistent with CL150, 300, and 600⁽³⁾ per ASME B16.34

Screwed or Welding: Consistent with CL600⁽³⁾ per ASME B16.34

Maximum Pressure Drop⁽²⁾

Same as maximum inlet pressure for specific construction defined above, except where further limited as follows:

All Valves Except Those with Whisper Trim III, Whisper NXG Trim, and WhisperFlo Cages: See figure 9

Valves with Whisper Trim III Cages : 0.999 $\Delta P/P_1$ maximum for levels A1 through D3

Valves for NACE MR0175 / ISO 15156 and MR0103: See figure 11

Shutoff Classifications per ANSI/FCI 70-2 and IEC 60534-4

Class II: Standard with single graphite ring and 33 through 203 mm (1.3125 through 8-inch) port size

Class III: Optional for valves with single graphite piston ring and 87 mm (3.4375 inch) or larger port diameter

Class IV: For valves with multiple graphite piston rings and 111 mm (4.375 inch) or larger port diameter

Class V High-Temperature: For valves with port diameters from 73 through 203.2 mm (2.875 through 8-inch) with optional C-seal trim. See table 1

Construction Materials

Valve Body, Bonnet, and Bonnet Spacer or Bottom Flange, if used: ■ Cast iron, ■ WCC carbon steel, ■ CF8M (cast 316 stainless steel), ■ LCC carbon steel, ■ WC9 chrome moly steel, ■ CF3M (cast 316L stainless steel) or ■ other materials upon request

Valve Plug, Cage, and Metal Seating Parts

All Valves Except Those with Whisper Trim III, Whisper NXG Trim, and WhisperFlo Cages: See table 3

Valves with Whisper Trim III, Whisper NXG Trim, and WhisperFlo Cages: See tables 4 and 5

Valves for NACE Specification: See table 10

Bellows Seal Assembly: ■ N06625/S31603 or ■ N06022/N06022

All Other Parts: See table 6

- continued -

Specifications (continued)

Material Temperature Capabilities⁽²⁾

Valve Body/Trim Combinations

All Valves Except Those with Whisper Trim III, Whisper NXG Trim, and WhisperFlo Cages: See table 7
Valves with Whisper Trim III and Whisper NXG Trim Cages: See table 4
Valves with WhisperFlo Cages (NPS 4 and 6 ED): See table 5
All Other Parts: See table 6

Flow Characteristics

Standard Cages: ■ Quick-opening, ■ linear, or ■ equal percentage
Whisper Trim, Whisper NXG Trim, and WhisperFlo Cages: Linear

Flow Directions

ED or EAD: ■ Standard Cage--Normally down, ■ Whisper Trim, Whisper NXG Trim, and WhisperFlo Cages—Always up
EDR: ■ Standard Cage--Normally up, ■ Whisper Trim Cage—Always down

Flow Coefficients and Noise Level Prediction

See table 9 and Catalog 12

Port Diameters and Valve Plug Travels

See table 11

Yoke Boss and Stem Diameters

See table 11

Typical Bonnet Styles

■ Plain or ■ extension. See figures 12 and 13 for standard dimensions. See table 8 for selection guidelines
 ■ ENVIRO-SEAL bellows seal bonnet. See figure 12 for standard dimensions. See figure 7 for view of ENVIRO-SEAL bellows seal bonnet. Also, see Bulletin

59.1:070, ENVIRO-SEAL Bellows Seal Bonnets ([D101641X012](#)), for further information

Packing Arrangements

■ Single PTFE V-ring (standard), ■ double arrangements, ■ leak-off arrangements, ■ ENVIRO-SEAL packing system. See figure 6 for ENVIRO-SEAL configuration
ENVIRO-SEAL Packing Systems in vacuum service: Standard ENVIRO-SEAL packing systems can be used in vacuum service with packing rings in standard orientation. Do not reverse the ENVIRO-SEAL PTFE packing rings. See Bulletin 59.1:061, ENVIRO-SEAL Packing Systems for Sliding-Stem Valves ([D101633X012](#)), for further information

Approximate Weights

NPS 1: 14 kg (30 lb)
 NPS 1-1/2: 20 kg (45 lb)
 NPS 2: 39 kg (85 lb)
 NPS 2-1/2: 45 kg (100 lb)
 NPS 3: 57 kg (125 lb)
 NPS 4: 77 kg (170 lb)
 NPS 6: 159 kg (350 lb)
 NPS 8: 408 kg (900 lb)

Optional Safety Instrumented System Classification

SIL3 capable — certified by exida Consulting LLC

Additional Options

■ Seal welding of EDR valve body/bonnet joint for temperatures above 232°C (450°F), ■ lubricator, ■ lubricator/isolating valve, ■ drilled and tapped connection in extension bonnet for leak-off service, ■ valve body drain plug, ■ style 3 fabricated extension bonnet made on order to a specific length for cryogenic service, ■ style NS bonnet for seismic service requirements, ■ packings suitable for nuclear service, ■ C-seal trim for Class V high-temperature shutoff

1. EN (or other) ratings and end connections can usually be supplied; consult your [Emerson sales office](#).
 2. The pressure/temperature limits in this bulletin and in any applicable standard limitations should not be exceeded.
 3. Certain bonnet bolting material selections may require a CL600 easy-e valve assembly to be derated. Contact your Emerson sales office for more information.
 4. Limitation based on excessive noise increases if max ΔP/P1 ratio for a given cage level is exceeded.

ENVIRO-SEAL Packing System Specifications

Applicable Stem Diameters

- 9.5 mm (3/8 inches), ■ 12.7 (1/2), ■ 19.1 (3/4), ■ 25.4 (1), and ■ 31.8 (1-1/4) diameter valve stems

Maximum Pressure/Temperature Limits⁽¹⁾

To Meet the EPA Fugitive Emission Standard of 100 PPM⁽²⁾

For ENVIRO-SEAL PTFE and ENVIRO-SEAL Duplex packing systems: full CL300 up to 232°C (450°F)

For ENVIRO-SEAL Graphite ULF packing system: 104 bar (1500 psig) at 316°C (600°F)

Construction Materials

PTFE Packing Systems

Packing Ring and Lower Wiper: PTFE V-ring⁽³⁾

Male and Female Adaptor Rings: Carbon-filled PTFE

V-ring

Anti-Extrusion Washer: Filled PTFE

Lantern Ring: S31600 (316 stainless steel)

Spring: ■ 17-7PH stainless steel or ■ N06600

Packing Box Flange: S31600

Packing Follower: S31600 lined with carbon-filled PTFE

Packing Box Studs: Strain-hardened 316 stainless steel

Packing Box Nuts: 316 stainless steel SA194 Grade 8M

Graphite ULF Packing Systems

Packing Ring: Graphite rings

Spring: ■ 17-7PH stainless steel or ■ N06600

Packing Box Flange: S31600

Packing Follower: S31600 lined with carbon-filled PTFE

Packing Box Studs: Strain-hardened 316 stainless steel

Packing Box Nuts: 316 stainless steel SA194 Grade 8M

1. Refer to the valve specifications in this bulletin for pressure/temperature limits of valve parts. Do not exceed the pressure/temperature rating of the valve. Do not exceed any applicable code or standard limitation.
2. The Environmental Protection Agency (EPA) has set a limit of 100 parts per million (ppm) for fugitive emissions from a valve in selected VOC (Volatile Organic Compound) services.
3. In vacuum service, reversing the ENVIRO-SEAL PTFE packing rings is not necessary.

Figure 1. Fisher ED Sectional

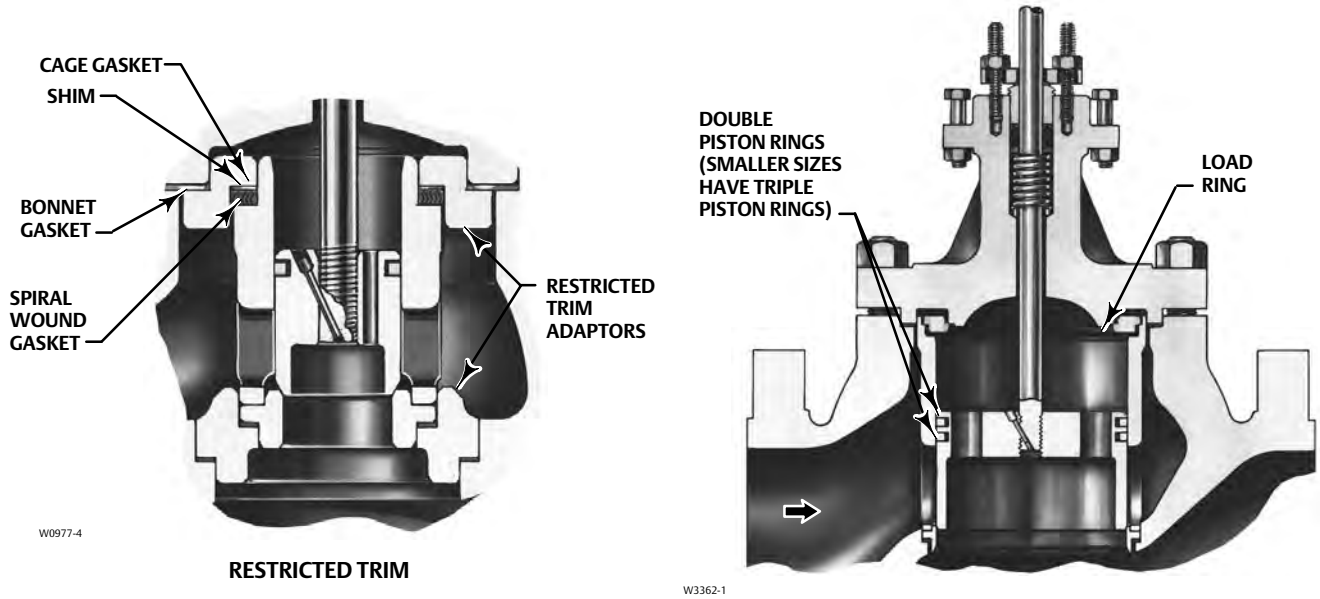

NPS 8 VALVE WITH OPTIONAL MULTIPLE PISTON RINGS FOR CLASS IV SHUTOFF (ALSO AVAILABLE IN OTHER SIZES)

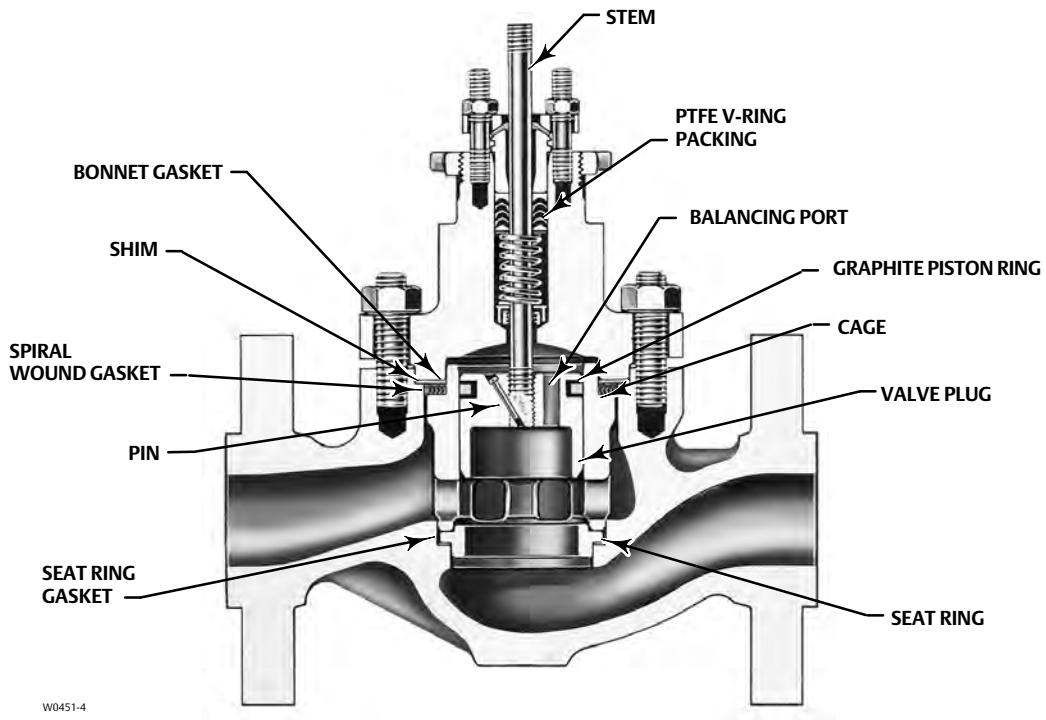

STANDARD NPS 1 THROUGH 6 CONSTRUCTION

Figure 2. Fisher EAD Sectional

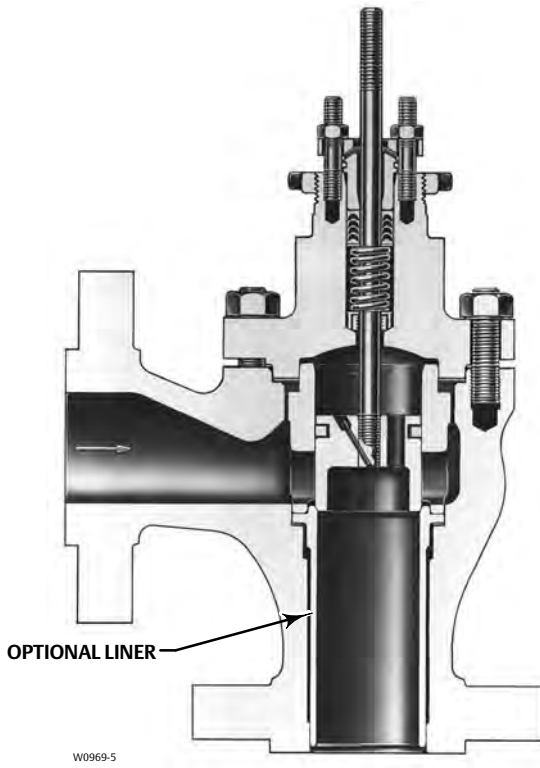

Figure 3. Fisher EDR Sectional

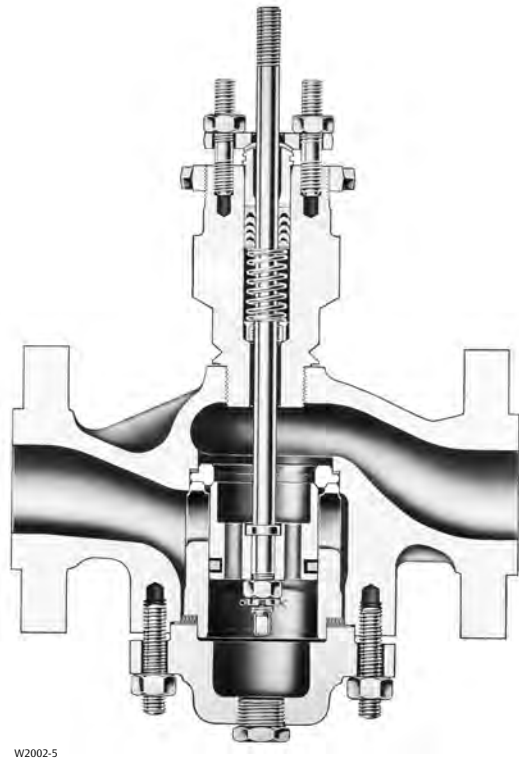

Figure 4. Typical Valve with WhisperFlo Aerodynamic or Whisper NXG Trim

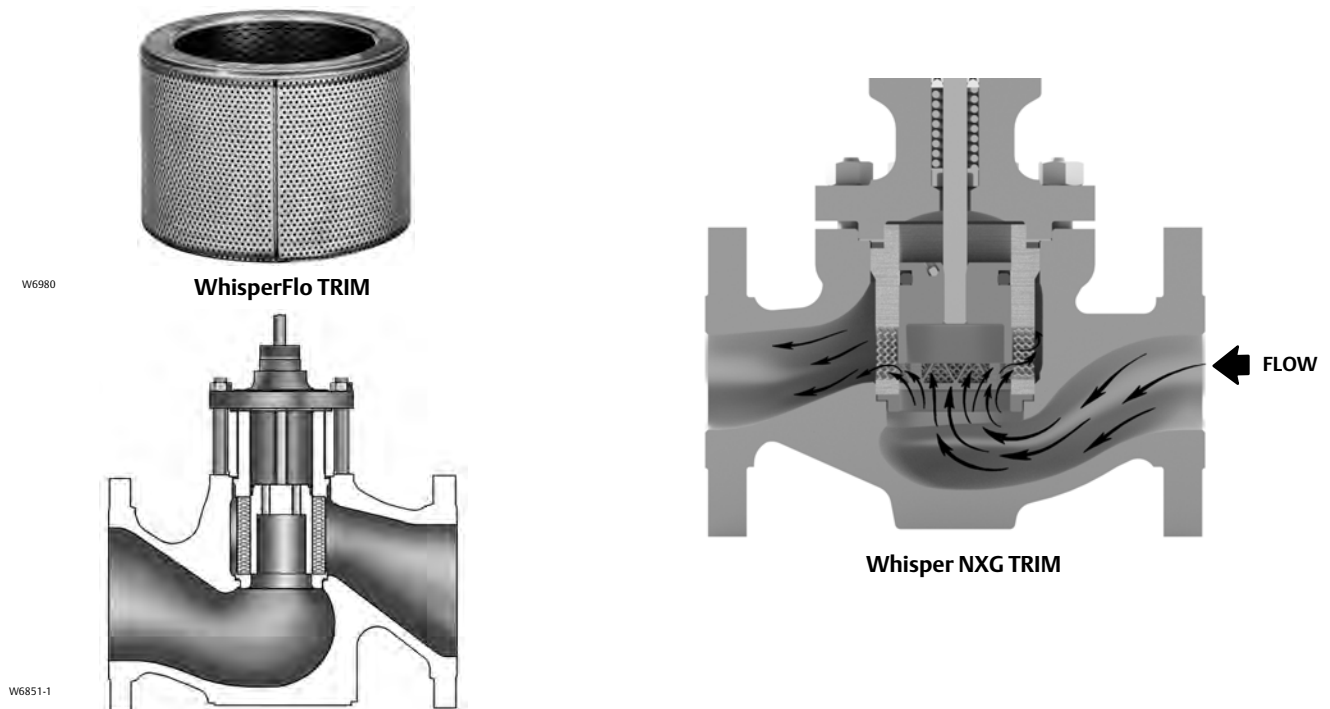
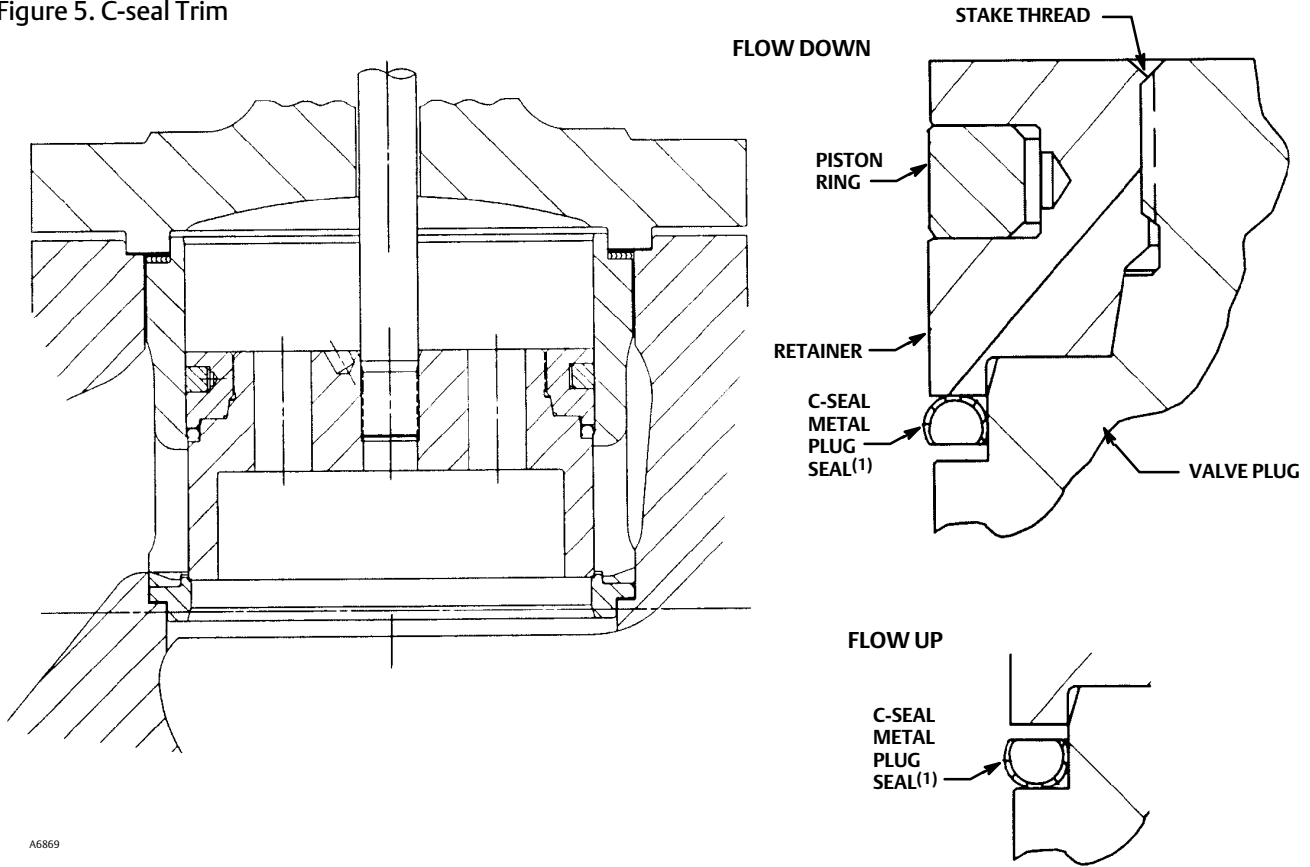

Table 1. C-seal Shutoff Classification

VALVE (PRESSURE RATING)	VALVE SIZE	PORT DIAMETER		CAGE STYLE	ANSI/FCI LEAKAGE CLASS
	NPS	mm	Inches		
ED (CL150-600)	2 1/2	73	2.875	Eq.%, Linear, Whisper I, Cav III 1 stage, Whisper III, Whisper NXG	V to 593°C (1100°F) [for port diameters from 73 through 203.2 mm (2.875 though 8-inch) with optional C-seal trim]
	3	87.3	3.4375	Cav III 2 stage	
		73	2.875		
	4	73	2.875	Eq.%, Linear, Whisper I, Cav III 1 stage, Cav III 2 stage	
		87.3	3.4375	Whisper III, Whisper NXG	
		11.1	4.375	Eq.%, Linear, Whisper I, Cav III 1 stage, Whisper III, Whisper NXG	
	6	136.5	5.375	Whisper III, Whisper NXG, Cav III 2 stage	
		177.8	7	Eq.%, Linear, Whisper I, Cav III 1 stage, Whisper III, Whisper NXG	
	8	177.8	7	Cav III 2 stage	
		203.2	8	Eq.%, Linear, Whisper I, Cav III 1 stage, Whisper III, Whisper NXG	

Figure 5. C-seal Trim



A6869

Note:

1. Reverse the orientation of the C-seal plug seal for proper shutoff when valve is used in a process with different fluid flow direction.

Table 2. Available Constructions

VALVE	VALVE SIZE, NPS	VALVE BODY MATERIAL AND END CONNECTION STYLE ⁽¹⁾							
		Carbon Steel, Alloy Steel, or Stainless Steel Valve Body						Cast Iron Valve Body	
		Screwed	RF or RTJ Flanged			Butt-welding	Socket Weld	CL125 FF Flanged	CL250 RF Flanged
CL150	CL300		CL600						
ED	1, 1-1/2, or 2 2-1/2, 3, 4, 6, or 8	X	X	X	X	X	X	X	X
		---	X	X	X	X	---	X	X
EAD	1 or 2 3, 4, or 6	---	X	X	X	X	---	---	---
		---	X	X	X	X	---	---	---
EDR	1, 1-1/2, or 2 2-1/2, 3, or 4	X	X	X	X	X	X	X	X
		---	X	X	X	X	---	X	X
VALVE	VALVE SIZE, DN	STEEL VALVE BODY MATERIAL AND RAISED-FACE END CONNECTION STYLE ⁽²⁾					PN40	PN63	PN100
		PN16	PN25	PN40	PN63	PN100			
ED	25, 40, 50, 65, 80, 100, 150, or 200	X	X	X	X	X	X	X	
EAD	25, 50, 80, 100, or 150	X	X	X	X	X	X	X	
EDR	25, 40, 50, 65, 80, or 100	X	X	X	X	X	X	X	

X = Available Construction.
 1. End connection style abbreviations: FF - Flat Faced, RF - Raised Face, RTJ - Ring Type Joint.
 2. End connection EN1092-1/B.

C-seal Trim Description

C-seal trim is available for valves with port diameters from 2.875 inches through 8 inches.

With C-seal trim, a balanced valve can achieve high-temperature, Class V shutoff. Because the C-seal plug seal is formed from metal (N07718 nickel alloy) rather than an elastomer, a valve equipped with the C-seal trim can be applied in processes with a fluid temperature of up to 593°C (1100°F).

ENVIRO-SEAL and HIGH-SEAL Packing Systems

ENVIRO-SEAL and HIGH-SEAL packing systems offer exceptional sealing capabilities. They easily install in your existing valves or can be purchased with new valves. These systems may help prevent the loss of process fluid. The long operational life and reliability of

these systems also reduces your maintenance costs and downtime.

For applications requiring compliance with environmental protection regulations, the unique Fisher ENVIRO-SEAL packing system (figure 6) and a unique ENVIRO-SEAL bellows seal system (figure 7) are offered. The emission control packing system keeps emission concentrations below the EPA 100 ppm requirement.

For an excellent stem seal in applications that are not environmentally-sensitive, the Fisher HIGH-SEAL Graphite ULF packing system (figure 6) is offered. The HIGH-SEAL packing system provides excellent sealing at pressure/temperature ratings beyond ENVIRO-SEAL limits. ENVIRO-SEAL systems may also be applied for excellent stem sealing in higher pressure/temperature applications not requiring EPA compliance.

ENVIRO-SEAL packing systems, available with PTFE, Graphite ULF, or Duplex packing, and the HIGH-SEAL packing systems, Graphite ULF and graphite composite, feature live-loading and unique packing-ring arrangements for long-term, consistent sealing performance.

Table 3. Typical Combinations of Metal Trim Parts⁽¹⁾ for all Valves Except Those for NACE Specification, Whisper Trim III, Whisper NXG Trim, and WhisperFlo Cages

Trim Designation	Valve Plug	Cage	Seat Ring	Liner (EAD Valve Only)
1 (standard for ED, EAD, and EDR in all valve body materials except CF8M)	S41600 HT	17-4 SST HT ⁽⁸⁾	S41600 HT or CA15 HT ⁽²⁾	S41600 HT
	17-4 SST HT ⁽⁸⁾			
3 ⁽⁷⁾ and 3H ⁽³⁾	S31600 with seat and guide hard faced with CoCr-A hardfacing alloy	R30006 or R30016 (alloy 6)	R30006 (alloy 6)	---
4 ⁽⁴⁾	S31600	17-4 SST HT	S31600	S31600
5 ⁽⁶⁾ and 5H ⁽³⁾⁽⁶⁾	S31600 with seat and guide hard faced with CoCr-A hardfacing alloy	R31233	R30006 (alloy 6)	---
6 ⁽⁶⁾	S31600 with seat and guide hard faced with CoCr-A hardfacing alloy	S31603 CRPL	R30006 (alloy 6)	---
27	S31600 with seat and guide hard faced with CoCr-A hardfacing alloy	316 SST with electroless nickel coating (ENC)	R30006 (alloy 6)	---
28 ⁽⁵⁾	S31600 with seat hard faced with CoCr-A hardfacing alloy			
29 (standard for CF8M bodies in all designs) ⁽⁵⁾	S31600	316 SST with electroless nickel coating (ENC)	S31600	S31600
37 and 37H ⁽³⁾	S31600 with seat and guide hard faced with CoCr-A hardfacing alloy	17-4 SST HT	R30006 (alloy 6)	---
316L	S31603	316 SST with electroless nickel coating (ENC)	S31603	---
316L HF	S31603 with seat and guide hard faced with CoCr-A hardfacing alloy	316L SST with electroless nickel coating (ENC)	R30006 (alloy 6)	---

1. Nonferrous-alloy combinations are also available. Consult your [Emerson sales office](#) for details.
2. CA15 is used for NPS 6 and 8 full-size and restricted-trim valves.
3. Trims 3H, 5H, and 37H have clearances for high-temperature service.
4. Not for use with Whisper Trim I.
5. Not use with Whisper Trim I with 136 mm (5.375 inch) and larger ports.
6. Only available for NPS 8 Whisper Trim I.
7. For trim 3, upper temperature limited to 316°C (600°F) when used for Whisper Trim I.
8. For NPS 8 Whisper Trim I.

Table 4. Whisper Trim III and Whisper NXG Trim Metal Trim Part Materials and Body/Trim Temperature Capabilities

TRIM DESIGNATION	VALVE PLUG	CAGE	CAGE RETAINER	BAFFLE (FOR LEVEL D3 CAGE ONLY)	SEAT RING FOR METAL-SEAT CONSTRUCTION	DISK SEAT AND RETAINER FOR PTFE-SEAT CONSTRUCTION	STEM	BODY, BONNET & BONNET SPACER	MATERIAL TEMPERATURE CAPABILITY			
									°C		°F	
									Min	Max	Min	Max
19.1 through 111.1, 177.8 and 203.2 mm (0.75 through 4.375, 7 and 8 Inch) Port Sizes with Whisper III Trim Cage												
301G	S41600	17-4 SST	---	Steel	S41600	---	S31600	WCC, WC9	-29	427	-20	800
								CF8M ⁽⁸⁾	-29	176	-20	350
312G ⁽¹⁾	S31600/CoCr-A Seat & Guide	316 SST/ENC Electroless Nickel Coated	---	S31600	R30006	---	S20910	WCC, WC9	-29	343	-20	650
								CF8M	29	343	-20	650
315G ⁽¹⁾	S31600/CoCr-A Seat & Guide	316 SST Chrome Plate	---	S31600	R30006	---	S20910	WCC, WC9	-29	316	-20	600
								CF8M	-198	316	-325	600
318G	F22/CoCr-A Seat & Guide	2.25 Cr-1 Mo Nitrided	---	WC9	R30006	---	S41000/S42200 ⁽⁴⁾	WCC	-29	427	-20	800
								WC9	-29	593	-20	1100
306	S31803/CoCr-A Seat & Guide (< 3"Port), S31803/Ultimet Seat & Guide (≥ 3"Port)	2205 Duplex ⁽⁵⁾ Chrome Plate	---	S31803	S31803/CoCr-A (< 3"Port), S31803/Ultimet (≥ 3"Port)	---	S31803	WCC, WC9, CF8M	-29	316	-20	600
307G	S31600/CoCr-A Seat & Guide	17-4 SST	---	Steel	R30006	---	S31600	WCC, WC9	-29	210	-20	410
307GH ⁽³⁾	S31600/CoCr-A Seat & Guide	17-4 SST	---	Steel	R30006	---	S31600	WCC, WC9	210	427	410	800
19.1 through 111.1, 177.8 and 203.2 mm (0.75 through 4.375, 7 and 8 Inch) Port Sizes with Whisper NXG Trim Cage												
301GNXG	S41600	17-4 H1075	---	---	S41600	---	S31600	WCC, WC9	-29	427	-20	800
								CF8M ⁽⁸⁾	-29	176	-20	350
312G ⁽¹⁾ NXG	S316/CoCr-A Seat & Guide	S31603/ENC	---	---	R30006	---	S20910	WCC, WC9	-29	343	-20	650
								CF8M	29	343	-20	650
312GCNXG	S31600/CoCr-A Seat & Guide	17-4 H1075	---	---	R30006	---	S31600	WCC, WC9	-29	210	-20	410
307GH ⁽³⁾ NXG	S31600/CoCr-A Seat & Guide	17-4 H1075	---	--	R30006	---	S31600	WCC, WC9	210	427	410	800
306NXG	S31803/Ultimet seat and guide	R31233 (Ultimet)	---	---	S31803/Ultimet	---	S31803	WCC, WC9, CF8M	-29	316	-20	600

-continued-

Table 4. Whisper Trim III and Whisper NXG Trim Metal Trim Part Materials and Body/Trim Temperature Capabilities (continued)

TRIM DESIGNATION	VALVE PLUG	CAGE	CAGE RETAINER	BAFFLE (FOR LEVEL D3 CAGE ONLY)	SEAT RING FOR METAL-SEAT CONSTRUCTION	DISK SEAT AND RETAINER FOR PTFE-SEAT CONSTRUCTION	STEM	BODY, BONNET & BONNET SPACER	MATERIAL TEMPERATURE CAPABILITY			
									°C		°F	
									Min	Max	Min	Max
136.5 mm (5.375 Inch) Port												
301	S17400	416 SST	WCC/ENC	Steel	S41600	--	S31600	WCC, WC9	-29	343	-20	650
								CF8M	-29	163	-20	325
301 A	S17400	416 SST	WCC/Nitrided	Steel	S41600	--	S31600	WCC, WC9	232	427	450	800
304	S31600/CoCr-A Seat & Guide	416 SST	WCC/ENC	Steel	S31600/CoCr-A Seat	--	S31600	WCC, WC9	-29	343	-20	650
								CF8M	-29	177	-20	350
312 ⁽¹⁾	S31600/CoCr-A Seat & Guide	316 SST/ENC Electroless Nickel Coated	316/ENC Electroless Nickel Coated	S31600	R30006	--	S20910	WCC, WC9, CF8M	-29	343	-20	650
315	S31600/CoCr-A Seat & Guide	316 SST/Electrolyzed Chrome Coat	S31600/Electrolyzed Chrome Coat	S31600	S31600/CoCr-A	--	S31600/S20910 ⁽⁷⁾	WCC, WC9	-29	260	-20	500
								CF8M	-198	537 ⁽²⁾	-325	1000 ⁽²⁾
318	S31600/CoCr-A Seat & Guide	2.25 Cr-1 Mo Nitrided	WC9 Nitrided ⁽⁶⁾	WC9	S31600/CoCr-A Seat	--	S20910	WCC	-29	427	-20	800
								WC9	-29	593	-20	1100
306	S31803/Ultimet Seat & Guide	2205 Duplex ⁽⁵⁾ Chrome Plate	--	S31803	S31803/Ultimet	--	S31803	WCC, WC9, CF8M	-29	316	-20	600

1. NACE compatible trims meets NACE MR0175 2002, MR0175/ISO15156, MR0103.
2. May be used up to 593°C (1100°F) if manufacturing process controls carbon content to 0.04% minimum or 0.08% maximum.
3. For high temperature service.
4. Trim 318G uses S41000 stem up to 538°C (1000°F) and S42200 stem above 538°C (1000°F).
5. 22 Cr-5Ni duplex stainless steel.
6. With C-seal construction use F22 alloy steel/CoCr-A/Nitrided cage material.
7. Trim 315 uses S31600 stem up to 427°C (800°F) and S20910 stem above 427°C (800°F).
8. Trim 301G and 301GNXG can be used up to 216°C (420°F) with NPS 3 CF8M body, can be used up to 288°C (550°F) with NPS 2 CF8M body.

Table 5. WhisperFlo Metal Trim Part Materials and Valve Body/Trim Temperature Capabilities (NPS 4 and 6 Fisher ED)

TRIM DESIGNATION	VALVE BODY	VALVE PLUG	CAGE	CAGE RETAINER	SEAT	MATERIAL TEMPERATURE CAPABILITY			
						°C		°F	
						Min	Max	Min	Max
901	WCC	S41600	410 SST	WCC ENC	S41600	-29	343	-20	650
902	WCC	S31600/CoCrA Seat and Guide	410 SST	WCC ENC	S31600/CoCrA	-29	343	-20	650
915	WCC	S31600/CoCrA Seat and Guide	410 SST	WCC/Nitride	S31600/CoCrA	343	427	650	800
916	WC9	S31600/CoCrA Seat and Guide	410 SST	WC9/Nitride	S31600/CoCrA	343	538	650	1000
926	WCC	S31600/CoCrA Seat and Guide	410 SST NACE	WCC/NACE/ENC	S31600/CoCrA	-29	343	-20	650
936	316 CF8M	S31600/CoCrA Seat and Guide	316 SST/R31233	S31600/ENC	S31600/CoCrA	-198	343	-325	650
946	316 CF8M	S31600/CoCrA Seat and Guide	316 SST/R31233	S31600/Nitride	S31600/CoCrA	343	538	650	1000
990	CD3MN	S31803/CoCrA Seat and Guide	2205 Duplex ⁽¹⁾ /R31233	S31803/ Cr Plate	S31803/CoCrA Seat	-51	316	-60	600
	LCC					-46	316	-51	600
	WCC					-29	316	-20	600

1. 22 Cr-5Ni duplex stainless steel

Figure 6. ENVIRO-SEAL and HIGH-SEAL Packing Systems

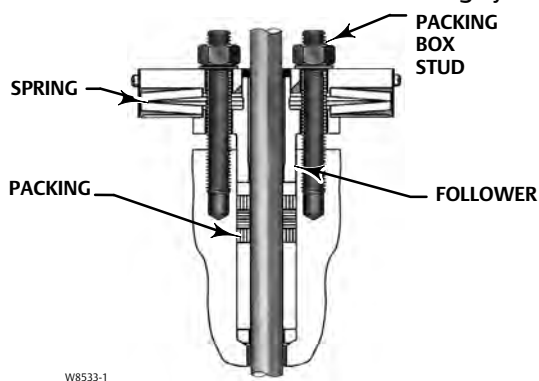

TYPICAL HIGH-SEAL PACKING SYSTEM WITH GRAPHITE ULF PACKING

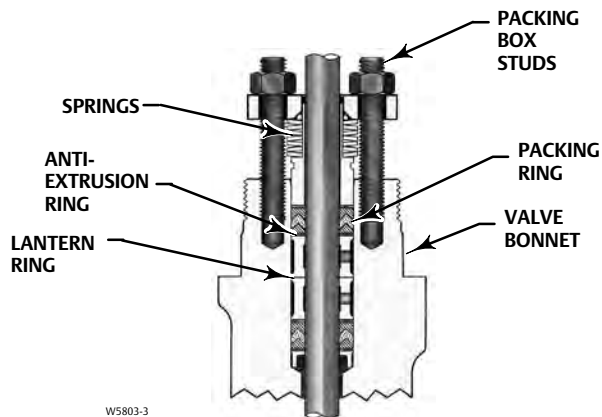

TYPICAL ENVIRO-SEAL PACKING SYSTEM WITH PTFE PACKING

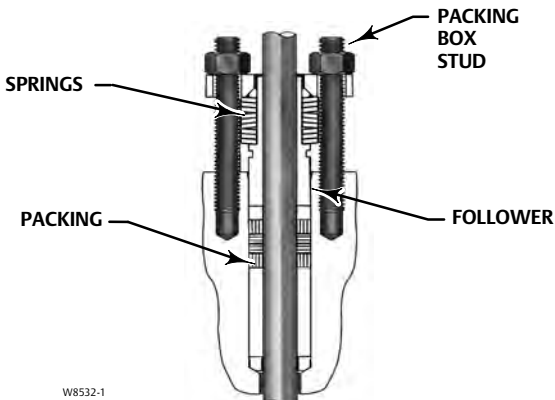

TYPICAL ENVIRO-SEAL PACKING SYSTEM WITH GRAPHITE ULF PACKING

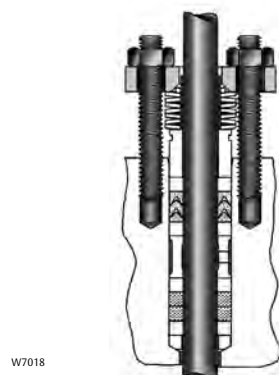

TYPICAL ENVIRO-SEAL PACKING SYSTEM WITH DUPLEX PACKING

Figure 7. Cutaway of ENVIRO-SEAL Bellows Seal Bonnet and Internal Shroud, Showing Bellows



Figure 8. Whisper Trim III Cage in Fisher ED Valve

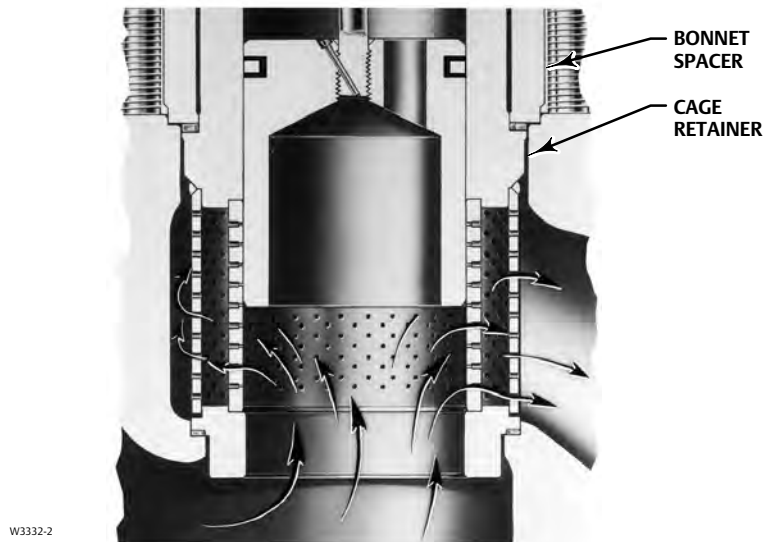
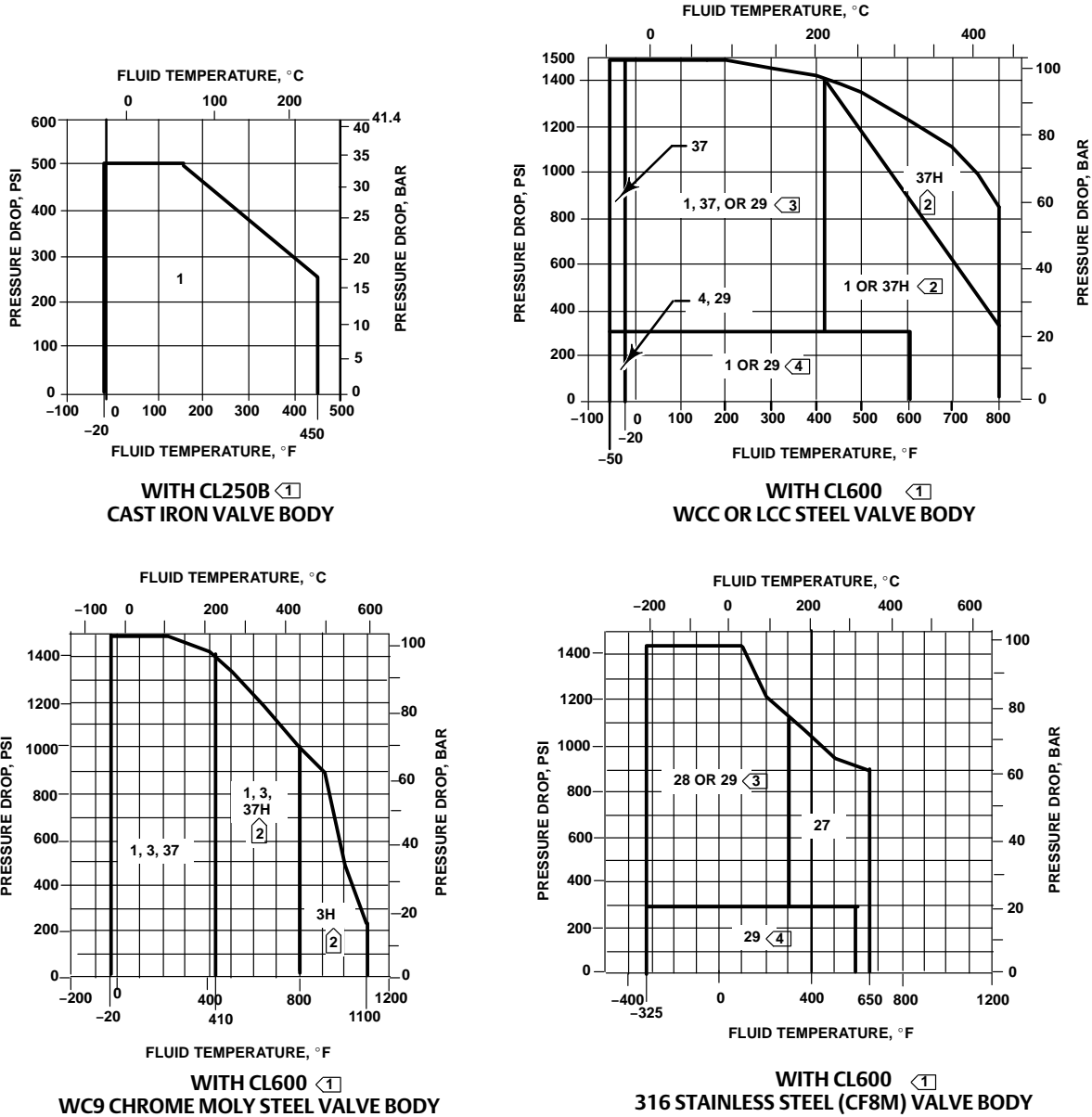

Table 6. Materials and Temperature Limits for All Other Parts

PART			MATERIAL	MATERIAL TEMPERATURE CAPABILITY			
				°C		°F	
				Min	Max	Min	Max
Body-to-bonnet bolting. See table 13 for NACE bolting materials and temperature limits	Cast iron valve body	Cap screws	Steel SAE Grade 5	-29	232	-20	450
		WCC, or WC9 valve body	Studs	Steel SA-193-B7	-29	427 ⁽¹⁾	-20
	Nuts		Steel SA-194-2H				
	LCC valve body	Studs	Steel SA-193-B7	-46	343 ⁽¹⁾	-50	650 ⁽¹⁾
		Nuts	Steel SA-194-2H				
	WC9 valve body	Studs	Steel SA-193-B16	-29	566 ⁽¹⁾	-20	1050 ⁽¹⁾
		Nuts	Steel SA-194-7				
	CF3M or CF8M (316 SST) valve body	Studs	Steel SA-193-B7 (NACE [non-exposed bolting])	-48	427 ⁽¹⁾	-55	800 ⁽¹⁾
		Nuts	Steel SA-194-2H (NACE [non-exposed bolting])				
		Studs	304 stainless steel SA-320-B8	-198	38	-325	100
		Nuts	304 stainless steel SA-194-8				
Studs		316 stainless steel SA-193-B8M (strain hardened)	-198 ⁽²⁾	427 ⁽¹⁾	-325 ⁽²⁾	800 ⁽¹⁾	
	Nuts	316 stainless steel SA-194-8M					
Piston ring	Graphite (FMS 17F27)	Oxidizing service	-46 ⁽³⁾	427	-50 ⁽³⁾	800	
		Non-oxidizing service	-46 ⁽³⁾	482	-50 ⁽³⁾	900	
	Graphite (FMS17F39)	Oxidizing service	-46 ⁽³⁾	560	-50 ⁽³⁾	1000	
		Non-oxidizing service	-46 ⁽³⁾	593	-50 ⁽³⁾	1100	
Valve plug stem		S31600 (S20910, NACE Std.) or S31603					
Pin (ED or EAD valve only)		S31600 or S31603	-198 ⁽²⁾	593	-325 ⁽²⁾	1100	
Castle nut and cotter pin (EDR valve only)		18-8 stainless steel					
Load ring (NPS 8 ED valve only)		S17400	-101	316	-150	600	
		N06600	-254	593	-425	1100	
		N05500	-204	260	-400	500	
Restricted trim adaptors		Cast iron	-73	232	-100	450	
		WCC steel	-29	427	-20	800	
		S31600	-198 ⁽²⁾	593	-325 ⁽²⁾	1100	
Seat ring, bonnet and cage gaskets		FGM (standard)	-198	593 ⁽⁴⁾	-325	1100 ⁽⁴⁾	
		PTFE-coated N04400	-73	149	-100	300	
Spiral wound gaskets		N06600/graphite (FGM-standard)	-198	593 ⁽⁴⁾	-325	1100 ⁽⁴⁾	
		N04400/composition	-73	232	-100	450	
Shim		S31600	These materials not limiting factors				
		N04400					
Packing (temperatures shown are material temperature capabilities). See table 8 for proper bonnet selection.		PTFE V-ring	-40	232	-40	450	
		PTFE/composition	-73	232	-100	450	
		Graphite ribbon/filament	-198	538 ⁽⁶⁾	-325	1000 ⁽⁶⁾	
		Graphite ribbon for high-temperature oxidizing service	371	649	700	1200	
Packing flange, studs and nuts when used with standard bonnet		S31600	-198 ⁽²⁾	593 ⁽¹⁾	-325 ⁽²⁾	1100 ⁽¹⁾	
Packing follower, and packing spring ⁽⁵⁾ or lantern ring		S31600	-198 ⁽²⁾	593	-325 ⁽²⁾	1100	
Packing box ring		S31600					
Extension bonnet bushing	Trims 1 & 37H	S41600	-29	427	-20	800	
	Other trims	S31600	-198 ⁽²⁾	593	-325 ⁽²⁾	1100	

1. Lubricated nuts are standard.
 2. May be used down to -254°C (-425°F) if manufacturing process includes Charpy impact test.
 3. This minimum is due to thermal expansion differential between piston ring and cage at low temperatures.
 4. Except 427°C (800°F) on oxidizing service.
 5. Spring is used only with single PTFE V-ring packing; lantern ring replaces spring in other packings.
 6. Except 371°C (700°F) on oxidizing service.

Figure 9. Typical Trim Used for All Valves Except with Whisper Trim III Cage, Whisper NXG Trim, and WhisperFlo Cage



B1470-7

Notes:

- (1) Do not exceed the maximum pressure and temperature for the pressure rating of the valve material used, even though the trims shown may have higher capabilities.
- (2) Be especially careful to specify service temperature if trim 3 or 37 is selected, as different thermal expansion rates require special plug clearances. Specify trim 37H for temperatures above 210 °C (410 °F). Specify trim 3H for temperatures above 427 °C (800 °F).
- (3) Trim 29 may be used up to 103 bar (1500 psi) with clean, dry gas.
- (4) Use trim 27 instead of trim 29 for nonlubricating fluids such as superheated steam or dry gases between 149 and 316 °C (300 and 600 °F).

Table 7. Valve Body/Trim Temperature Capabilities⁽¹⁾ For All Valves Except with Whisper Trim III Cage, Whisper NXG Trim, and NPS 4 and 6 ED with WhisperFlo Cage

VALVE BODY/BONNET ⁽²⁾ MATERIAL	TRIM DESIGNATION	VALVE SIZE, NPS	MATERIAL TEMPERATURE CAPABILITY			
			°C		°F	
			Min	Max	Min	Max
Cast Iron	1,3,27, or 29	All	-29	232	-20	450
	5 ⁽⁵⁾	8	-29	232	-20	450
	6 ⁽⁵⁾		-29	232	-20	450
	37	All	-29	210	-20	410
	37H		210	232	410	450
WCC steel	1	All	-29	427	-20	800
	4		-29	210	-20	410
	5 ⁽⁵⁾	8	-29	316	-20	600
	5H ⁽⁵⁾		316	427	600	800
	6 ⁽⁵⁾	All (except limited to 338 °C [640 °F] for NPS 4 and 6)	-29	316	-20	600
	27		-29	343	-20	650
	29		-29	149 ⁽⁴⁾	-20	300 ⁽⁴⁾
	37		-29	210	-20	410
37H	All	210	427	410	800	
WC9 Chrome moly steel	1 or 3	All	-29	427 ⁽⁶⁾	-20	800 ⁽⁶⁾
	5 ⁽⁵⁾	8	-29	316	-20	600
	6 ⁽⁵⁾		-29	316	-20	600
	27	All (except limited to 338 °C [640 °F] for NPS 4 and 6)	-29	343	-20	650
	29		-29	149 ⁽⁴⁾	-20	300 ⁽⁴⁾
	37		-29	210	-20	410
	3H		427	593	800	1100
	5H ⁽⁵⁾	8	316	593	600	1100
37H	All	210	427	410	800	
LCC steel	1	All	-29	343	-20	650
	4		-46	210	-50	410
	5 ⁽⁵⁾	8	-46	316	-50	600
	6 ⁽⁵⁾		-46	316	-50	600
	27	All (except limited to 338 °C [640 °F] for NPS 4 and 6)	-46	343	-50	650
	29		-46	149 ⁽⁴⁾	-50	300 ⁽⁴⁾
	37		-46	210	-50	410
	37H		210	343	410	650
CF3M (316L stainless steel)	316L	All	-198 ⁽³⁾	149 ⁽⁴⁾	-325 ⁽³⁾	300 ⁽⁴⁾
	316HF		-198 ⁽³⁾	343	-325 ⁽³⁾	650
CF8M (316 stainless steel)	5 ⁽⁵⁾	8	-198 ⁽³⁾	316	-325 ⁽³⁾	600
	6 ⁽⁵⁾		-198 ⁽³⁾	316	-325 ⁽³⁾	600
	27	All	-198 ⁽³⁾	343	-325 ⁽³⁾	650
	28		-198 ⁽³⁾	149 ⁽⁴⁾	-325 ⁽³⁾	300 ⁽⁴⁾
	29		-198 ⁽³⁾	149 ⁽⁴⁾	-325 ⁽³⁾	300 ⁽⁴⁾

1. For metal trim parts only. Restricted trim and full-sized limits are the same.
 2. Same material also used for bottom flange, if required.
 3. May be used down to -254°C (-425°F) if manufacturing process includes Charpy impact test.
 4. Lubricating service allows usage to 316°C (600°F).
 5. Only available for Whisper Trim I cages.
 6. For Trim 3, upper temperature to 316°C (600°F) when used for Whisper Trim I cages.

Figure 10. WhisperFlo Cage in NPS 4 and 6 Fisher ED Valve

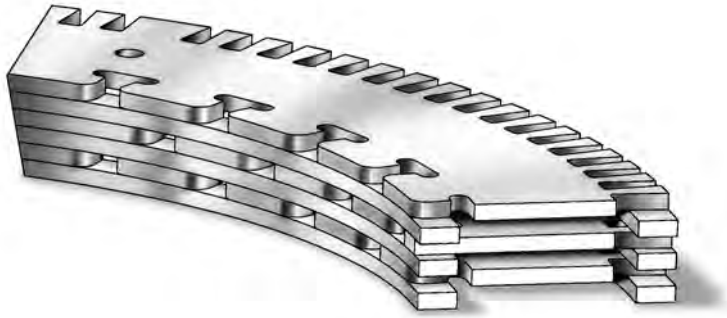

W7065

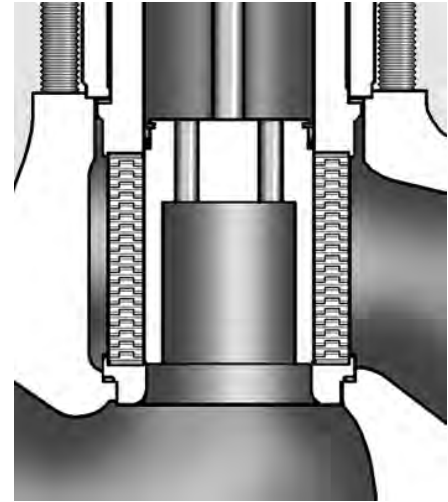

W6851-1

Table 8. Bonnet Selection Guidelines

BONNET STYLE	PACKING MATERIAL	IN-BODY PROCESS TEMPERATURE LIMITS ⁽¹⁾	
		°C	°F
Plain: ■ Standard for all valves through NPS 6 valve body with 2-13/16 yoke boss diameter ■ Standard for NPS 6 and 8 valves in cast iron and WCC steel bonnet material with 3-9/16 yoke boss diameter	PTFE V-ring	-18 to 232	0 to 450
	PTFE/Composition	-18 to 232	0 to 450
	Graphite ribbon/filament	-18 to maximum shown in table 6	0 to maximum shown in table 6
Style 1 Cast Extension: ■ Standard for NPS 8 valves in S31600 bonnet material with 3-9/16 yoke boss diameter	PTFE V-ring	-46 to 427	-50 to 800
	PTFE/Composition		
	Graphite ribbon/filament	-46 to to maximum shown in table 6	-50 to maximum shown in table 6
Style 2 Cast Extension: ■ Optional for NPS 2 through 4 valves with 2-13/16 inch yoke boss diameter ■ Optional for NPS 6 and 8 valves with 3-9/16 yoke boss diameter	PTFE V-ring	-101 to 427	-150 to 800
	PTFE/Composition		
	Graphite ribbon/filament	-101 to maximum shown in table 6	-150 to maximum shown in table 6
ENVIRO-SEAL bellows seal bonnet	PTFE	For exceptional stem sealing capabilities. See Bulletin 59.1:070, ENVIRO-SEAL Bellows Seal Bonnets, for pressure/temperature ratings.	
	Graphite ULF		

1. These in-body process temperatures assume an outside, ambient temperature of 21°C (70°F) and no insulation on the bonnet. When using any packing at low process temperatures, a cast extension bonnet may have to be used to prevent packing damage which could result from the formation of valve stem frost. Material selection for trim and other components will also be limiting factors.

Table 9. Maximum Flow Coefficients for Full-Sized Trim with Equal Percentage Cage and Normal Flow Direction

Valve		Valve Size, NPS	C _v at Max. Valve Plug Travel
ED		1	17.2
		1-1/2	35.8
		2	59.7
		2-1/2	99.4
		3	136
		4	224
		6	394
		8 ⁽¹⁾	567
		8 ⁽²⁾	819
		EAD	with liner
2	48.1		
3	149		
4	152		
6	336		
without liner	1		19.0
	2		47.2
	3		148
	4		156
	6		328
EDR		1	17.2
		1-1/2	35.8
		2	59.7
		2-1/2	99.4
		3	136
		4	224

1. With 51 mm (2 inch) travel.
2. With 76 mm (3 inch) travel.

Table 10. Metal Trim Part Materials for Compatibility with NACE MR0175 / ISO 15156 and MR0103 (Sour Service) Specifications, Environmental Restrictions Apply, Refer to Standard. Contact your [Emerson sales office](#) for information on NACE MR0175 / ISO 15156 and NACE MR0103.

Trim Designation	Valve Plug	Cage	Seat Ring for Standard Metal Seat Construction	Optional Liner for Metal Seat (EAD only)	Valve Stem, Packing Follower, Lantern Ring, Packing Box Ring, and Pin	Load Ring ⁽¹⁾
85 ⁽²⁾	S31600	316 SST with electroless nickel coating (ENC)	S31600	S31600	S20910 (Valve Stem) S31600 (All Other Parts)	N05500
86 ⁽²⁾	S31600 with seat hard faced with CoCr-A hardfacing alloy	316 SST with electroless nickel coating (ENC)	R30006 (alloy 6)	---		
87	S31600 with seat and guide hard faced with CoCr-A hardfacing alloy	316 SST with electroless nickel coating (ENC)	R30006 (alloy 6)	---		

1. NPS 8 valve only.
2. Not use with Whisper Trim I with 136 mm (5.375 inch) and larger ports.

Table 11. Port Diameters, Valve Plug Travel, and Stem and Yoke Boss Diameters

VALVE SIZE, NPS				PORT DIAMETER		MAX VALVE PLUG TRAVEL		STEM AND YOKE BOSS DIAMETERS							
ED or EDR		EAD						Standard				Optional			
Full-Sized Trim	Restricted-Capacity Trim	Full-Sized Trim	Restricted-Capacity Trim	mm	Inch	mm	Inch	mm	Inch	mm	Inch	mm	Inch	mm	Inch
1	1-1/2	1	2	33.3	1.3125	19	0.75	9.5	3/8	54	2-1/8	12.7	1/2	71	2-13/16
---	2	---	---	33.3	1.3125	19	0.75	12.7	1/2	71	2-13/16	---	---	---	---
1-1/2	---	2	---	47.6	1.875	19	0.75	9.5	3/8	54	2-1/8	12.7	1/2	71	2-13/16
---	2-1/2	---	3	47.6	1.875	19	0.75	1.7	1/2	71	2-13/16	---	---	---	---
2	3	---	4	58.7	2.3125	29	1.125	12.7	1/2	71	2-13/16	19.1	3/4	90	3-9/16
2-1/2	4	3	6	73.0	2.875	38	1.5	12.7	1/2	71	2-13/16	19.1	3/4	90	3-9/16
3	---	4	---	87.3	3.4375	38	1.5	12.7	1/2	71	2-13/16	19.1	3/4	90	3-9/16
4	---	6	---	87 ⁽³⁾	3.4375 ⁽³⁾	76 ⁽³⁾	3 ⁽³⁾	12.7	1/2	71	2-13/16	19.1	3/4	90	3-9/16
				111.1	4.375	51	2					25.4	1	127	5
6 ⁽¹⁾	---	---	---	177.8 ⁽²⁾	7 ⁽²⁾	51 ⁽²⁾	2 ⁽²⁾	19.1	3/4	90	3-9/16	25.4	1	127	5
				136 ⁽³⁾	5.375 ⁽³⁾	76 ⁽³⁾	3 ⁽³⁾					25.4 or 31.8	1 or 1-1/4	127	5
8 ⁽¹⁾	---	---	---	203.2	8	76	3								

1. Not available in EDR valve.
2. Standard-travel cages.
3. WhisperFlo cages (NPS 4 and 6 ED).

Table 12. Port Diameter, Valve Plug Travel, and Stem and Yoke Boss Diameters for Whisper III Trims⁽¹⁾ and Whisper NXG Trim

VALVE SIZE, NPS		PORT DIAMETER		MAX VALVE PLUG TRAVEL		STEM AND YOKE BOSS DIAMETERS								PERFORMANCE LEVEL
ED	EAD	mm	Inch	mm	Inch	Standard				Optional				
						Stem		Yoke Boss		Stem		Yoke Boss		
						mm	Inch	mm	Inch	mm	Inch	mm	Inch	
1	1	33.3	1 5/16	19	3/4	9.5	3/8	54	2 1/8	12.7	1/2	71	2 13/16	A1
1 1/2	2	47.6	1 7/8	19	3/4	9.5	3/8	54	2 1/8	12.7	1/2	71	2 13/16	A1
		33.3	1 5/16	19	3/4									A3, B1, B3
2	--	58.7	2 5/16	35	1 3/8	12.7	1/2	71	2 13/16	19.1	3/4	90	3 9/16	A1
		33.3	1 5/16	29	1 1/8									A3, B1, B3, C1, C3, D1, D3
2 1/2	3	73.0	2 7/8	38	1 1/2	12.7	1/2	71	2 13/16	19.1	3/4	90	3 9/16	A1
		47.6	1 7/8											A3, B1, B3, C1, C3, D1, D3
3	4	87.3	3 7/16	38	1 1/2	12.7	1/2	71	2 13/16	19.1	3/4	90	3 9/16	A1
		58.7	2 5/16											A3, B1, B3, C1, C3, D1, D3
4	6	111.1	4 3/8	51	2	12.7	1/2	71	2 13/16	19.1	3/4	90	3 9/16	A1
		87.3	3 7/16							25.4	1	127	5	A3, B1, B3, C1, C3, D1, D3
6	--	177.8	7	51	2	19.1	3/4	90	3 9/16	25.4 or 31.8	1 or 1 1/4	127	5	A1
		136.5	5 3/8	76	3									A3, B1, B3, C1, C3, D1, D3
8	--	203.2	8	76	3	19.1	3/4	90	3 9/16	25.4 or 31.8	1 or 1 1/4	127	5	A1
				102	4									A3, B1, B3, C1, C3

1. Refer Fisher Bulletin 80.1:010 Whisper Trim III (D100191X012) for more information.

Table 13. Bolting Materials and Temperature Limits for Compatibility with NACE MR0175-2002, NACE MR0175/ISO 15156, and NACE MR0103. Environmental restrictions may apply

VALVE BODY MATERIAL	BOLTING MATERIAL	TEMPERATURE CAPABILITIES					
		°C		°F			
		Min	Max	Min	Max		
Non-exposed bolting (Standard)							
WCC and CF8M (316 SST)	Studs	Steel SA-193-B7		-48 ⁽²⁾	427	-55 ⁽²⁾	800
	Nuts	Steel SA-194-2H					
Exposed bolting (Optional) Requires Derating of Valve ⁽¹⁾ When These Body-to-Bonnet Bolting Materials are Used							
WCC and CF8M	Studs	Steel SA-193-B7M		-48 ⁽²⁾	427	-55 ⁽²⁾	800
	Nuts	Steel SA-194-2HM					

1. Derating is not required for CL300 valves. Derating may be required for valves rated at CL600. Contact your [Emerson sales office](#) for assistance in determining the derating of valves when these body-to-bonnet bolting materials are used.
2. -29°C (-20°F) with WCC valve body material.

Figure 11. Typical Trim Used for NACE MR0175 / ISO 15156 and NACE MR0103. Environmental restrictions may apply

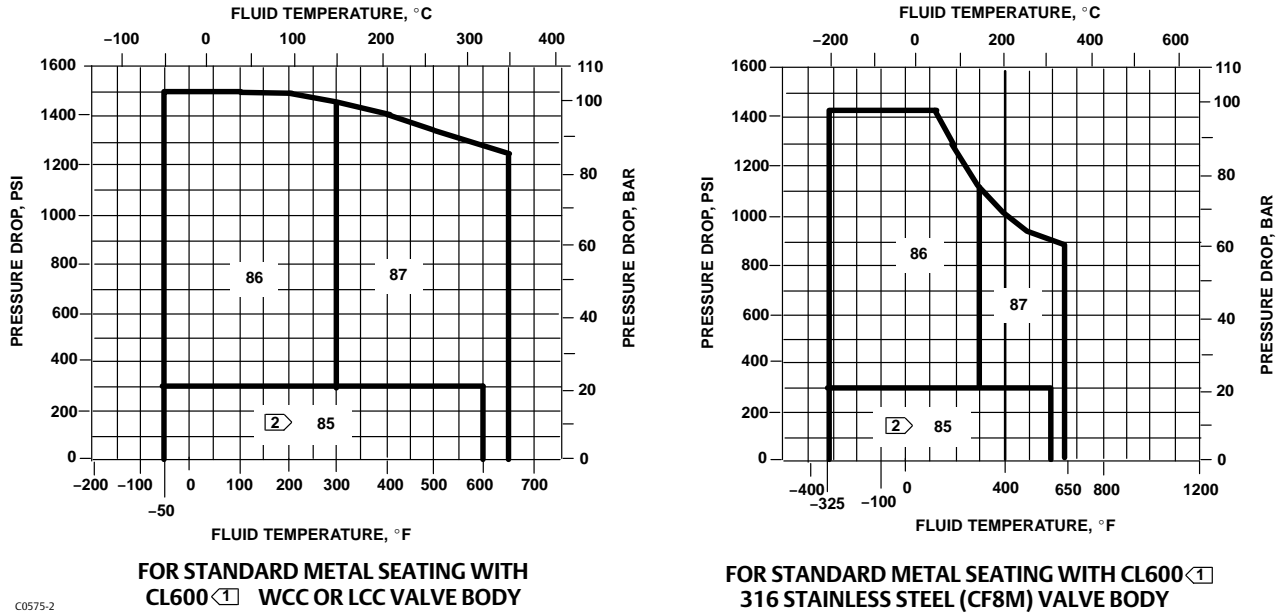

Notes:

- ① Do not exceed the maximum pressure and temperature for the pressure rating of the valve material used, even though the trim shown may have higher capabilities.
- ② Use trim 87 instead of trim 85 for nonlubricating fluids such as superheated steam or dry gases between 149 and 316°C (300 and 600°F).

Table 14. Fisher ED and EDR Dimensions

VALVE SIZE, NPS	A Pressure Rating, End Connection Style ⁽¹⁾									G (MAX)	
	Scrd or SW	CL125 FF or 150 RF	CL150 RTJ	CL250 RF or 300 RF	CL300 RTJ	BW or CL600 RF	CL600 RTJ	PN16-40 ⁽²⁾	PN63-100 ⁽²⁾	ED	EDR
	mm										
1	210	184	197	197	210	210	210	160	230	60	119
1-1/2	251	222	235	235	248	251	251	200	260	71	116
2	286	254	267	267	282	286	289	230	300	78	133
2-1/2	---	276	292	292	308	311	314	290	340	90	159
3	---	298	311	317	333	337	340	310	380	97	168
4	---	353	365	368	384	394	397	350	430	129	192
6	---	451	464	473	489	508	511	480	550	140	---
8	---	543	556	568	584	610	613	600	650	191	---
	Inch										
1	8.25	7.25	7.75	7.75	8.25	8.25	8.25			2.38	4.69
1-1/2	9.88	8.75	9.25	9.25	9.75	9.88	9.88			2.81	4.56
2	11.25	10.00	10.50	10.50	11.12	11.25	11.38			3.06	5.25
2-1/2	---	10.88	11.38	11.50	12.12	12.25	12.38	See mm below	See mm below	3.56	6.25
3	---	11.75	12.25	12.50	13.12	13.25	13.38			3.81	6.62
4	---	13.88	14.38	14.50	15.12	15.50	15.62			5.06	7.56
6	---	17.75	18.25	18.62	19.25	20.00	20.12			5.51	---
8	---	21.38	21.88	22.38	23.00	24.00	24.12			7.50	---

1. End connection style abbreviations: BW - Butt welding, FF - Flat Faced, Scrd - Screwed, SW - Socket weld, RF - Raised Face, RTJ - Ring Type Joint.
 2. Valves which meet EN flange standards and have EN face-to-face dimensions are available only from Europe. Valves which meet EN flange standards but not EN face-to-face standards are available in the US. Consult your [Emerson sales office](#).

Figure 12. Fisher ED and EDR Dimensions (also see tables 14, 15, and 16)

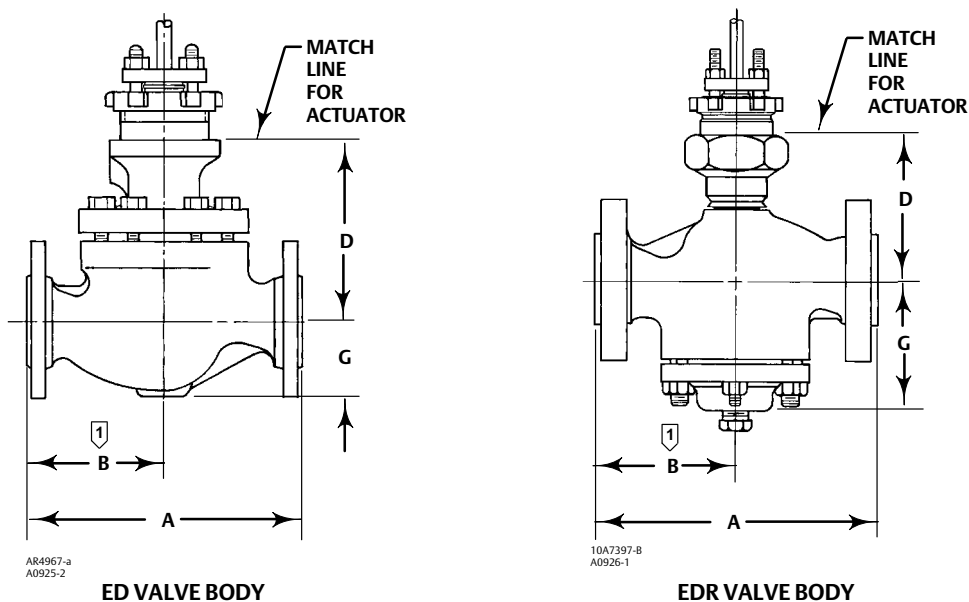

Notes:
① B = $\frac{A}{2}$

Table 15. Fisher ED and EDR Dimensions

VALVE SIZE, NPS	D FOR PLAIN BONNET						
	ED				EDR		
	Stem Diameter				Stem Diameter		
	mm						
	9.5	12.7	19.1	25.4 or 31.8	9.5	12.7	19.1
1	127	149	---	---	113	124	---
1-1/2	124	146	---	---	122	133	---
2	---	165	162	---	---	148	140
2-1/2	---	187	184	---	---	157	152
3	---	191	187	---	---	167	159
4	---	221	217	264	---	198	191
6 ⁽¹⁾	---	---	251	270	---	---	---
6 ⁽²⁾	---	---	312	330	---	---	---
8	---	---	375 ⁽³⁾	---	---	---	---
	Inch						
	3/8	1/2	3/4	1 or 1-1/4	3/8	1/2	3/4
1	5.00	5.88	---	---	4.44	4.88	---
1-1/2	4.88	5.75	---	---	4.81	5.25	---
2	---	6.50	6.38	---	---	5.81	5.50
2-1/2	---	7.38	7.25	---	---	6.31	6.00
3	---	7.50	7.38	---	---	6.56	6.25
4	---	8.69	8.56	10.38	---	7.81	7.50
6 ⁽¹⁾	---	---	9.88	10.62	---	---	---
6 ⁽²⁾	---	---	12.26	13.00	---	---	---
8	---	---	14.75 ⁽³⁾	---	---	---	---

1. For all NPS 6 valves except with Whisper Trim III, Whisper NXG Trim and WhisperFlo cages.
 2. For NPS 6 valves with Whisper Trim III, Whisper NXG Trim, and WhisperFlo Cages.
 3. Available only in cast iron or WCC steel for the stem diameter with plain bonnet.

Table 16. Fisher ED and EDR Dimensions

VALVE SIZE, NPS	D FOR EXTENSION AND ENVIRO-SEAL BELLOWS SEAL BONNETS (ED ONLY)									
	Style 1 Ext. Bonnet				Style 2 Ext. Bonnet			ENVIRO-SEAL Bellows Seal Bonnet		
	Stem Diameter				Stem Diameter			Stem Diameter		
	mm									
	9.5	12.7	19.1	25.4 or 31.8	9.5	12.7	19.1	9.5	12.7	19.1
1	213	251	---	---	303	319	---	321	---	---
1-1/2	210	248	---	---	300	316	---	317	---	---
2	---	267	---	---	---	465	---	---	384	---
2-1/2	---	289	272	---	---	492	---	---	---	---
3	---	292	297	---	---	495	487	---	518	518
4	---	322	327	370	---	526	518	---	541	---
6 ⁽¹⁾	---	---	357	402	---	---	543	---	---	573
6 ⁽²⁾	---	---	418	462	---	---	604	---	---	---
8	---	---	421	450	---	---	621	---	---	---
	Inch									
	3/8	1/2	3/4	1 or 1-1/4	3/8	1/2	3/4	3/8	1/2	3/4
1	8.38	9.88	---	---	11.94	12.56	---	12.62	---	---
1-1/2	8.25	9.75	---	---	11.81	12.44	---	12.50	---	---
2	---	10.50	---	---	---	18.31	---	---	15.12	---
2-1/2	---	11.38	10.69	---	---	19.38	---	---	---	---
3	---	11.50	11.69	---	---	19.50	19.19	---	20.38	20.38
4	---	12.69	12.88	14.56	---	20.69	20.38	---	21.31	---
6 ⁽¹⁾	---	---	14.06	15.81	---	---	21.38	---	---	22.56
6 ⁽²⁾	---	---	16.44	18.19	---	---	23.76	---	---	---
8	---	---	16.56	17.75	---	---	24.44	---	---	---

1. Standard-travel cages.
2. For NPS 6 valves with Whisper Trim III, Whisper NXG Trim, and WhisperFlo Cages.

Table 17. Fisher EAD Dimensions

VALVE SIZE, NPS	AA					
	CL150		CL300		CL600	
	End Connection Style ⁽¹⁾					
	RF	RTJ	RF	RTJ	BW, SW or RF	RTJ
mm						
1	92	98	98	105	105	105
2	127	133	133	141	143	144
3	149	156	159	167	168	170
4	176	183	184	197	197	198
6	225	232	237	244	254	256
	Inch					
1	3.62	3.88	3.88	4.12	4.12	4.12
2	5.00	5.25	5.25	5.56	5.62	5.69
3	5.88	6.12	6.25	6.56	6.62	6.69
4	6.94	7.19	7.25	7.56	7.75	7.81
6	8.88	9.12	9.31	9.62	10.00	10.06

1. End connection style abbreviations: BW - Butt-welding, FF - Flat Faced, Scrd - Screwed, SW - Socketweld, RF - Raised Face, RTJ - Ring Type Joint.

Figure 13. Fisher EAD Dimensions (also see tables 17 and 18)

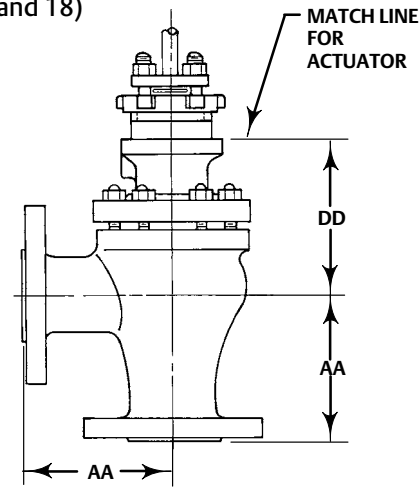

AUG190-A
A0927-2

Note:
For dimensions of valves with EN (or other) end connections, consult your [Emerson sales office](#).

Table 18. Fisher EAD Dimensions

VALVE SIZE, NPS	DD										ENVIRO-SEAL Bellows Seal Bonnet
	Plain Bonnet				Style 1 Extension Bonnet			Style 2 Extension Bonnet			
	Stem Diameter										
	mm										
	9.5	12.7	19.1	25.4 or 31.8	9.5	12.7	19.1	9.5	12.7	19.1	
1	111	133	---	---	197	235	---	291	305	---	Contact your Emerson sales office
2	98	121	---	---	184	223	---	278	291	---	
3	---	149	146	---	---	251	256	---	454	---	
4	---	140	137	---	---	241	246	---	445	437	
6	---	144	141	187	---	246	251	---	449	441	
	Inch										ENVIRO-SEAL Bellows Seal Bonnet
	3/8	1/2	3/4	1 or 1-1/4	3/8	1/2	3/4	3/8	1/2	3/4	
	1	4.38	5.25	---	---	7.75	9.25	---	11.44	12.00	
2	3.88	4.75	---	---	7.25	8.75	---	10.94	11.44	---	
3	---	5.88	5.75	---	---	9.88	10.06	---	17.88	---	
4	---	5.50	5.38	---	---	9.50	9.69	---	17.50	17.19	
6	---	5.69	5.56	7.38	---	9.69	9.88	---	17.69	17.38	

Product Bulletin

51.1:ED
October 2023

ED Valve
D100017X012

Neither Emerson, nor any of their affiliated entities assumes responsibility for the selection, use or maintenance of any product. Responsibility for proper selection, use, and maintenance of any product remains solely with the purchaser and end user.

Fisher, easy-e, Whisper Trim, WhisperFlo, and ENVIRO-SEAL are marks owned by one of the companies in the Emerson business unit of Emerson Electric Co. Emerson, and the Emerson logo are trademarks and service marks of Emerson Electric Co. All other marks are the property of their respective owners.

The contents of this publication are presented for informational purposes only, and while every effort has been made to ensure their accuracy, they are not to be construed as warranties or guarantees, express or implied, regarding the products or services described herein or their use or applicability. All sales are governed by our terms and conditions, which are available upon request. We reserve the right to modify or improve the designs or specifications of such products at any time without notice.

Emerson

Marshalltown, Iowa 50158 USA
Sorocaba, 18087 Brazil
Cernay, 68700 France
Dubai, United Arab Emirates
Singapore 128461 Singapore

www.Fisher.com

