

# Technical Information

## Proline Promass E 100

Coriolis flowmeter



The flowmeter with minimized total cost of ownership and an ultra-compact transmitter

### Application

- Measuring principle operates independently of physical fluid properties such as viscosity or density
- Highly accurate measurement of liquids and gases for a wide range of standard applications

### Device properties

- Compact dual-tube system
- Medium temperature up to +140 °C (+284 °F)
- Process pressure up to 100 bar (1450 psi)
- Robust, ultra-compact transmitter housing
- Highest degree of protection: IP69K
- Local display available

### Your benefits

- Cost-effective – multi-purpose device; an alternative to conventional volumetric flowmeters
- Fewer process measuring points – multivariable measurement (flow, density, temperature)
- Space-saving installation – no in/outlet run needs
- Space-saving transmitter – full functionality on smallest footprint
- Time-saving local operation without additional software and hardware – integrated web server
- Integrated verification – Heartbeat Technology™

## Table of contents







<b>Document information</b> . . . . .	<b>4</b>	Shock resistance . . . . .	41
Symbols used . . . . .	4	Vibration resistance . . . . .	41
<b>Function and system design</b> . . . . .	<b>5</b>	Interior cleaning . . . . .	41
Measuring principle . . . . .	5	Electromagnetic compatibility (EMC) . . . . .	42
Measuring system . . . . .	6	<b>Process</b> . . . . .	<b>42</b>
Device architecture . . . . .	7	Medium temperature range . . . . .	42
Safety . . . . .	7	Density . . . . .	42
<b>Input</b> . . . . .	<b>7</b>	Pressure-temperature ratings . . . . .	42
Measured variable . . . . .	7	Secondary containment pressure rating . . . . .	45
Measuring range . . . . .	8	Rupture disk . . . . .	45
Operable flow range . . . . .	8	Flow limit . . . . .	46
<b>Output</b> . . . . .	<b>9</b>	Pressure loss . . . . .	46
Output signal . . . . .	9	System pressure . . . . .	46
Signal on alarm . . . . .	10	Thermal insulation . . . . .	46
Ex connection data . . . . .	12	Heating . . . . .	47
Low flow cut off . . . . .	12	Vibrations . . . . .	47
Galvanic isolation . . . . .	13	<b>Mechanical construction</b> . . . . .	<b>48</b>
Protocol-specific data . . . . .	13	Design, dimensions . . . . .	48
<b>Power supply</b> . . . . .	<b>18</b>	Weight . . . . .	65
Terminal assignment . . . . .	18	Materials . . . . .	65
Pin assignment, device plug . . . . .	24	Process connections . . . . .	67
Supply voltage . . . . .	26	<b>Operability</b> . . . . .	<b>67</b>
Power consumption . . . . .	26	Operating concept . . . . .	67
Current consumption . . . . .	27	Local display . . . . .	68
Power supply failure . . . . .	27	Remote operation . . . . .	68
Electrical connection . . . . .	27	Service interface . . . . .	69
Potential equalization . . . . .	31	<b>Certificates and approvals</b> . . . . .	<b>71</b>
Terminals . . . . .	31	CE mark . . . . .	71
Cable entries . . . . .	32	C-Tick symbol . . . . .	71
Cable specification . . . . .	32	Ex approval . . . . .	72
<b>Performance characteristics</b> . . . . .	<b>33</b>	Hygienic compatibility . . . . .	72
Reference operating conditions . . . . .	33	Certification PROFIBUS . . . . .	72
Maximum measured error . . . . .	33	Modbus RS485 certification . . . . .	72
Repeatability . . . . .	35	EtherNet/IP certification . . . . .	72
Response time . . . . .	35	Pressure Equipment Directive . . . . .	72
Influence of ambient temperature . . . . .	35	Other standards and guidelines . . . . .	73
Influence of medium temperature . . . . .	35	<b>Ordering information</b> . . . . .	<b>73</b>
Influence of medium pressure . . . . .	36	<b>Application packages</b> . . . . .	<b>74</b>
Design fundamentals . . . . .	36	Heartbeat Technology . . . . .	74
<b>Installation</b> . . . . .	<b>37</b>	Concentration . . . . .	74
Mounting location . . . . .	37	<b>Accessories</b> . . . . .	<b>74</b>
Orientation . . . . .	38	Device-specific accessories . . . . .	74
Inlet and outlet runs . . . . .	38	Communication-specific accessories . . . . .	75
Special mounting instructions . . . . .	38	Service-specific accessories . . . . .	75
Mounting Safety Barrier Promass 100 . . . . .	39	System components . . . . .	76
<b>Environment</b> . . . . .	<b>39</b>	<b>Documentation</b> . . . . .	<b>76</b>
Ambient temperature range . . . . .	39	Standard documentation . . . . .	76
Storage temperature . . . . .	41	Supplementary device-dependent documentation . . . . .	76
Climate class . . . . .	41		
Degree of protection . . . . .	41		

**Registered trademarks . . . . . 77**









## Document information

### Symbols used

#### Electrical symbols



Symbol	Meaning
	<b>Direct current</b> A terminal to which DC voltage is applied or through which direct current flows.
	<b>Alternating current</b> A terminal to which alternating voltage is applied or through which alternating current flows.
	<b>Direct current and alternating current</b> <ul style="list-style-type: none"> <li>▪ A terminal to which alternating voltage or DC voltage is applied.</li> <li>▪ A terminal through which alternating current or direct current flows.</li> </ul>
	<b>Ground connection</b> A grounded terminal which, as far as the operator is concerned, is grounded via a grounding system.
	<b>Protective ground connection</b> A terminal which must be connected to ground prior to establishing any other connections.
	<b>Equipotential connection</b> A connection that has to be connected to the plant grounding system: This may be a potential equalization line or a star grounding system depending on national or company codes of practice.

#### Symbols for certain types of information

Symbol	Meaning
	<b>Permitted</b> Indicates procedures, processes or actions that are permitted.
	<b>Preferred</b> Indicates procedures, processes or actions that are preferred.
	<b>Forbidden</b> Indicates procedures, processes or actions that are forbidden.
	<b>Tip</b> Indicates additional information.
	<b>Reference to documentation</b> Refers to the corresponding device documentation.
	<b>Reference to page</b> Refers to the corresponding page number.
	<b>Reference to graphic</b> Refers to the corresponding graphic number and page number.
	<b>Visual inspection</b>

#### Symbols in graphics

Symbol	Meaning
1, 2, 3,...	Item numbers
1., 2., 3. ...	Series of steps
A, B, C, ...	Views
A-A, B-B, C-C, ...	Sections
	Flow direction

Symbol	Meaning
	<b>Hazardous area</b> Indicates a hazardous area.
	<b>Safe area (non-hazardous area)</b> Indicates the non-hazardous area.

## Function and system design

### Measuring principle

The measuring principle is based on the controlled generation of Coriolis forces. These forces are always present in a system when both translational and rotational movements are superimposed.

$$F_c = 2 \cdot \Delta m (v \cdot \omega)$$

$$F_c = \text{Coriolis force}$$

$$\Delta m = \text{moving mass}$$

$$\omega = \text{rotational velocity}$$

$$v = \text{radial velocity in rotating or oscillating system}$$

The amplitude of the Coriolis force depends on the moving mass  $\Delta m$ , its velocity  $v$  in the system and thus on the mass flow. Instead of a constant rotational velocity  $\omega$ , the sensor uses oscillation.

In the sensor, two parallel measuring tubes containing flowing fluid oscillate in antiphase, acting like a tuning fork. The Coriolis forces produced at the measuring tubes cause a phase shift in the tube oscillations (see illustration):

- At zero flow (when the fluid is at a standstill) the two tubes oscillate in phase (1).
- Mass flow causes deceleration of the oscillation at the inlet of the tubes (2) and acceleration at the outlet (3).

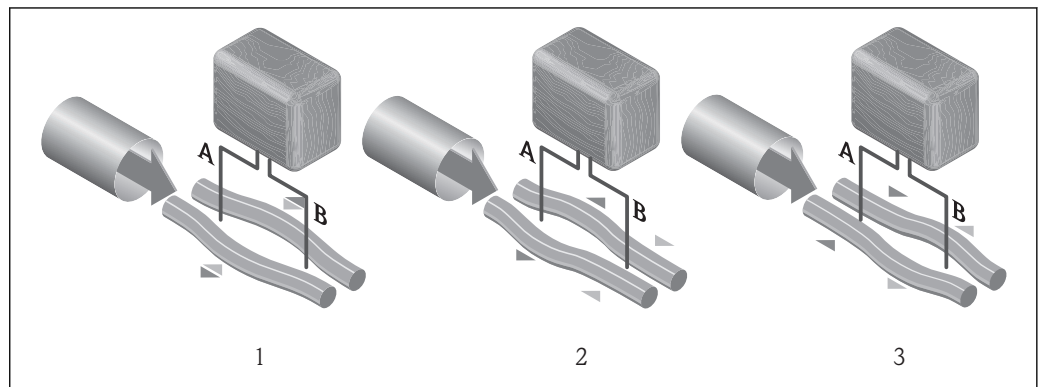

A0016771

The phase difference (A-B) increases with increasing mass flow. Electrodynamical sensors register the tube oscillations at the inlet and outlet. System balance is ensured by the antiphase oscillation of the two measuring tubes. The measuring principle operates independently of temperature, pressure, viscosity, conductivity and flow profile.

### Density measurement

The measuring tube is continuously excited at its resonance frequency. A change in the mass and thus the density of the oscillating system (comprising measuring tube and fluid) results in a corresponding, automatic adjustment in the oscillation frequency. Resonance frequency is thus a function of medium density. The microprocessor utilizes this relationship to obtain a density signal.

### Volume measurement

Together with the measured mass flow, this is used to calculate the volume flow.

**Temperature measurement**

The temperature of the measuring tube is determined in order to calculate the compensation factor due to temperature effects. This signal corresponds to the process temperature and is also available as an output signal.

**Measuring system**

The device consists of a transmitter and a sensor. If a device with Modbus RS485 intrinsically safe is ordered, the Safety Barrier Promass 100 is part of the scope of supply and must be implemented to operate the device.

One device version is available: compact version, transmitter and sensor form a mechanical unit.

**Transmitter**

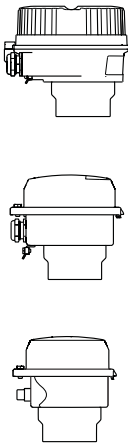
<p><b>Promass 100</b></p>  <p>A0016693</p> <p>A0016694</p> <p>A0016695</p>	<p>Device versions and materials:</p> <ul style="list-style-type: none"> <li>■ Compact, aluminum coated: Aluminum, AlSi10Mg, coated</li> <li>■ Compact, hygienic, stainless: Hygienic version, stainless steel 1.4301 (304)</li> <li>■ Ultra compact, hygienic, stainless: Hygienic version, stainless steel 1.4301 (304)</li> </ul> <p>Configuration:</p> <ul style="list-style-type: none"> <li>■ Via operating tools (e.g. FieldCare)</li> <li>■ Additionally for device version with onsite display: Via Web browser (e.g. Microsoft Internet Explorer)</li> <li>■ Also for device version with 4-20 mA HART, pulse/frequency/switch output: Via Web browser (e.g. Microsoft Internet Explorer)</li> <li>■ Also for device version with EtherNet/IP output:             <ul style="list-style-type: none"> <li>- Via Web browser (e.g. Microsoft Internet Explorer)</li> <li>- Via Add-on Profile Level 3 for automation system from Rockwell Automation</li> <li>- Via Electronic Data Sheet (EDS)</li> </ul> </li> </ul>
--	--

**Sensor**

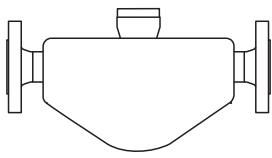
<p><b>Promass E</b></p>  <p>A0013472</p>	<ul style="list-style-type: none"> <li>■ For standard applications where stable and reliable measurements are required</li> <li>■ Simultaneous measurement of flow, volume flow, density and temperature (multivariable)</li> <li>■ Immune to process influences</li> <li>■ Nominal diameter range: DN 8 to 80 (3/8 to 3")</li> <li>■ Materials:             <ul style="list-style-type: none"> <li>- Sensor: stainless steel, 1.4301 (304)</li> <li>- Measuring tubes: stainless steel, 1.4539 (904L)</li> <li>- Process connections: stainless steel, 1.4404 (316/316L)</li> </ul> </li> </ul>
---	--

**Safety Barrier Promass 100**

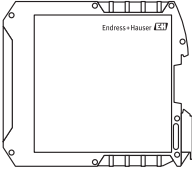
 <p>A0016763</p>	<ul style="list-style-type: none"> <li>■ Dual-channel safety barrier for installation in non-hazardous locations or Zone 2/Div. 2:             <ul style="list-style-type: none"> <li>- Channel 1: DC 24 V power supply</li> <li>- Channel 2: Modbus RS485</li> </ul> </li> <li>■ In addition to current, voltage and power limitation, it offers galvanic isolation of circuits for explosion protection.</li> <li>■ Easy DIN rail mounting (DIN 35mm) for installation in control cabinets</li> </ul>
---	---

Device architecture

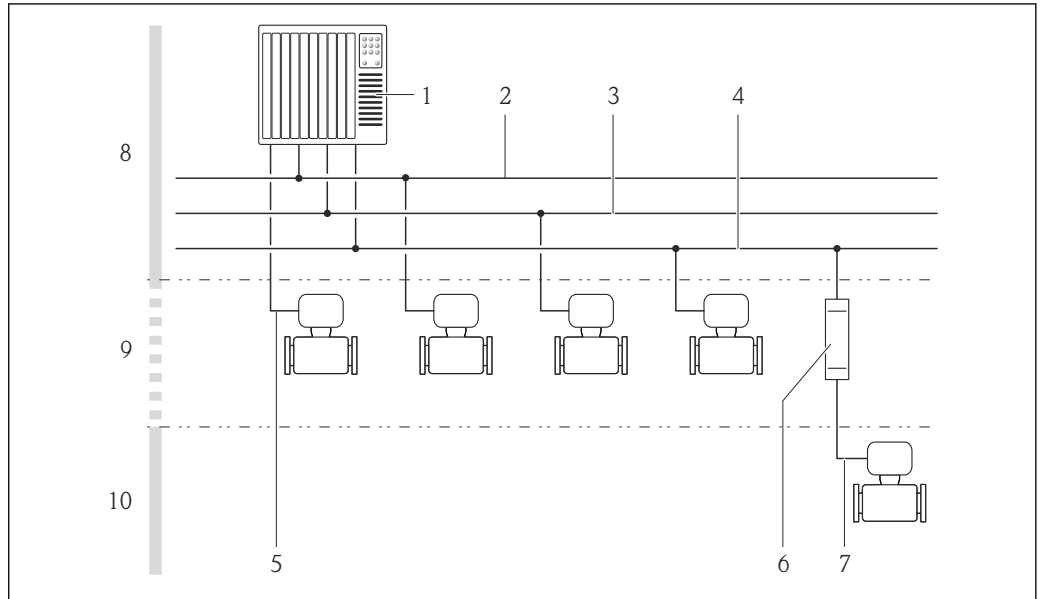

A0016779

1 Possibilities for integrating measuring devices into a system

- 1 Control system (e.g. PLC)
- 2 EtherNet/IP
- 3 PROFIBUS DP
- 4 Modbus RS485
- 5 4-20 mA HART, pulse/frequency/switch output
- 6 Safety Barrier Promass 100
- 7 Modbus RS485 intrinsically safe
- 8 Non-hazardous area
- 9 Non-hazardous area and Zone 2/Div. 2
- 10 Intrinsically safe area and Zone 1/Div. 1

Safety

IT security

We only provide a warranty if the device is installed and used as described in the Operating Instructions. The device is equipped with security mechanisms to protect it against any inadvertent changes to the device settings.

IT security measures in line with operators' security standards and designed to provide additional protection for the device and device data transfer must be implemented by the operators themselves.

Input

Measured variable

Direct measured variables

- Mass flow
- Density
- Temperature

Calculated measured variables

- Volume flow
- Corrected volume flow
- Reference density

## Measuring range

## Measuring ranges for liquids

DN		Measuring range full scale values $\dot{m}_{\min(F)}$ to $\dot{m}_{\max(F)}$	
[mm]	[in]	[kg/h]	[lb/min]
8	$\frac{3}{8}$	0 to 2 000	0 to 73.50
15	$\frac{1}{2}$	0 to 6 500	0 to 238.9
25	1	0 to 18 000	0 to 661.5
40	$1\frac{1}{2}$	0 to 45 000	0 to 1 654
50	2	0 to 70 000	0 to 2 573
80	3	0 to 180 000	0 to 6 615



## Measuring ranges for gases

The full scale values depend on the density of the gas and can be calculated with the formula below:

$$\dot{m}_{\max(G)} = \dot{m}_{\max(F)} \cdot \rho_G \cdot x$$

$\dot{m}_{\max(G)}$	Maximum full scale value for gas [kg/h]
$\dot{m}_{\max(F)}$	Maximum full scale value for liquid [kg/h]
$\dot{m}_{\max(G)} < \dot{m}_{\max(F)}$	$\dot{m}_{\max(G)}$ can never be greater than $\dot{m}_{\max(F)}$
$\rho_G$	Gas density in [kg/m <sup>3</sup> ] at operating conditions

DN		x
[mm]	[in]	[kg/m <sup>3</sup> ]
8	$\frac{3}{8}$	85
15	$\frac{1}{2}$	110
25	1	125
40	$1\frac{1}{2}$	125
50	2	125
80	3	155

 To calculate the measuring range, use the *Applicator* sizing tool (→  75)

## Calculation example for gas

- Sensor: Promass E, DN 50
- Gas: Air with a density of 60.3 kg/m<sup>3</sup> (at 20 °C and 50 bar)
- Measuring range (liquid): 70 000 kg/h
- x = 125 kg/m<sup>3</sup> (for Promass E, DN 50)

Maximum possible full scale value:

$$\dot{m}_{\max(G)} = \dot{m}_{\max(F)} \cdot \rho_G \cdot x = 70\,000 \text{ kg/h} \cdot 60.3 \text{ kg/m}^3 : 125 \text{ kg/m}^3 = 33\,800 \text{ kg/h}$$

## Recommended measuring range

"Flow limit" section (→  46)

## Operable flow range

Over 1000 : 1.

Flow rates above the preset full scale value are not overridden by the electronics unit, with the result that the totalizer values are registered correctly.



## Output

### Output signal

#### Current output

<b>Current output</b>	4-20 mA HART (active)
<b>Maximum output values</b>	<ul style="list-style-type: none"> <li>▪ DC 24 V (no flow)</li> <li>▪ 22.5 mA</li> </ul>
<b>Load</b>	0 to 700 Ω
<b>Resolution</b>	0.38 μA
<b>Damping</b>	Adjustable: 0.07 to 999 s
<b>Assignable measured variables</b>	<ul style="list-style-type: none"> <li>▪ Mass flow</li> <li>▪ Volume flow</li> <li>▪ Corrected volume flow</li> <li>▪ Density</li> <li>▪ Reference density</li> <li>▪ Temperature</li> </ul> <p> The range of options increases if the measuring device has one or more application packages.</p>

#### Pulse/frequency/switch output

<b>Function</b>	Can be set to pulse, frequency or switch output
<b>Version</b>	Passive, open collector
<b>Maximum input values</b>	<ul style="list-style-type: none"> <li>▪ DC 30 V</li> <li>▪ 25 mA</li> </ul>
<b>Voltage drop</b>	For 25 mA: ≤ DC 2 V
<b>Pulse output</b>	
<b>Pulse width</b>	Adjustable: 0.05 to 2 000 ms
<b>Maximum pulse rate</b>	10 000 Impulse/s
<b>Pulse value</b>	Adjustable
<b>Assignable measured variables</b>	<ul style="list-style-type: none"> <li>▪ Mass flow</li> <li>▪ Volume flow</li> <li>▪ Corrected volume flow</li> </ul>
<b>Frequency output</b>	
<b>Output frequency</b>	Adjustable: 0 to 10 000 Hz
<b>Damping</b>	Adjustable: 0 to 999 s
<b>Pulse/pause ratio</b>	1:1
<b>Assignable measured variables</b>	<ul style="list-style-type: none"> <li>▪ Mass flow</li> <li>▪ Volume flow</li> <li>▪ Corrected volume flow</li> <li>▪ Density</li> <li>▪ Reference density</li> <li>▪ Temperature</li> </ul> <p> The range of options increases if the measuring device has one or more application packages.</p>
<b>Switch output</b>	
<b>Switching behavior</b>	Binary, conductive or non-conductive
<b>Switching delay</b>	Adjustable: 0 to 100 s

<b>Number of switching cycles</b>	Unlimited
<b>Assignable functions</b>	<ul style="list-style-type: none"> <li>▪ Off</li> <li>▪ On</li> <li>▪ Diagnostic behavior</li> <li>▪ Limit value <ul style="list-style-type: none"> <li>- Mass flow</li> <li>- Volume flow</li> <li>- Corrected volume flow</li> <li>- Density</li> <li>- Reference density</li> <li>- Temperature</li> <li>- Totalizer 1-3</li> </ul> </li> <li>▪ Flow direction monitoring</li> <li>▪ Status <ul style="list-style-type: none"> <li>- Partially filled pipe detection</li> <li>- Low flow cut off</li> </ul> </li> </ul> <p> The range of options increases if the measuring device has one or more application packages.</p>

### PROFIBUS DP

<b>Signal encoding</b>	NRZ code
<b>Data transfer</b>	9.6 kBaud...12 MBaud

### Modbus RS485

<b>Physical interface</b>	In accordance with EIA/TIA-485-A standard
<b>Terminating resistor</b>	<ul style="list-style-type: none"> <li>▪ For device version used in non-hazardous areas or Zone 2/Div. 2: integrated and can be activated via DIP switches on the transmitter electronics module</li> <li>▪ For device version used in intrinsically safe areas: integrated and can be activated via DIP switches on the Safety Barrier Promass 100</li> </ul>

### EtherNet/IP

<b>Standards</b>	In accordance with IEEE 802.3
------------------	-------------------------------

## Signal on alarm

Depending on the interface, failure information is displayed as follows:

### Current output

4-20 mA

<b>Failure mode</b>	Selectable (as per NAMUR recommendation NE 43): <ul style="list-style-type: none"> <li>▪ Minimum value: 3.6 mA</li> <li>▪ Maximum value: 22 mA</li> <li>▪ Defined value: 3.59 to 22.5 mA</li> <li>▪ Actual value</li> <li>▪ Last valid value</li> </ul>
---------------------	---

### HART

<b>Device diagnostics</b>	Device condition can be read out via HART Command 48
---------------------------	--

**Pulse/frequency/switch output**

Pulse output	
Failure mode	Choose from: <ul style="list-style-type: none"> <li>▪ Actual value</li> <li>▪ No pulses</li> </ul>
Frequency output	
Failure mode	Choose from: <ul style="list-style-type: none"> <li>▪ Actual value</li> <li>▪ Defined value: 0 to 12 500 Hz</li> <li>▪ 0 Hz</li> </ul>
Switch output	
Failure mode	Choose from: <ul style="list-style-type: none"> <li>▪ Current status</li> <li>▪ Open</li> <li>▪ Closed</li> </ul>

**PROFIBUS DP**

Status and alarm messages	Diagnostics in accordance with PROFIBUS PA Profile 3.02
---------------------------	---

**Modbus RS485**

Failure mode	Choose from: <ul style="list-style-type: none"> <li>▪ NaN value instead of current value</li> <li>▪ Last valid value</li> </ul>
--------------	---

**EtherNet/IP**

Device diagnostics	Device condition can be read out in Input Assembly
--------------------	--

**Local display**

Plain text display	With information on cause and remedial measures
Backlight	Red backlighting indicates a device error.

 Status signal as per NAMUR recommendation NE 107

**Operating tool**

- Via digital communication:
  - HART protocol
  - PROFIBUS DP
  - Modbus RS485
  - EtherNet/IP
- Via service interface

Plain text display	With information on cause and remedial measures
--------------------	---

 Additional information on remote operation (→  68)

**Web browser**

Plain text display	With information on cause and remedial measures
--------------------	---

**Light emitting diodes (LED)**

<b>Status information</b>	Status indicated by various light emitting diodes The following information is displayed depending on the device version: <ul style="list-style-type: none"> <li>■ Supply voltage active</li> <li>■ Data transmission active</li> <li>■ Device alarm/error has occurred</li> <li>■ EtherNet/IP network available</li> <li>■ EtherNet/IP connection established</li> </ul>
---------------------------	--

**Ex connection data**

These values only apply for the following device version:  
Order code for "Output", option **M**: Modbus RS485, for use in intrinsically safe areas

**Safety Barrier Promass 100***Safety-related values*

Terminal numbers			
Supply voltage		Signal transmission	
2 (L-)	1 (L+)	26 (A)	27 (B)
$U_{nom} = DC\ 24\ V$ $U_{max} = AC\ 260\ V$		$U_{nom} = DC\ 5\ V$ $U_{max} = AC\ 260\ V$	

*Intrinsically safe values*

Terminal numbers			
Supply voltage		Signal transmission	
20 (L-)	10 (L+)	62 (A)	72 (B)
$U_o = 16.24\ V$ $I_o = 623\ mA$ $P_o = 2.45\ W$ For IIC*: $L_o = 92.8\ \mu H$ , $C_o = 0.433\ \mu F$ , $L_o/R_o = 14.6\ \mu H/\Omega$ For IIB*: $L_o = 372\ \mu H$ , $C_o = 2.57\ \mu F$ , $L_o/R_o = 58.3\ \mu H/\Omega$			
* The gas group depends on the sensor and nominal diameter.			
 For an overview and for information on the interdependencies between the gas group - sensor - nominal diameter, see the "Safety Instructions" (XA) document for the measuring device			

**Transmitter***Intrinsically safe values*

Order code for "Approvals"	Terminal numbers			
	Supply voltage		Signal transmission	
	20 (L-)	10 (L+)	62 (A)	72 (B)
<ul style="list-style-type: none"> <li>■ Option <b>BM</b>: ATEX II2G + IECEx Z1 Ex ia, II2D Ex tb</li> <li>■ Option <b>BO</b>: ATEX II1/2G + IECEx Z0/Z1 Ex ia, II2D</li> <li>■ Option <b>BQ</b>: ATEX II1/2G + IECEx Z0/Z1 Ex ia</li> <li>■ Option <b>BU</b>: ATEX II2G + IECEx Z1 Ex ia</li> <li>■ Option <b>C2</b>: CSA C/US IS Cl. I, II, III Div. 1</li> <li>■ Option <b>85</b>: ATEX II2G + IECEx Z1 Ex ia + CSA C/US IS Cl. I, II, III Div. 1</li> </ul>	$U_i = 16.24\ V$ $I_i = 623\ mA$ $P_i = 2.45\ W$ $L_i = 0\ \mu H$ $C_i = 6\ nF$			
 For an overview and for information on the interdependencies between the gas group - sensor - nominal diameter, see the "Safety Instructions" (XA) document for the measuring device				

**Low flow cut off**

The switch points for low flow cut off are user-selectable.

**Galvanic isolation**

The following connections are galvanically isolated from each other:

- Outputs
- Power supply

**Protocol-specific data**

**HART**



<b>Manufacturer ID</b>	0x11
<b>Device type ID</b>	0x4A
<b>HART protocol revision</b>	7.0
<b>Device description files (DTM, DD)</b>	Information and files under: <a href="http://www.endress.com">www.endress.com</a>
<b>HART load</b>	Min. 250 Ω
<b>Dynamic variables</b>	<p>Read out the dynamic variables: HART command 3 The measured variables can be freely assigned to the dynamic variables.</p> <p><b>Measured variables for PV (primary dynamic variable)</b></p> <ul style="list-style-type: none"> <li>▪ Mass flow</li> <li>▪ Volume flow</li> <li>▪ Corrected volume flow</li> <li>▪ Density</li> <li>▪ Reference density</li> <li>▪ Temperature</li> </ul> <p><b>Measured variables for SV, TV, QV (secondary, tertiary and quaternary dynamic variable)</b></p> <ul style="list-style-type: none"> <li>▪ Mass flow</li> <li>▪ Volume flow</li> <li>▪ Corrected volume flow</li> <li>▪ Density</li> <li>▪ Reference density</li> <li>▪ Temperature</li> <li>▪ Totalizer 1</li> <li>▪ Totalizer 2</li> <li>▪ Totalizer 3</li> </ul> <p> The range of options increases if the measuring device has one or more application packages.</p> <p><b>Heartbeat Technology Application Package</b> Additional measured variables are available with the Heartbeat Technology application package:</p> <ul style="list-style-type: none"> <li>▪ Carrier pipe temperature</li> <li>▪ Oscillation amplitude 0</li> </ul>
<b>Device variables</b>	<p>Read out the device variables: HART command 9 The device variables are permanently assigned.</p> <p>A maximum of 8 device variables can be transmitted:</p> <ul style="list-style-type: none"> <li>▪ 0 = mass flow</li> <li>▪ 1 = volume flow</li> <li>▪ 2 = corrected volume flow</li> <li>▪ 3 = density</li> <li>▪ 4 = reference density</li> <li>▪ 5 = temperature</li> <li>▪ 6 = totalizer 1</li> <li>▪ 7 = totalizer 2</li> <li>▪ 8 = totalizer 3</li> <li>▪ 9 = dynamic viscosity</li> <li>▪ 10 = kinematic viscosity</li> <li>▪ 11 = temp. compensated dynamic viscosity</li> <li>▪ 12 = temp. compensated kinematic viscosity</li> <li>▪ 13 = target mass flow</li> <li>▪ 14 = carrier mass flow</li> <li>▪ 15 = concentration</li> </ul>

## PROFIBUS DP

<b>Manufacturer ID</b>	0x11
<b>Ident number</b>	0x1561
<b>Profile version</b>	3.02
<b>Device description files (GSD, DTM, DD)</b>	Information and files under: <ul style="list-style-type: none"> <li>▪ <a href="http://www.endress.com">www.endress.com</a></li> <li>▪ <a href="http://www.profibus.org">www.profibus.org</a></li> </ul>
<b>Output values</b> (from measuring device to automation system)	<p><b>Analog input 1 to 8</b></p> <ul style="list-style-type: none"> <li>▪ Mass flow</li> <li>▪ Volume flow</li> <li>▪ Corrected volume flow</li> <li>▪ Target mass flow</li> <li>▪ Carrier mass flow</li> <li>▪ Density</li> <li>▪ Reference density</li> <li>▪ Concentration</li> <li>▪ Dynamic viscosity</li> <li>▪ Kinematic viscosity</li> <li>▪ Temp. compensated dynamic viscosity</li> <li>▪ Temp. compensated kinematic viscosity</li> <li>▪ Temperature</li> <li>▪ Carrier pipe temperature</li> <li>▪ Electronic temperature</li> <li>▪ Oscillation frequency</li> <li>▪ Oscillation amplitude</li> <li>▪ Frequency fluctuation</li> <li>▪ Oscillation damping</li> <li>▪ Tube damping fluctuation</li> <li>▪ Signal asymmetry</li> <li>▪ Exciter current</li> </ul> <p><b>Digital input 1 to 2</b></p> <ul style="list-style-type: none"> <li>▪ Partially filled pipe detection</li> <li>▪ Low flow cut off</li> </ul> <p><b>Totalizer 1 to 3</b></p> <ul style="list-style-type: none"> <li>▪ Mass flow</li> <li>▪ Volume flow</li> <li>▪ Corrected volume flow</li> </ul>
<b>Input values</b> (from automation system to measuring device)	<p><b>Analog output 1 to 3 (fixed assignment)</b></p> <ul style="list-style-type: none"> <li>▪ Pressure</li> <li>▪ Temperature</li> <li>▪ Reference density</li> </ul> <p><b>Digital output 1 to 3 (fixed assignment)</b></p> <ul style="list-style-type: none"> <li>▪ Digital output 1: switch positive zero return on/off</li> <li>▪ Digital output 2: perform zero point adjustment</li> <li>▪ Digital output 3: switch switch output on/off</li> </ul> <p><b>Totalizer 1 to 3</b></p> <ul style="list-style-type: none"> <li>▪ Totalize</li> <li>▪ Reset and hold</li> <li>▪ Preset and hold</li> <li>▪ Stop</li> <li>▪ Operating mode configuration: <ul style="list-style-type: none"> <li>- Net flow total</li> <li>- Forward flow total</li> <li>- Reverse flow total</li> </ul> </li> </ul>

<b>Supported functions</b>	<ul style="list-style-type: none"> <li>▪ Identification &amp; Maintenance Simplest device identification on the part of the control system and nameplate</li> <li>▪ PROFIBUS upload/download Reading and writing parameters is up to ten times faster with PROFIBUS upload/download</li> <li>▪ Condensed status Simplest and self-explanatory diagnostic information by categorizing diagnostic messages that occur</li> </ul>
<b>Configuration of the device address</b>	<ul style="list-style-type: none"> <li>▪ DIP switches on the I/O electronics module</li> <li>▪ Via operating tools (e.g. FieldCare)</li> </ul>

**Modbus RS485**

Protocol	Modbus Applications Protocol Specification V1.1
Device type	Slave
Slave address range	1 to 247
Broadcast address range	0
Function codes	<ul style="list-style-type: none"> <li>▪ 03: Read holding register</li> <li>▪ 04: Read input register</li> <li>▪ 06: Write single registers</li> <li>▪ 08: Diagnostics</li> <li>▪ 16: Write multiple registers</li> <li>▪ 23: Read/write multiple registers</li> </ul>
Broadcast messages	Supported by the following function codes: <ul style="list-style-type: none"> <li>▪ 06: Write single registers</li> <li>▪ 16: Write multiple registers</li> <li>▪ 23: Read/write multiple registers</li> </ul>
Supported baud rate	<ul style="list-style-type: none"> <li>▪ 1 200 BAUD</li> <li>▪ 2 400 BAUD</li> <li>▪ 4 800 BAUD</li> <li>▪ 9 600 BAUD</li> <li>▪ 19 200 BAUD</li> <li>▪ 38 400 BAUD</li> <li>▪ 57 600 BAUD</li> <li>▪ 115 200 BAUD</li> </ul>
Data transfer mode	<ul style="list-style-type: none"> <li>▪ ASCII</li> <li>▪ RTU</li> </ul>
Data access	Each device parameter can be accessed via Modbus RS485.  For Modbus register information (→  76)

**EtherNet/IP**

Protocol	<ul style="list-style-type: none"> <li>▪ The CIP Networks Library Volume 1: Common Industrial Protocol</li> <li>▪ The CIP Networks Library Volume 2: EtherNet/IP Adaptation of CIP</li> </ul>
Communication type	<ul style="list-style-type: none"> <li>▪ 10Base-T</li> <li>▪ 100Base-TX</li> </ul>
Device profile	Generic device (product type: 0x2B)
Manufacturer ID	0x49E
Device type ID	0x104A
Baud rates	Automatic <sup>10</sup> / <sub>100</sub> Mbit with half-duplex and full-duplex detection
Polarity	Auto-polarity for automatic correction of crossed TxD and RxD pairs
Supported CIP connections	Max. 3 connections
Explicit connections	Max. 6 connections

I/O connections	Max. 6 connections (scanner)		
Configuration options for measuring device	<ul style="list-style-type: none"> <li>▪ DIP switches on the electronics module for IP addressing</li> <li>▪ Manufacturer-specific software (FieldCare)</li> <li>▪ Add-on Profile Level 3 for Rockwell Automation control systems</li> <li>▪ Web browser</li> <li>▪ Electronic Data Sheet (EDS) integrated in the measuring device</li> </ul>		
Configuration of the EtherNet interface	<ul style="list-style-type: none"> <li>▪ Speed: 10 MBit, 100 MBit, auto (factory setting)</li> <li>▪ Duplex: half-duplex, full-duplex, auto (factory setting)</li> </ul>		
Configuration of the device address	<ul style="list-style-type: none"> <li>▪ DIP switches on the electronics module for IP addressing (last octet)</li> <li>▪ DHCP</li> <li>▪ Manufacturer-specific software (FieldCare)</li> <li>▪ Add-on Profile Level 3 for Rockwell Automation control systems</li> <li>▪ Web browser</li> <li>▪ EtherNet/IP tools, e.g. RSLinx (Rockwell Automation)</li> </ul>		
Device Level Ring (DLR)	No		
Fix Input			
RPI	5 ms to 10 s (factory setting: 20 ms)		
Exclusive Owner Multicast		Instance	Size [byte]
	Instance configuration:	0x68	398
	O → T configuration:	0x66	64
	T → O configuration:	0x64	44
Exclusive Owner Multicast		Instance	Size [byte]
	Instance configuration:	0x69	-
	O → T configuration:	0x66	64
	T → O configuration:	0x64	44
Input only Multicast		Instance	Size [byte]
	Instance configuration:	0x68	398
	O → T configuration:	0xC7	-
	T → O configuration:	0x64	44
Input only Multicast		Instance	Size [byte]
	Instance configuration:	0x69	-
	O → T configuration:	0xC7	-
	T → O configuration:	0x64	44
Input Assembly	<ul style="list-style-type: none"> <li>▪ Current device diagnostics</li> <li>▪ Mass flow</li> <li>▪ Volume flow</li> <li>▪ Corrected volume flow</li> <li>▪ Density</li> <li>▪ Reference density</li> <li>▪ Temperature</li> <li>▪ Totalizer 1</li> <li>▪ Totalizer 2</li> <li>▪ Totalizer 3</li> </ul>		
Configurable Input			
RPI	5 ms to 10 s (factory setting: 20 ms)		
Exclusive Owner Multicast		Instance	Size [byte]
	Instance configuration:	0x68	398
	O → T configuration:	0x66	64
	T → O configuration:	0x65	88
Exclusive Owner Multicast		Instance	Size [byte]
	Instance configuration:	0x69	-



	O → T configuration:	0x66	64
	T → O configuration:	0x65	88
Input only Multicast		Instance	Size [byte]
	Instance configuration:	0x68	398
	O → T configuration:	0xC7	-
	T → O configuration:	0x65	88
Input only Multicast		Instance	Size [byte]
	Instance configuration:	0x69	-
	O → T configuration:	0xC7	-
	T → O configuration:	0x65	88
Configurable Input Assembly	<ul style="list-style-type: none"> <li>■ Current device diagnostics</li> <li>■ Mass flow</li> <li>■ Volume flow</li> <li>■ Corrected volume flow</li> <li>■ Density</li> <li>■ Reference density</li> <li>■ Temperature</li> <li>■ Totalizer 1</li> <li>■ Totalizer 2</li> <li>■ Totalizer 3</li> </ul> <p> The range of options increases if the measuring device has one or more application packages.</p>		
Fix Output			
Output Assembly	<ul style="list-style-type: none"> <li>■ Activation of reset totalizers 1-3</li> <li>■ Activation of pressure compensation</li> <li>■ Activation of reference density compensation</li> <li>■ Activation of temperature compensation</li> <li>■ Reset totalizers 1-3</li> <li>■ External pressure value</li> <li>■ Pressure unit</li> <li>■ External reference density</li> <li>■ Reference density unit</li> <li>■ External temperature</li> <li>■ Temperature unit</li> </ul>		
Configuration			
Configuration Assembly	<p>Only the most common configurations are listed below.</p> <ul style="list-style-type: none"> <li>■ Software write protection</li> <li>■ Mass flow unit</li> <li>■ Mass unit</li> <li>■ Volume flow unit</li> <li>■ Volume unit</li> <li>■ Corrected volume flow unit</li> <li>■ Corrected volume unit</li> <li>■ Density unit</li> <li>■ Reference density unit</li> <li>■ Temperature unit</li> <li>■ Pressure unit</li> <li>■ Length</li> <li>■ Totalizer 1-3: <ul style="list-style-type: none"> <li>- Assignment</li> <li>- Unit</li> <li>- Measuring mode</li> <li>- Failure mode</li> </ul> </li> <li>■ Alarm delay</li> </ul>		

## Power supply

### Terminal assignment

### Overview: housing version

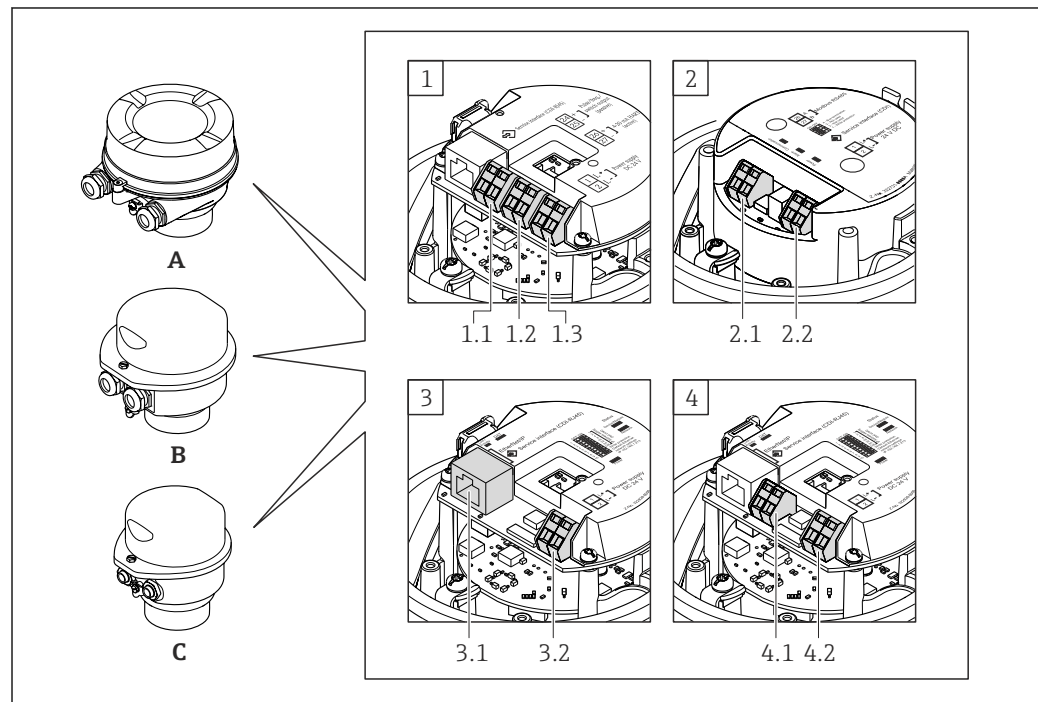

A0016770

- A Housing version: compact, aluminum coated
- B Housing version: compact, hygienic, stainless
- C Housing version: ultra compact, hygienic, stainless, M12 device plug
- 1 Connection version: 4-20 mA HART, pulse/frequency/switch output
  - 1.1 Signal transmission: pulse/frequency/switch output
  - 1.2 Signal transmission: 4-20 mA HART
  - 1.3 Supply voltage
- 2 Connection version: Modbus RS485
  - 2.1 Signal transmission
  - 2.2 Supply voltage
- 3 Connection version: EtherNet/IP
  - 3.1 Signal transmission
  - 3.2 Supply voltage
- 4 Connection version: PROFIBUS DP
  - 4.1 PROFIBUS DP
  - 4.2 Supply voltage

### Transmitter

Connection version 4-20 mA HART with pulse/frequency/switch output

Order code for "Output", option **B**

Depending on the housing version, the transmitters can be ordered with terminals or device plugs.

Order code for "Housing"	Connection methods available		Possible options for order code "Electrical connection"
	Outputs	Power supply	
Options A, B	Terminals	Terminals	<ul style="list-style-type: none"> <li>▪ Option A: coupling M20x1</li> <li>▪ Option B: thread M20x1</li> <li>▪ Option C: thread G ½"</li> <li>▪ Option D: thread NPT ½"</li> </ul>
Options A, B	Device plug	Terminals	<ul style="list-style-type: none"> <li>▪ Option L: plug M12x1 + thread NPT ½"</li> <li>▪ Option N: plug M12x1 + coupling M20</li> <li>▪ Option P: plug M12x1 + thread G ½"</li> <li>▪ Option U: plug M12x1 + thread M20</li> </ul>
Options A, B, C	Device plug	Device plug	Option Q: 2 x plug M12x1

Order code for "Housing":

- Option A: compact, coated aluminum
- Option B: compact, hygienic, stainless
- Option C: ultra compact, hygienic, stainless, M12 device plug

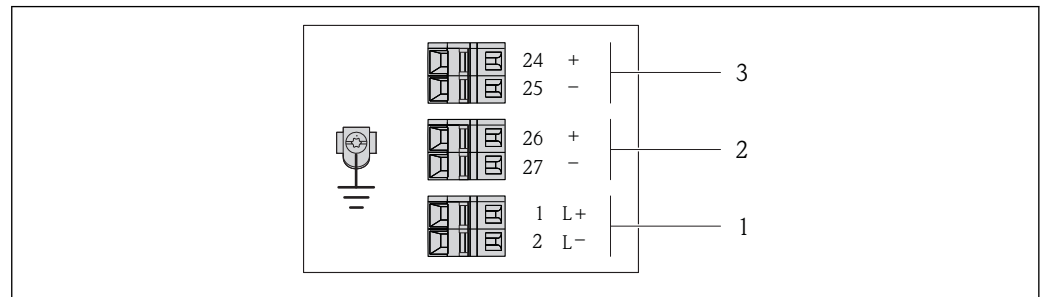

A0016888

2 Terminal assignment 4-20 mA HART with pulse/frequency/switch output

- 1 Power supply: DC 24 V
- 2 Output 1: 4-20 mA HART (active)
- 3 Output 2: pulse/frequency/switch output (passive)

Order code for "Output"	Terminal number					
	Power supply		Output 1		Output 2	
	2 (L-)	1 (L+)	27 (-)	26 (+)	25 (-)	24 (+)
Option B	DC 24 V		4-20 mA HART (active)		Pulse/frequency/switch output (passive)	

Order code for "Output":

Option B: 4-20 mA HART with pulse/frequency/switch output

*PROFIBUS DP connection version*

 For use in the non-hazardous area and Zone 2/Div. 2.

Order code for "Output", option **L**

Depending on the housing version, the transmitters can be ordered with terminals or device plugs.

Order code for "Housing"	Connection methods available		Possible options for order code "Electrical connection"
	Output	Power supply	
Options A, B	Terminals	Terminals	<ul style="list-style-type: none"> <li>▪ Option A: coupling M20x1</li> <li>▪ Option B: thread M20x1</li> <li>▪ Option C: thread G ½"</li> <li>▪ Option D: thread NPT ½"</li> </ul>
Options A, B	Device plug	Terminals	<ul style="list-style-type: none"> <li>▪ Option L: plug M12x1 + thread NPT ½"</li> <li>▪ Option N: plug M12x1 + coupling M20</li> <li>▪ Option P: plug M12x1 + thread G ½"</li> <li>▪ Option U: plug M12x1 + thread M20</li> </ul>
Options A, B, C	Device plug	Device plug	Option Q: 2 x plug M12x1

Order code for "Housing":

- Option A: compact, coated aluminum
- Option A: compact, hygienic, stainless
- Option C: ultra compact, hygienic, stainless, M12 device plug

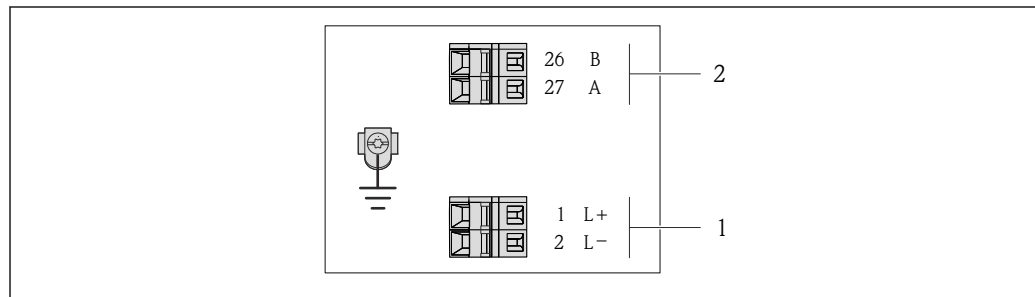

A0022716

 3 PROFIBUS DP terminal assignment

- 1 Power supply: DC 24 V
- 2 PROFIBUS DP

Order code for "Output"	Terminal number			
	Power supply		Output	
	2 (L-)	1 (L+)	26 (Rx/D/TxD-P)	27 (Rx/D/TxD-N)
Option L	DC 24 V		B	A

Order code for "Output":  
Option L: PROFIBUS DP, for use in non-hazardous areas and Zone 2/div. 2

Modbus RS485 connection version

 For use in the non-hazardous area and Zone 2/Div. 2.

Order code for "Output", option **M**

Depending on the housing version, the transmitters can be ordered with terminals or device plugs.

Order code for "Housing"	Connection methods available		Possible options for order code "Electrical connection"
	Output	Power supply	
Options A, B	Terminals	Terminals	<ul style="list-style-type: none"> <li>▪ Option A: coupling M20x1</li> <li>▪ Option B: thread M20x1</li> <li>▪ Option C: thread G ½"</li> <li>▪ Option D: thread NPT ½"</li> </ul>
Options A, B	Device plug	Terminals	<ul style="list-style-type: none"> <li>▪ Option L: plug M12x1 + thread NPT ½"</li> <li>▪ Option N: plug M12x1 + coupling M20</li> <li>▪ Option P: plug M12x1 + thread G ½"</li> <li>▪ Option U: plug M12x1 + thread M20</li> </ul>
Options A, B, C	Device plug	Device plug	Option Q: 2 x plug M12x1

Order code for "Housing":

- Option A: compact, coated aluminum
- Option B: compact, hygienic, stainless
- Option C: ultra compact, hygienic, stainless, M12 device plug
- Option C: ultra compact, stainless, M12 device plug

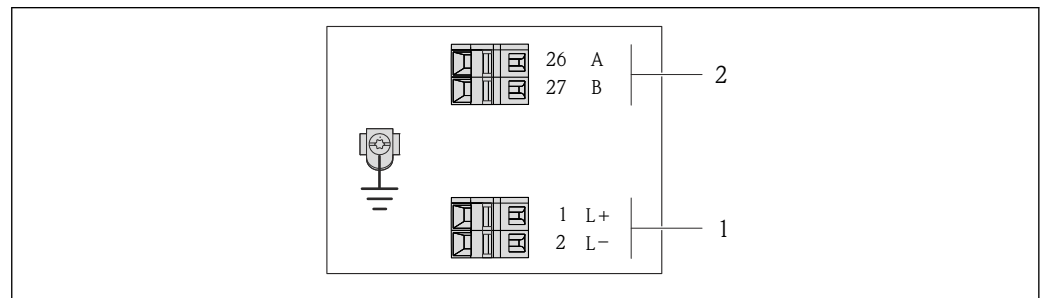

A0019528

 4 Modbus RS485 terminal assignment, connection version for use in non-hazardous areas and Zone 2/Div. 2

- 1 Power supply: DC 24 V
- 2 Modbus RS485

Order code for "Output"	Terminal number			
	Power supply		Output	
	2 (L-)	1 (L+)	27 (B)	26 (A)
Option <b>M</b>	DC 24 V		Modbus RS485	

Order code for "Output":  
Option **M**: Modbus RS485, for use in non-hazardous areas and Zone 2/Div. 2

Modbus RS485 connection version

 For use in the intrinsically safe area. Connection via Safety Barrier Promass 100.

Order code for "Output", option **M**

Depending on the housing version, the transmitters can be ordered with terminals or device plugs.

Order code for "Housing"	Connection methods available		Possible options for order code "Electrical connection"
	Output	Power supply	
Options A, B	Terminals	Terminals	<ul style="list-style-type: none"> <li>■ Option A: coupling M20x1</li> <li>■ Option B: thread M20x1</li> <li>■ Option C: thread G ½"</li> <li>■ Option D: thread NPT ½"</li> </ul>
A, B, C	Device plug		Option I: plug M12x1
Order code for "Housing": <ul style="list-style-type: none"> <li>■ Option A: compact, coated aluminum</li> <li>■ Option B: compact, hygienic, stainless</li> <li>■ Option C: ultra compact, hygienic, stainless, M12 device plug</li> </ul>			

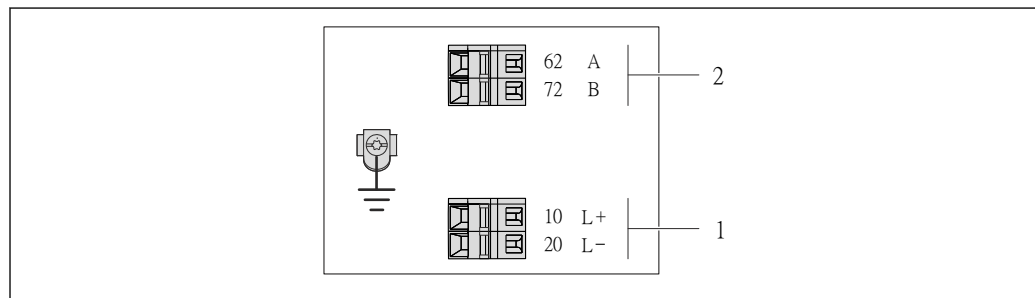

A0017053

 5 Modbus RS485 terminal assignment, connection version for use in intrinsically safe areas (connection via Safety Barrier Promass 100)

- 1 Intrinsically safe power supply
- 2 Modbus RS485

Order code for "Output"	20 (L-)	10 (L+)	72 (B)	62 (A)
Option <b>M</b>	Intrinsically safe supply voltage		Modbus RS485 intrinsically safe	
Order code for "Output": Option <b>M</b> : Modbus RS485, for use in intrinsically safe areas (connection via Safety Barrier Promass 100)				

*EtherNet/IP connection version*

Order code for "Output", option **N**

Depending on the housing version, the transmitters can be ordered with terminals or device plugs.

Order code for "Housing"	Connection methods available		Possible options for order code "Electrical connection"
	Output	Power supply	
Options <b>A, B</b>	Device plug	Terminals	<ul style="list-style-type: none"> <li>▪ Option <b>L</b>: plug M12x1 + thread NPT 1/2"</li> <li>▪ Option <b>N</b>: plug M12x1 + coupling M20</li> <li>▪ Option <b>P</b>: plug M12x1 + thread G 1/2"</li> <li>▪ Option <b>U</b>: plug M12x1 + thread M20</li> </ul>
Options <b>A, B, C</b>	Device plug	Device plug	Option <b>Q</b> : 2 x plug M12x1

Order code for "Housing":

- Option **A**: compact, coated aluminum
- Option **B**: compact, hygienic, stainless
- Option **C**: ultra compact, hygienic, stainless, M12 device plug

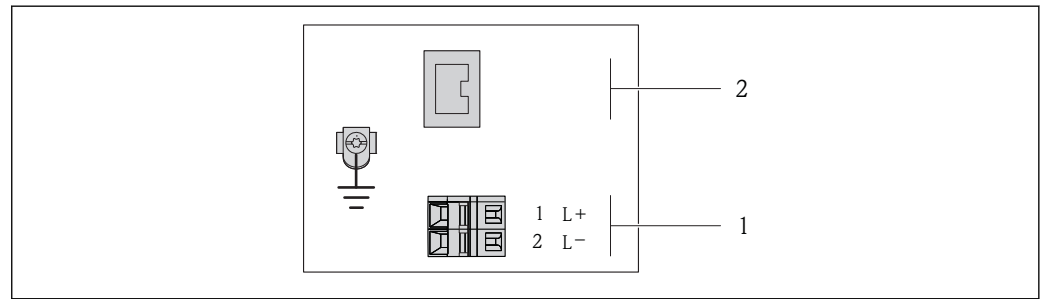

A0017054

6 EtherNet/IP terminal assignment

- 1 Power supply: DC 24 V
- 2 EtherNet/IP

Order code for "Output"	Terminal number		Output Device plug M12x1
	Power supply 2 (L-)	1 (L+)	
Option <b>N</b>	DC 24 V		EtherNet/IP

Order code for "Output":  
Option **N**: EtherNet/IP

Safety Barrier Promass 100

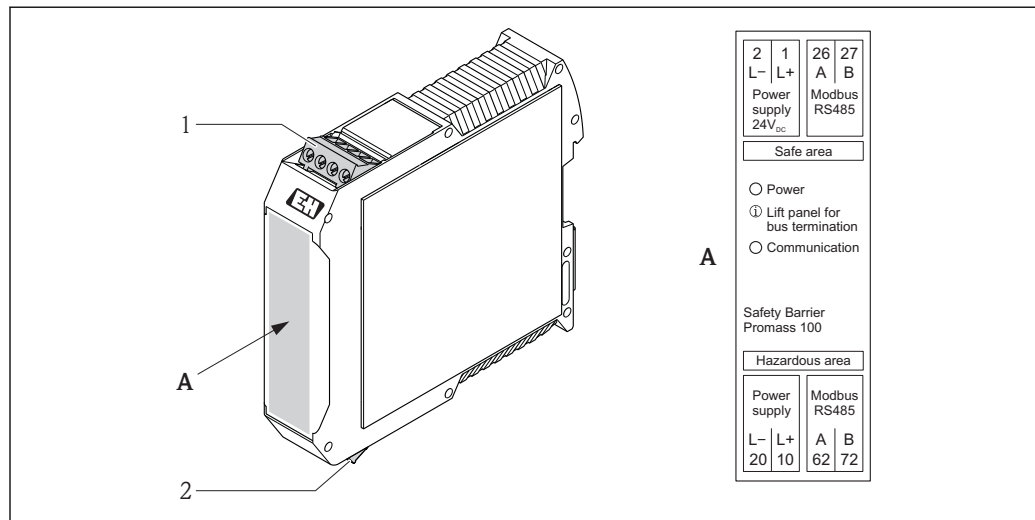

7 Safety Barrier Promass 100 with terminals

- 1 Non-hazardous area and Zone 2/Div. 2
- 2 Intrinsically safe area

Pin assignment, device plug

- i** Order codes for the M12x1 connectors, see the "Order code for **electrical connection**" column:
  - 4-20 mA HART, pulse/frequency/switch output (→ 18)
  - PROFIBUS-DP (→ 20)
  - Modbus RS485 (→ 21)
  - EtherNet/IP (→ 23)

Supply voltage

For all connection versions except MODBUS RS485 intrinsically safe (device side)

- i** Device plug MODBUS RS485 intrinsically safe with supply voltage (→ 25)

	Pin	Assignment	Coding	Plug/socket
	1	L+	DC 24 V	A
2				
3				
4	L-	DC 24 V		
5		Grounding/shielding		



- i** The following is recommended as a socket:
  - Binder, series 763, part no. 79 3440 35 05
  - Alternatively: Phoenix part no. 1669767 SAC-5P-M12MS
    - With the order code for "Output", option **B**: 4-20 mA HART, pulse/frequency/switch output
    - With the order code for "Output", option **N**: EtherNet/IP
  - When using the device in a hazardous location: Use a suitably certified socket.

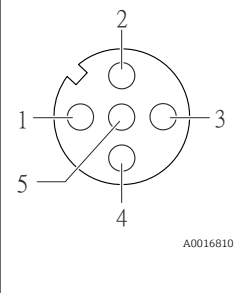

### 4-20 mA HART with pulse/frequency/switch output

Device plug for signal transmission (device side)

	Pin		Assignment	Coding	Plug/socket
	1	+	4-20 mA HART (active)	A	Socket
	2	-	4-20 mA HART (active)		
	3	+	Pulse/frequency/switch output (passive)		
	4	-	Pulse/frequency/switch output (passive)		
	5		Grounding/shielding		

-  Recommended plug: Binder, series 763, part no. 79 3439 12 05
-  When using the device in a hazardous location: Use a suitably certified plug.

### PROFIBUS DP

-  For use in the non-hazardous area and Zone 2/Div. 2.

Device plug for signal transmission (device side)

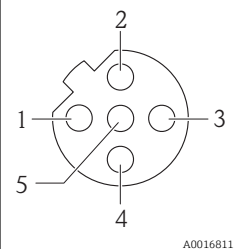

	Pin		Assignment	Coding	Plug/socket
	1			B	Socket
	2	A	PROFIBUS DP		
	3				
	4	B	PROFIBUS DP		
	5		Grounding/shielding		

-  Recommended plug: Binder, series 763, part no. 79 4449 20 05
-  When using the device in a hazardous location: Use a suitably certified plug.

### MODBUS RS485

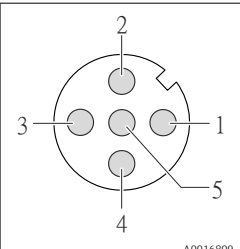
Device plug for signal transmission with supply voltage (device side), MODBUS RS485 (intrinsically safe)

	Pin		Assignment	Coding	Plug/socket
	1	L+	Supply voltage, intrinsically safe	A	Plug
	2	A	Modbus RS485 intrinsically safe		
	3	B			
	4	L-	Supply voltage, intrinsically safe		
	5		Grounding/shielding		

-  Recommended socket: Binder, series 763, part no. 79 3439 12 05
-  When using the device in a hazardous location: Use a suitably certified socket.

Device plug for signal transmission (device side), MODBUS RS485 (not intrinsically safe)

**i** For use in the non-hazardous area and Zone 2/Div. 2.

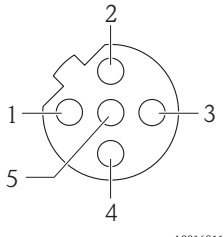
 <p style="text-align: center; font-size: small;">A0016811</p>	Pin	Assignment		Coding	Plug/socket
	1			B	Socket
	2	A	Modbus RS485		
	3				
	4	B	Modbus RS485		
5		Grounding/shielding			

- i** Recommended plug: Binder, series 763, part no. 79 4449 20 05
- When using the device in a hazardous location: Use a suitably certified plug.

### EtherNet/IP

Device plug for signal transmission (device side)

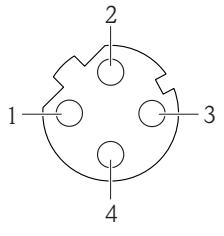
 <p style="text-align: center; font-size: small;">A0016812</p>	Pin	Assignment		Coding	Plug/socket
	1	+	Tx	D	Socket
	2	+	Rx		
	3	-	Tx		
	4	-	Rx		

- i** Recommended plug:
  - Binder, series 763, part no. 99 3729 810 04
  - Phoenix, part no. 1543223 SACC-M12MSD-4Q
  - When using the device in a hazardous location: Use a suitably certified plug.

### Supply voltage

#### Transmitter

- For device version with all communication types except Modbus RS485 intrinsically safe: DC 20 to 30 V
- For device version with Modbus RS485 intrinsically safe: power supply via Safety Barrier Promass 100

The power unit must be tested to ensure it meets safety requirements (e.g. PELV, SELV).

#### Safety Barrier Promass 100

DC 20 to 30 V

### Power consumption

#### Transmitter

Order code for "Output"	Maximum Power consumption
Option <b>B</b> : 4-20mA HART, pulse/frequency/switch output	3.5 W
Option <b>L</b> : PROFIBUS DP	3.5 W
Option <b>M</b> : Modbus RS485, for use in non-hazardous areas and Zone 2/Div. 2	3.5 W
Option <b>M</b> : Modbus RS485, for use in intrinsically safe areas	2.45 W
Option <b>N</b> : EtherNet/IP	3.5 W

Safety Barrier Promass 100

Order code for "Output"	Maximum Power consumption
Option <b>M</b> : Modbus RS485, for use in intrinsically safe areas	4.8 W

Current consumption

Transmitter

Order code for "Output"	Maximum Current consumption	Maximum switch-on current
Option <b>B</b> : 4-20mA HART, pul./freq./switch output	145 mA	18 A (<0.125 ms)
Option <b>L</b> : PROFIBUS DP	145 mA	18 A (<0.125 ms)
Option <b>M</b> : Modbus RS485, for use in non-hazardous areas and Zone 2/Div. 2	90 mA	10 A (<0.8 ms)
Option <b>M</b> : Modbus RS485, for use in intrinsically safe areas	145 mA	16 A (<0.4 ms)
Option <b>N</b> : EtherNet/IP	145 mA	18 A (<0.125 ms)

Safety Barrier Promass 100

Order code for "Output"	Maximum Current consumption	Maximum switch-on current
Option <b>M</b> : Modbus RS485, for use in intrinsically safe areas	230 mA	10 A (<0.8 ms)

Power supply failure

- Totalizers stop at the last value measured.
- Depending on the device version, the configuration is retained in the device memory or in the plug-in memory (HistoROM DAT).
- Error messages (incl. total operated hours) are stored.

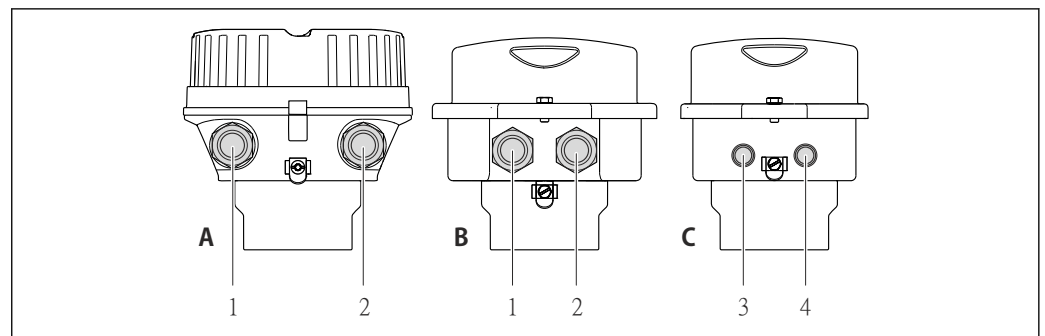

Electrical connection

Connecting the transmitter



A0016924

- A Housing version: compact, aluminum coated
- B Housing version: compact hygienic, stainless
- 1 Cable entry or device plug for signal transmission
- 2 Cable entry or device plug for supply voltage
- C Housing version: ultra-compact hygienic, stainless, M12 device plug
- 3 Device plug for signal transmission
- 4 Device plug for supply voltage

-  ■ Terminal assignment (→  18)
- Pin assignment, device plug (→  24)

-  In the case of device versions with a connector, the transmitter housing does not need to be opened to connect the signal cable or power supply cable.

## Connection examples

### Current output 4-20 mA HART

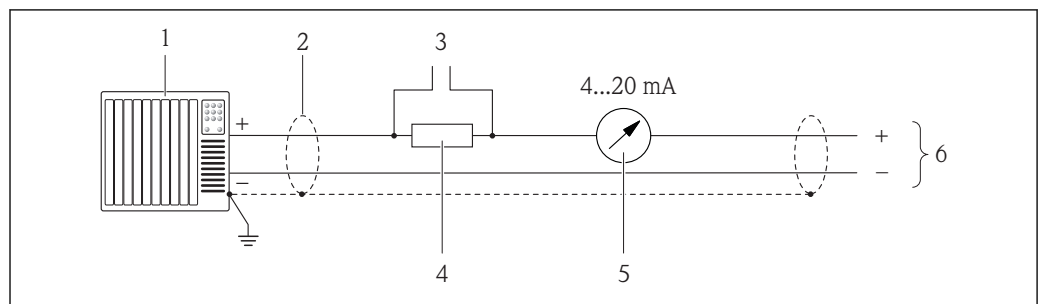

**8** Connection example for 4-20 mA HART current output (active)

- 1 Automation system with current input (e.g. PLC)
- 2 Cable shield, observe cable specifications (→ 32)
- 3 Connection for HART operating devices (→ 68)
- 4 Resistor for HART communication ( $\geq 250 \Omega$ ): observe maximum load (→ 9)
- 5 Analog display unit: observe maximum load (→ 9)
- 6 Transmitter

### Pulse/frequency output

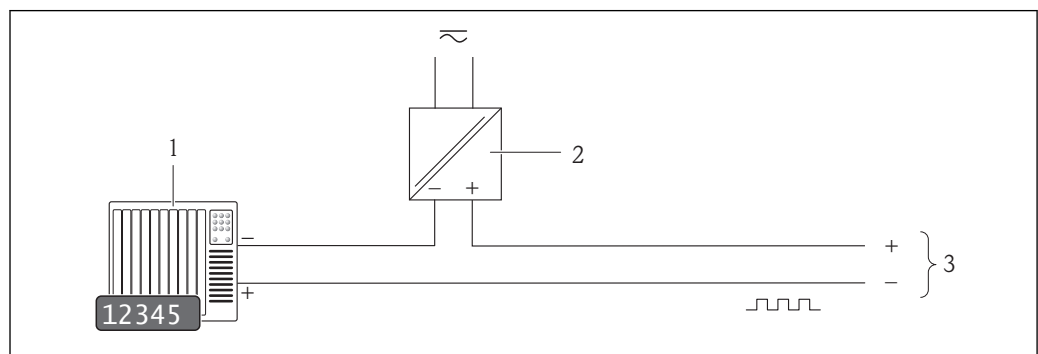

**9** Connection example for pulse/frequency output (passive)

- 1 Automation system with pulse/frequency input (e.g. PLC)
- 2 Power supply
- 3 Transmitter: observe input values (→ 9)

### Switch output

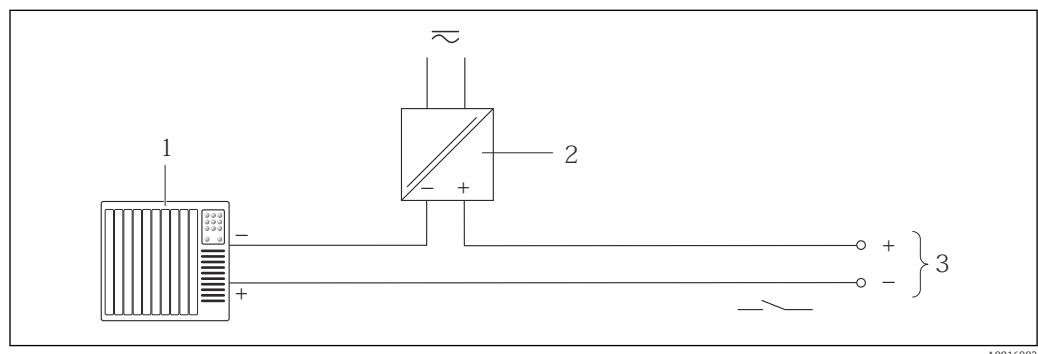

**10** Connection example for switch output (passive)

- 1 Automation system with switch input (e.g. PLC)
- 2 Power supply
- 3 Transmitter: observe input values (→ 9)

PROFIBUS DP

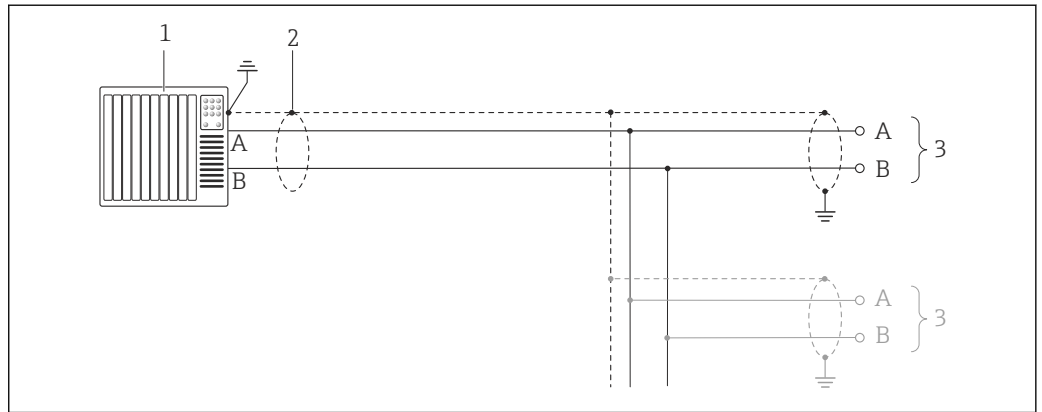

A0021429

11 Connection example for PROFIBUS DP, non-hazardous area and Zone 2/Div. 2

- 1 Control system (e.g. PLC)
- 2 Cable shield: the cable shield must be grounded at both ends to comply with EMC requirements; observe cable specifications (→ 32)
- 3 Distribution box
- 4 Transmitter

**i** If baud rates > 1.5 MBaud an EMC cable entry must be used and the cable shield must continue as far as the terminal wherever possible.

Modbus RS485

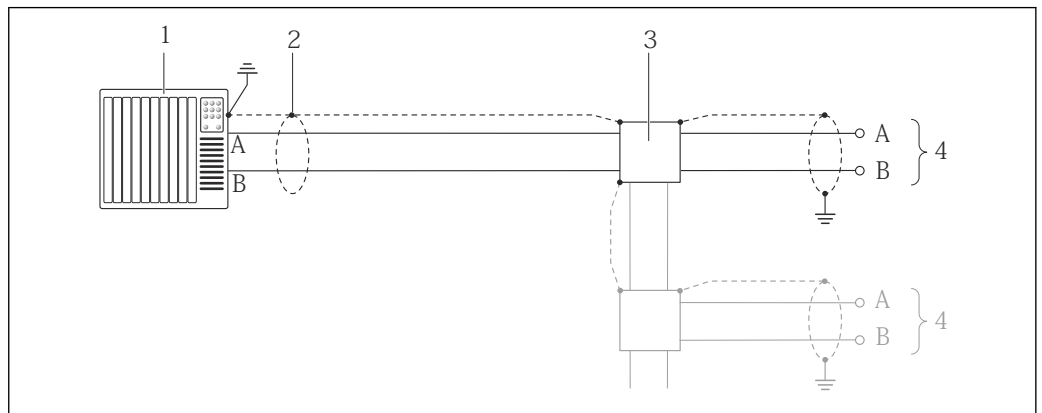

A0016803

12 Connection example for Modbus RS485, non-hazardous area and Zone 2/Div. 2

- 1 Control system (e.g. PLC)
- 2 Cable shield: the cable shield must be grounded at both ends to comply with EMC requirements; observe cable specifications (→ 32)
- 3 Distribution box
- 4 Transmitter

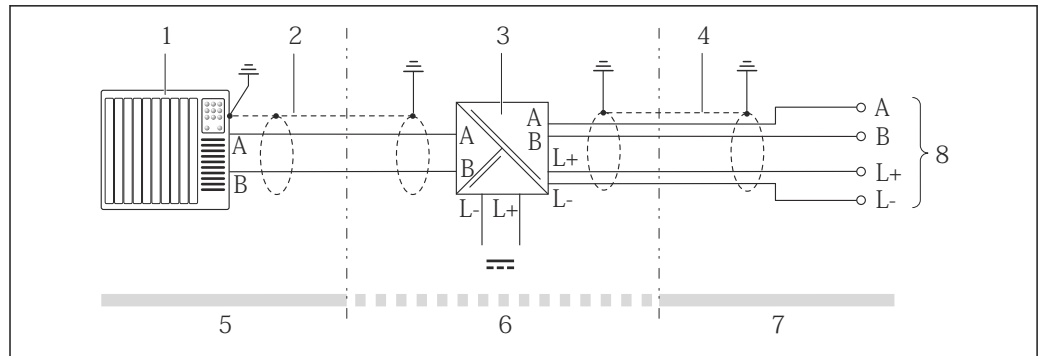

A0016804

13 Connection example for Modbus RS485 intrinsically safe

- 1 Control system (e.g. PLC)
- 2 Cable shield, observe cable specifications (→ 32)
- 3 Safety Barrier Promass 100
- 4 Observe cable specifications (→ 32)
- 5 Non-hazardous area
- 6 Non-hazardous area and Zone 2/Div. 2
- 7 Intrinsically safe area
- 8 Transmitter

#### EtherNet/IP

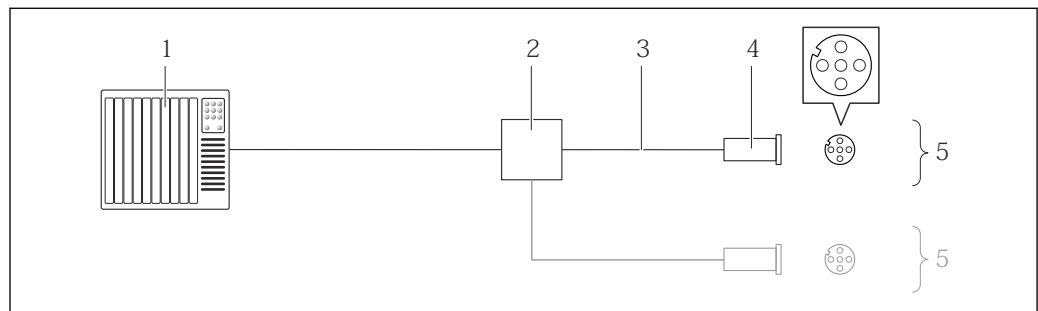

A0016805

14 Connection example for EtherNet/IP

- 1 Control system (e.g. PLC)
- 2 Ethernet switch
- 3 Observe cable specifications (→ 32)
- 4 Connector
- 5 Transmitter

HART input

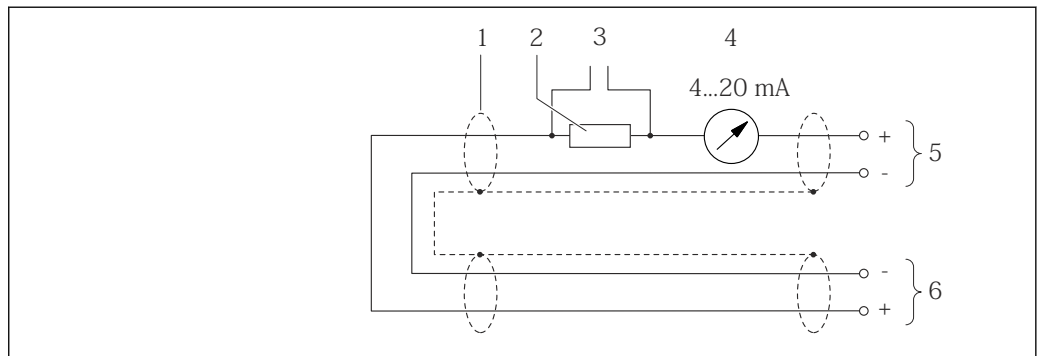

15 Connection example for HART input (burst mode) via current output (active)

- 1 Cable shield, observe cable specifications (→ 32)
- 2 Resistor for HART communication ( $\geq 250 \Omega$ ): observe maximum load (→ 9)
- 3 Connection for HART operating devices (→ 68)
- 4 Analog display unit
- 5 Transmitter
- 6 Sensor for external measured variable

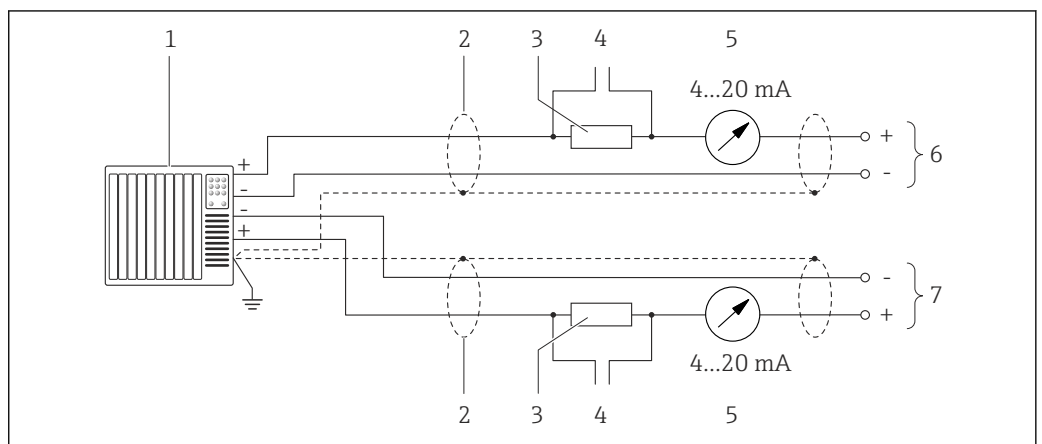

16 Connection example for HART input (master mode) via current output (active)

- 1 Automation system with current input (e.g. PLC).  
Prerequisite: automation system with HART version 6, HART commands 113 and 114 can be processed.
- 2 Cable shield, observe cable specifications (→ 32)
- 3 Resistor for HART communication ( $\geq 250 \Omega$ ): observe maximum load (→ 9)
- 4 Connection for HART operating devices (→ 68)
- 5 Analog display unit
- 6 Transmitter
- 7 Sensor for external measured variable

Potential equalization

No special measures for potential equalization are required.



For devices intended for use in hazardous locations, please observe the guidelines in the Ex documentation (XA).

Terminals

Transmitter

Spring terminals for wire cross-sections  $0.5$  to  $2.5 \text{ mm}^2$  (20 to 14 AWG)

Safety Barrier Promass 100

Plug-in screw terminals for wire cross-sections  $0.5$  to  $2.5 \text{ mm}^2$  (20 to 14 AWG)

**Cable entries**

- Cable gland: M20 × 1.5 with cable  $\phi$ 6 to 12 mm (0.24 to 0.47 in)
- Thread for cable entry:
  - NPT ½"
  - G ½"
  - M20

**Cable specification****Permitted temperature range**

- -40 °C (-40 °F) to +80 °C (+176 °F)
- Minimum requirement: cable temperature range  $\geq$  ambient temperature +20 K

**Power supply cable**

Standard installation cable is sufficient.

**Signal cable***Current output*

For 4-20 mA HART: Shielded cable recommended. Observe grounding concept of the plant.

*Pulse/frequency/switch output*

Standard installation cable is sufficient.

*PROFIBUS DP*

The IEC 61158 standard specifies two types of cable (A and B) for the bus line which can be used for every transmission rate. Cable type A is recommended.

<b>Cable type</b>	A
<b>Characteristic impedance</b>	135 to 165 $\Omega$ at a measuring frequency of 3 to 20 MHz
<b>Cable capacitance</b>	<30 pF/m
<b>Wire cross-section</b>	>0.34 mm <sup>2</sup> (22 AWG)
<b>Cable type</b>	Twisted pairs
<b>Loop resistance</b>	$\leq$ 110 $\Omega$ /km
<b>Signal damping</b>	Max. 9 dB over the entire length of the cable cross-section
<b>Shielding</b>	Copper braided shielding or braided shielding with foil shield. When grounding the cable shield, observe the grounding concept of the plant.

*Modbus RS485*

The EIA/TIA-485 standard specifies two types of cable (A and B) for the bus line which can be used for every transmission rate. Cable type A is recommended.

<b>Cable type</b>	A
<b>Characteristic impedance</b>	135 to 165 $\Omega$ at a measuring frequency of 3 to 20 MHz
<b>Cable capacitance</b>	<30 pF/m
<b>Wire cross-section</b>	>0.34 mm <sup>2</sup> (22 AWG)
<b>Cable type</b>	Twisted pairs
<b>Loop resistance</b>	$\leq$ 110 $\Omega$ /km
<b>Signal damping</b>	Max. 9 dB over the entire length of the cable cross-section
<b>Shielding</b>	Copper braided shielding or braided shielding with foil shield. When grounding the cable shield, observe the grounding concept of the plant.

*EtherNet/IP*

The standard ANSI/TIA/EIA-568-B.2 Annex specifies CAT 5 as the minimum category for a cable used for EtherNet/IP. CAT 5e and CAT 6 are recommended.



 For more information on planning and installing EtherNet/IP networks, please refer to the "Media Planning and Installation Manual. EtherNet/IP" of the ODVA Organization.

**Connecting cable between Safety Barrier Promass 100 and measuring device**

<b>Cable type</b>	Shielded twisted-pair cable with 2x2 wires. When grounding the cable shield, observe the grounding concept of the plant.
<b>Maximum cable resistance</b>	2,5 Ω, one side



► Comply with the maximum cable resistance specifications to ensure the operational reliability of the measuring device.

The maximum cable length for individual wire cross-sections is specified in the table below. Observe the maximum capacitance and inductance per unit length of the cable and connection values for hazardous areas (→  12).

Wire cross-section		Maximum cable length	
[mm <sup>2</sup> ]	[AWG]	[m]	[ft]
0.5	20	70	230
0.75	18	100	328
1.0	17	100	328
1.5	16	200	656
2.5	14	300	984

**Performance characteristics**

**Reference operating conditions**

- Error limits based on ISO 11631
  - Water with +15 to +45 °C (+59 to +113 °F) at 2 to 6 bar (29 to 87 psi)
  - Specifications as per calibration protocol
  - Accuracy based on accredited calibration rigs that are traced to ISO 17025.
-  To obtain measured errors, use the *Applicator* sizing tool (→  75)

**Maximum measured error**

o.r. = of reading; 1 g/cm<sup>3</sup> = 1 kg/l; T = medium temperature



**Base accuracy**

**Mass flow and volume flow (liquids)**

±0.15 % o.r.

**Mass flow (gases)**

±0.75 % o.r.

 Design fundamentals (→  36)

**Density (liquids)**

- Reference conditions: ±0.0005 g/cm<sup>3</sup>
- Standard density calibration: ±0.02 g/cm<sup>3</sup>  
(valid over the entire temperature range and density range)

**Temperature**

±0.5 °C ± 0.005 · T °C (±0.9 °F ± 0.003 · (T - 32) °F)

**Zero point stability**

DN		Zero point stability	
[mm]	[in]	[kg/h]	[lb/min]
8	$\frac{3}{8}$	0.20	0.007
15	$\frac{1}{2}$	0.65	0.024
25	1	1.80	0.066
40	$1\frac{1}{2}$	4.50	0.165
50	2	7.0	0.257
80	3	18.0	0.6615

**Flow values**

Flow values as turndown parameter depending on nominal diameter.

*SI units*

DN [mm]	1:1	1:10	1:20	1:50	1:100	1:500
	[kg/h]	[kg/h]	[kg/h]	[kg/h]	[kg/h]	[kg/h]
8	2 000	200	100	40	20	4
15	6 500	650	325	130	65	13
25	18 000	1 800	900	360	180	36
40	45 000	4 500	2 250	900	450	90
50	70 000	7 000	3 500	1 400	700	140
80	180 000	18 000	9 000	3 600	1 800	360

*US units*

DN [inch]	1:1	1:10	1:20	1:50	1:100	1:500
	[lb/min]	[lb/min]	[lb/min]	[lb/min]	[lb/min]	[lb/min]
$\frac{3}{8}$	73.50	7.350	3.675	1.470	0.735	0.147
$\frac{1}{2}$	238.9	23.89	11.95	4.778	2.389	0.478
1	661.5	66.15	33.08	13.23	6.615	1.323
$1\frac{1}{2}$	1 654	165.4	82.70	33.08	16.54	3.308
2	2 573	257.3	128.7	51.46	25.73	5.146
3	6 615	661.5	330.8	132.3	66.15	13.23

**Accuracy of outputs**

o.r. = of reading; o.f.s. = of full scale value

 The output accuracy must be factored into the measured error if analog outputs are used, but can be ignored for fieldbus outputs (e.g. Modbus RS485, EtherNet/IP).

*Current output*

<b>Accuracy</b>	Max. $\pm 0.05$ % o.f.s. or $\pm 5$ $\mu$ A
-----------------	---

*Pulse/frequency output*

<b>Accuracy</b>	Max. $\pm 50$ ppm o.r.
-----------------	------------------------

**Repeatability**

o.r. = of reading;  $1 \text{ g/cm}^3 = 1 \text{ kg/l}$ ; T = medium temperature

**Base repeatability**

**Mass flow and volume flow (liquids)**

$\pm 0.075 \%$  o.r.

**Mass flow (gases)**

$\pm 0.35 \%$  o.r.

 Design fundamentals ( $\rightarrow$   36)

**Density (liquids)**

$\pm 0.00025 \text{ g/cm}^3$

**Temperature**

$\pm 0.25 \text{ }^\circ\text{C} \pm 0.0025 \cdot T \text{ }^\circ\text{C}$  ( $\pm 0.45 \text{ }^\circ\text{F} \pm 0.0015 \cdot (T - 32) \text{ }^\circ\text{F}$ )

**Response time**

The response time depends on the configuration (damping).

**Influence of ambient temperature**

o.r. = of reading; o.f.s. = of full scale value

**Current output**

<b>Temperature coefficient</b>	Max. $\pm 50 \text{ ppm/}^\circ\text{C}$ o.f.s. or $\pm 1 \text{ } \mu\text{A/}^\circ\text{C}$
--------------------------------	--

**Pulse/frequency output**

<b>Temperature coefficient</b>	Max. $\pm 50 \text{ ppm o.r. / } 100 \text{ }^\circ\text{C}$
--------------------------------	--

**Influence of medium temperature**

**Mass flow and volume flow**

When there is a difference between the temperature for zero point adjustment and the process temperature, the typical measured error of the sensor is  $\pm 0.0002 \%$  of the full scale value/ $^\circ\text{C}$  ( $\pm 0.0001 \%$  of the full scale value/ $^\circ\text{F}$ ).

**Density**

When there is a difference between the density calibration temperature and the process temperature, the typical measured error of the sensor is  $\pm 0.0001 \text{ g/cm}^3 / ^\circ\text{C}$  ( $\pm 0.00005 \text{ g/cm}^3 / ^\circ\text{F}$ ). Field density calibration is possible.

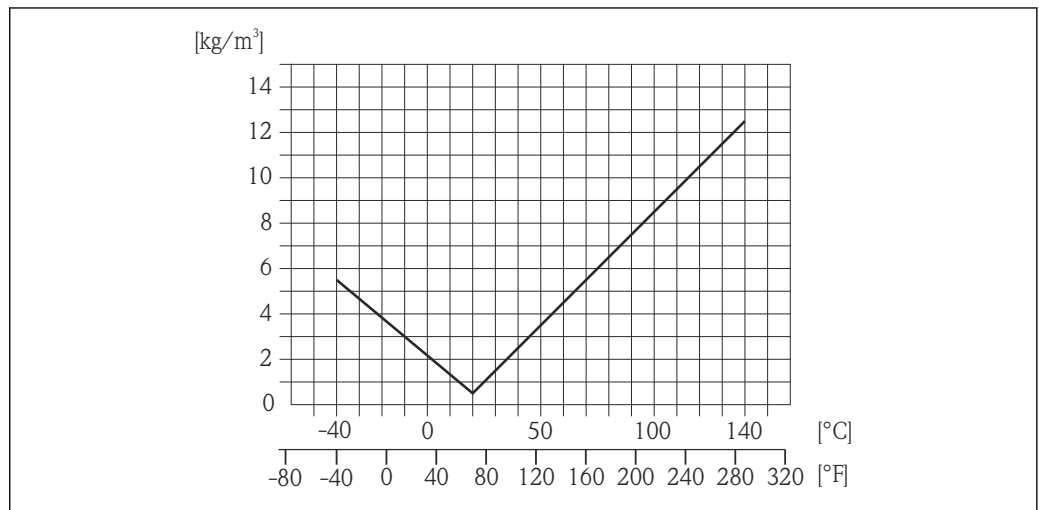

 17 Field density calibration, for example at  $+20 \text{ }^\circ\text{C}$  ( $+68 \text{ }^\circ\text{F}$ )

**Temperature**

$\pm 0.005 \cdot T \text{ }^\circ\text{C}$  ( $\pm 0.005 \cdot (T - 32) \text{ }^\circ\text{F}$ )

**Influence of medium pressure**

The table below shows the effect on accuracy of mass flow due to a difference between calibration pressure and process pressure.

o.r. = of reading

DN		[% o.r./bar]	[% o.r./psi]
[mm]	[in]		
8	3/8	no influence	
15	1/2	no influence	
25	1	no influence	
40	1 1/2	no influence	
50	2	-0.009	-0.0006
80	3	-0.020	-0.0014

**Design fundamentals**

o.r. = of reading, o.f.s. = of full scale value

BaseAccu = base accuracy in % o.r., BaseRepeat = base repeatability in % o.r.

MeasValue = measured value; ZeroPoint = zero point stability

*Calculation of the maximum measured error as a function of the flow rate*

Flow rate	Maximum measured error in % o.r.
$\geq \frac{\text{ZeroPoint}}{\text{BaseAccu}} \cdot 100$ <small>A0021332</small>	$\pm \text{BaseAccu}$ <small>A0021339</small>
$< \frac{\text{ZeroPoint}}{\text{BaseAccu}} \cdot 100$ <small>A0021333</small>	$\pm \frac{\text{ZeroPoint}}{\text{MeasValue}} \cdot 100$ <small>A0021334</small>

*Calculation of the maximum repeatability as a function of the flow rate*

Flow rate	Maximum repeatability in % o.r.
$\geq \frac{1/2 \cdot \text{ZeroPoint}}{\text{BaseRepeat}} \cdot 100$ <small>A0021335</small>	$\pm \text{BaseRepeat}$ <small>A0021340</small>
$< \frac{1/2 \cdot \text{ZeroPoint}}{\text{BaseRepeat}} \cdot 100$ <small>A0021336</small>	$\pm 1/2 \cdot \frac{\text{ZeroPoint}}{\text{MeasValue}} \cdot 100$ <small>A0021337</small>

**Example for max. measured error**

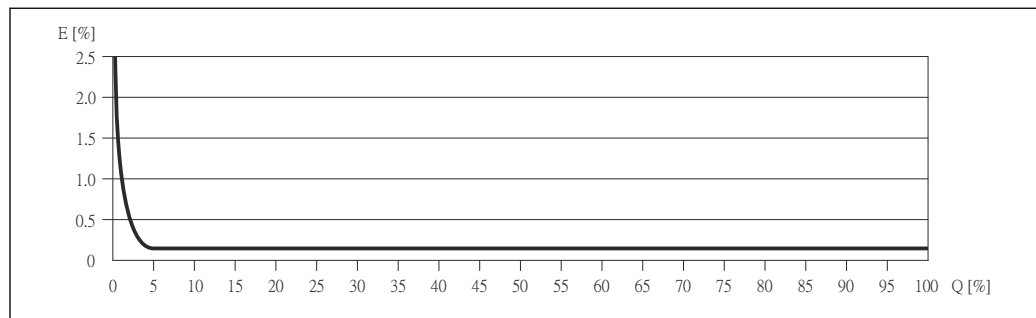

E Error: Maximum measured error as % o.r. (example)  
 Q Flow rate as %

## Installation

No special measures such as supports are necessary. External forces are absorbed by the construction of the device.

### Mounting location

To prevent measuring errors arising from accumulation of gas bubbles in the measuring tube, avoid the following mounting locations in the pipe:

- Highest point of a pipeline.
- Directly upstream of a free pipe outlet in a down pipe.

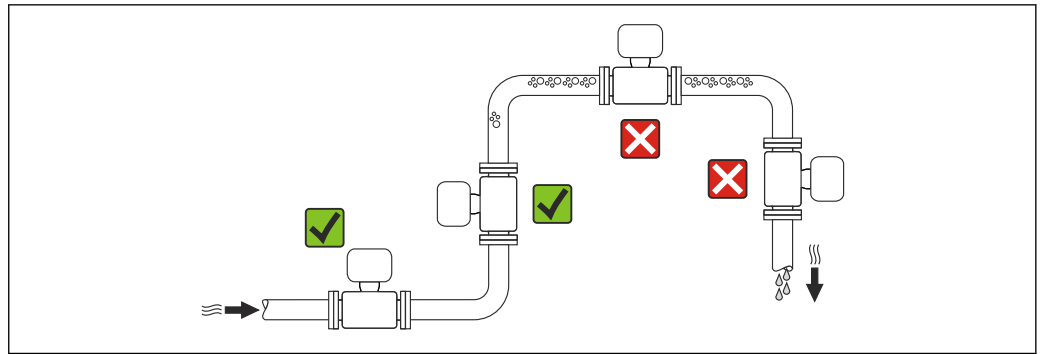

A0023944

### Installation in down pipes

However, the following installation suggestion allows for installation in an open vertical pipeline. Pipe restrictions or the use of an orifice with a smaller cross-section than the nominal diameter prevent the sensor running empty while measurement is in progress.

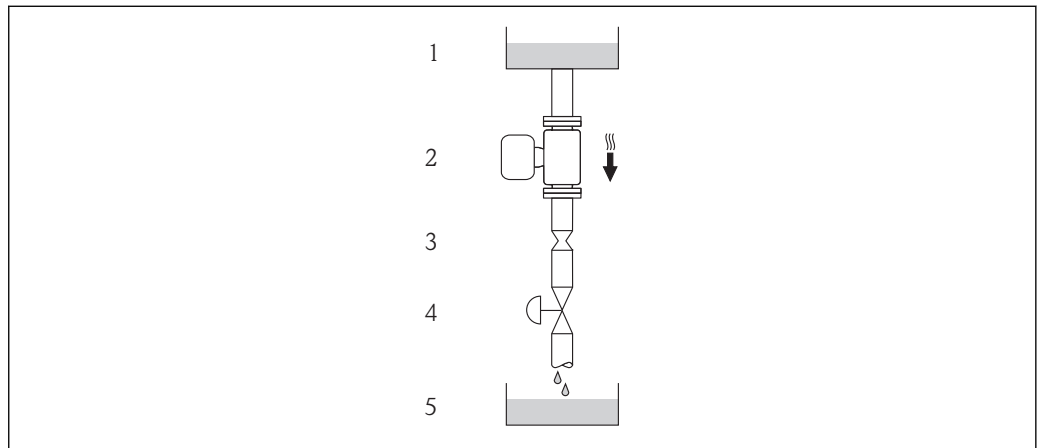

A0015596

18 Installation in a down pipe (e.g. for batching applications)

- 1 Supply tank
- 2 Sensor
- 3 Orifice plate, pipe restriction
- 4 Valve
- 5 Batching tank

DN		Ø orifice plate, pipe restriction	
[mm]	[in]	[mm]	[in]
8	3/8	6	0.24
15	1/2	10	0.40
25	1	14	0.55
40	1 1/2	22	0.87

DN		Ø orifice plate, pipe restriction	
[mm]	[in]	[mm]	[in]
50	2	28	1.10
80	3	50	1.97

## Orientation

The direction of the arrow on the sensor nameplate helps you to install the sensor according to the flow direction (direction of medium flow through the piping).

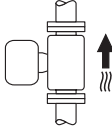
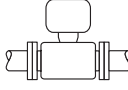
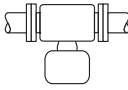
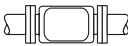
Orientation			Recommendation
A	Vertical orientation	 A0015591	☑☑
B	Horizontal orientation, transmitter head up	 A0015589	☑☑ <sup>1)</sup> Exception: (→ ☑ 19, ☑ 38)
C	Horizontal orientation, transmitter head down	 A0015590	☑☑ <sup>2)</sup> Exception: (→ ☑ 19, ☑ 38)
D	Horizontal orientation, transmitter head at side	 A0015592	☒

- 1) Applications with low process temperatures may reduce the ambient temperature. To maintain the minimum ambient temperature for the transmitter, this orientation is recommended.
- 2) Applications with high process temperatures may increase the ambient temperature. To maintain the maximum ambient temperature for the transmitter, this orientation is recommended.

If a sensor is installed horizontally with a curved measuring tube, match the position of the sensor to the fluid properties.

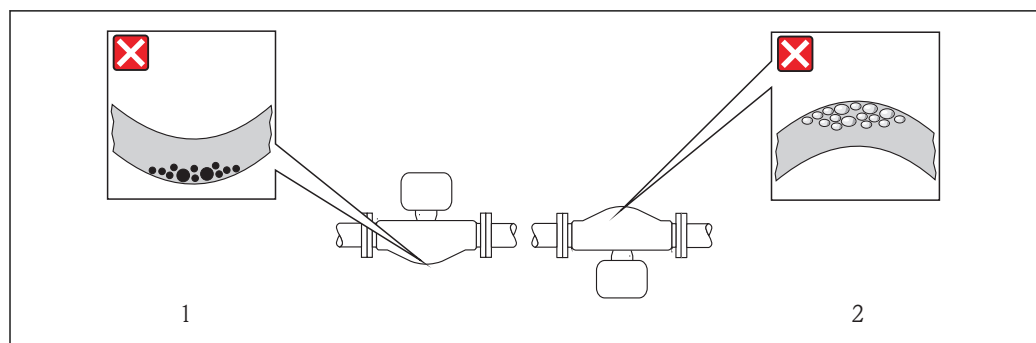

☑ 19 Orientation of sensor with curved measuring tube

- 1 Avoid this orientation for fluids with entrained solids: Risk of solids accumulating.
- 2 Avoid this orientation for outgassing fluids: Risk of gas accumulating.

## Inlet and outlet runs

No special precautions need to be taken for fittings which create turbulence, such as valves, elbows or T-pieces, as long as no cavitation occurs (→ ☑ 46).

## Special mounting instructions

### Rupture disk

Make sure that the function and operation of the rupture disk is not impeded through the installation of the device. The position of the rupture disk is indicated on a sticker applied over it. If the rupture disk is triggered, the sticker is destroyed. The disk can therefore be visually monitored. For additional information that is relevant to the process (→ ☑ 45).

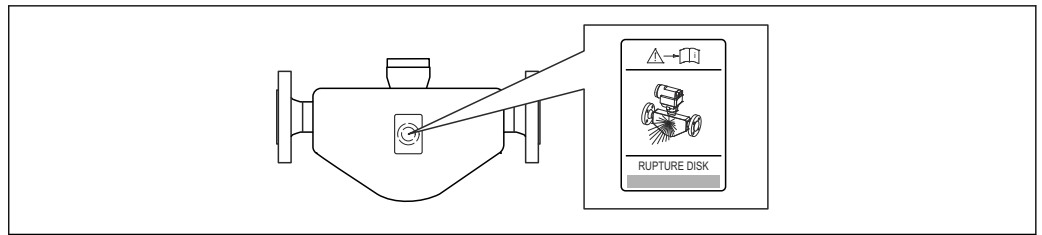

A0007823

20 Rupture disk label

### Zero point adjustment

All measuring devices are calibrated in accordance with state-of-the-art technology. Calibration takes place under reference conditions (→ 33). Therefore, a zero point adjustment in the field is generally not required.

Experience shows that zero point adjustment is advisable only in special cases:

- To achieve maximum measuring accuracy even with low flow rates
- Under extreme process or operating conditions (e.g. very high process temperatures or very high-viscosity fluids).

### Mounting Safety Barrier Promass 100

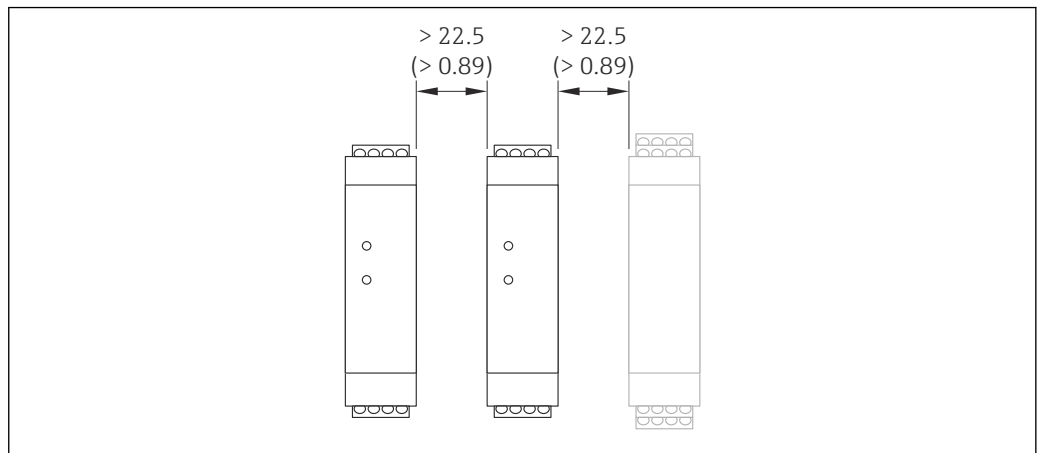

A0016894

21 Minimum distance between additional Safety Barrier Promass 100 or other modules. Engineering unit mm (in)

## Environment

Ambient temperature range	Measuring device	Non-Ex	-40 to +60 °C (-40 to +140 °F)
		Ex na, NI version	-40 to +60 °C (-40 to +140 °F)
		Ex ia, IS version	<ul style="list-style-type: none"> <li>■ -40 to +60 °C (-40 to +140 °F)</li> <li>■ -50 to +60 °C (-58 to +140 °F) (Order code for "Test, certificate", option JM)</li> </ul>
	Local display		-20 to +60 °C (-4 to +140 °F) The readability of the display may be impaired at temperatures outside the temperature range.
	Safety Barrier Promass 100		-40 to +60 °C (-40 to +140 °F)

- ▶ If operating outdoors:  
Avoid direct sunlight, particularly in warm climatic regions.

 Weather protection covers can be ordered from Endress+Hauser: see "Accessories" section

### Temperature tables

In the following tables, the following interdependencies between the maximum medium temperature for T1-T6 and the maximum ambient temperature  $T_a$  apply when operating the device in hazardous areas.

Ex ia, cCSA<sub>US</sub> IS

SI units

Order code for "Housing"	$T_a$ [°C]	T6 [85 °C]	T5 [100 °C]	T4 [135 °C]	T3 [200 °C]	T2 [300 °C]	T1 [450 °C]
Option A "Compact coated alu"	35	50	85	120	140	140	140
Option B "Compact hygienic, stainless"	50	–	85	120	140	140	140
	60	–	–	120	140	140	140
Option C "Ultra compact hygienic, stainless, M12 device plug"	35	50	85	120	140	140	140
	45	–	85	120	140	140	140
	50	–	–	120	140	140	140

US units

Order code for "Housing"	$T_a$ [°F]	T6 [185 °F]	T5 [212 °F]	T4 [275 °F]	T3 [392 °F]	T2 [572 °F]	T1 [842 °F]
Option A "Compact coated alu"	95	122	185	248	284	284	284
Option B "Compact hygienic, stainless"	122	–	185	248	284	284	284
	140	–	–	248	284	284	284
Option C "Ultra compact hygienic, stainless, M12 device plug"	95	122	185	248	284	284	284
	113	–	185	248	284	284	284
	122	–	–	248	284	284	284

Ex nA, cCSA<sub>US</sub> NI

SI units

Order code for "Housing"	$T_a$ [°C]	T6 [85 °C]	T5 [100 °C]	T4 [135 °C]	T3 [200 °C]	T2 [300 °C]	T1 [450 °C]
Option A "Compact coated alu"	35	50	85	120	140	140	140
Option B "Compact hygienic, stainless"	50	–	85	120	140	140	140
	60	–	–	120	140	140	140
Option C "Ultra compact hygienic, stainless, M12 device plug"	50	–	85	120	140	140	140
	60	–	–	120	140	140	140

US units

Order code for "Housing"	$T_a$ [°F]	T6 [185 °F]	T5 [212 °F]	T4 [275 °F]	T3 [392 °F]	T2 [572 °F]	T1 [842 °F]
Option A "Compact coated alu"	95	122	185	248	284	284	284
Option B "Compact hygienic, stainless"	122	–	185	248	284	284	284
	140	–	–	248	284	284	284
Option C "Ultra compact hygienic, stainless, M12 device plug"	122	–	185	248	284	284	284
	140	–	–	248	284	284	284



Explosion hazards arising from gas and dust

**Determining the temperature class and surface temperature with the temperature table**

- In the case of gas: Determine the temperature class as a function of the ambient temperature  $T_a$  and the medium temperature  $T_m$ .
- In the case of dust: Determine the maximum surface temperature as a function of the maximum ambient temperature  $T_a$  and the maximum medium temperature  $T_m$ .

**Example**

- Measured maximum ambient temperature:  $T_{ma} = 47\text{ °C}$
- Measured maximum medium temperature:  $T_{mm} = 108\text{ °C}$

	$T_a$ [°C]	$T_6$ [85°C]	$T_5$ [100°C]	$T_4$ [135°C]	$T_3$ [200°C]	$T_2$ [300°C]	$T_1$ [450°C]
	35	50	85	120	140	140	140
	50	-	85	120	140	140	140
	60	-	-	120	140	140	140
	35	50	85	120	140	140	140
	45	-	85	120	140	140	140
	50	-	-	120	140	140	140

Diagram annotations: 1. points to the 50°C row in the  $T_a$  column; 2. points to the 50°C cell in the  $T_a$  column; 3. points to the 120°C cell in the  $T_4$  column; 4. points to the 135°C value in the  $T_4$  column header.

22 Procedure for determining the maximum surface temperature

1. Select device.
2. In the column for the maximum ambient temperature  $T_a$  select the temperature that is immediately greater than or equal to the measured maximum ambient temperature  $T_{ma}$  that is present.
  - ↳  $T_a = 50\text{ °C}$ .
  - The row showing the maximum medium temperature is determined.
3. Select the maximum medium temperature  $T_m$  of this row, which is larger or equal to the measured maximum medium temperature  $T_{mm}$ .
  - ↳ The column with the temperature class for gas is determined:  $108\text{ °C} \leq 120\text{ °C} \rightarrow T_4$ .
4. The maximum temperature of the temperature class determined corresponds to the maximum surface temperature for dust:  $T_4 = 135\text{ °C}$

<b>Storage temperature</b>	-50 to +60 °C (-58 to +140 °F) (Order code for "Test, certificate", option JM)
<b>Climate class</b>	DIN EN 60068-2-38 (test Z/AD)
<b>Degree of protection</b>	<p><b>Transmitter and sensor</b></p> <ul style="list-style-type: none"> <li>■ As standard: IP66/67, type 4X enclosure</li> <li>■ With the order code for "Sensor options", option <b>CM</b>: IP69K can also be ordered</li> <li>■ When housing is open: IP20, type 1 enclosure</li> <li>■ Display module: IP20, type 1 enclosure</li> </ul> <p><b>Safety Barrier Promass 100</b> IP20</p>
<b>Shock resistance</b>	As per IEC/EN 60068-2-31
<b>Vibration resistance</b>	Acceleration up to 1 g, 10 to 150 Hz, based on IEC/EN 60068-2-6
<b>Interior cleaning</b>	<ul style="list-style-type: none"> <li>■ Sterilization in place (SIP)</li> <li>■ Cleaning in place (CIP)</li> </ul>

**Electromagnetic compatibility (EMC)**

- As per IEC/EN 61326 and NAMUR Recommendation 21 (NE 21)
- Complies with emission limits for industry as per EN 55011 (Class A)
- Device version with PROFIBUS DP: Complies with emission limits for industry as per EN 50170 Volume 2, IEC 61784

 The following applies for PROFIBUS DP: If baud rates > 1.5 Mbaud an EMC cable entry must be used and the cable shield must continue as far as the terminal wherever possible.

 For details refer to the Declaration of Conformity.

**Process****Medium temperature range****Sensor**

-40 to +140 °C (-40 to +284 °F)

**Seals**

No internal seals

**Density**

0 to 5 000 kg/m<sup>3</sup> (0 to 312 lb/cf)

**Pressure-temperature ratings**

The following pressure-temperature ratings refer to the entire device and not just the process connection.

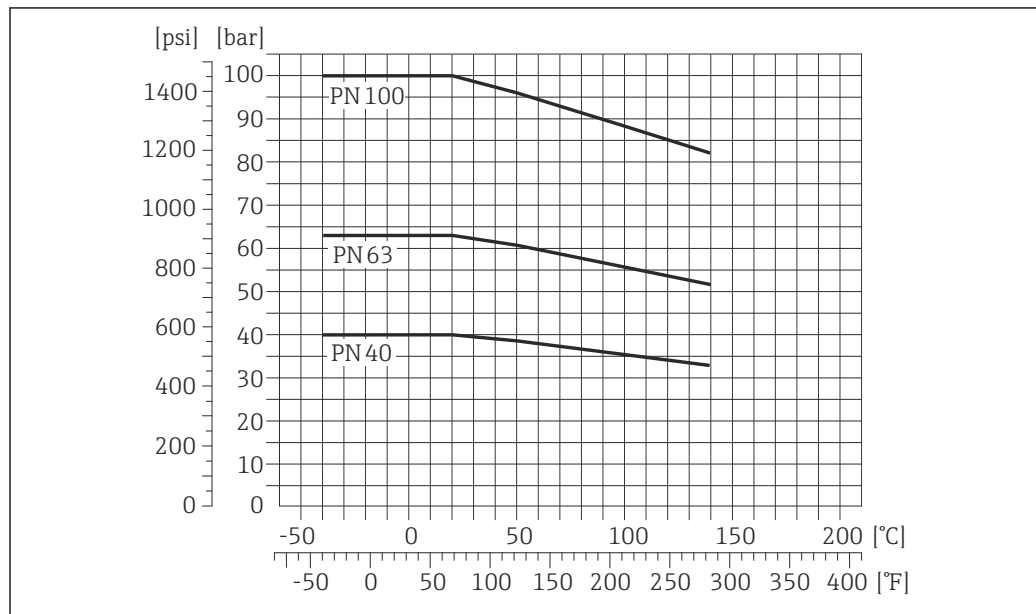
**Flange connection according to EN 1092-1 (DIN 2501)**

 23 With flange material 1.4404 (F316/F316L)

A0020972-EN

**Flange connection according to ASME B16.5**

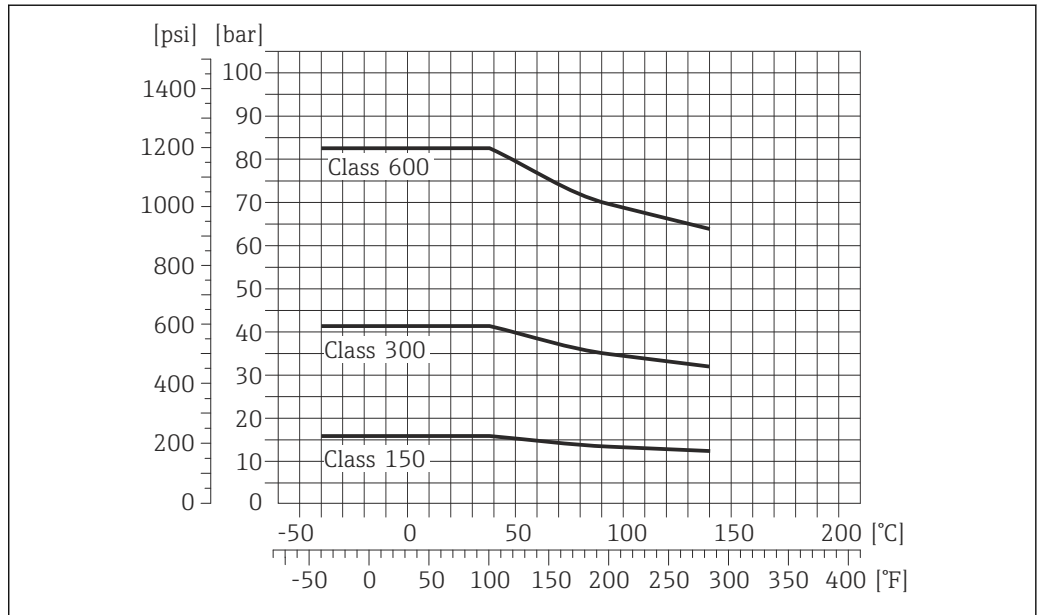

24 With flange material 1.4404 (F316/F316L)

**Flange connection according to JIS B2220**

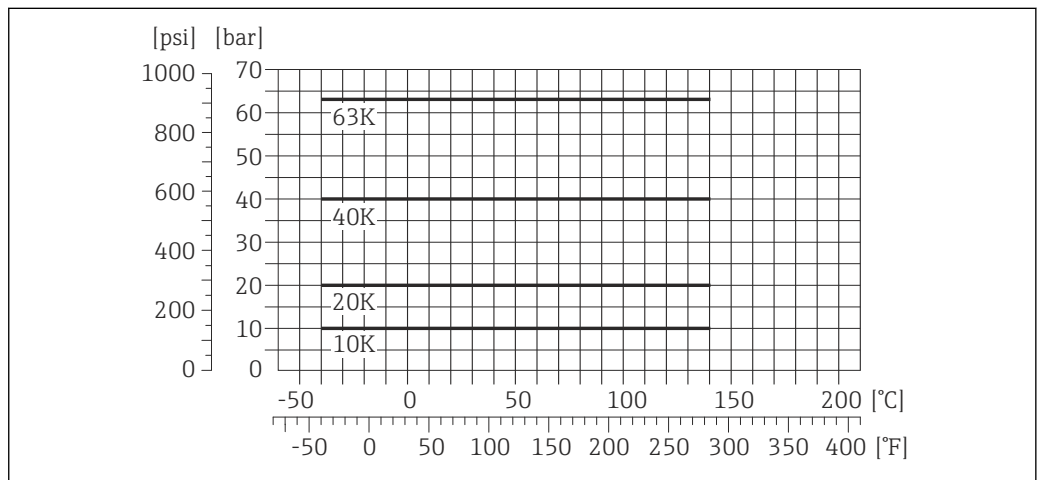

25 With flange material 1.4404 (F316/F316L)

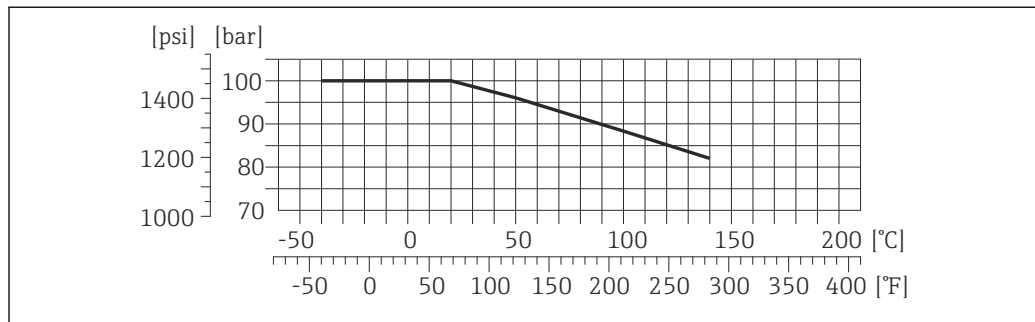
**VCO process connection**

A0020975-EN

26 With connection material 1.4404 (316/316L)

**Tri-Clamp**

The clamp connections are suitable up to a maximum pressure of 16 bar (232 psi). Please observe the operating limits of the clamp and seal used as they could be under 16 bar (232 psi). The clamp and seal are not included in the scope of supply.

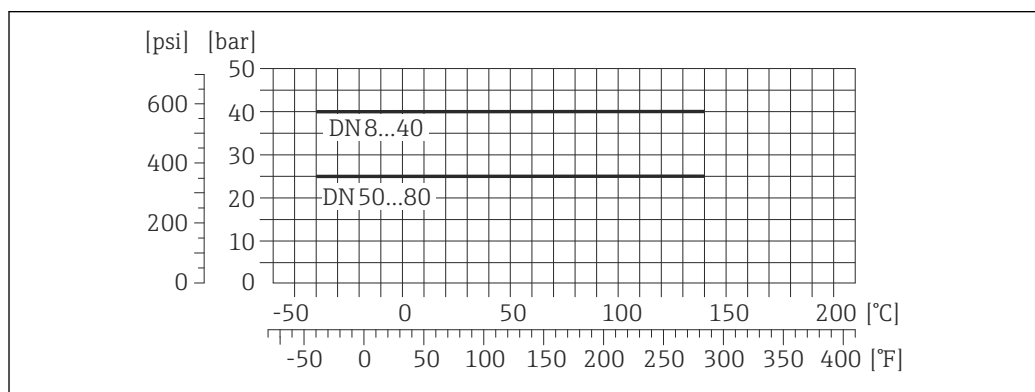
**Process connection to DIN 11851**

A0020976-EN

27 With connection material 1.4404 (316/316L)

DIN 11851 allows for applications up to +140 °C (+284 °F) if suitable sealing materials are used. Please take this into account when selecting seals and counterparts, as these components can limit the pressure and temperature range.

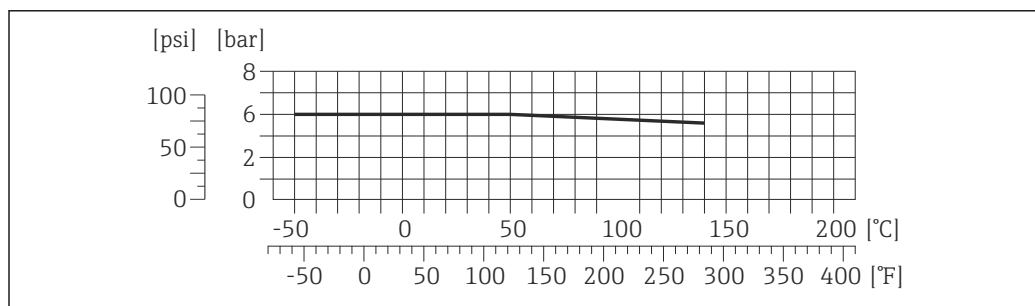
**Process connection to SMS 1145**

A0020986-EN

28 With connection material 1.4404 (316/316L)

SMS 1145 allows for applications up to 6 bar (87 psi) if suitable sealing materials are used. Please take this into account when selecting seals and counterparts, as these components can limit the pressure and temperature range.

**Aseptic threaded adapter as per DIN 11864-1 Form A**

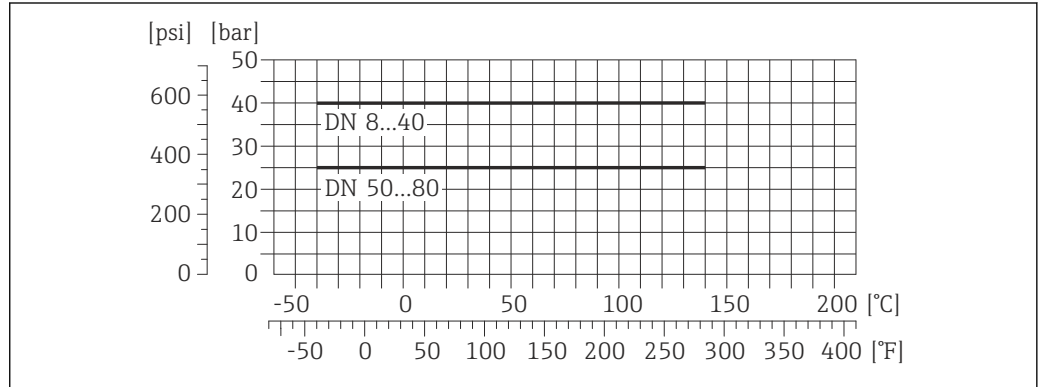

29 With connection material 1.4404 (316/316L)

**Aseptic flange connection according to DIN 11864-2 Form A**

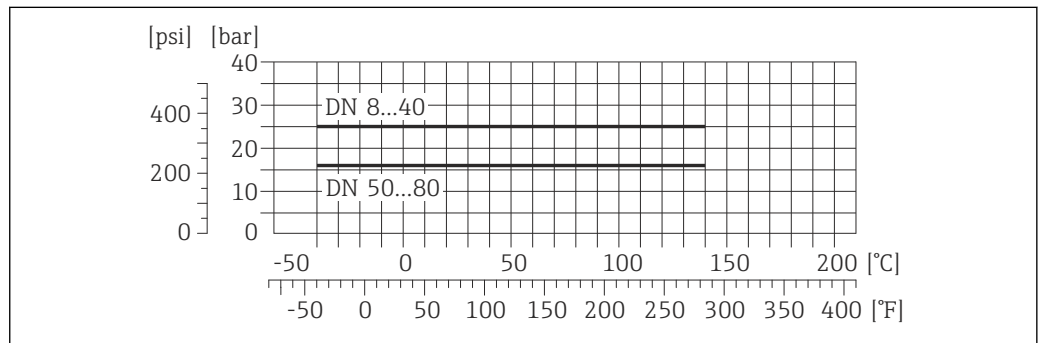

30 With flange material 1.4404 (316/316L)

**Threaded hygienic connection to ISO 2853**

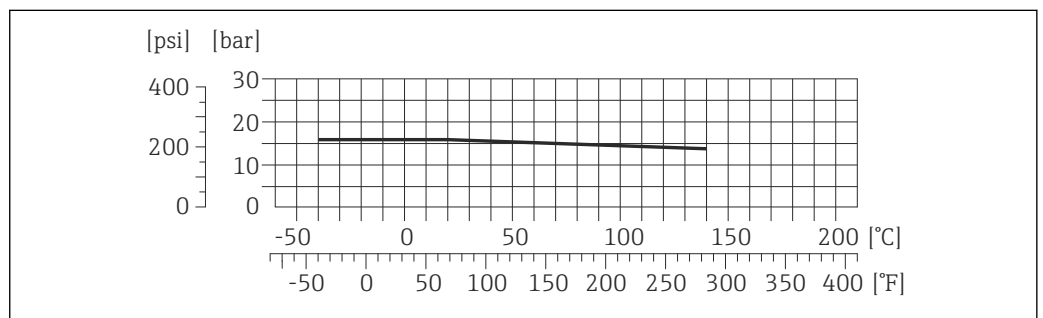

31 With connection material 1.4404 (316/316L)

**Secondary containment pressure rating**

The sensor housing is filled with dry nitrogen and protects the electronics and mechanics inside. The housing does not have pressure vessel classification. Reference value for the pressure loading capacity of the sensor housing: 16 bar (232 psi)

**Rupture disk**

To increase the level of safety, a device version with a rupture disk with a triggering pressure of 10 to 15 bar (145 to 217.5 psi) can be used. Special mounting instructions: (→ 38)

Rupture disks cannot be combined with the separately available heating jacket (→ 74) (→ 74).

### Flow limit

Select the nominal diameter by optimizing between the required flow range and permissible pressure loss.

**i** For an overview of the measuring range full scale values, see the "Measuring range" section (→ 8)

- The minimum recommended full scale value is approx. 1/20 of the maximum full scale value
- In most applications, 20 to 50 % of the maximum full scale value can be considered ideal
- Select a lower full scale value for abrasive substances (such as liquids with entrained solids): flow velocity < 1 m/s (< 3 ft/s).
- For gas measurement the following rules apply:
  - The flow velocity in the measuring tubes should not exceed half the sonic velocity (0.5 Mach).
  - The maximum mass flow depends on the density of the gas: formula (→ 8)

### Pressure loss

**i** To calculate the pressure loss, use the *Applicator* sizing tool (→ 75)

### System pressure

It is important that cavitation does not occur, or that gases entrained in the liquids do not outgas. This is prevented by means of a sufficiently high system pressure.

For this reason, the following mounting locations are recommended:

- At the lowest point in a vertical pipe
- Downstream from pumps (no danger of vacuum)

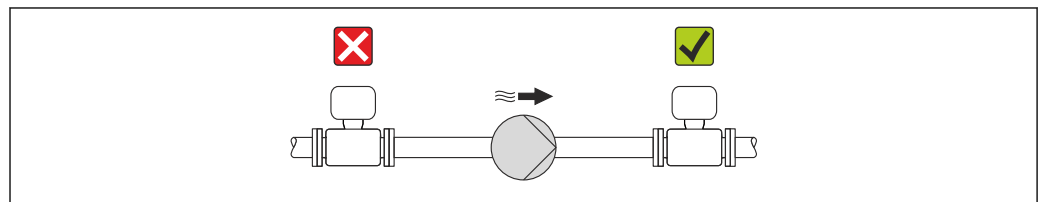

A0015594

### Thermal insulation

In the case of some fluids, it is important that the heat radiated from the sensor to the transmitter is kept to a minimum. A wide range of materials can be used for the required insulation.

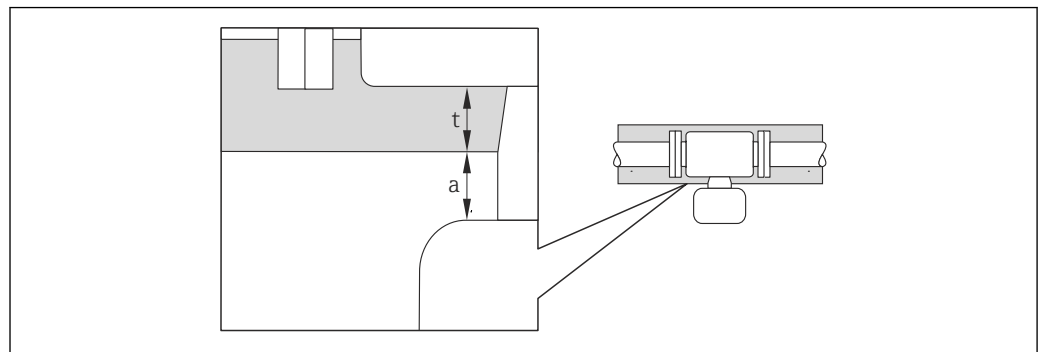

A0019919

*a* Minimum distance to insulation  
*t* Insulation thickness

The minimum distance between the transmitter housing and the insulation is 10 mm (0.39 in) so that the transmitter head remains completely exposed.

### NOTICE

**The insulation can also be thicker than the recommended insulation thickness.**

Prerequisite:

- ▶ The temperature at the lower end of the transmitter housing does not exceed 80 °C (176 °F)
- ▶ Ensure that convection takes place on a sufficiently large scale at the transmitter neck.
- ▶ Ensure that a sufficiently large area of the housing support remains exposed. The uncovered part serves as a radiator and protects the electronics from overheating and excessive cooling.

---

### Heating

Some fluids require suitable measures to avoid loss of heat at the sensor.

#### Heating options

- Electrical heating, e.g. with electric band heaters
- Via pipes carrying hot water or steam
- Via heating jackets



Heating jackets for the sensor can be ordered as accessories from Endress+Hauser (→  74).

---

### Vibrations

The high oscillation frequency of the measuring tubes ensures that the correct operation of the measuring system is not influenced by plant vibrations.

## Mechanical construction

### Design, dimensions

#### Compact version

Order code for "Housing", option A "Compact coated alu"

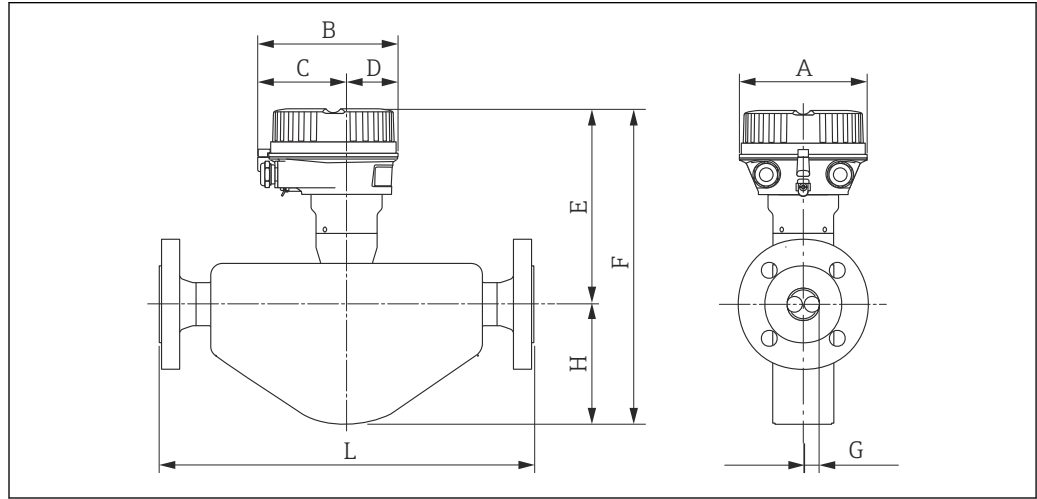

A0016394

#### Dimensions SI units

DN [mm]	A [mm]	B [mm]	C [mm]	D [mm]	E <sup>1)</sup> [mm]	F <sup>1)</sup> [mm]	G [mm]	H [mm]	L [mm]
8	136	147.5	93.5	54	179	272	5.35	93	<sup>2)</sup>
15	136	147.5	93.5	54	181	286	8.30	105	<sup>2)</sup>
25	136	147.5	93.5	54	186	292	12.0	106	<sup>2)</sup>
40	136	147.5	93.5	54	192	313	17.6	121	<sup>2)</sup>
50	136	147.5	93.5	54	208	377.5	26.0	169.5	<sup>2)</sup>
80	136	147.5	93.5	54	213.5	418.5	40.5	205	<sup>2)</sup>

1) If using a display, order code for "Display; Operation", option B: values +28 mm

2) dependent on respective process connection

#### Dimensions US units

DN [in]	A [in]	B [in]	C [in]	D [in]	E <sup>1)</sup> [in]	F <sup>1)</sup> [in]	G [in]	H [in]	L [in]
$\frac{3}{8}$	5.35	5.81	3.68	2.13	7.05	10.71	0.21	3.66	<sup>2)</sup>
$\frac{1}{2}$	5.35	5.81	3.68	2.13	7.13	11.26	0.33	4.13	<sup>2)</sup>
1	5.35	5.81	3.68	2.13	7.32	11.5	0.47	4.17	<sup>2)</sup>
1½	5.35	5.81	3.68	2.13	7.56	12.32	0.69	4.76	<sup>2)</sup>
2	5.35	5.81	3.68	2.13	8.19	14.86	1.02	6.67	<sup>2)</sup>
3	5.35	5.81	3.68	2.13	8.41	16.48	1.59	8.07	<sup>2)</sup>

1) If using a display, order code for "Display; Operation", option B: values +1.1 in

2) dependent on respective process connection



Order code for "Housing", option B "Compact hygienic, stainless"

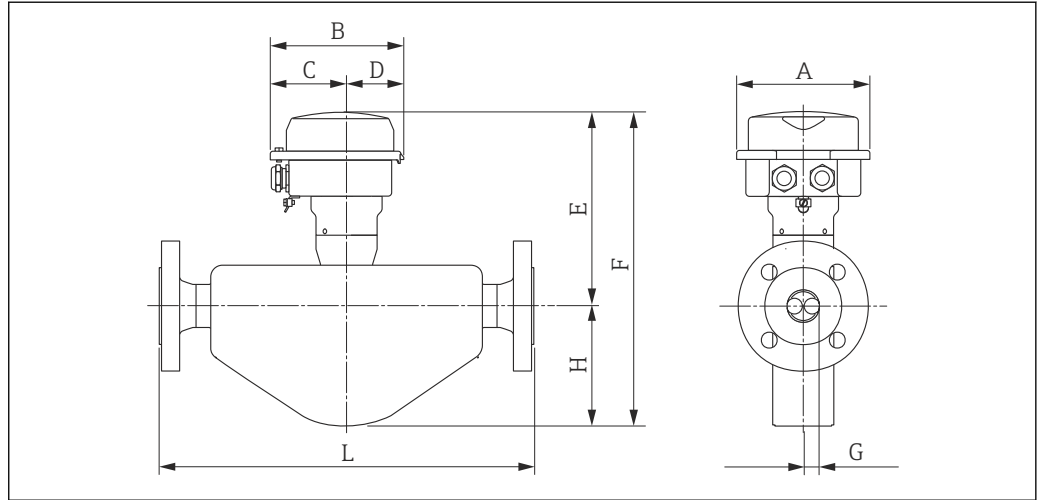

A0016396

Dimensions SI units

DN [mm]	A [mm]	B [mm]	C [mm]	D [mm]	E <sup>1)</sup> [mm]	F <sup>1)</sup> [mm]	G [mm]	H [mm]	L [mm]
8	133.5	136.8	78	58.8	174	267	5.35	93	<sup>2)</sup>
15	133.5	136.8	78	58.8	176	281	8.30	105	<sup>2)</sup>
25	133.5	136.8	78	58.8	181	287	12.0	106	<sup>2)</sup>
40	133.5	136.8	78	58.8	187	308	17.6	121	<sup>2)</sup>
50	133.5	136.8	78	58.8	203	372.5	26.0	169.5	<sup>2)</sup>
80	133.5	136.8	78	58.8	208.5	413.5	40.5	205	<sup>2)</sup>

- 1) If using a display, order code for "Display; Operation", option B: values +14 mm
- 2) dependent on respective process connection

Dimensions US units

DN [in]	A [in]	B [in]	C [in]	D [in]	E <sup>1)</sup> [in]	F <sup>1)</sup> [in]	G [in]	H [in]	L [in]
<sup>3</sup> / <sub>8</sub>	5.26	5.39	3.07	2.31	6.85	10.51	0.21	3.66	<sup>2)</sup>
<sup>1</sup> / <sub>2</sub>	5.26	5.39	3.07	2.31	6.93	11.06	0.33	4.13	<sup>2)</sup>
1	5.26	5.39	3.07	2.31	7.13	11.3	0.47	4.17	<sup>2)</sup>
1½	5.26	5.39	3.07	2.31	7.36	12.13	0.69	4.76	<sup>2)</sup>
2	5.26	5.39	3.07	2.31	7.99	14.67	1.02	6.67	<sup>2)</sup>
3	5.26	5.39	3.07	2.31	8.21	16.28	1.59	8.07	<sup>2)</sup>

- 1) If using a display, order code for "Display; Operation", option B: values +0.55 in
- 2) dependent on respective process connection

Order code for "Housing", option C "Ultra compact hygienic, stainless, M12 device plug"

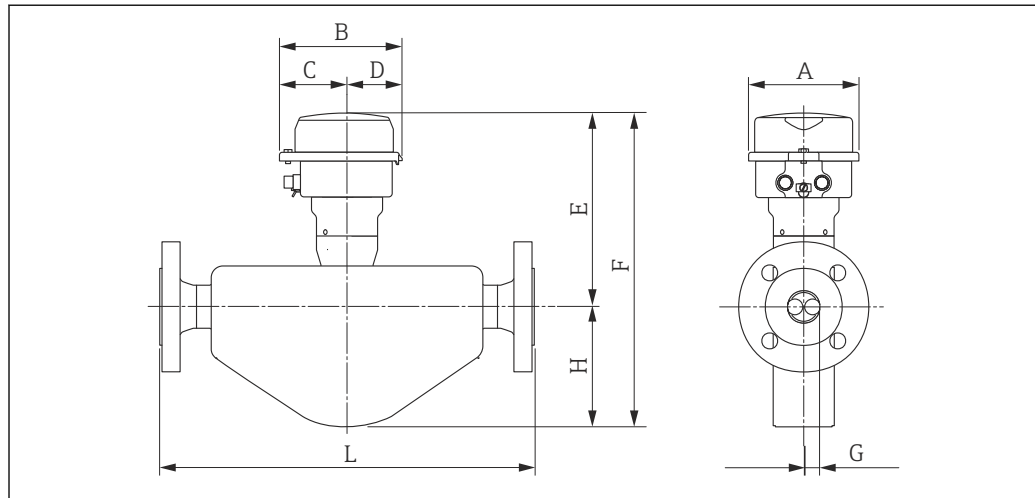

A0016395

*Dimensions SI units*

DN [mm]	A [mm]	B [mm]	C [mm]	D [mm]	E <sup>1)</sup> [mm]	F <sup>1)</sup> [mm]	G [mm]	H [mm]	L [mm]
8	111.4	123.6	67.7	55.9	174	267	5.35	93	<sup>2)</sup>
15	111.4	123.6	67.7	55.9	176	281	8.30	105	<sup>2)</sup>
25	111.4	123.6	67.7	55.9	181	287	12.0	106	<sup>2)</sup>
40	111.4	123.6	67.7	55.9	187	308	17.6	121	<sup>2)</sup>
50	111.4	123.6	67.7	55.9	203	372.5	26.0	169.5	<sup>2)</sup>
80	111.4	123.6	67.7	55.9	208.5	413.5	40.5	205	<sup>2)</sup>

- 1) If using a display, order code for "Display; Operation", option B: values +14 mm  
 2) dependent on respective process connection

*Dimensions US units*

DN [in]	A [in]	B [in]	C [in]	D [in]	E <sup>1)</sup> [in]	F <sup>1)</sup> [in]	G [in]	H [in]	L [in]
$\frac{3}{8}$	4.39	4.87	2.67	2.2	6.85	10.51	0.21	3.66	<sup>2)</sup>
$\frac{1}{2}$	4.39	4.87	2.67	2.2	6.93	11.06	0.33	4.13	<sup>2)</sup>
1	4.39	4.87	2.67	2.2	7.13	11.3	0.47	4.17	<sup>2)</sup>
1½	4.39	4.87	2.67	2.2	7.36	12.13	0.69	4.76	<sup>2)</sup>
2	4.39	4.87	2.67	2.2	7.99	14.67	1.02	6.67	<sup>2)</sup>
3	4.39	4.87	2.67	2.2	8.21	16.28	1.59	8.07	<sup>2)</sup>

- 1) If using a display, order code for "Display; Operation", option B: values +0.55 in  
 2) dependent on respective process connection

**Process connections in SI units**

*Flange connections EN (DIN)*

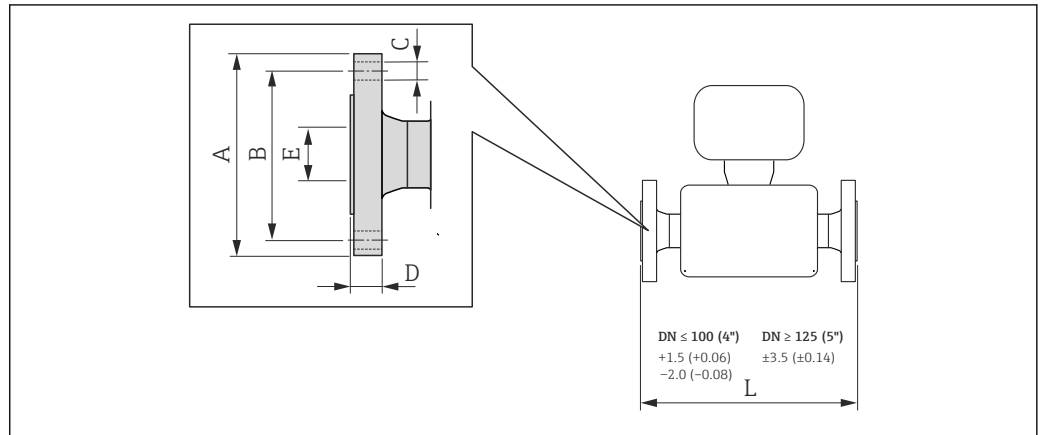

A0015621

32 Engineering unit mm (in)

**Flange according to EN 1092-1 (DIN 2501 / DIN 2512N <sup>1)</sup>), PN 40: 1.4404 (F316/F316L) (order code for "Process connection", option D2S)**  
**Surface roughness (flange): EN 1092-1 Form B1 (DIN 2526 Form C), Ra 3.2 to 12.5 µm**

DN [mm]	A [mm]	B [mm]	C [mm]	D [mm]	E [mm]	L [mm]
8 <sup>2)</sup>	95	65	4 × Ø14	16	17.3	232/510 <sup>3)</sup>
15	95	65	4 × Ø14	16	17.3	279/510 <sup>3)</sup>
25	115	85	4 × Ø14	18	28.5	329/600 <sup>3)</sup>
40	150	110	4 × Ø18	18	43.1	445
50	165	125	4 × Ø18	20	54.5	556/715 <sup>3)</sup>
80	200	160	8 × Ø18	24	82.5	610/915 <sup>3)</sup>

- 1) Flange with groove according to EN 1092-1 Form D (DIN 2512N) available (order code for "Process connection", option D6S)
- 2) DN 8 with DN 15 flanges as standard
- 3) Installation length in accordance with NAMUR recommendation NE 132 optionally available (order code for "Process connection", option D2N or D6N (with groove))

**Flange according to EN 1092-1 (DIN 2501), PN 40 (with DN 25 flanges): 1.4404 (F316/F316L) (order code for "Process connection", option R2S)**  
**Surface roughness (flange): EN 1092-1 Form B1 (DIN 2526 Form C), Ra 3.2 to 12.5 µm**

DN [mm]	A [mm]	B [mm]	C [mm]	D [mm]	E [mm]	L [mm]
8	115	85	4 × Ø14	18	28.5	329
15	115	85	4 × Ø14	18	28.5	329

**Flange according to EN 1092-1 (DIN 2501 / DIN 2512N<sup>1)</sup>), PN 63: 1.4404 (F316/F316L) (order code for "Process connection", option D3S)**

**Surface roughness (flange): EN 1092-1 Form B2 (DIN 2526 Form E), Ra 0.8 to 3.2 µm**

DN [mm]	A [mm]	B [mm]	C [mm]	D [mm]	E [mm]	L [mm]
50	180	135	4 × Ø22	26	54.5	565
80	215	170	8 × Ø22	28	81.7	650

- 1) Flange with groove according to EN 1092-1 Form D (DIN 2512N) available (order code for "Process connection", option D7S)

**Flange according to EN 1092-1 (DIN 2501 / DIN 2512N<sup>1)</sup>), PN 100: 1.4404 (F316/F316L) (order code for "Process connection", option D4S)**

**Surface roughness (flange): EN 1092-1 Form B2 (DIN 2526 Form E), Ra 0.8 to 3.2 µm**

DN [mm]	A [mm]	B [mm]	C [mm]	D [mm]	E [mm]	L [mm]
8 <sup>2)</sup>	105	75	4 × Ø14	20	17.3	261
15	105	75	4 × Ø14	20	17.3	295
25	140	100	4 × Ø18	24	28.5	360
40	170	125	4 × Ø22	26	42.5	486
50	195	145	4 × Ø26	28	53.9	581
80	230	180	8 × Ø26	32	80.9	660

- 1) Flange with groove according to EN 1092-1 Form D (DIN 2512N) available (order code for "Process connection", option D8S)
- 2) DN 8 with DN 15 flanges as standard

*Flange connections ASME B16.5*

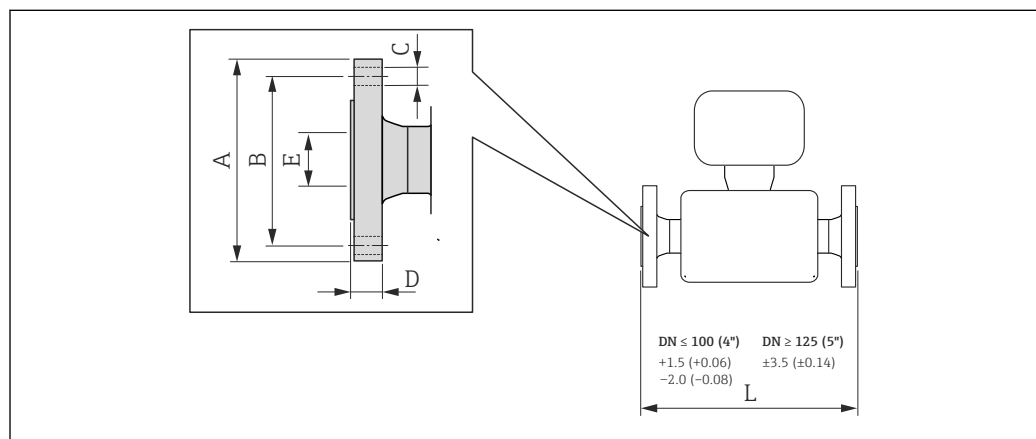

33 Engineering unit mm (in)

**Flange according to ASME B16.5, Cl 150: 1.4404 (F316/F316L) (order code for "Process connection", option AAS)**

DN [mm]	A [mm]	B [mm]	C [mm]	D [mm]	E [mm]	L [mm]
8 <sup>1)</sup>	90	60.3	4 × Ø15.7	11.2	15.7	232
15	90	60.3	4 × Ø15.7	11.2	15.7	279
25	110	79.4	4 × Ø15.7	14.2	26.7	329

Flange according to ASME B16.5, Cl 150: 1.4404 (F316/F316L) (order code for "Process connection", option AAS)						
DN [mm]	A [mm]	B [mm]	C [mm]	D [mm]	E [mm]	L [mm]
40	125	98.4	4 × Ø15.7	17.5	40.9	445
50	150	120.7	4 × Ø19.1	19.1	52.6	556
80	190	152.4	4 × Ø19.1	23.9	78.0	610

1) DN 8 with DN 15 flanges as standard

Flange according to ASME B16.5, Cl 300: 1.4404 (F316/F316L) (order code for "Process connection", option ABS)						
DN [mm]	A [mm]	B [mm]	C [mm]	D [mm]	E [mm]	L [mm]
8 <sup>1)</sup>	95	66.7	4 × Ø15.7	14.2	15.7	232
15	95	66.7	4 × Ø15.7	14.2	15.7	279
25	125	88.9	4 × Ø19.0	17.5	26.7	329
40	155	114.3	4 × Ø22.3	20.6	40.9	445
50	165	127	8 × Ø19.0	22.3	52.6	556
80	210	168.3	8 × Ø22.3	28.4	78.0	610

1) DN 8 with DN 15 flanges as standard

Flange according to ASME B16.5, Cl 600: 1.4404 (F316/F316L) (order code for "Process connection", option ACS)						
DN [mm]	A [mm]	B [mm]	C [mm]	D [mm]	E [mm]	L [mm]
8 <sup>1)</sup>	95	66.7	4 × Ø15.7	20.6	13.9	261
15	95	66.7	4 × Ø15.7	20.6	13.9	295
25	125	88.9	4 × Ø19.1	23.9	24.3	380
40	155	114.3	4 × Ø22.4	28.7	38.1	496
50	165	127	8 × Ø19.1	31.8	49.2	583
80	210	168.3	8 × Ø22.4	38.2	73.7	672

1) DN 8 with DN 15 flanges as standard

## Flange connections JIS

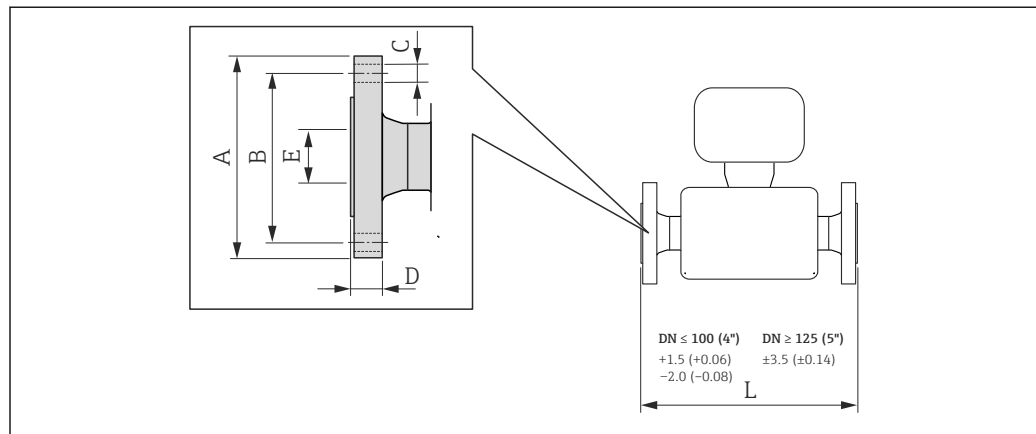

A0015621

34 Engineering unit mm (in)

Flange JIS B2220, 10K: 1.4404 (F316/F316L) (order code for "Process connection", option NDS)						
DN [mm]	A [mm]	B [mm]	C [mm]	D [mm]	E [mm]	L [mm]
50	155	120	4 × Ø19	16	50	556
80	185	150	8 × Ø19	18	80	605

Flange JIS B2220, 20K: 1.4404 (F316/F316L) (order code for "Process connection", option NES)						
DN [mm]	A [mm]	B [mm]	C [mm]	D [mm]	E [mm]	L [mm]
8 <sup>1)</sup>	95	70	4 × Ø15	14	15	232
15	95	70	4 × Ø15	14	15	279
25	125	90	4 × Ø19	16	25	329
40	140	105	4 × Ø19	18	40	445
50	155	120	8 × Ø19	18	50	556
80	200	160	8 × Ø23	22	80	605

1) DN 8 with DN 15 flanges as standard

Flange JIS B2220, 40K: 1.4404 (F316/F316L) (order code for "Process connection", option NGS)						
DN [mm]	A [mm]	B [mm]	C [mm]	D [mm]	E [mm]	L [mm]
8 <sup>1)</sup>	115	80	4 × Ø19	20	15	261
15	115	80	4 × Ø19	20	15	300
25	130	95	4 × Ø19	22	25	375
40	160	120	4 × Ø23	24	38	496
50	165	130	8 × Ø19	26	50	601
80	210	170	8 × Ø23	32	75	662

1) DN 8 with DN 15 flanges as standard

Flange JIS B2220, 63K: 1.4404 (F316/F316L) (order code for "Process connection", option NHS)						
DN [mm]	A [mm]	B [mm]	C [mm]	D [mm]	E [mm]	L [mm]
8 <sup>1)</sup>	120	85	4 × Ø19	23	12	282
15	120	85	4 × Ø19	23	12	315
25	140	100	4 × Ø23	27	22	383
40	175	130	4 × Ø25	32	35	515
50	185	145	4 × Ø23	34	48	616
80	230	185	4 × Ø25	40	73	687

1) DN 8 with DN 15 flanges as standard

VCO connections

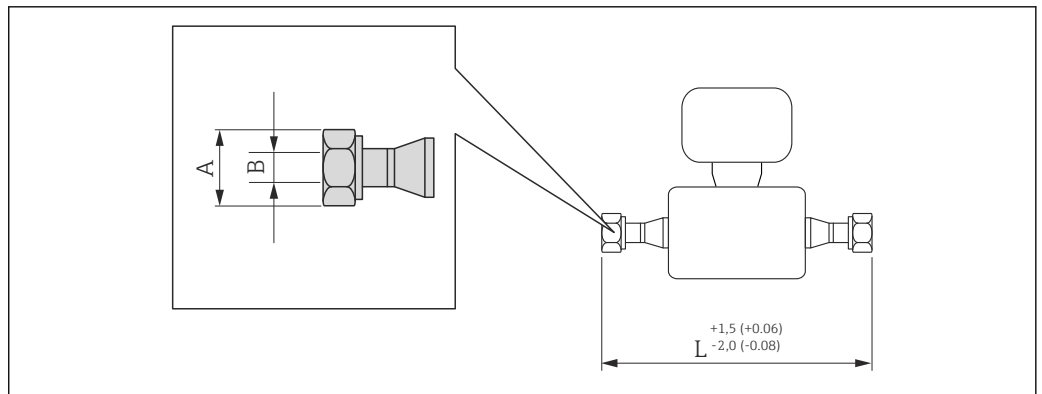

A0015624

35 Engineering unit mm (in)

VCO connections: 1.4404 (316/316L)			
DN [mm]	A [in]	B [mm]	L [mm]
8 <sup>1)</sup>	AF 1	10.2	252
15 <sup>2)</sup>	AF 1½	15.7	305

1) 8-VCO-4 (½"): (order code for "Process connection", option CVS)

2) 12-VCO-4 (¾"): (order code for "Process connection", option CWS)

Tri-Clamp

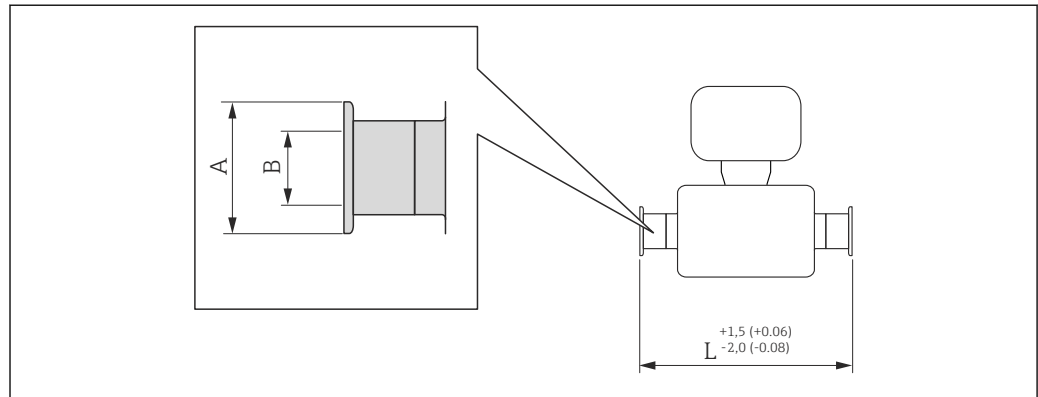

A0015625

36 Engineering unit mm (in)

<b>1", 1½", 2" Tri-Clamp for pipe size: 1.4404 (316/316L) (order code for "Process connection", option FTS)</b>				
DN [mm]	Clamp [in]	A [mm]	B [mm]	L [mm]
8	1	50.4	22.1	229
15	1	50.4	22.1	273
25	1	50.4	22.1	324
40	1½	50.4	34.8	456
50	2	63.9	47.5	562
80	3	90.9	72.9	672

3A version available (order code for "Additional approval", option LP) in combination with  $Ra \leq 0.8 \mu\text{m}$ ,  $Ra \leq 0.4 \mu\text{m}$  (order code for "Measuring tube material", option SB, SC)

<b>½"-Tri-Clamp: 1.4404 (316/316L) (order code for "Process connection", option FDW)</b>				
DN [mm]	Clamp [in]	A [mm]	B [mm]	L [mm]
8	½	25.0	9.5	229
15	½	25.0	9.5	273

3A version available (order code for "Additional approval", option LP) in combination with  $Ra \leq 0.8 \mu\text{m}$ ,  $Ra \leq 0.4 \mu\text{m}$  (order code for "Measuring tube material", option SB, SC)



DIN 11851 (sanitary connection)

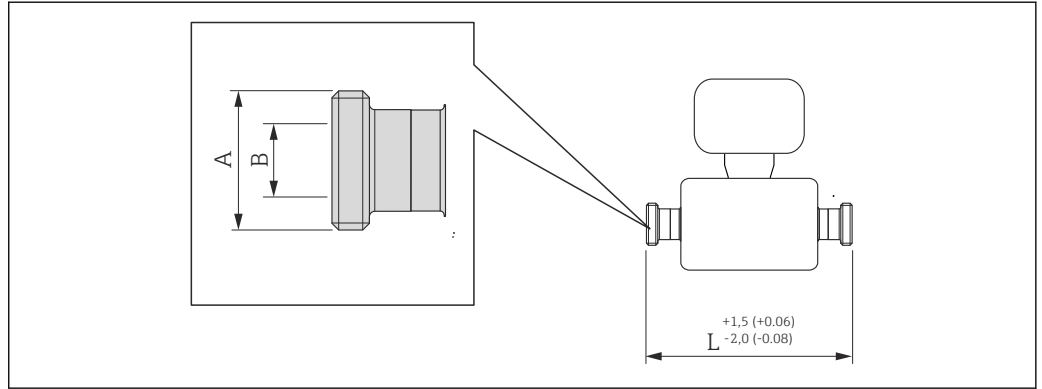

A0015628

37 Engineering unit mm (in)

**Sanitary connection DIN 11851: 1.4404 (316/316L) (order code for "Process connection", option FMW)**

DN [mm]	A [in]	B [mm]	L [mm]
8	Rd 34 × 1/8	16	229
15	Rd 34 × 1/8	16	273
25	Rd 52 × 1/6	26	324
40	Rd 65 × 1/6	38	456
50	Rd 78 × 1/6	50	562
80	Rd 110 × 1/4	81	672

3A version available (order code for "Additional approval", option LP) in combination with Ra ≤ 0.8 μm (order code for "Measuring tube material", option SB)

DIN 11864-1 Form A (threaded hygienic connection)

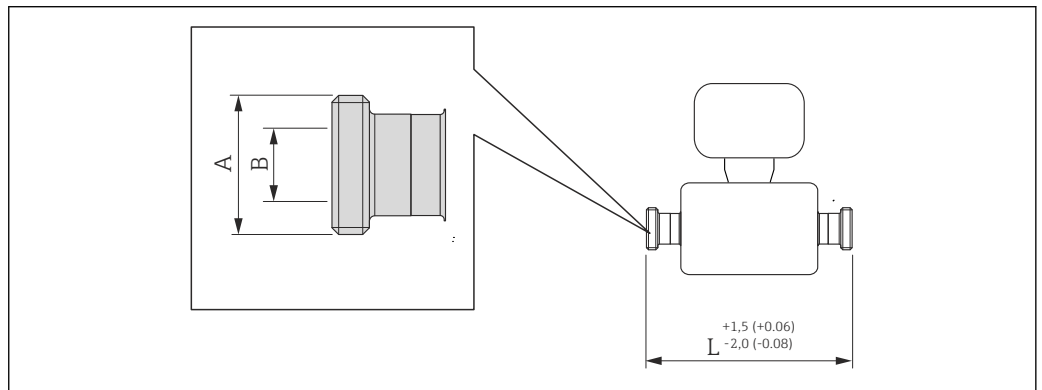

A0015628

38 Engineering unit mm (in)

**Threaded hygienic connection DIN 11864-1 Form A: 1.4404 (316/316L) (order code for "Process connection", option FLW)**

DN [mm]	A [in]	B [mm]	L [mm]
8	Rd 28 × 1/8	10	229
15	Rd 34 × 1/8	16	273

Threaded hygienic connection DIN 11864-1 Form A: 1.4404 (316/316L) (order code for "Process connection", option FLW)			
DN [mm]	A [in]	B [mm]	L [mm]
25	Rd 52 × 1/6	26	324
40	Rd 65 × 1/6	38	456
50	Rd 78 × 1/6	50	562
80	Rd 110 × 1/4	81	672

3A version available (order code for "Additional approval", option LP) in combination with Ra ≤ 0.8 µm (order code for "Measuring tube material", option SB)

DIN 11864-2 Form A (flange with groove)

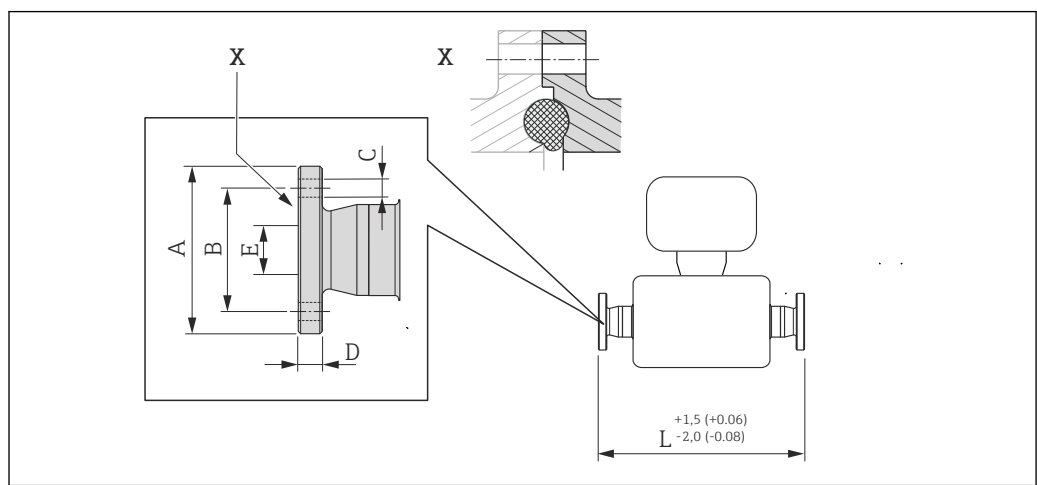

A0015627

39 Detail X: Asymmetrical process connection; the part shown in gray is provided by the supplier. Engineering unit mm (in).

DIN 11864-2 Form A (flange with groove): 1.4404 (316/316L) (order code for "Process connection", option KCS)						
DN [mm]	A [mm]	B [mm]	C [mm]	D [mm]	E [mm]	L [mm]
8	54	37	4 × Ø9	10	10	249
15	59	42	4 × Ø9	10	16	293
25	70	53	4 × Ø9	10	26	344
40	82	65	4 × Ø9	10	38	456
50	94	77	4 × Ø9	10	50	562
80	133	112	8 × Ø11	12	81	672

3A version available (order code for "Additional approval", option LP) in combination with Ra ≤ 0.8 µm (order code for "Measuring tube material", option SB)

ISO 2853 (threaded hygienic connection)

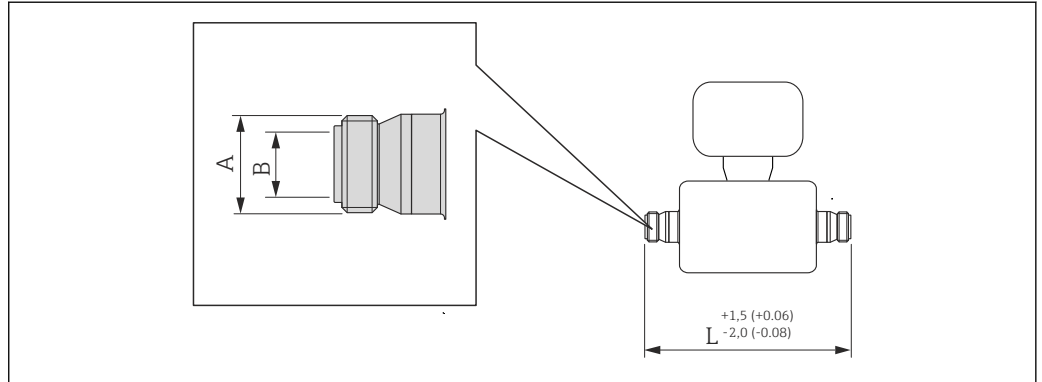

A0015623

40 Engineering unit mm (in)

Threaded hygienic connection ISO 2853: 1.4404 (316/316L) (order code for "Process connection", option JSF)			
DN [mm]	A <sup>1)</sup> [mm]	B [mm]	L [mm]
8	37.13	22.6	229
15	37.13	22.6	273
25	37.13	22.6	324
40	50.68	35.6	456
50	64.16	48.6	562
80	91.19	72.9	672

3A version available (order code for "Additional approval", option LP) in combination with Ra ≤ 0.8 μm (order code for "Measuring tube material", option SB)

1) Max. thread diameter as per ISO 2853 Annex A

SMS 1145 (threaded hygienic connection)

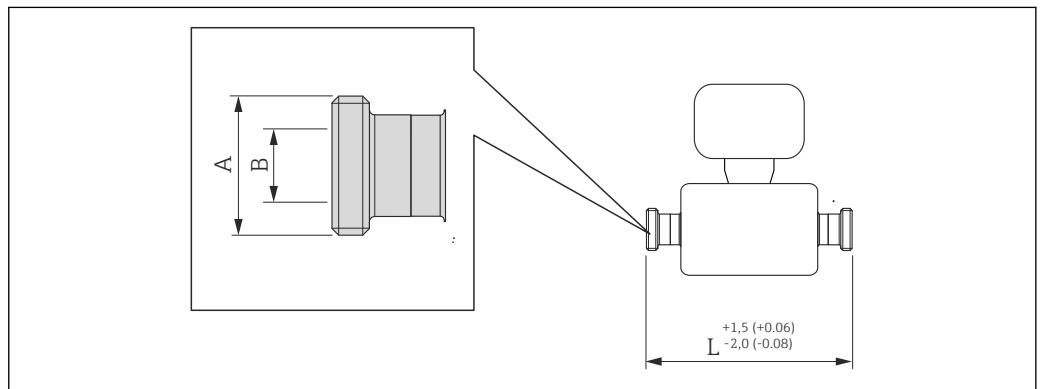

A0015628

41 Engineering unit mm (in)

Threaded hygienic connection SMS 1145: 1.4404 (316/316L) (order code for "Process connection", option SCS)			
DN [mm]	A [in]	B [mm]	L [mm]
8	Rd 40 × 1/6	22.5	229
15	Rd 40 × 1/6	22.5	273
25	Rd 40 × 1/6	22.5	324
40	Rd 60 × 1/6	35.5	456
50	Rd 70 × 1/6	48.5	562
80	Rd 98 × 1/6	72.9	672

3A version available (order code for "Additional approval", option LP) in combination with Ra ≤ 0.8 µm (order code for "Measuring tube material", option SB)

**Process connections in US units**

*Flange connections ASME B16.5*

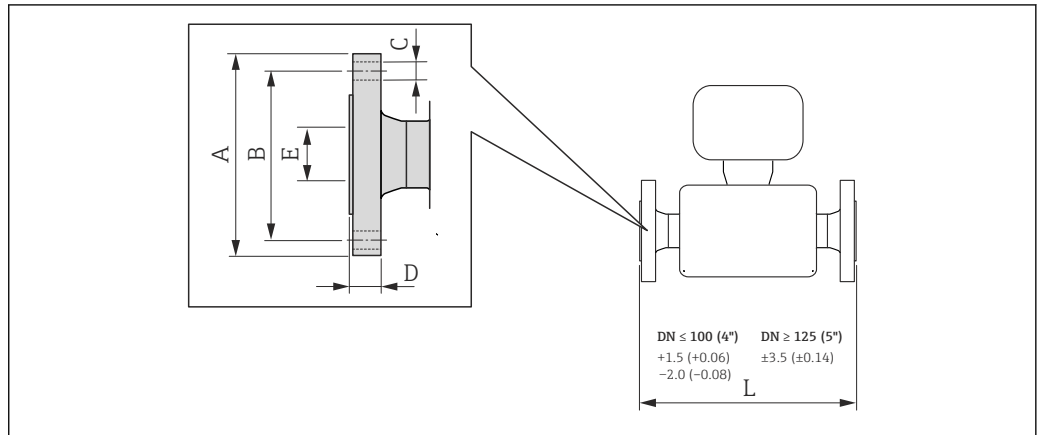

A0015621

42 Engineering unit mm (in)

**Flange according to ASME B16.5, CI 150: 1.4404 (F316/F316L) (order code for "Process connection", option AAS)**

DN [in]	A [in]	B [in]	C [in]	D [in]	E [in]	L [in]
$\frac{3}{8}$ <sup>1)</sup>	3.54	2.37	4 × Ø0.62	0.44	0.62	9.13
$\frac{1}{2}$	3.54	2.37	4 × Ø0.62	0.44	0.62	10.98
1	4.33	3.13	4 × Ø0.62	0.56	1.05	12.95
1½	4.92	3.87	4 × Ø0.62	0.69	1.61	17.52
2	5.91	4.75	4 × Ø0.75	0.75	2.07	21.89
3	7.48	6.00	4 × Ø0.75	0.94	3.07	24.02

1) DN  $\frac{3}{8}$ " with DN  $\frac{1}{2}$ " flanges as standard

**Flange according to ASME B16.5, CI 300: 1.4404 (F316/F316L) (order code for "Process connection", option ABS)**

DN [in]	A [in]	B [in]	C [in]	D [in]	E [in]	L [in]
$\frac{3}{8}$ <sup>1)</sup>	3.74	2.63	4 × Ø0.62	0.56	0.62	9.13
$\frac{1}{2}$	3.74	2.63	4 × Ø0.62	0.56	0.62	10.98
1	4.92	3.50	4 × Ø0.75	0.69	1.05	12.95
1½	6.10	4.50	4 × Ø0.88	0.81	1.61	17.52
2	6.50	5.00	8 × Ø0.75	0.88	2.07	21.89
3	8.27	6.63	8 × Ø0.88	1.12	3.07	24.02

1) DN  $\frac{3}{8}$ " with DN  $\frac{1}{2}$ " flanges as standard

Flange according to ASME B16.5, Cl 600: 1.4404 (F316/F316L) (order code for "Process connection", option ACS)						
DN [in]	A [in]	B [in]	C [in]	D [in]	E [in]	L [in]
$\frac{3}{8}$ <sup>1)</sup>	3.74	2.63	4 × Ø0.62	0.81	0.55	10.28
$\frac{1}{2}$	3.74	2.63	4 × Ø0.62	0.81	0.55	11.61
1	4.92	3.50	4 × Ø0.75	0.94	0.96	14.96
1½	6.10	4.50	4 × Ø0.88	1.13	1.50	19.53
2	6.50	5.00	8 × Ø0.75	1.25	1.94	22.95
3	8.27	6.63	8 × Ø0.88	1.50	2.90	24.46

1) DN  $\frac{3}{8}$ " with DN  $\frac{1}{2}$ " flanges as standard

VCO connections

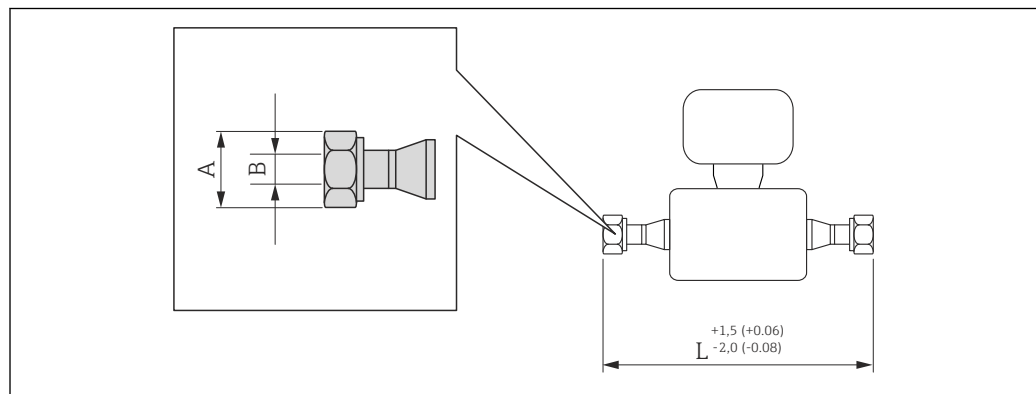

A0015624

43 Engineering unit mm (in)

VCO connections: 1.4404 (316/316L)			
DN [mm]	A [in]	B [in]	L [in]
$\frac{3}{8}$ <sup>1)</sup>	AF 1	0.40	9.92
$\frac{1}{2}$ <sup>2)</sup>	AF 1½	0.62	12.01

- 1) 8-VCO-4 ( $\frac{1}{2}$ " ): (order code for "Process connection", option CVS)
- 2) 12-VCO-4 ( $\frac{3}{4}$ " ): (order code for "Process connection", option CWS)

Tri-Clamp

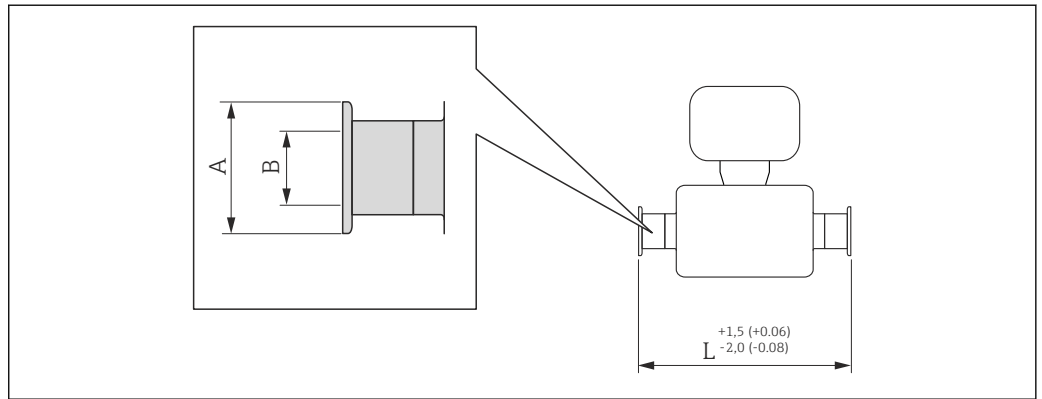

A0015625

44 Engineering unit mm (in)

<b>1", 1½", 2" Tri-Clamp for pipe size: 1.4404 (316/316L) (order code for "Process connection", option FTS)</b>				
DN [in]	Clamp [in]	A [in]	B [in]	L [in]
¾	1	1.98	0.87	9.02
½	1	1.98	0.87	10.75
1	1	1.98	0.87	12.76
1½	1½	1.98	1.37	17.95
2	2	2.52	1.87	22.13
3	3	3.58	2.87	26.46

3A version available (order code for "Additional approval", option LP) in combination with Ra ≤ 32 µin, Ra ≤ 16 µin (order code for "Measuring tube material", option SB, SC)

<b>½"-Tri-Clamp: 1.4404 (316/316L) (order code for "Process connection", option FDW)</b>				
DN [in]	Clamp [in]	A [in]	B [in]	L [in]
¾	½	0.98	0.37	9.02
½	½	0.98	0.37	10.75

3A version available (order code for "Additional approval", option LP) in combination with Ra ≤ 32 µin, Ra ≤ 16 µin (order code for "Measuring tube material", option SB, SC)

SMS 1145 (threaded hygienic connection)

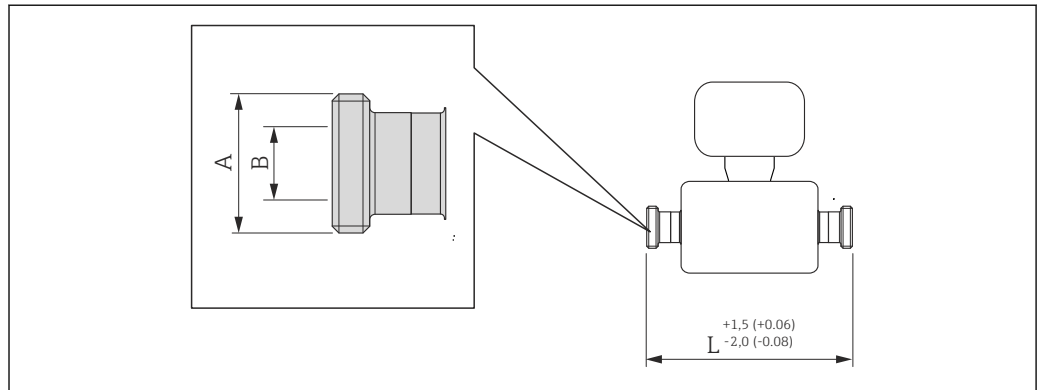

A0015628

45 Engineering unit mm (in)

**Threaded hygienic connection SMS 1145: 1.4404 (316/316L) (order code for "Process connection", option SCS)**

DN [in]	A [in]	B [in]	L [in]
3/8	Rd 40 × 1/6	0.89	9.02
1/2	Rd 40 × 1/6	0.89	10.75
1	Rd 40 × 1/6	0.89	12.76
1 1/2	Rd 60 × 1/6	1.40	17.95
2	Rd 70 × 1/6	1.91	22.13
3	Rd 98 × 1/6	2.87	26.46

3A version available (order code for "Additional approval", option LP) in combination with Ra ≤ 32 µin (order code for "Measuring tube material", option SB)

**Safety Barrier Promass 100**

Top-hat rail EN 60715:

- TH 35 x 7.5
- TH 35 x 15

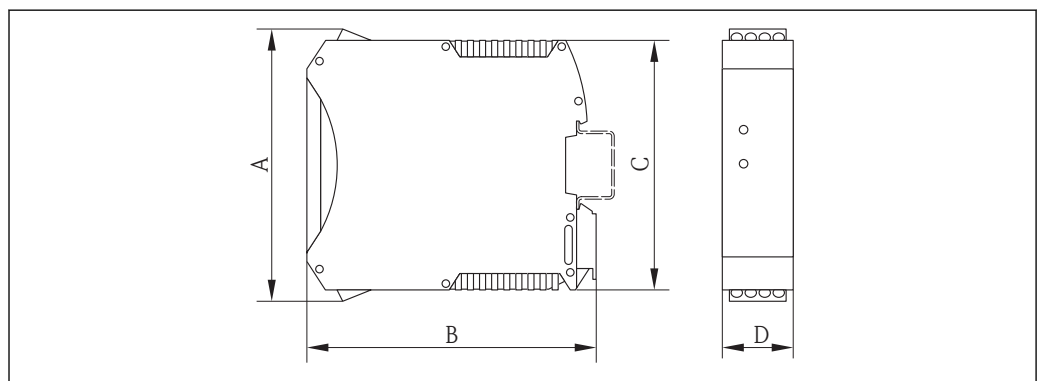

A0016777

A		B		C		D	
[mm]	[in]	[mm]	[in]	[mm]	[in]	[mm]	[in]
108	4.25	114.5	4.51	99	3.9	22.5	0.89



**Weight**

**Compact version**

*Weight in SI units*

All values (weight) refer to devices with EN/DIN PN 40 flanges. Weight information in [kg].

DN [mm]	Weight [kg]
8	6
15	6
25	8
40	13
50	20
80	29

*Weight in US units*

All values (weight) refer to devices with EN/DIN PN 40 flanges. Weight information in [lbs].

DN [in]	Weight [lbs]
$\frac{3}{8}$	13
$\frac{1}{2}$	13
1	18
1 $\frac{1}{2}$	29
2	44
3	64

**Safety Barrier Promass 100**

49 g (1.73 ounce)

**Materials**

**Transmitter housing**

- Order code for "Housing", option **A** "Compact, aluminum coated":  
Aluminum, AlSi10Mg, coated
- Order code for "Housing", option **B** "Compact, hygienic, stainless":  
Hygienic version, stainless steel 1.4301 (304)
- Order code for "Housing", option **C** "Ultra compact, hygienic, stainless":  
Hygienic version, stainless steel 1.4301 (304)

### Cable entries/cable glands

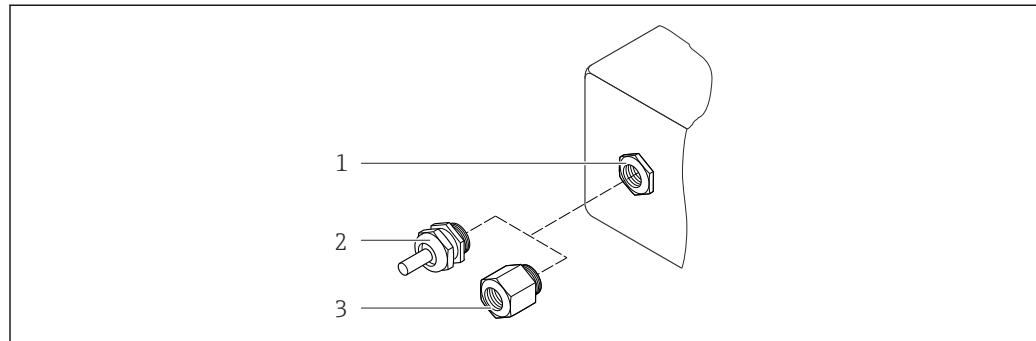

A0020640

#### 46 Possible cable entries/cable glands

- 1 Cable entry in transmitter housing, wall-mount housing or connection housing with internal thread M20 x 1.5
- 2 Cable gland M20 x 1.5
- 3 Adapter for cable entry with internal thread G ½" or NPT ½"

Order code for "Housing", option A "Compact, coated aluminum"

The various cable entries are suitable for hazardous and non-hazardous areas.

Cable entry/cable gland	Material
Cable gland M20 x 1.5	Nickel-plated brass
Adapter for cable entry with internal thread G ½"	
Adapter for cable entry with internal thread NPT ½"	

Order code for "Housing", option B "Compact, hygienic, stainless"

The various cable entries are suitable for hazardous and non-hazardous areas.

Cable entry/cable gland	Material
Cable gland M20 x 1.5	Stainless steel, 1.4404 (316L)
Adapter for cable entry with internal thread G ½"	
Adapter for cable entry with internal thread NPT ½"	

### Device plug

Electrical connection	Material
Plug M12x1	<ul style="list-style-type: none"> <li>▪ Socket: Stainless steel, 1.4404 (316L)</li> <li>▪ Contact housing: Polyamide</li> <li>▪ Contacts: Gold-plated brass</li> </ul>

### Sensor housing

- Acid and alkali-resistant outer surface
- Stainless steel 1.4301 (304)

### Measuring tubes

Stainless steel, 1.4539 (904L); manifold: stainless steel, 1.4404 (316L)

**Surface quality:**

- Not polished
- Ra<sub>max</sub> = 0.8 µm (32 µin)
- Ra<sub>max</sub> = 0.4 µm (16 µin)

**Process connections**

- Flanges according to EN 1092-1 (DIN2501) / according to ASME B 16.5 / as per JIS B2220: Stainless steel, 1.4404 (F316/F316L)
- All other process connections: Stainless steel, 1.4404 (316/316L)



List of all available process connections (→ 67)

**Seals**

Welded process connections without internal seals

**Safety Barrier Promass 100**

Housing: Polyamide

---

**Process connections**

- Flanges:
  - EN 1092-1 (DIN 2501)
  - EN 1092-1 (DIN 2512N)
  - Namur lengths in accordance with NE 132
  - ASME B16.5
  - JIS B2220
- VCO connections
- Tri-Clamp (OD tubes)
- Threaded hygienic connection:
  - DIN 11851
  - SMS 1145
  - ISO 2853
  - DIN 11864-1 Form A
- Flange:
  - DIN 11864-2 Form A



For information on the materials of the process connections (→ 67)

## Operability

---

**Operating concept**

**Operator-oriented menu structure for user-specific tasks**

- Commissioning
- Operation
- Diagnostics
- Expert level

**Quick and safe commissioning**

- Individual menus for applications
- Menu guidance with brief explanations of the individual parameter functions

**Reliable operation**

- Operation in the following languages:
  - Via "FieldCare" operating tool:
    - English, German, French, Spanish, Italian, Chinese, Japanese
  - Via Web browser:
    - English, German, French, Spanish, Italian, Dutch, Portuguese, Polish, Russian, Turkish, Chinese, Japanese, Bahasa (Indonesian), Vietnamese, Czech
- Uniform operating philosophy applied to operating tools and Web browser
- If replacing the electronic module, transfer the device configuration via the plug-in memory (HistoROM DAT) which contains the process and measuring device data and the event logbook. No need to reconfigure.
  - For devices with Modbus RS485, the data recovery function is implemented without the plug-in memory (HistoROM DAT).

**Efficient diagnostics increase measurement availability**

- Troubleshooting measures can be called up via the operating tools and Web browser
- Diverse simulation options
- Status indicated by several light emitting diodes (LEDs) on the electronic module in the housing compartment

**Local display**

The local display is only available with the following device version:  
Order code for "Display; Operation", option **B**: 4-line; via communication

**Display element**

- 4-line liquid crystal display with 16 characters per line.
- White background lighting; switches to red in event of device errors.
- Format for displaying measured variables and status variables can be individually configured.
- Permitted ambient temperature for the display:  $-20$  to  $+60$  °C ( $-4$  to  $+140$  °F). The readability of the display may be impaired at temperatures outside the temperature range.

**Remote operation****Via HART protocol**

This communication interface is present in the following device version:  
Order code for "Output", option **B**: 4-20 mA HART, pulse/frequency/switch output

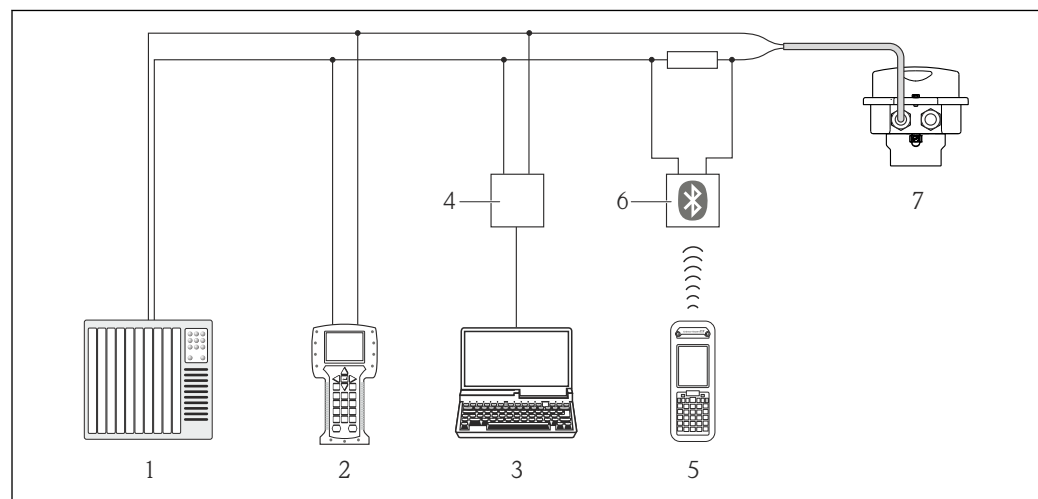

47 Options for remote operation via HART protocol

- 1 Control system (e.g. PLC)
- 2 Field Communicator 475
- 3 Computer with operating tool (e.g. FieldCare, AMS Device Manager, SIMATIC PDM)
- 4 Commubox FXA195 (USB)
- 5 Field Xpert SFX350 or SFX370
- 6 VIATOR Bluetooth modem with connecting cable
- 7 Transmitter

**Via Ethernet-based fieldbus**

This communication interface is present in the following device version:  
Order code for "Output", option **N**: EtherNet/IP

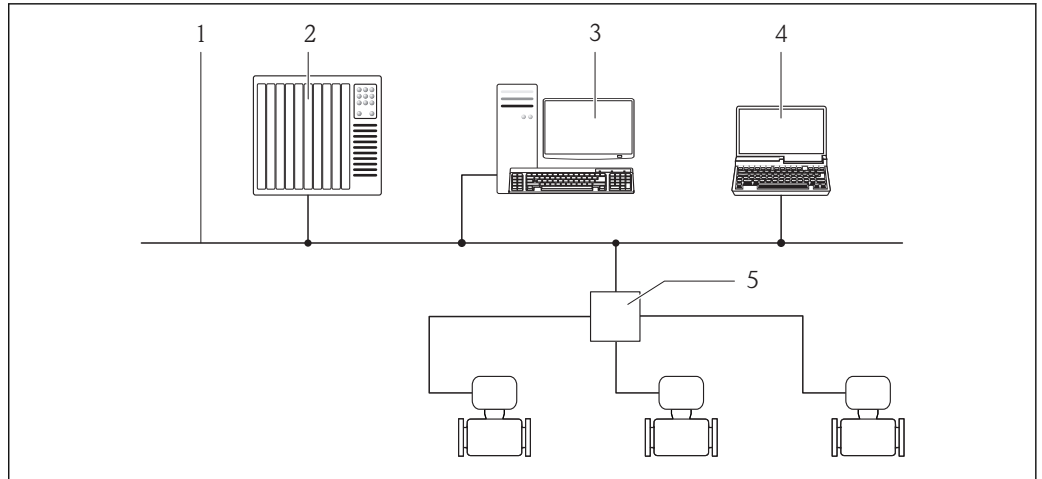

A0016961

- 1 Ethernet network
- 2 Automation system, e.g. "RSLogix" (Rockwell Automation)
- 3 Workstation for measuring device operation: with Add-on Profile Level 3 for "RSLogix 5000" (Rockwell Automation) or with Electronic Data Sheet (EDS)
- 4 Computer with Web browser (e.g. Internet Explorer) for accessing the integrated device Web server or with "FieldCare" operating tool with COM DTM "CDI Communication TCP/IP"
- 5 Ethernet switch

#### Via PROFIBUS DP network

This communication interface is present in the following device version:  
Order code for "Output", option L: PROFIBUS DP

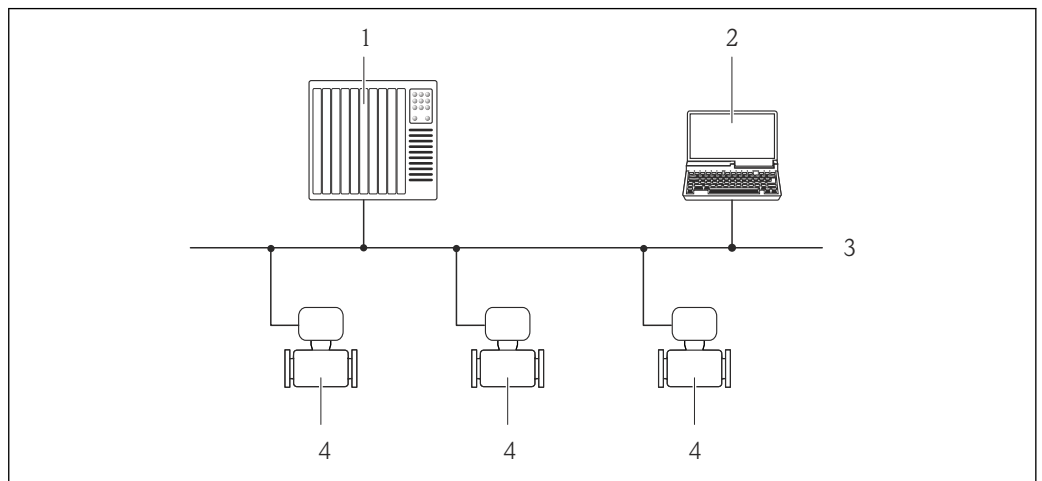

A0020903

- 1 Automation system
- 2 Computer with PROFIBUS network card
- 3 PROFIBUS DP network
- 4 Measuring device

#### Service interface

#### Service interface (CDI-RJ45)

This communication interface is present in the following device version:

- Order code for "Output", option B: 4-20 mA HART, pulse/frequency/switch output
- Order code for "Output", option L: PROFIBUS DP
- Order code for "Output", option N: EtherNet/IP

## HART

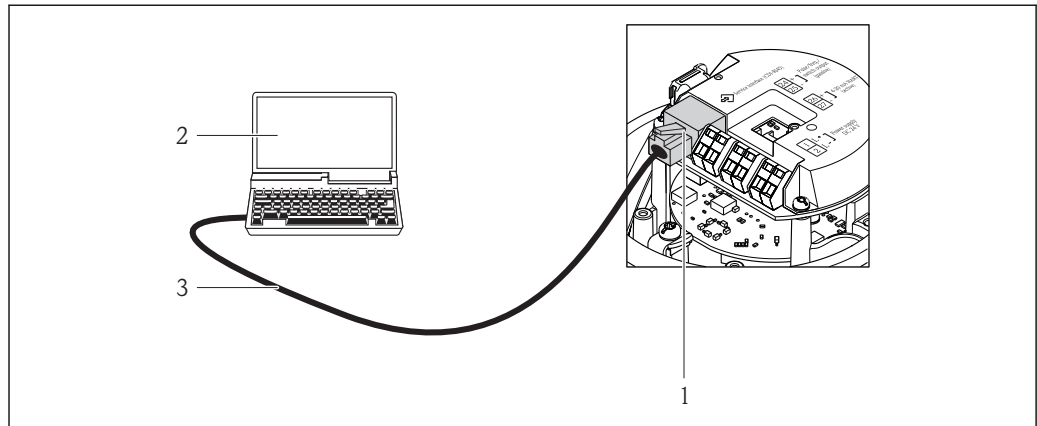

A0016926

▣ 48 Connection for the order code for "Output", option B: 4-20 mA HART, pulse/frequency/switch output

- 1 Service interface (CDI -RJ45) of the measuring device with access to the integrated Web server
- 2 Computer with Web browser (e.g. Internet Explorer) for accessing the integrated device Web server or with "FieldCare" operating tool with COM DTM "CDI Communication TCP/IP"
- 3 Standard Ethernet connecting cable with RJ45 plug

## PROFIBUS DP

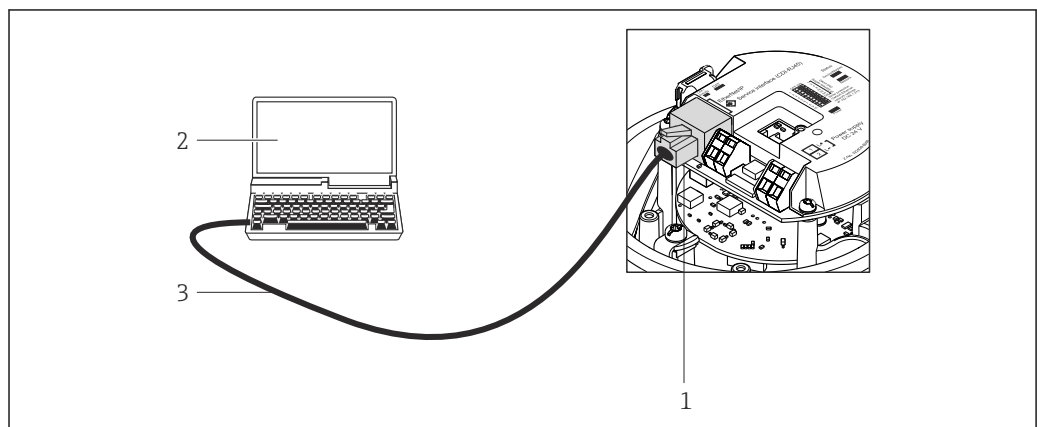

A0021270

▣ 49 Connection for order code for "Output", option L: PROFIBUS DP

- 1 Service interface (CDI -RJ45) of the measuring device with access to the integrated Web server
- 2 Computer with Web browser (e.g. Internet Explorer) for accessing the integrated device Web server or with "FieldCare" operating tool with COM DTM "CDI Communication TCP/IP"
- 3 Standard Ethernet connecting cable with RJ45 plug

EtherNet/IP

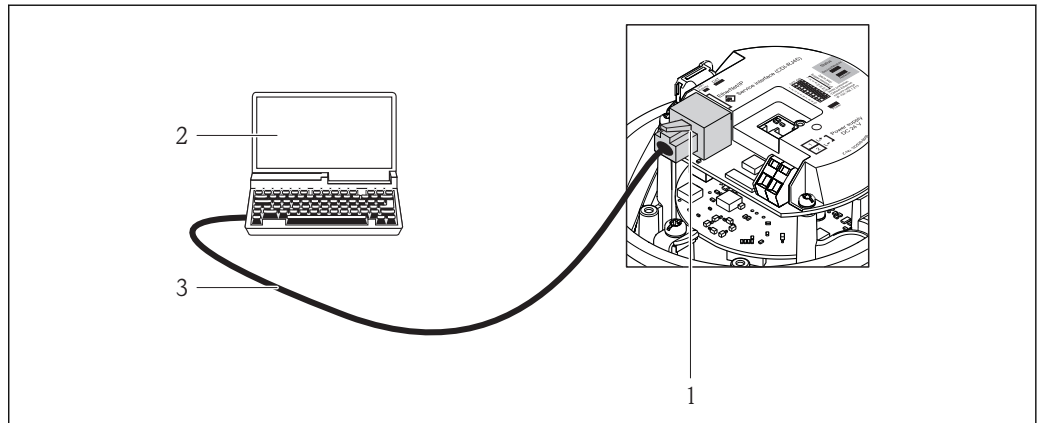

A0016940

50 Connection for order code for "Output", option N: EtherNet/IP

- 1 Service interface (CDI -RJ45) and EtherNet/IP interface of the measuring device with access to the integrated Web server
- 2 Computer with Web browser (e.g. Internet Explorer) for accessing the integrated device Web server or with "FieldCare" operating tool with COM DTM "CDI Communication TCP/IP"
- 3 Standard Ethernet connecting cable with RJ45 plug

Service interface (CDI)

This communication interface is present in the following device version:  
 Order code for "Output", option **M**: Modbus RS485

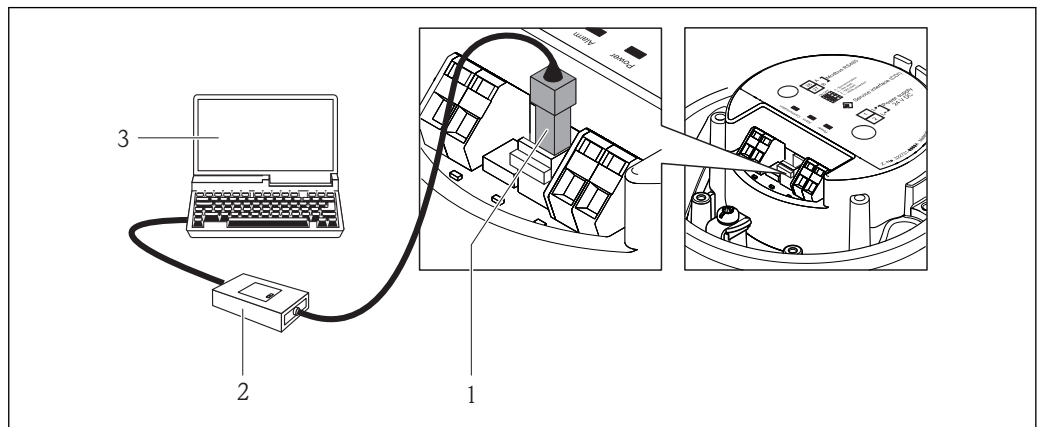

A0016925

- 1 Service interface (CDI) of the measuring device
- 2 Commubox FXA291
- 3 Computer with "FieldCare" operating tool with COM DTM "CDI Communication FXA291"

## Certificates and approvals

**CE mark**

The measuring system is in conformity with the statutory requirements of the applicable EC Directives. These are listed in the corresponding EC Declaration of Conformity along with the standards applied.

Endress+Hauser confirms successful testing of the device by affixing to it the CE mark.

**C-Tick symbol**

The measuring system meets the EMC requirements of the "Australian Communications and Media Authority (ACMA)".

**Ex approval**

The measuring device is certified for use in hazardous areas and the relevant safety instructions are provided in the separate "Safety Instructions" (XA) document. Reference is made to this document on the nameplate.

 The separate Ex documentation (XA) containing all the relevant explosion protection data is available from your Endress+Hauser sales center.

**ATEX/IECEX**

Currently, the following versions for use in hazardous areas are available:

*Ex ia*

Category (ATEX)	Type of protection
II2G	Ex ia IIC T6...T1 Gb
II2G	Ex ia IIC T6...T1 Gb or Ex ia IIB T6...T1 Gb
II1/2G, II2D	Ex ia IIC T6...T1 Ga/Gb or Ex ia IIB T6...T1 Ga/Gb Ex tb IIIC Txxx Db
II2G, II2D	Ex ia IIC T6...T1 Gb or Ex ia IIB T6...T1 Gb Ex tb IIIC Txxx Db

*Ex nA*

Category (ATEX)	Type of protection
II3G	Ex nA IIC T6...T1 Gc or Ex nA IIC T5-T1 Gc

**cCSA<sub>US</sub>**

Currently, the following versions for use in hazardous areas are available:

*IS (Ex i)*

- Class I Division 1 Groups ABCD
- Class II Division 1 Groups EFG and Class III

*NI (Ex nA)*

Class I Division 2 Groups ABCD

**Hygienic compatibility**

3A approval

**Certification PROFIBUS****PROFIBUS interface**

The measuring device is certified and registered by the PROFIBUS User Organization (PNO). The measuring system meets all the requirements of the following specifications:

- Certified in accordance with PROFIBUS PA Profile 3.02
- The device can also be operated with certified devices of other manufacturers (interoperability)

**Modbus RS485 certification**

The measuring device meets all the requirements of the MODBUS/TCP conformity test and has the "MODBUS/TCP Conformance Test Policy, Version 2.0". The measuring device has successfully passed all the test procedures carried out and is certified by the "MODBUS/TCP Conformance Test Laboratory" of the University of Michigan.

**EtherNet/IP certification**

The measuring device is certified and registered by the ODVA (Open Device Vendor Association). The measuring system meets all the requirements of the following specifications:

- Certified in accordance with the ODVA Conformance Test
- EtherNet/IP Performance Test
- EtherNet/IP PlugFest compliance
- The device can also be operated with certified devices of other manufacturers (interoperability)

**Pressure Equipment Directive**

The devices can be ordered with or without a PED approval. If a device with a PED approval is required, this must be explicitly stated in the order. For devices with nominal diameters less than or equal to DN 25 (1"), this is neither possible nor necessary.



- With the PED/G1/x (x = category) marking on the sensor nameplate, Endress+Hauser confirms compliance with the "Essential Safety Requirements" specified in Annex I of the Pressure Equipment Directive 97/23/EC.
- Devices bearing this marking (PED) are suitable for the following types of medium:
  - Media in Group 1 and 2 with a vapor pressure greater than, or smaller and equal to 0.5 bar (7.3 psi)
  - Unstable gases
- Devices not bearing this marking (PED) are designed and manufactured according to good engineering practice. They meet the requirements of Art.3 Section 3 of the Pressure Equipment Directive 97/23/EC. The range of application is indicated in tables 6 to 9 in Annex II of the Pressure Equipment Directive.

---

**Other standards and guidelines**

- EN 60529  
Degrees of protection provided by enclosures (IP code)
- IEC/EN 60068-2-6  
Environmental influences: Test procedure - Test Fc: vibrate (sinusoidal).
- IEC/EN 60068-2-31  
Environmental influences: Test procedure - Test Ec: shocks due to rough handling, primarily for devices.
- EN 61010-1  
Safety requirements for electrical equipment for measurement, control and laboratory use
- IEC/EN 61326  
Emission in accordance with Class A requirements. Electromagnetic compatibility (EMC requirements).
- NAMUR NE 21  
Electromagnetic compatibility (EMC) of industrial process and laboratory control equipment
- NAMUR NE 32  
Data retention in the event of a power failure in field and control instruments with microprocessors
- NAMUR NE 43  
Standardization of the signal level for the breakdown information of digital transmitters with analog output signal.
- NAMUR NE 53  
Software of field devices and signal-processing devices with digital electronics
- NAMUR NE 80  
The application of the pressure equipment directive to process control devices
- NAMUR NE 105  
Specifications for integrating fieldbus devices in engineering tools for field devices
- NAMUR NE 107  
Self-monitoring and diagnosis of field devices
- NAMUR NE 131  
Requirements for field devices for standard applications
- NAMUR NE 132  
Coriolis mass meter

## Ordering information

Detailed ordering information is available from the following sources:

- In the Product Configurator on the Endress+Hauser website: [www.endress.com](http://www.endress.com) → Select country → Instruments → Select device → Product page function: Configure this product
- From your Endress+Hauser Sales Center: [www.endress.com/worldwide](http://www.endress.com/worldwide)

**Product Configurator - the tool for individual product configuration**

- Up-to-the-minute configuration data
- Depending on the device: Direct input of measuring point-specific information such as measuring range or operating language
- Automatic verification of exclusion criteria
- Automatic creation of the order code and its breakdown in PDF or Excel output format
- Ability to order directly in the Endress+Hauser Online Shop

## Application packages

Many different application packages are available to enhance the functionality of the device. Such packages might be needed to address safety aspects or specific application requirements.

The application packages can be ordered from Endress+Hauser either directly with the device or subsequently. Detailed information on the order code in question is available from your local Endress+Hauser sales center or on the product page of the Endress+Hauser website: [www.endress.com](http://www.endress.com).

Heartbeat Technology	Package	Description
	Heartbeat Verification +Monitoring	<p><b>Heartbeat Monitoring:</b> Continuously supplies monitoring data, which are characteristic of the measuring principle, for an external condition monitoring system. This makes it possible to:</p> <ul style="list-style-type: none"> <li>▪ Draw conclusions - using these data and other information - about the impact the measuring application has on the measuring performance over time.</li> <li>▪ Schedule servicing in time.</li> <li>▪ Monitor the product quality, e.g. gas pockets.</li> </ul> <p><b>Heartbeat Verification:</b> Makes it possible to check the device functionality on demand when the device is installed, without having to interrupt the process.</p> <ul style="list-style-type: none"> <li>▪ Access via onsite operation or other operating interfaces, such as FieldCare for instance.</li> <li>▪ Documentation of device functionality within the framework of manufacturer specifications, for proof testing for instance.</li> <li>▪ End-to-end, traceable documentation of the verification results, including report.</li> <li>▪ Makes it possible to extend calibration intervals in accordance with operator's risk assessment.</li> </ul>







Concentration	Package	Description
	Concentration measurement and special density	<p><b>Calculation and outputting of fluid concentrations</b> Many applications use density as a key measured value for monitoring quality or controlling processes. The device measures the density of the fluid as standard and makes this value available to the control system. The "Special Density" application package offers high-precision density measurement over a wide density and temperature range particularly for applications subject to varying process conditions.</p> <p>With the help of the "Concentration Measurement" application package, the measured density is used to calculate other process parameters:</p> <ul style="list-style-type: none"> <li>▪ Temperature-compensated density (reference density).</li> <li>▪ Percentage mass of the individual substances in a two-phase fluid. (Concentration in %).</li> <li>▪ Fluid concentration is output with special units (°Brix, °Baumé, °API, etc.) for standard applications.</li> </ul> <p>The measured values are output via the digital and analog outputs of the device.</p>

## Accessories

Various accessories, which can be ordered with the device or subsequently from Endress+Hauser, are available for the device. Detailed information on the order code in question is available from your local Endress+Hauser sales center or on the product page of the Endress+Hauser website: [www.endress.com](http://www.endress.com).



Device-specific accessories	For the sensor	
Accessories	Description	
Heating jacket	<p>Is used to stabilize the temperature of the fluids in the sensor. Water, water vapor and other non-corrosive liquids are permitted for use as fluids. If using oil as a heating medium, please consult with Endress+Hauser. Heating jackets cannot be used with sensors fitted with a rupture disk.</p> <p> For details, see Operating Instructions BA00099D</p>	

**Communication-specific accessories**



Accessories	Description
Commubox FXA195 HART	For intrinsically safe HART communication with FieldCare via the USB interface.  For details, see "Technical Information" TI00404F
HART Loop Converter HMX50	Is used to evaluate and convert dynamic HART process variables to analog current signals or limit values.  For details, see "Technical Information" TI00429F and Operating Instructions BA00371F
Wireless HART adapter SWA70	Is used for the wireless connection of field devices. The WirelessHART adapter can be easily integrated into field devices and existing infrastructures, offers data protection and transmission safety and can be operated in parallel with other wireless networks with minimum cabling complexity.  For details, see Operating Instructions BA00061S
Fieldgate FXA320	Gateway for the remote monitoring of connected 4-20 mA measuring devices via a Web browser.  For details, see "Technical Information" TI00025S and Operating Instructions BA00053S
Fieldgate FXA520	Gateway for the remote diagnostics and remote configuration of connected HART measuring devices via a Web browser.  For details, see "Technical Information" TI00025S and Operating Instructions BA00051S
Field Xpert SFX350	Field Xpert SFX350 is a mobile computer for commissioning and maintenance. It enables efficient device configuration and diagnostics for HART and FOUNDATION Fieldbus devices in the <b>non-Ex area</b> .  For details, see Operating Instructions BA01202S
Field Xpert SFX370	Field Xpert SFX370 is a mobile computer for commissioning and maintenance. It enables efficient device configuration and diagnostics for HART and FOUNDATION Fieldbus devices in the <b>non-Ex area</b> and the <b>Ex area</b> .  For details, see Operating Instructions BA01202S

**Service-specific accessories**

Accessories	Description
Applicator	Software for selecting and sizing Endress+Hauser measuring devices: <ul style="list-style-type: none"> <li>Calculation of all the necessary data for identifying the optimum flowmeter: e.g. nominal diameter, pressure loss, accuracy or process connections.</li> <li>Graphic illustration of the calculation results</li> </ul> Administration, documentation and access to all project-related data and parameters over the entire life cycle of a project. Applicator is available: <ul style="list-style-type: none"> <li>Via the Internet: <a href="https://wapps.endress.com/applicator">https://wapps.endress.com/applicator</a></li> <li>On CD-ROM for local PC installation.</li> </ul>
W@M	Life cycle management for your plant W@M supports you with a wide range of software applications over the entire process: from planning and procurement, to the installation, commissioning and operation of the measuring devices. All the relevant device information, such as the device status, spare parts and device-specific documentation, is available for every device over the entire life cycle. The application already contains the data of your Endress+Hauser device. Endress+Hauser also takes care of maintaining and updating the data records. W@M is available: <ul style="list-style-type: none"> <li>Via the Internet: <a href="http://www.endress.com/lifecyclemanagement">www.endress.com/lifecyclemanagement</a></li> <li>On CD-ROM for local PC installation.</li> </ul>

FieldCare	FDT-based plant asset management tool from Endress+Hauser. It can configure all smart field units in your system and helps you manage them. By using the status information, it is also a simple but effective way of checking their status and condition.  For details, see Operating Instructions BA00027S and BA00059S
Commubox FXA291	Connects Endress+Hauser field devices with a CDI interface (= Endress+Hauser Common Data Interface) and the USB port of a computer or laptop.  For details, see "Technical Information" TI00405C

**System components**

Accessories	Description
Memograph M graphic display recorder	The Memograph M graphic display recorder provides information on all relevant measured variables. Measured values are recorded correctly, limit values are monitored and measuring points analyzed. The data are stored in the 256 MB internal memory and also on a SD card or USB stick.  For details, see "Technical Information" TI00133R and Operating Instructions BA00247R
iTEMP	The temperature transmitters can be used in all applications and are suitable for the measurement of gases, steam and liquids. They can be used to read in the fluid temperature.  For details, see "Fields of Activity", FA00006T

## Documentation

-  For an overview of the scope of the associated Technical Documentation, refer to the following:
- The CD-ROM provided for the device (depending on the device version, the CD-ROM might not be part of the delivery!)
  - The *W@M Device Viewer* : Enter the serial number from the nameplate ([www.endress.com/deviceviewer](http://www.endress.com/deviceviewer))
  - The *Endress+Hauser Operations App*: Enter the serial number from the nameplate or scan the 2-D matrix code (QR code) on the nameplate.

**Standard documentation**

**Brief Operating Instructions**

Measuring device	Documentation code
Promass E 100	KA01115D

**Operating Instructions**

Measuring device	Documentation code			
	HART	PROFIBUS DP	Modbus RS485	EtherNet/IP
Promass E 100	BA01167D	BA01248D	BA01056D	BA01064D

**Supplementary device-dependent documentation**

**Safety Instructions**

Contents	Documentation code
ATEX/IECEX Ex i	XA00159D
ATEX/IECEX Ex nA	XA01029D
cCSAus IS	XA00160D
INMETRO Ex i	XA01219D
INMETRO Ex nA	XA01220D

Contents	Documentation code
NEPSI Ex i	XA01249D
NEPSI Ex nA	XA01262D

### Special Documentation

Contents	Documentation code
Information on the Pressure Equipment Directive	SD00142D
Modbus RS485 Register Information	SD00154D
Concentration Measurement	SD01152D
Heartbeat Technology	SD01153D

### Installation Instructions

Contents	Documentation code
Installation Instructions for spare part sets	Specified for each individual accessory (→  74)

## Registered trademarks

### HART®

Registered trademark of the HART Communication Foundation, Austin, USA

### PROFIBUS®

Registered trademark of the PROFIBUS User Organization, Karlsruhe, Germany

### Modbus®

Registered trademark of SCHNEIDER AUTOMATION, INC.

### EtherNet/IP™

Trademark of ODVA, Inc.

### Microsoft®

Registered trademark of the Microsoft Corporation, Redmond, Washington, USA

### TRI-CLAMP®

Registered trademark of Ladish & Co., Inc., Kenosha, USA

### Applicator®, FieldCare®, Field Xpert™, HistoROM®, Heartbeat Technology™

Registered or registration-pending trademarks of the Endress+Hauser Group

---

---

[www.addresses.endress.com](http://www.addresses.endress.com)

---