

## Technical Information

# Proline Promass 80P, 83P

## Coriolis Mass Flow Measuring System

The single-tube system with a "fit-and-forget" design:  
hygienic – drainable – complying with the requirements, codes  
and standards ASME BPE, ISPE, FDA, EHEDG, 3-A



### Application

The Coriolis measuring principle operates independently of physical fluid properties, such as viscosity and density.

- Extremely accurate measurement of liquids and gases found in Life Sciences Industries processes such as: Water purification, WFI, Fermentation processes, Media preparation, batch verification, batch fermenter, Sterilization process, cleaning agents and solvents. Fast recovery from CIP/SIP.
- Process up to +200 °C and 63 bar
- Mass flow measurement up to 70 t/h

Certification for highly regulated industries:

- ASME BPE Certificate of Compliance to relevant scope, 3A, EHEDG
- Inspection certificates: EN 10204, MTR for material, roughness, and delta ferrite.

Approvals for:

- ATEX, FM, CSA, TIIS, IECEx, NEPSI
- HART, PROFIBUS PA/DP, FOUNDATION Fieldbus, MODBUS
- Pressure Equipment Directive, SIL-2

### Your benefits

The Promass measuring devices are suitable for use in PAT applications for the continuous monitoring of critical quality process variables such as mass flow, volume flow, density and temperature.

The uniform **Proline transmitter concept** includes software options for batching and concentration measurement for extended range of application.

The **Promass sensors**, tried and tested in over 100 000 applications, offer:

- Material selected according to ASME BPE and BN2 guidelines, EN 1.4435/ASTM 316L, low delta ferrite
- Wetted surfaces:  $Ra_{max} = 0.76 \mu\text{m}$  or  $Ra_{max} = 0.38 \mu\text{m}$  electropolished
- Accredited flow calibration according to ISO/SCS/IEC 17025/A2LA, traceable density calibration
- Fully welded sensor design, no seals or gaskets
- Electropolished exterior: "Hygienic design" for higher corrosion resistance and easier cleanability
- Complete drainability, even in horizontal lines

## Table of contents

<b>Function and system design</b> .....	<b>3</b>	<b>Mechanical construction</b> .....	<b>22</b>
Measuring principle .....	3	Design / dimensions .....	22
Measuring system .....	4	Weight .....	36
<b>Input</b> .....	<b>6</b>	Materials .....	36
Measured variable .....	6	Material load curves .....	37
Measuring range .....	6	Process connections .....	38
Operable flow range .....	6	<b>Human interface</b> .....	<b>39</b>
Input signal .....	6	Display elements .....	39
<b>Output</b> .....	<b>7</b>	Unified control concept for both types of transmitter .....	39
Output signal .....	7	Language groups .....	39
Signal on alarm .....	9	Remote operation .....	39
Load .....	9	<b>Certificates and approvals</b> .....	<b>39</b>
Low flow cut off .....	9	CE mark .....	39
Galvanic isolation .....	9	C-Tick symbol .....	39
Switching output .....	9	Ex approval .....	39
<b>Power supply</b> .....	<b>10</b>	Hygienic compatibility .....	39
Electrical connection Measuring unit .....	10	Flow calibration .....	40
Electrical connection, terminal assignment .....	11	TSE compliance .....	40
Electrical connection Remote version .....	12	Additional test and Inspections .....	40
Supply voltage .....	12	FOUNDATION Fieldbus	
Cable entries .....	13	certification .....	40
Cable specification		PROFIBUS DP/PA certification .....	40
Remote version .....	13	MODBUS certification .....	40
Power consumption .....	13	Other standards and guidelines .....	41
Power supply failure .....	13	Pressure Equipment Directive .....	41
Potential equalization .....	13	Functional safety .....	41
<b>Performance characteristics</b> .....	<b>13</b>	<b>Ordering information</b> .....	<b>41</b>
Reference operating conditions .....	13	<b>Accessories</b> .....	<b>41</b>
Maximum measured error .....	13	<b>Documentation</b> .....	<b>42</b>
Repeatability .....	15	<b>Registered trademarks</b> .....	<b>42</b>
Influence of fluid temperature .....	15		
Influence of fluid pressure .....	15		
<b>Operating conditions: Installation</b> .....	<b>16</b>		
Installation instructions .....	16		
Inlet and outlet runs .....	19		
Length of connecting cable .....	19		
System pressure .....	19		
<b>Operating conditions: Environment</b> .....	<b>20</b>		
Ambient temperature range .....	20		
Storage temperature .....	20		
Degree of protection .....	20		
Shock resistance .....	20		
Vibration resistance .....	20		
Electromagnetic compatibility (EMC) .....	20		
<b>Operating conditions: Process</b> .....	<b>20</b>		
Fluid temperature range .....	20		
Fluid pressure range (nominal pressure) .....	20		
Limiting flow .....	20		
Pressure loss .....	21		

## Function and system design

### Measuring principle

The measuring principle is based on the controlled generation of Coriolis forces. These forces are always present when both translational and rotational movements are superimposed.

$$F_C = 2 \cdot \Delta m (v \cdot \omega)$$

$F_C$  = Coriolis force

$\Delta m$  = moving mass

$\omega$  = rotational velocity

$v$  = radial velocity in rotating or oscillating system

The amplitude of the Coriolis force depends on the moving mass  $\Delta m$ , its velocity  $v$  in the system, and thus on the mass flow. Instead of a constant angular velocity  $\omega$ , the Promass sensor uses oscillation.

This causes the tube through which the fluid is flowing to oscillate. The Coriolis forces produced at the measuring tubes cause a phase shift in the tube oscillations (see illustration):

- If there is zero flow, i.e. when the fluid stands still, the oscillation measured at points A and B has the same phase, and thus there is no phase difference (1).
- Mass flow causes deceleration of the oscillation at the inlet of the tubes (2) and acceleration at the outlet (3).

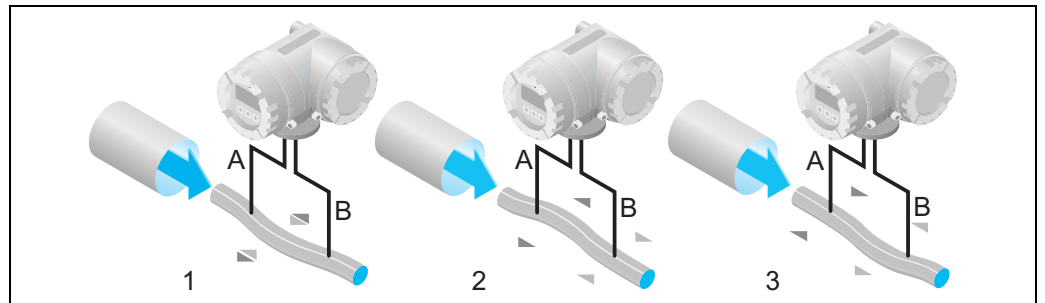

The phase difference (A-B) increases with increasing mass flow. Electrodynamic sensors register the tube oscillations at the inlet and outlet.

The system balance required for proper measurement is created by exciting an eccentrically arranged swinging mass to antiphase oscillation. This patented TMB™ system (Torsion Mode Balanced System) guarantees perfect measurements, even in changing process and environmental conditions.

Therefore, the device is just as easy to install as the familiar two-tube systems! Consequently, no special measures for attachment are required in front of or behind the sensor.

The measuring principle operates independently of temperature, pressure, viscosity, conductivity and flow profile.

### Density measurement

The measuring tube is continuously excited at its resonance frequency. A change in the mass and thus the density of the oscillating system (comprising the measuring tube and fluid) results in a corresponding, automatic adjustment in the oscillation frequency. Resonance frequency is thus a function of fluid density. The microprocessor utilizes this relationship to obtain a density signal.

### Temperature measurement

The temperature of the measuring tube is determined in order to calculate the compensation factor due to temperature effects. This signal corresponds to the process temperature and is also available as an output.

**Measuring system**

The measuring system consists of a transmitter and a sensor. Two versions are available:

- Compact version: transmitter and sensor form a mechanical unit.
- Remote version: transmitter and sensor are mounted physically separate from one another.

**Transmitter**

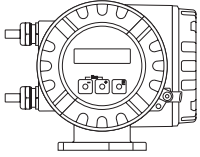
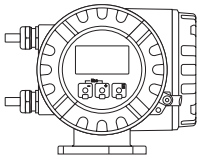
<p><b>Promass 80</b></p>  <p style="text-align: right; font-size: small;">a0003671</p>	<ul style="list-style-type: none"> <li>■ Two-line liquid-crystal display</li> <li>■ Operation with push buttons</li> </ul>
<p><b>Promass 83</b></p>  <p style="text-align: right; font-size: small;">a0003672</p>	<ul style="list-style-type: none"> <li>■ Four-line liquid-crystal display</li> <li>■ Operation with "Touch control"</li> <li>■ Application-specific Quick Setup</li> <li>■ Mass flow, volume flow, density and temperature measurement as well as calculated variables (e.g. fluid concentrations)</li> </ul>

**Sensor**

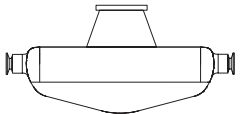
<p><b>P</b></p>  <p style="text-align: right; font-size: small;">a0006828</p>	<ul style="list-style-type: none"> <li>■ Single bent tube, minimal shear stress on fluid. Hygienic design with documents for Life Science Industries applications, low pressure loss, for fluid temperatures up to 200 °C</li> <li>■ Nominal diameters DN 8 to 50</li> <li>■ Material: Stainless Steel EN 1.4435/ ASTM 316L</li> </ul>	<p>Documentation No. TI 078D/06/en</p>
--	--	--

**Other sensors can be found in the separate documentation**

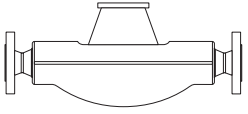
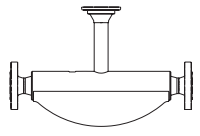
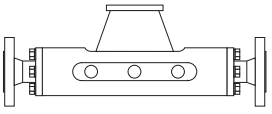
<p><b>F</b></p>  <p style="text-align: right; font-size: small;">a0003673</p>	<ul style="list-style-type: none"> <li>■ Universal sensor for fluid temperatures up to 200 °C.</li> <li>■ Nominal diameters DN 8 to 250</li> <li>■ Material: Stainless Steel EN 1.4539 / ASTM 904L and EN 1.4404 and ASTM 316L or Alloy C-22 DIN 2.4602</li> </ul>	<p>Documentation No. TI 053D/06/en</p>
<p><b>F (High-temperature)</b></p>  <p style="text-align: right; font-size: small;">a0003675</p>	<ul style="list-style-type: none"> <li>■ Universal high-temperature sensor for fluid temperatures up to 350 °C.</li> <li>■ Nominal diameters DN 25, 50, 80</li> <li>■ Material: Alloy C-22, DIN 2.4602</li> </ul>	
<p><b>M</b></p>  <p style="text-align: right; font-size: small;">a0003676</p>	<ul style="list-style-type: none"> <li>■ Robust sensor for extreme process pressures, high requirements for the secondary containment and fluid temperatures up to 150 °C</li> <li>■ Nominal diameters DN 8 to 80</li> <li>■ Material: titanium, Ti, Ti Grade 2, Ti Grade 9</li> </ul>	

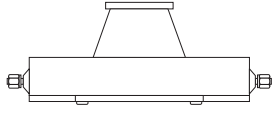
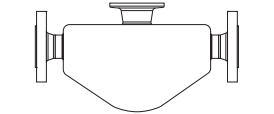
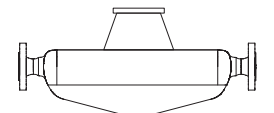
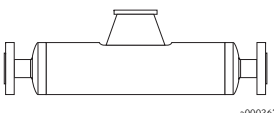
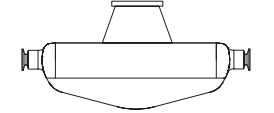
<p><b>A</b></p>  <p>a0003679</p>	<ul style="list-style-type: none"> <li>■ Single-tube system for highly accurate measurement of very small flows</li> <li>■ Nominal diameters DN 1 to 4</li> <li>■ Material: Stainless Steel or EN 1.4539 / ASTM 904L or Alloy C-22 DIN 2.4602</li> </ul>	<p>Documentation No. TI 054D/06/en</p>
<p><b>E</b></p>  <p>a0002271</p>	<ul style="list-style-type: none"> <li>■ General purpose sensor, ideal replacement for volumetric flowmeters.</li> <li>■ Nominal diameters DN 8 to 50</li> <li>■ Material: Stainless Steel EN 1.4539 / ASTM 904L and EN 1.4404 / ASTM 316L</li> </ul>	<p>Documentation No. TI 061D/06/en</p>
<p><b>H</b></p>  <p>a0003677</p>	<ul style="list-style-type: none"> <li>■ Single bent tube. Low pressure loss and chemically resistant material</li> <li>■ Nominal diameters DN 8 to 50</li> <li>■ Material: zirconium 702/R 60702</li> </ul>	<p>Documentation No. TI 074D/06/en</p>
<p><b>I</b></p>  <p>a0003678</p>	<ul style="list-style-type: none"> <li>■ Straight single-tube instrument. Minimal shear stress on fluid, hygienic design, low pressure loss</li> <li>■ Nominal diameters DN 8 to 80</li> <li>■ Material: titanium, Ti Grade 2, Ti Grade 9</li> </ul>	<p>Documentation No. TI 075D/06/en</p>
<p><b>S</b></p>  <p>a0006828</p>	<ul style="list-style-type: none"> <li>■ Single bent tube. Hygienic design, low pressure loss, for fluid temperatures up to 150 °C</li> <li>■ Nominal diameters DN 8 to 50</li> <li>■ Material: Stainless Steel, EN 1.4539 / ASTM 904L and EN 1.4435 and ASTM 316L</li> </ul>	<p>Documentation No. TI 076D/06/en</p>

## Input

<b>Measured variable</b>	<ul style="list-style-type: none"> <li>■ Mass flow (proportional to the phase difference between two sensors mounted on the measuring tube to register a phase shift in the oscillation)</li> <li>■ Fluid density (proportional to resonance frequency of the measuring tube)</li> <li>■ Fluid temperature (measured with temperature sensors)</li> </ul>
--------------------------	---

### Measuring range

#### Measuring ranges for liquids

DN	Range for full scale values (liquids) $\dot{m}_{\min(F)}$ to $\dot{m}_{\max(F)}$
8	0 to 2000 kg/h
15	0 to 6500 kg/h
25	0 to 18000 kg/h
40	0 to 45000 kg/h
50	0 to 70000 kg/h

#### Measuring ranges for gases

The full scale values depend on the density of the gas. Use the formula below to calculate the full scale values:

$$m_{\max(G)} = m_{\max(F)} \cdot \rho_{(G)} / 160 \text{ [kg/m}^3\text{]}$$

$$m_{\max(G)} = \text{max. full scale value for gas [kg/h]}$$

$$m_{\max(F)} = \text{max. full scale value for liquid [kg/h]}$$

$$\rho_{(G)} = \text{Gas density in [kg/m}^3\text{] at operating conditions}$$

Here,  $m_{\max(G)}$  can never be greater than  $m_{\max(F)}$

*Calculation example for gas:*

- Sensor type: Promass P, DN 50
- Gas: air with a density of 60.3 kg/m<sup>3</sup> (at 20 °C and 50 bar)
- Measuring range (liquid): 70000 kg/h

Max. possible full scale value:

$$m_{\max(G)} = m_{\max(F)} \cdot \rho_{(G)} : 160 \text{ [kg/m}^3\text{]} = 70000 \text{ kg/h} \cdot 60.3 \text{ kg/h} : 160 \text{ kg/m}^3 = 26400 \text{ kg/h}$$

*Recommended full scale values*

See information in the "Limiting flow" section → Page 20 ff.

### Operable flow range

Greater than 1000: 1. Flow rates above the preset full scale value do not overload the amplifier, i.e. the totalizer values are registered correctly.

### Input signal

#### Status input (auxiliary input):

U = 3 to 30 V DC, R<sub>i</sub> = 5 kΩ, galvanically isolated.

Configurable for: totalizer reset, positive zero return, error message reset, zero point adjustment start, batching start/stop (optional).

#### Status input (auxiliary input) with PROFIBUS DP and MODBUS RS485:

U = 3 to 30 V DC, R<sub>i</sub> = 3 kΩ, galvanically isolated.

Switching level: 3 to 30 V DC, polarity-independent.

Configurable for: totalizer reset, positive zero return, error message reset, batching start/stop (optional), batch totalizer reset (optional).

#### Current input (only Promass 83)

Active/passive selectable, galvanically isolated, resolution: 2 A

- Active: 4 to 20 mA, R<sub>L</sub> < 700 Ω, U<sub>out</sub> = 24 V DC, short-circuit proof
- Passive: 0/4 to 20 mA, R<sub>i</sub> = 150 Ω, U<sub>max</sub> = 30 V DC

## Output

### Output signal

#### Promass 80

##### *Current output:*

Active/passive selectable, galvanically isolated, time constant selectable (0.05 to 100 s), full scale value selectable, temperature coefficient: typically 0.005% o.f.s./°C, resolution: 0.5 µA

- Active: 0/4 to 20 mA,  $R_L < 700 \Omega$  (for HART:  $R_L \geq 250 \Omega$ )
- Passive: 4 to 20 mA; supply voltage  $U_S$  18 to 30 V DC;  $R_i \geq 150 \Omega$

##### *Pulse/frequency output:*

Passive, open collector, 30 V DC, 250 mA, galvanically isolated.

- Frequency output: full scale frequency 2 to 1000 Hz ( $f_{max} = 1250$  Hz), on/off ratio 1:1, pulse width max. 2 s
- Pulse output: pulse value and pulse polarity selectable, pulse width configurable (0.5 to 2000 ms)

##### *PROFIBUS PA interface:*

- PROFIBUS PA in accordance with EN 50170 Volume 2, IEC 61158-2 (MBP), galvanically isolated
- Profile Version 3.0
- Current consumption: 11 mA
- Permitted supply voltage: 9 to 32 V
- Bus connection with integrated reverse polarity protection
- Error current FDE (Fault Disconnection Electronic) = 0 mA
- Data transmission rate: 31.25 kBit/s
- Signal encoding: Manchester II
- Function blocks: 4 x Analog Input, 1 x Totalizer
- Output data: Mass flow, Volume flow, Density, Temperature, Totalizer
- Input data: Positive zero return (ON/OFF), Zero point adjustment, Measuring mode, Totalizer control
- Bus address can be configured via miniature switches or via the local display (optional)

#### Promass 83

##### *Current output:*

Active/passive selectable, galvanically isolated, time constant selectable (0.05 to 100 s), full scale value selectable, temperature coefficient: typically 0.005% o.f.s./°C, resolution: 0.5 µA

- Active: 0/4 to 20 mA,  $R_L < 700 \Omega$  (for HART:  $R_L \geq 250 \Omega$ )
- Passive: 4 to 20 mA; supply voltage  $U_S$  18 to 30 V DC;  $R_i \geq 150 \Omega$

##### *Pulse/frequency output:*

active/passive selectable, galvanically isolated

- Active: 24 V DC, 25 mA (max. 250 mA during 20 ms),  $R_L > 100 \Omega$
- Passive: open collector, 30 V DC, 250 mA
- Frequency output: full scale frequency 2 to 10000 Hz ( $f_{max} = 12500$  Hz), on/off ratio 1:1, pulse width max. 2 s
- Pulse output: pulse value and pulse polarity selectable, pulse width configurable (0.05 to 2000 ms)

##### *PROFIBUS DP interface:*

- PROFIBUS DP in accordance with EN 50170 Volume 2
- Profile Version 3.0
- Data transmission rate: 9.6 kBaud to 12 MBaud
- Automatic data transmission rate recognition
- Signal encoding: NRZ Code
- Function blocks: 6 x Analog Input, 3 x Totalizer
- Output data: Mass flow, Volume flow, Corrected volume flow, Density, Reference density, Temperature, Totalizers 1 to 3
- Input data: Positive zero return (ON/OFF), Zero point adjustment, Measuring mode, Totalizer control
- Bus address can be configured via miniature switches or via the local display (optional)
- Available output combination → Page 11

*PROFIBUS PA interface:*

- PROFIBUS PA in accordance with EN 50170 Volume 2, IEC 61158-2 (MBP), galvanically isolated
- Data transmission rate:  
31.25 kBit/s
- Current consumption: 11 mA
- Permitted supply voltage: 9 to 32 V
- Bus connection with  
integrated reverse polarity protection
- Error current FDE (Fault Disconnection Electronic): 0 mA
- Signal encoding: Manchester II
- Function blocks: 6 x Analog Input, 3 x Totalizer
- Input data: Positive zero return (ON/OFF), Zero point adjustment, Measuring mode, Totalizer control
- Output data: Mass flow, Volume flow, Corrected volume flow, Density, Reference density, Temperature, Totalizers 1 to 3
- Bus address can be configured via miniature switches or via the local display (optional)
- Available output combination → Page 11

*MODBUS interface:*

- MODBUS device type: slave
- Address range: 1 to 247
- Supported function codes: 03, 04, 06, 08, 16, 23
- Broadcast: supported with the function codes 06, 16, 23
- Physical interface: RS485 in accordance with EIA/TIA-485 standard
- Supported baud rate: 1200, 2400, 4800, 9600, 19200, 38400, 57600, 115200 Baud
- Transmission mode: RTU or ASCII
- Response times:  
Direct data access = typically 25 to 50 ms  
Auto-scan buffer (data range) = typically 3 to 5 ms
- Possible output combinations → Page 11

*FOUNDATION Fieldbus interface:*

- FOUNDATION Fieldbus H1, IEC 61158-2, galvanically isolated
- Data transmission rate: 31.25 kBit/s
- Current consumption: 12 mA
- Permitted supply voltage: 9 to 32 V
- Error current FDE (Fault Disconnection Electronic): 0 mA
- Bus connection with integrated reverse polarity protection
- Signal encoding: Manchester II
- ITK Version 4.01
- Function blocks: 7 x Analog Input, 1 x Digital Output, 1 x PID
- Output data: Mass flow, Volume flow, Corrected volume flow, Density, Reference density, Temperature, Totalizers 1 to 3
- Input data: Positive zero return (ON/OFF), Zero point adjustment, Measuring mode, Reset totalizer
- Link Master (LM) function is supported



---

<b>Signal on alarm</b>	<p><i>Current output:</i> Failsafe mode selectable (e.g. in accordance with NAMUR Recommendation NE 43)</p> <p><i>Pulse/frequency output:</i> Failsafe mode selectable</p> <p><b>Status output (Promass 80):</b> Nonconductive in the event of a fault or if the power supply fails</p> <p><b>Relay output (Promass 83):</b> Dead in the event of a fault or if the power supply fails</p>
<b>Load</b>	see "Output signal"
<b>Low flow cut off</b>	Switch points for low flow cut off are selectable.
<b>Galvanic isolation</b>	All circuits for inputs, outputs, and power supply are galvanically isolated from each other.
<b>Switching output</b>	<p><b>Status output (Promass 80):</b> Open collector, max. 30 V DC / 250 mA, galvanically isolated. Configurable for: error messages, Empty Pipe Detection (EPD), flow direction, limit values.</p> <p><b>Relay output (Promass 83):</b> Normally closed (NC or break) or normally open (NO or make) contacts available (factory setting: relay 1 = NO, relay 2 = NC), max. 30 V / 0.5 A AC; 60 V / 0.1 A DC, galvanically isolated.</p>

---

## Power supply

Electrical connection  
Measuring unit

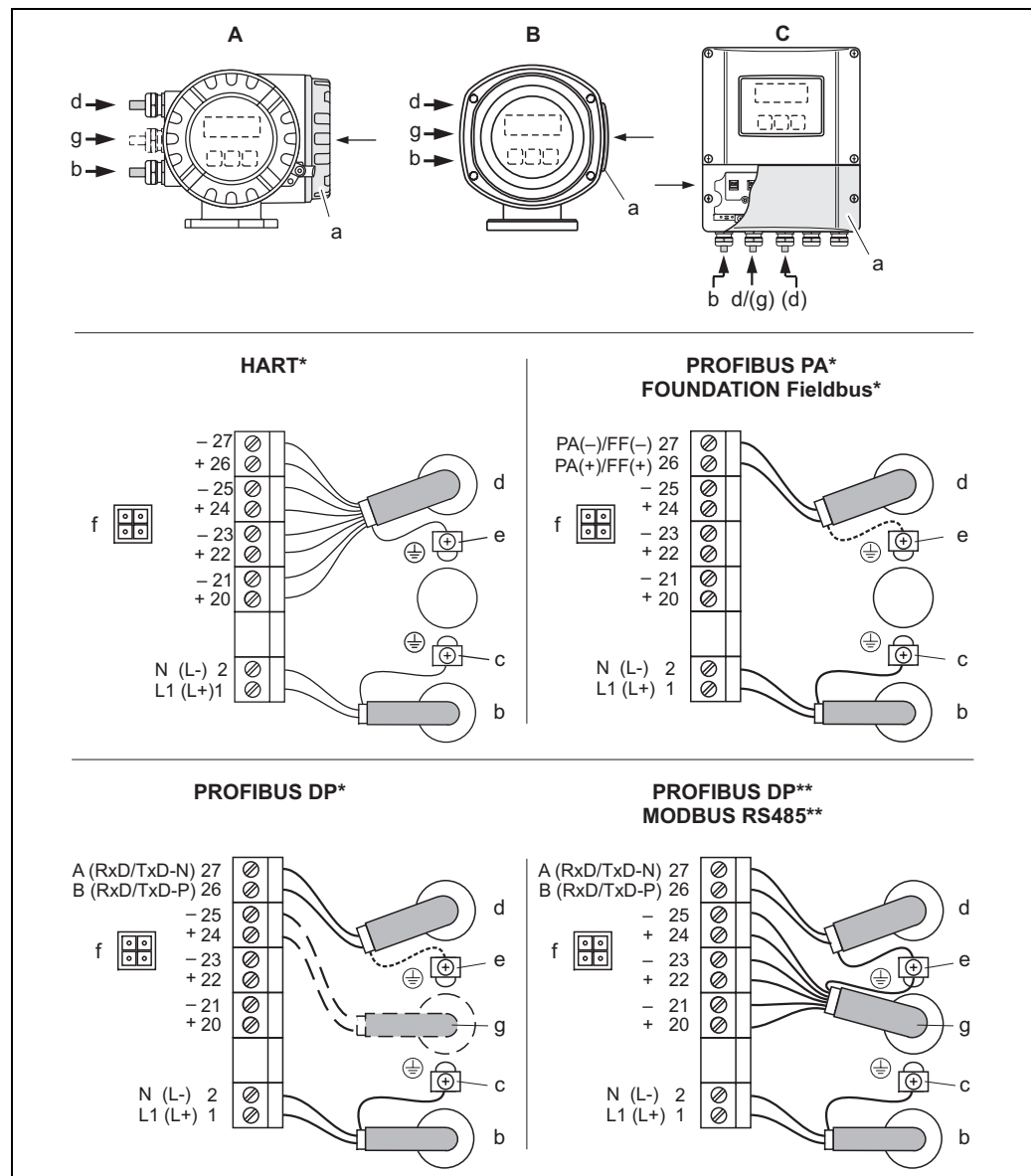

Connecting the transmitter, cable cross-section: max. 2.5 mm<sup>2</sup>

- A View A (field housing)  
B View B (Stainless Steel field housing)  
C View C (wall-mount housing)

\*) fixed communication board

\*\*) flexible communication board

a Connection compartment cover

b Cable for power supply: 85 to 260 V AC, 20 to 55 V AC, 16 to 62 V DC

Terminal No. 1: L1 for AC, L+ for DC

Terminal No. 2: N for AC, L- for DC

c Ground terminal for protective ground

d Signal cable: see Terminal assignment → Page 11

Fieldbus cable:

Terminal No. 26: DP (A) / PA (+) / FF (+) / MODBUS RS485 (A) / (PA, FF: with reverse polarity protection)

Terminal No. 27: DP (B) / PA (-) / FF (-) / MODBUS RS485 (B) / (PA, FF: with reverse polarity protection)

e Ground terminal for signal cable shield / fieldbus cable / RS485 line

f Service adapter for connecting service interface FXA 193 (Fieldcheck, FieldCare)

g Signal cable: see Terminal assignment → Page 11

g Cable for external termination (only for PROFIBUS DP with permanent assignment communication board):

Terminal No. 24: +5 V

Terminal No. 25: DGND

**Electrical connection,  
terminal assignment**

**Promass 80**

Order version	Terminal No. (inputs/outputs)			
	20 (+) / 21 (-)	22 (+) / 23 (-)	24 (+) / 25 (-)	26 (+) / 27 (-)
80***_*****A	-	-	Frequency output	Current output, HART
80***_*****D	Status input	Status output	Frequency output	Current output, HART
80***_*****H	-	-	-	PROFIBUS PA
80***_*****S	-	-	Frequency output Ex i, passive	Current output Ex i Active, HART
80***_*****T	-	-	Frequency output Ex i, passive	Current output Ex i Passive, HART
80***_*****8	Status input	Frequency output	Current output 2	Current output 1, HART

**Promass 83**

The inputs and outputs on the communication board can be either permanently assigned (fixed) or variable (flexible), depending on the version ordered (see table). Replacements for modules which are defective or which have to be replaced can be ordered as accessories.

Order version	Terminal No. (inputs/outputs)			
	20 (+) / 21 (-)	22 (+) / 23 (-)	24 (+) / 25 (-)	26 (+) / 27 (-)
<i>Fixed communication boards (permanent assignment)</i>				
83***_*****A	-	-	Frequency output	Current output HART
83***_*****B	Relay output	Relay output	Frequency output	Current output HART
83***_*****F	-	-	-	PROFIBUS PA, Ex i
83***_*****G	-	-	-	FOUNDATION Fieldbus Ex i
83***_*****H	-	-	-	PROFIBUS PA
83***_*****J	-	-	+5V (ext. termination)	PROFIBUS DP
83***_*****K	-	-	-	FOUNDATION Fieldbus
83***_*****Q	-	-	Status input	MODBUS RS485
83***_*****R	-	-	Current output 2 Ex i, active	Current output 1 Ex i active, HART
83***_*****S	-	-	Frequency output Ex i, passive	Current output Ex i Active, HART
83***_*****T	-	-	Frequency output Ex i, passive	Current output Ex i Passive, HART
83***_*****U	-	-	Current output 2 Ex i, passive	Current output 1 Ex i passive, HART
<i>Flexible communication boards</i>				
83***_*****C	Relay output 2	Relay output 1	Frequency output	Current output HART
83***_*****D	Status input	Relay output	Frequency output	Current output HART
83***_*****E	Status input	Relay output	Current output 2	Current output 1 HART

Order version	Terminal No. (inputs/outputs)			
	20 (+) / 21 (-)	22 (+) / 23 (-)	24 (+) / 25 (-)	26 (+) / 27 (-)
83***_*****L	Status input	Relay output 2	Relay output 1	Current output HART
83***_*****M	Status input	Frequency output 2	Frequency output 1	Current output HART
83***_*****N	Current output	Frequency output	Status input	MODBUS RS485
83***_*****P	Current output	Frequency output	Status input	PROFIBUS DP
83***_*****V	Relay output 2	Relay output 1	Status input	PROFIBUS DP
83***_*****W	Relay output	Current output 3	Current output 2	Current output 1 HART
83***_*****0	Status input	Current output 3	Current output 2	Current output 1 HART
83***_*****2	Relay output	Current output 2	Frequency output	Current output 1 HART
83***_*****3	Current input	Relay output	Current output 2	Current output 1 HART
83***_*****4	Current input	Relay output	Frequency output	Current output HART
83***_*****5	Status input	Current input	Frequency output	Current output HART
83***_*****6	Status input	Current input	Current output 2	Current output HART
83***_*****7	Relay output 2	Relay output 1	Status input	MODBUS RS485

**Electrical connection Remote version**

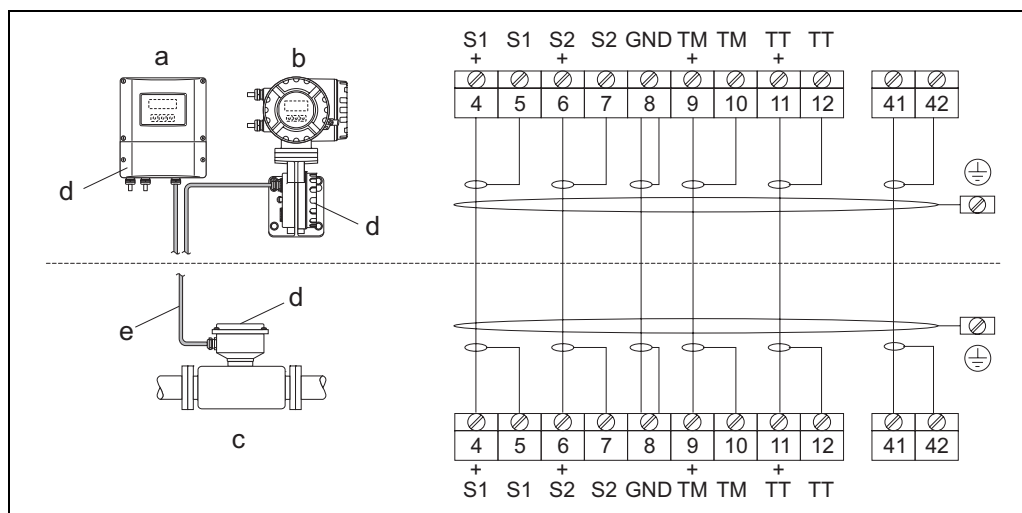

Connecting the remote version

- a Wall-mount housing: non-hazardous area and ATEX II3G / zone 2 → see separate "Ex documentation"
- b Wall-mount housing: ATEX II2G / Zone 1 / FM/CSA → see separate "Ex documentation"
- c Remote version, flanged version
- d Cover for connection compartment or connection housing
- e Connecting cable

Terminal No.: 4/5 = gray; 6/7 = green; 8 = yellow; 9/10 = pink; 11/12 = white; 41/42 = brown

**Supply voltage**

85 to 260 V AC, 45 to 65 Hz  
 20 to 55 V AC, 45 to 65 Hz  
 16 to 62 V DC

<b>Cable entries</b>	<p><i>Power-supply and signal cables (inputs/outputs):</i></p> <ul style="list-style-type: none"> <li>■ Cable entry M20 x 1.5 (8 to 12 mm)</li> <li>■ Thread for cable entries, 1/2" NPT, G 1/2"</li> </ul> <p><i>Connecting cable for remote version:</i></p> <ul style="list-style-type: none"> <li>■ Cable entry M20 x 1.5 (8 to 12 mm)</li> <li>■ Thread for cable entries, 1/2" NPT, G 1/2"</li> </ul>
<b>Cable specification Remote version</b>	<ul style="list-style-type: none"> <li>■ 6 x 0.38 mm<sup>2</sup> (PVC cable with common shield and individually shielded cores)</li> <li>■ Conductor resistance: ≤ 50 Ω/km</li> <li>■ Capacitance: core/shield: ≤ 420 pF/m</li> <li>■ Cable length: max. 20 m</li> <li>■ Permanent operating temperature: max. +105 °C</li> </ul> <p>Operation in zones of severe electrical interference: The measuring device complies with the general safety requirements in accordance with EN 61010, the EMC requirements of EN 61326/A1, and NAMUR recommendation NE 21/43.</p>
<b>Power consumption</b>	<p>AC: &lt;15 VA (including sensor) DC: &lt;15 W (including sensor)</p> <p><i>Switch-on current:</i></p> <ul style="list-style-type: none"> <li>■ Max. 13.5 A (&lt; 50 ms) at 24 V DC</li> <li>■ Max. 3 A (&lt; 5 ms) at 260 V AC</li> </ul>
<b>Power supply failure</b>	<p><b>Promass 80</b></p> <p><i>Lasting min. 1 power cycle:</i></p> <ul style="list-style-type: none"> <li>■ EEPROM saves measuring system data if the power supply fails</li> <li>■ HistoROM/S-DAT: exchangeable data storage chip with sensor specific data (nominal diameter, serial number, calibration factor, zero point, etc.)</li> </ul> <p><b>Promass 83</b></p> <p>Lasting min. 1 power cycle:</p> <ul style="list-style-type: none"> <li>■ EEPROM and T-DAT save the measuring system data if the power supply fails.</li> <li>■ HistoROM/S-DAT: exchangeable data storage chip with sensor specific data (nominal diameter, serial number, calibration factor, zero point, etc.)</li> </ul>
<b>Potential equalization</b>	<p>No measures necessary.</p>

## Performance characteristics

<b>Reference operating conditions</b>	<p><i>Error limits following ISO/DIS 11631:</i></p> <ul style="list-style-type: none"> <li>■ 20 to 30 °C</li> <li>■ 2 to 4 bar</li> <li>■ Calibration systems as per national norms</li> <li>■ Zero point calibrated under operating conditions</li> <li>■ Field density calibrated (or special density calibration)</li> </ul>
<b>Maximum measured error</b>	<p>The following values refer to the pulse/frequency output. Measured error at the current output is typically ±5 A.</p> <p>o.r. = of reading</p> <p><b>Mass flow (liquid):</b></p> <p><i>Promass 80</i></p> <p>±0.15% ± [(zero point stability / measured value) · 100] % o.r.</p> <p><i>Promass 83</i></p> <p>±0.10% ± [(zero point stability / measured value) · 100] % o.r.</p>

**Mass flow (gas)**
 $\pm 0.50\% \pm [(\text{zero point stability} / \text{measured value}) \cdot 100]\% \text{ o.r.}$ 
**Volume flow (liquid)***Promass 80*
 $\pm 0.30\% \pm [(\text{zero point stability} / \text{measured value}) \cdot 100]\% \text{ o.r.}$ 
*Promass 83*
 $\pm 0.25\% \pm [(\text{zero point stability} / \text{measured value}) \cdot 100]\% \text{ o.r.}$ 
**Zero point stability:**

DN	Maximum full scale value [kg/h]	Zero point stability [kg/h]
8	2 000	0.20
15	6 500	0.65
25	18 000	1.8
40	45 000	4.5
50	70 000	7.0

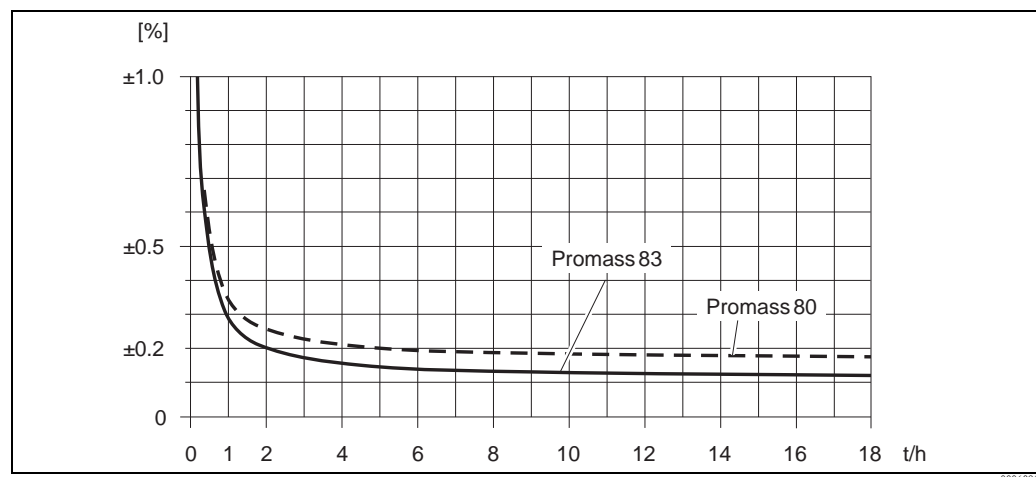
**Sample calculation**

Max. measured error in % of measured value (example: Promass 80P, 83P / DN 25)

Calculation example (mass flow, liquid):

Given: Promass 83P/ DN 25, flow measured value = 8 000 kg/h

Max. measured error:  $\pm 0.10\% \pm [(\text{zero point stability} / \text{measured value}) \cdot 100]\% \text{ o.r.}$

Max. measured error:  $\pm 0.10\% \pm 1.8 \text{ kg/h} : 8 000 \text{ kg/h} \cdot 100\% = \pm 0.12\%$

**Density (liquid)**

1 g/cc = 1 kg/l

*Standard calibration:*

±0.01 g/cc

*Special density calibration (optional), calibration range: 0.8 to 2.0 g/cc, 5 to 80 °C:*

±0.002 g/cc

*After field density calibration or under reference conditions:*

±0.0005 g/cc

**Temperature**

±0.5 °C ±0.005 · T (T = fluid temperature in °C)

**Repeatability**

**Mass flow (liquid):**

±0.05% ± [1/2 · (zero point stability / measured value) · 100] % o.r.

**Mass flow (gas):**

±0.25% ± [1/2 · (zero point stability / measured value) · 100] % o.r.

**Volume flow (liquid):**

±0.20% ± [1/2 · (zero point stability / measured value) · 100] % o.r.

o.r. = of reading

Zero point stability: see "Max. measured error" → Page 13 ff.

Calculation example (mass flow, liquid):

Given: Promass 83P / DN 25, flow measured value = 8000 kg/h

Repeatability: ±0.05% ± [1/2 · (zero point stability / measured value) · x 100] % o.r.

Repeatability: ±0.05% ± 1/2 · 1.8 kg/h : 8000 kg/h · 100% = ±0.061%

**Density measurement (liquid)**

1 g/cc = 1 kg/l

±0.00025 g/cc

**Temperature measurement**

±0.25 °C ±0.0025 · T (T = fluid temperature in °C)

**Influence of fluid temperature**

When there is a difference between the temperature for zero point adjustment and the process temperature, the typical measured error of the Promass sensor is ±0.0002% of the full scale value / °C.

**Influence of fluid pressure**

The table below shows the effect on accuracy of mass flow due to a difference between calibration pressure and process pressure.

DN	% o.r./bar
8	- 0.002
15	- 0.006
25	- 0.005
40	- 0.005
50	- 0.005

## Operating conditions: Installation

### Installation instructions

Note the following points:

- No special measures such as supports are necessary. External forces are absorbed by the construction of the instrument, for example the secondary containment.
- The high oscillation frequency of the measuring tubes ensures that the correct operation of the measuring system is not influenced by pipe vibrations.
- No special precautions need to be taken for fittings which create turbulence (valves, elbows, T-pieces etc.), as long as no cavitation occurs.
- For mechanical reasons and to protect the pipe, support is recommended for heavy sensors.

### Mounting location

Entrained air or gas bubbles in the measuring tube can result in an increase in measuring errors. Therefore, **avoid** the following mounting locations in the pipe installation:

- Highest point of a pipeline. Risk of air accumulating.
- Directly upstream of a free pipe outlet in a vertical pipeline.

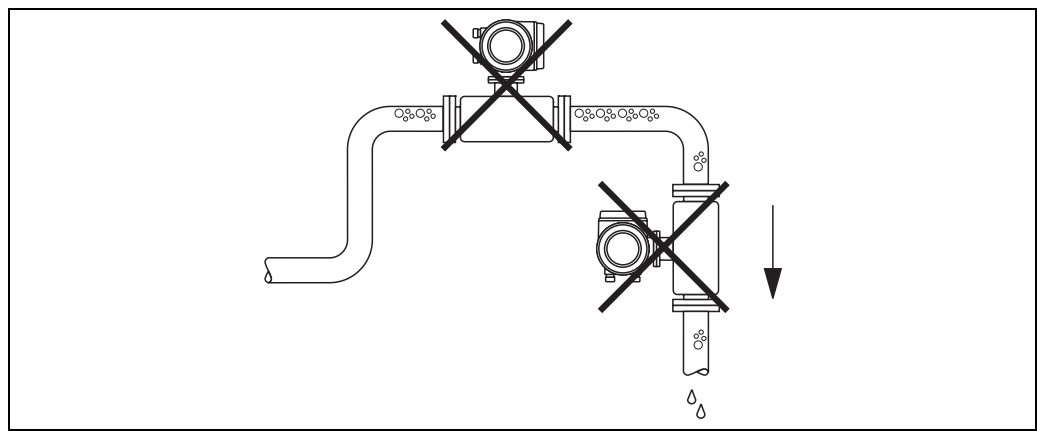

a0003605

Mounting location

Notwithstanding the above, the installation proposal below permits installation in an open vertical pipeline. Pipe restrictions or the use of an orifice with a smaller cross-section than the nominal diameter prevent the sensor running empty while measurement is in progress.

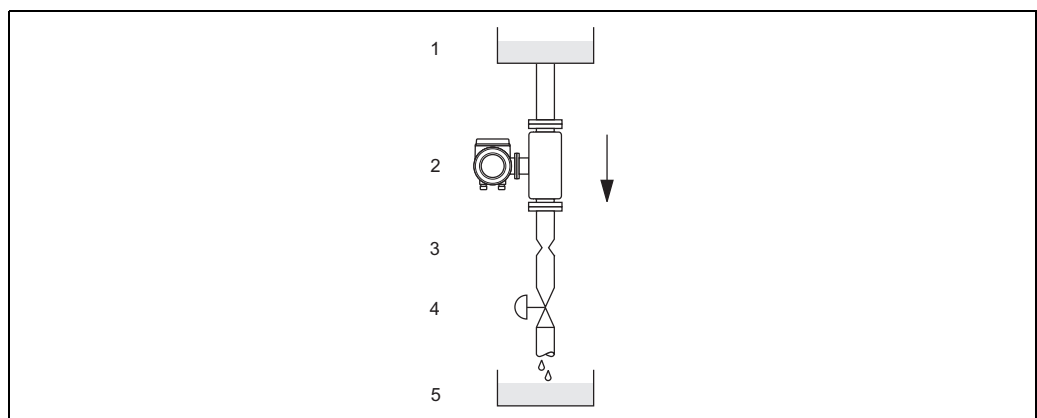

a0003597

Installation in a down pipe (e.g. for batching applications)

1 = Supply tank, 2 = Sensor, 3 = Orifice plate, pipe restriction (see Table), 4 = Valve, 5 = Batching tank

DN	8	15	25	40	50
Ø Orifice plate, pipe restriction [mm]	6	10	14	22	28



**Orientation**

Make sure that the direction of the arrow on the nameplate of the sensor matches the direction of flow (direction of fluid flow through the pipe).

*Vertical (view V)*

Recommended orientation with upward direction of flow. When fluid is not flowing, entrained solids will sink down and gases will rise away from the measuring tube. Thus the measuring tubes can be completely drained and protected against solids buildup.

*Horizontal (view H1 to H3)*

The transmitter can be installed in any orientation in a horizontal pipe run.

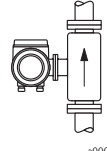
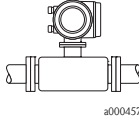
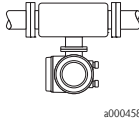
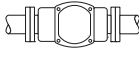
		Standard, compact	Standard, remote
<p><b>Fig. V:</b> Vertical orientation</p>  <p style="text-align: right; font-size: small;">a0004572</p>		✓✓	✓✓
<p><b>Fig. H1:</b> Horizontal orientation Transmitter head up</p>  <p style="text-align: right; font-size: small;">a0004576</p>		✓✓	✓✓
<p><b>Fig. H2:</b> Horizontal orientation Transmitter head down</p>  <p style="text-align: right; font-size: small;">a0004580</p>		✓✓ ①	✓✓ ①
<p><b>Fig. H3:</b> Horizontal orientation Transmitter head to the side</p>  <p style="text-align: right; font-size: small;">A0007558</p>		✓✓	✓✓
<p>✓✓ = Recommended orientation                  ✓ = Orientation recommended in certain situations                  ✗ = Impermissible orientation</p>			

① = To ensure that the maximum permitted ambient temperature for the transmitter (–20 to +60 °C, optionally –40 to +60 °C) is not exceeded, for low-temperature fluids, we recommend the horizontal orientation with the transmitter head up (Fig. H1) or the vertical orientation (Fig. V).

*Special installation instructions for Promass P***Caution!**

When using a bent measuring tube and horizontal installation, the position of the sensor has to be matched to the fluid properties!

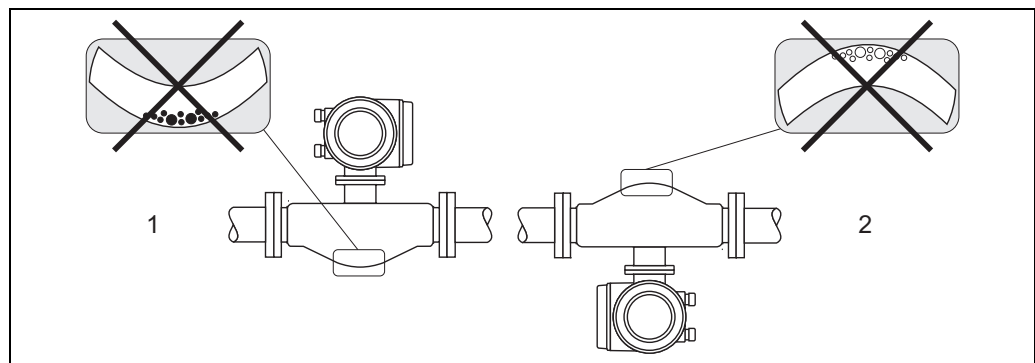
*Horizontal installation for sensors with a bent measuring tube*

- 1 Not suitable for fluids with entrained solids. Risk of solids accumulating.
- 2 Not suitable for outgassing fluids. Risk of air accumulating.

*Special installation instruction for Promass P with Eccentric Tri-clamps*

Eccentric Tri-Clamps can be used to ensure complete drainability when the sensor is installed in a horizontal line. When lines are pitched in a specific direction and at a specific slope, gravity can be used to achieve complete drainability. The sensor must be installed in the correct position with the tube bend facing to the side, to ensure full drainability in the horizontal position. Markings on the sensor show the correct mounting position to optimize drainability.

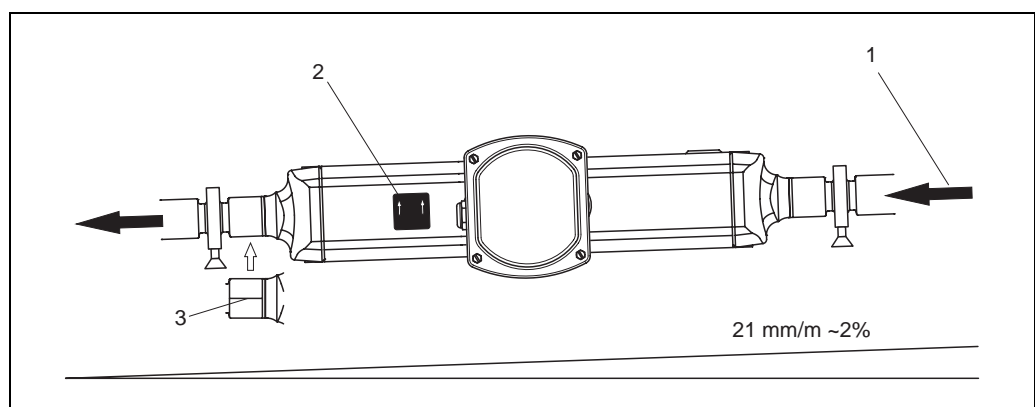

When lines are pitched in a specific direction and at a specific slope: as per hygienic guidelines (21 mm/m or approximately 2%). Gravity can be used to achieve complete drainability.

- 1 The arrow indicates the direction of flow (direction of fluid flow through the pipe).
- 2 The label shows the installation orientation for horizontal drainability.
- 3 The underside of the process connection is indicated by a scribed line. This line indicates the lowest point of the eccentric process connection.

Special installation instruction for Promass P, with hygienic connections (mounting clamp with lining between clamp and instrument)

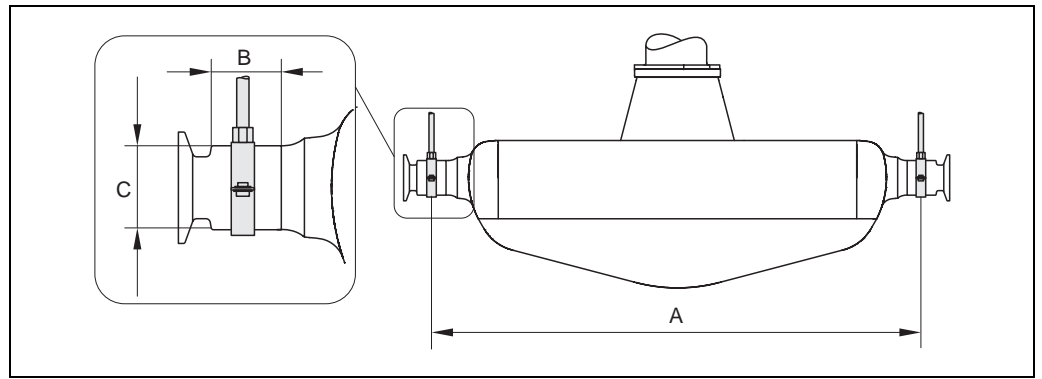

Promass P, mounted with mounting clamp

DN	8	15	25	40	50
A	298	402	542	750	1019
B	33	33	33	36.5	44.1
C	28	28	38	56	75

### Heating

Some fluids require suitable measures to avoid heat transfer at the sensor. Heating can be electric, e.g. with heated elements, or by means of hot water or steam pipes made of copper.



#### Caution!

- Risk of electronics overheating! Consequently, make sure that the adapter between the sensor and transmitter and the connection housing of the remote version always remain free of insulating material. Note that a certain orientation might be required, depending on the fluid temperature. → Page 17
- If using an electric trace heating system whose heating is regulated via phase angle control or pulse packages, influence on the measured values cannot be ruled out due to magnetic fields (i.e. for values that are greater than the values approved by the EN standard (sine 30 A/m)). In such cases, the sensor must be magnetically shielded.

The secondary containment can be shielded with tin plates or electric sheets without preferential direction (e.g. V330-35A) with the following properties:

- Relative magnetic permeability  $\mu_r \geq 300$
- Plate thickness  $d \geq 0.35$  mm

- Information on permitted temperature ranges → Page 20

Special heating jackets, which can be ordered separately from Endress+Hauser as an accessory, are available for the sensors.

#### Inlet and outlet runs

There are no installation requirements regarding inlet and outlet runs.

#### Length of connecting cable

Max. 20 meters (remote version)

#### System pressure

It is important to ensure that cavitation does not occur, because it would influence the oscillation of the measuring tube. No special measures need to be taken for fluids which have properties similar to water under normal conditions.

In the case of liquids with a low boiling point (hydrocarbons, solvents, liquefied gases) or in suction lines, it is important to ensure that pressure does not drop below the vapor pressure and that the liquid does not start to boil. It is also important to ensure that the gases that occur naturally in many liquids do not outgas. Such effects can be prevented when system pressure is sufficiently high.

Therefore, the following locations should be preferred for installation:

- Downstream from pumps (no danger of vacuum)
- At the lowest point in a vertical pipe

## Operating conditions: Environment

<b>Ambient temperature range</b>	Standard: -20 to +60 °C (sensor, transmitter) Optional: -40 to +60 °C (sensor, transmitter)
	Note! <ul style="list-style-type: none"> <li>■ Install the device at a shady location. Avoid direct sunlight, particularly in warm climatic regions.</li> <li>■ At ambient temperatures below -20 °C the readability of the display may be impaired.</li> </ul>
<b>Storage temperature</b>	-40 to +80 °C, preferably +20 °C
<b>Degree of protection</b>	Standard: IP 67 (NEMA 4X) for transmitter and sensor
<b>Shock resistance</b>	According to IEC 68-2-31
<b>Vibration resistance</b>	Acceleration up to 1 g, 10 to 150 Hz, following IEC 68-2-6
<b>Electromagnetic compatibility (EMC)</b>	As per EN 61326/A1 (IEC 1326) and NAMUR recommendation NE 21

## Operating conditions: Process

<b>Fluid temperature range</b>	<b>Sensor</b> -50 to +200 °C
<b>Fluid pressure range (nominal pressure)</b>	<b>Flanges:</b> DIN PN 40 to 63 / ASME B16.5 Cl 150, Cl 300 / JIS 10K, 20K  <b>Pressure ranges of secondary containment:</b> DN 8 to 25: 25 bar DN 40: 16 bar DN 50: 10 bar
	<b>Warning!</b> In case a danger of measuring tube failure exists due to process characteristics, e.g. with corrosive process fluids, we recommend the use of sensors whose secondary containment is equipped with special pressure monitoring connections (ordering option). With the help of these connections, fluid collected in the secondary containment in the event of tube failure can be bled off. This is especially important in high pressure gas applications. These connections can also be used for gas purging (gas detection). Dimensions → Page 22 ff.
<b>Limiting flow</b>	See information in the "Measuring range" section → Page 6  Select nominal diameter by optimizing between required flow range and permissible pressure loss. See the "Measuring range" section for a list of maximum possible full scale values. <ul style="list-style-type: none"> <li>■ The minimum recommended full scale value is approx. 1/20 of the max. full scale value.</li> <li>■ In most applications, 20 to 50% of the maximum full scale value can be considered ideal</li> <li>■ Select a lower full scale value for abrasive substances such as fluids with entrained solids (flow velocity &lt;1 m/s).</li> <li>■ For gas measurement the following rules apply: <ul style="list-style-type: none"> <li>- Flow velocity in the measuring tubes should not be more than half the sonic velocity (0.5 Mach).</li> <li>- The maximum mass flow depends on the density of the gas: formula → Page 6</li> </ul> </li> </ul>

**Pressure loss**

Pressure loss depends on the fluid properties and on the flow rate. The following formulae can be used to approximately calculate the pressure loss:

Reynolds number	$Re = \frac{4 \cdot \dot{m}}{\pi \cdot d \cdot \nu \cdot \rho}$	a0003381
$Re \geq 2300$ *	$\Delta p = K \cdot \nu^{0.25} \cdot \dot{m}^{1.75} \cdot \rho^{-0.75} \cdot \frac{K3 \cdot \dot{m}^2}{\rho}$	a0004631
$Re < 2300$	$\Delta p = K1 \cdot \nu \cdot \dot{m} \cdot \frac{K3 \cdot \dot{m}^2}{\rho}$	a0004633
<p><math>\Delta p</math> = pressure loss [mbar]                      <math>\rho</math> = fluid density [kg/m<sup>3</sup>]  <math>\nu</math> = kinematic viscosity [m<sup>2</sup>/s]              <math>d</math> = inside diameter of measuring tubes [m]  <math>\dot{m}</math> = mass flow [kg/s]                              <math>K</math> to <math>K3</math> = constants (depending on nominal diameter)</p> <p>* To compute the pressure loss for gases, always use the formula for <math>Re \geq 2300</math>.</p>		

**Pressure loss coefficients for Promass P**

DN	d [m]	K	K1	K3
8	$8.31 \cdot 10^{-3}$	$8.78 \cdot 10^6$	$3.53 \cdot 10^7$	$1.30 \cdot 10^6$
15	$12.00 \cdot 10^{-3}$	$1.81 \cdot 10^6$	$9.99 \cdot 10^6$	$1.87 \cdot 10^5$
25	$17.60 \cdot 10^{-3}$	$3.67 \cdot 10^5$	$2.76 \cdot 10^6$	$4.99 \cdot 10^4$
40	$26.00 \cdot 10^{-3}$	$8.00 \cdot 10^4$	$7.96 \cdot 10^5$	$1.09 \cdot 10^4$
50	$40.50 \cdot 10^{-3}$	$1.41 \cdot 10^4$	$1.85 \cdot 10^5$	$1.20 \cdot 10^3$

Pressure loss data includes interface between measuring tube and piping

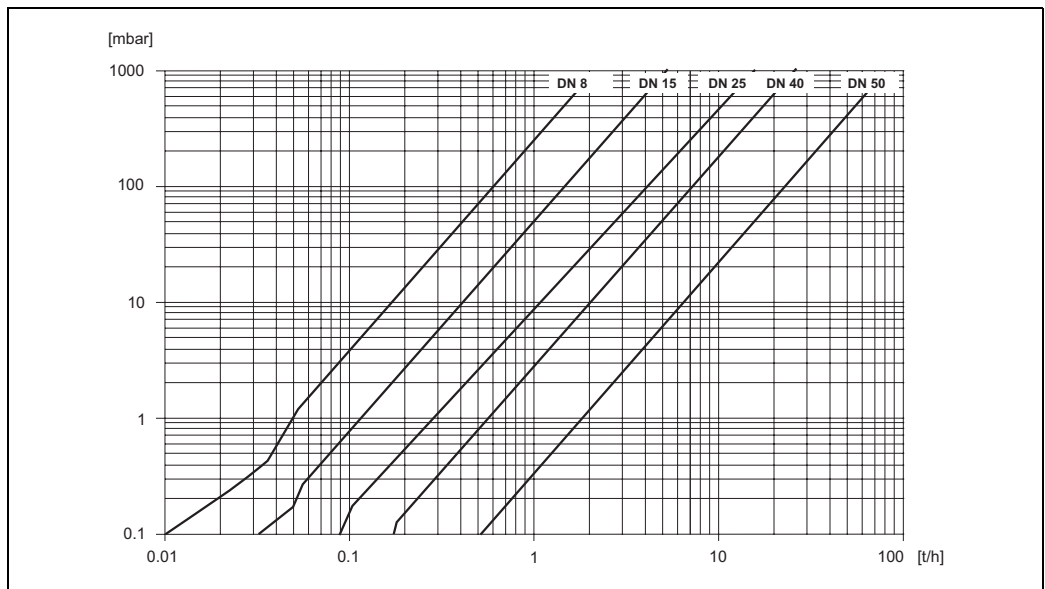

Pressure loss diagram for water

## Mechanical construction

### Design / dimensions

<b>Dimensions:</b>	
Field housing compact version, powder-coated die-cast aluminum	→ Page 23
Transmitter compact version, Stainless Steel field housing	→ Page 23
Dimensions: Remote version	→ Page 24
Transmitter connection housing remote version (II2G/Zone 1)	→ Page 24
Transmitter wall-mount housing (non Ex-zone and II3G/Zone 2)	→ Page 25
Flange connections EN (DIN), ASME B16.5, JIS	→ Page 26
Tri-Clamp	→ Page 28
Eccentric Tri-Clamps	→ Page 29
DIN 11851 (hygienic connection)	→ Page 30
DIN 11864-1 Form A (hygienic connection)	→ Page 31
DIN 11864-2 Form A (flat flange)	→ Page 31
DIN 11864-3 Form A (clamp)	→ Page 32
DIN 32676 (clamp)	→ Page 32
ISO 2852 (clamp)	→ Page 33
ISO 2853 (hygienic connection)	→ Page 33
SMS 1145 (hygienic connection)	→ Page 34
Neumo BioConnect (Clamp)	→ Page 34
Neumo BioConnect (Flange)	→ Page 35
<b>Promass purge connections / secondary containment monitoring</b>	
Purge connections / secondary containment monitoring	→ Page 35

**Field housing compact version, powder-coated die-cast aluminum**

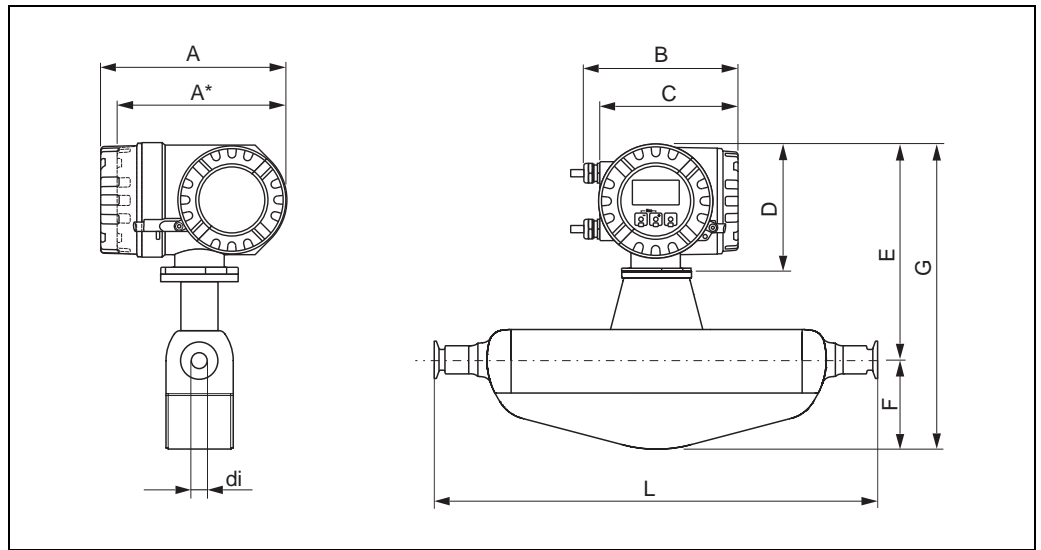

a0006881

A	A*	B	C	D
227	207	187	168	160

All dimensions in [mm];  
 \* Blind version (without local display)

DN	E	F	G	L	di
8	108	280	388	*	*
15	108	280	388	*	*
25	121	280	401	*	*
40	173	304	477	*	*
50	241	315	556	*	*

All dimensions in [mm];  
 \* dependent on respective process connection  
 → For dimensions, see the following pages



Note!  
 Dimensions for transmitters II2G/Zone 1 → Page 24.

**Transmitter compact version, Stainless Steel field housing**

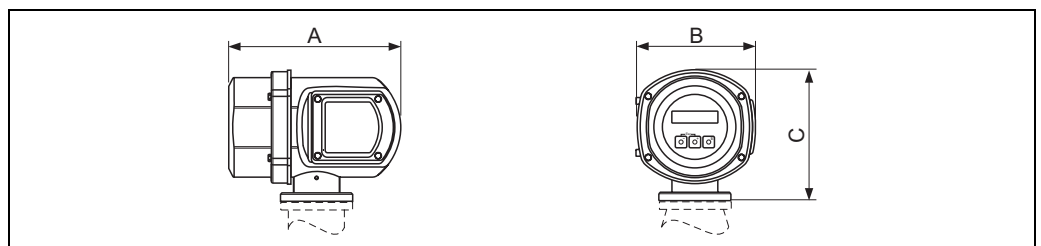

a0002245

A	B	C
220	153	171

All dimensions in [mm]

**Dimensions: Remote version**

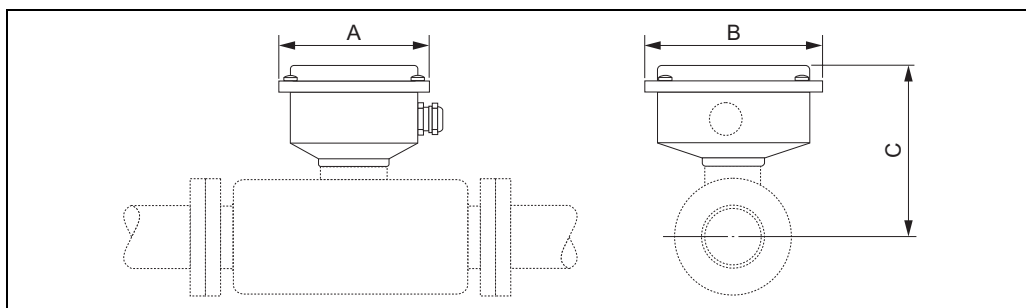

*T = dimension B in the compact version (with corresponding nominal diameter) minus 153 mm*

DN	A	B	C
8	118.5	137.5	113
15	118.5	137.5	113
25	118.5	137.5	113
40	118.5	137.5	118
50	118.5	137.5	130

All dimensions in [mm]

**Transmitter connection housing remote version (II2G/Zone 1)**

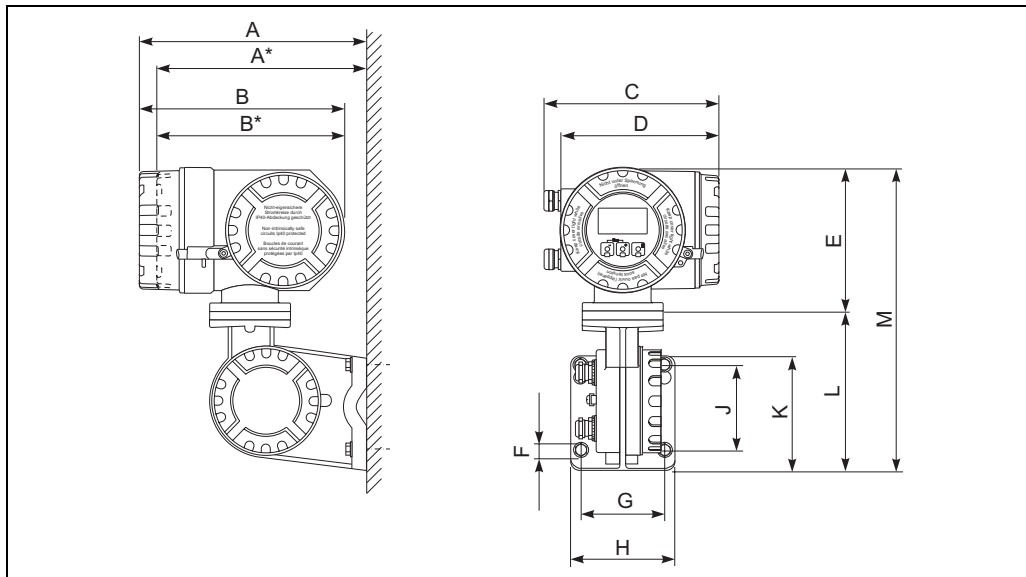

A	A*	B	B*	C	D	E
265	242	240	217	206	186	167

\* Blind version (without local display)

F	G	H	J	K	L	M
∅ 8.6 (M8)	100	123	100	133	188	355

All dimensions in [mm]



Transmitter wall-mount housing (non Ex-zone and II3G/Zone 2)

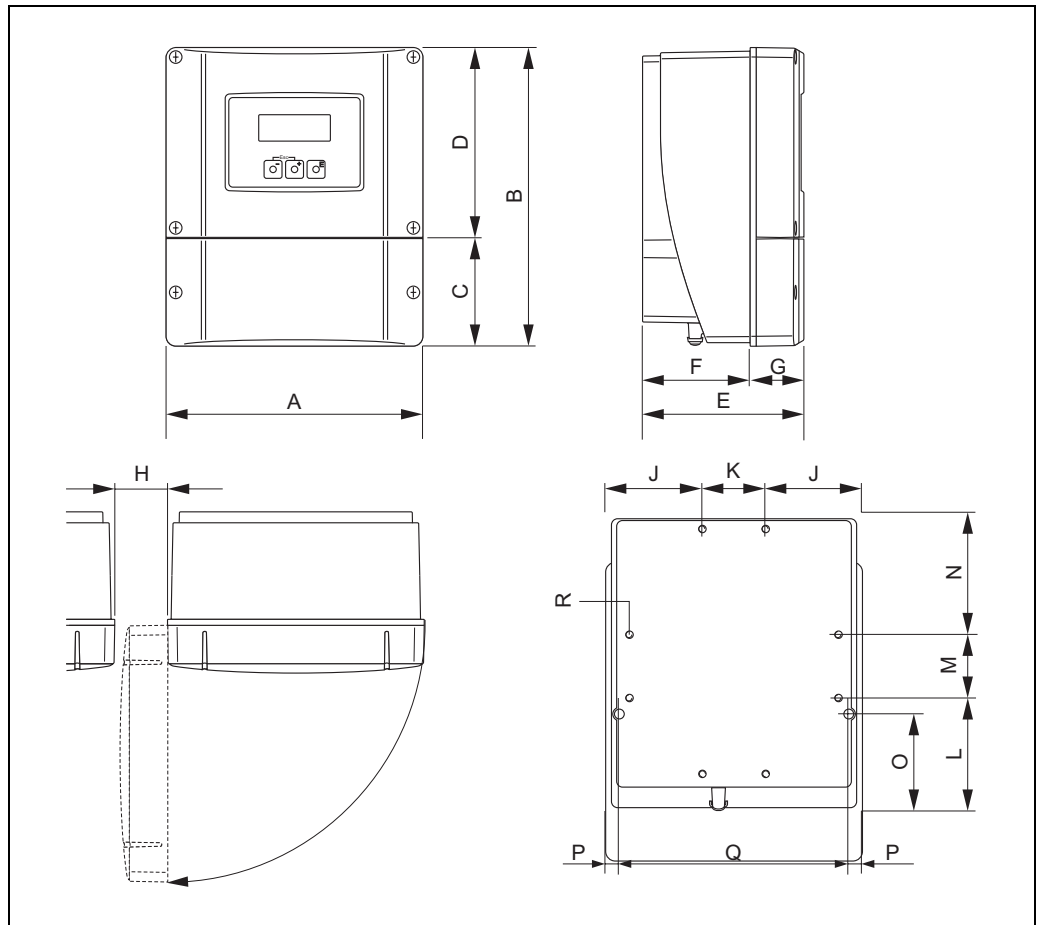

a0001150

A	B	C	D	E	F	G	H	J
215	250	90.5	159.5	135	90	45	>50	81
K	L	M	N	O	P	Q	R	
53	95	53	102	81.5	11.5	192	8xM5	

All dimensions in [mm]

## Flange connections EN (DIN), ASME B16.5, JIS

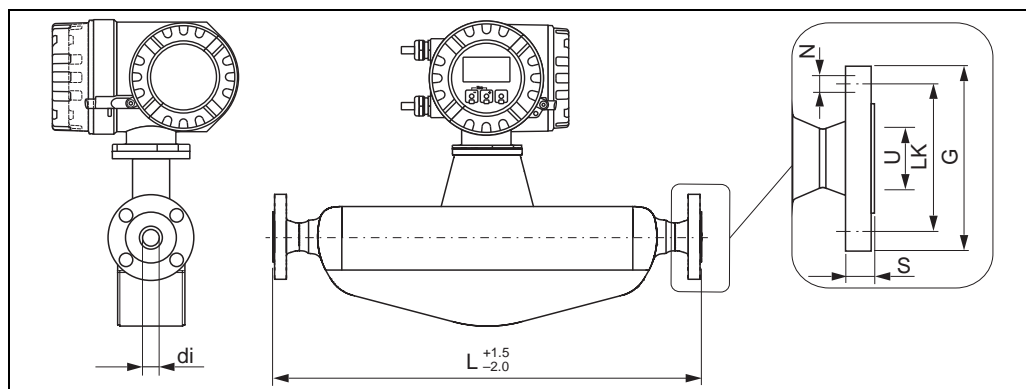

a0006883-en

**Flange EN 1092-1 (DIN 2501) / PN 40: 1.4404/316L/316**

Surface roughness (flange): EN 1092-1 Form B1 (DIN 2526 Form C), Ra 6.3 to 12.5 µm

DN	G	L	N	S	LK	U	di
8 <sup>1)</sup>	95.0	336	4 x Ø14	17.0	65.0	17.30	8.31
15	95.0	440	4 x Ø14	20	65	17.30	12.00
25	115.0	580	4 x Ø14	19.0	85.0	28.50	17.60
40	150.0	794	4 x Ø18	21.0	110.0	43.10	26.00
50	165.0	1071	4 x Ø18	25.0	125.0	54.50	40.50

All dimensions in [mm]; Further dimensions → Page 23 ff.

<sup>1)</sup> DN 8 with DN 15 flanges as standard**Flange EN 1092-1 (DIN 2501) / PN 63: 1.4404/316L/316**

Surface roughness (flange): EN 1092-1 Form B1 (DIN 2526 Form C), Ra 6.3 to 12.5 µm

DN	G	L	N	S	LK	U	di
50	180.0	1083	4 x Ø22	29.0	135.0	54.50	40.50

All dimensions in [mm]; Further dimensions → Page 23 ff.

**Flange according to ASME B16.5 / Cl 150: 1.4404/316L/316**

Surface roughness (flange): Ra 3.2 to 6.3 µm

DN	G	L	N	S	LK	U	di
8 <sup>1)</sup>	3/8"	88.9	4 x Ø15.7	17.1	60.5	15.70	8.31
15	1/2"	88.9	4 x Ø15.7	17.1	60.5	15.70	12.00
25	1"	108.0	4 x Ø15.7	17.6	79.2	26.70	17.60
40	1 1/2"	127.0	4 x Ø15.7	18.6	98.6	40.90	26.00
50	2"	152.4	4 x Ø19.1	25.1	120.7	52.60	40.50

All dimensions in [mm]; Further dimensions → Page 23 ff.

<sup>1)</sup> DN 8 with DN 15 flanges as standard

<b>Flange according to ASME B16.5 / CI 300: 1.4404/316L/316</b>								
Surface roughness (flange): Ra 3.2 to 6.3 µm								
DN	G	L	N	S	LK	U	di	
8 <sup>1)</sup>	3/8"	95.2	336	4 x Ø15.7	16.6	66.5	15.70	8.31
15	1/2"	95.2	440	4 x Ø15.7	16.6	66.5	15.70	12.00
25	1"	123.9	580	4 x Ø19.1	18.1	88.9	26.70	17.60
40	1 1/2"	155.4	794	4 x Ø22.3	24.6	114.3	40.90	26.00
50	2"	165.1	1071	8 x Ø19.1	27.6	127.0	52.60	40.50

All dimensions in [mm]; Further dimensions → Page 23 ff.  
<sup>1)</sup> DN 8 with DN 15 flanges as standard

<b>Flange JIS B2238 / 20K: 1.4404/316L/316</b>								
Surface roughness (flange): Ra 3.2 to 6.3 µm								
DN	G	L	N	S	LK	U	di	
8 <sup>1)</sup>	95	336	4 x Ø15	16	70	15.00	8.31	
15	95	440	4 x Ø15	16	70	15.00	12.00	
25	125	580	4 x Ø19	17.5	90.0	25.00	17.60	
40	140	794	4 x Ø19	20.0	105.0	40.00	26.00	
50	155	1071	8 x Ø19	27.5	120.0	50.00	41.50	

All dimensions in [mm]; Further dimensions → Page 23 ff.  
<sup>1)</sup> DN 8 with DN 15 flanges as standard

<b>Flange JIS B2238 / 40K: 1.4404/316L/316</b>								
Surface roughness (flange): Ra 3.2 to 6.3 µm								
DN	G	L	N	S	LK	U	di	
8 <sup>1)</sup>	115	336	4 x Ø19	21	80	15.00	8.31	
15	115	440	4 x Ø19	21	80	15.00	12.00	
25	130	589	4 x Ø19	22.0	95.0	25.00	17.60	
40	160	804	4 x Ø23	26.0	120.0	38.00	26.00	
50	165	1071	8 x Ø19	26.0	130.0	50.00	40.50	

All dimensions in [mm]; Further dimensions → Page 23 ff.  
<sup>1)</sup> DN 8 with DN 15 flanges as standard

### Tri-Clamp

All Tri-Clamp connections correspond to the relevant ASME BPE hygienic clamp dimensions.

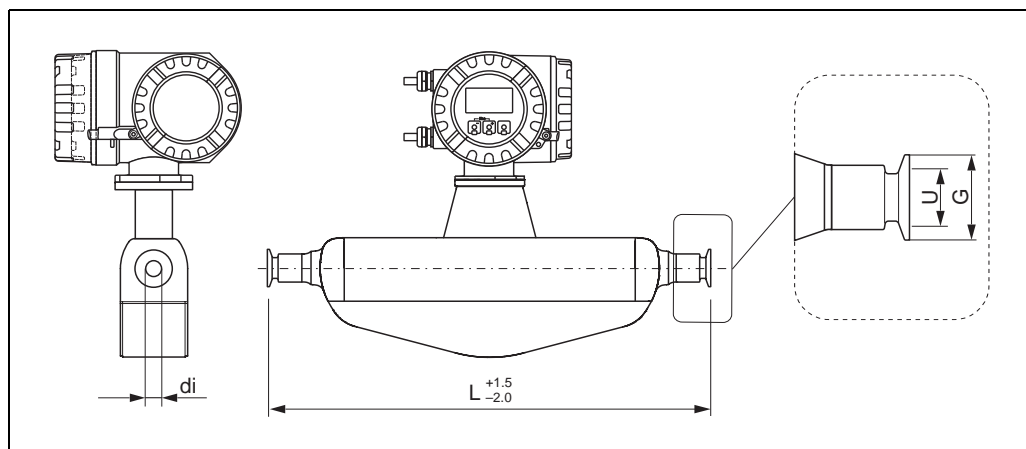

<b>1", 1½", 2" -Tri-Clamp: 1.4435/316L</b>					
DN	Clamp	G	L	U	di
8	1"	50.4	362	22.10	8.31
15	1"	50.4	466	22.10	12.00
25	1"	50.4	606	22.10	17.60
40	1½"	50.4	818	34.80	26.00
50	2"	63.9	1096	47.50	40.50

All dimensions in [mm]; Further dimensions → Page 23 ff.  
Version available  $Ra_{max} = 0.76 \mu\text{m}$  or  $Ra_{max} = 0.38 \mu\text{m}$  electropolished

<b>¾" Tri-Clamp: 1.4435/316L</b>					
DN	Clamp	G	L	U	di
8	¾"	25.0	362	15.75	8.31
15	¾"	25.0	466	15.75	12.00

All dimensions in [mm]; Further dimensions → Page 23 ff.  
Version available  $Ra_{max} = 0.76 \mu\text{m}$  or  $Ra_{max} = 0.38 \mu\text{m}$  electropolished

<b>½" Tri-Clamp: 1.4435/316L</b>					
DN	Clamp	G	L	U	di
8	½"	25.0	362	9.40	8.31
15	½"	25.0	466	9.40	12.00

All dimensions in [mm]; Further dimensions → Page 23 ff.  
Version available  $Ra_{max} = 0.76 \mu\text{m}$  or  $Ra_{max} = 0.38 \mu\text{m}$  electropolished

**Eccentric Tri-Clamps**

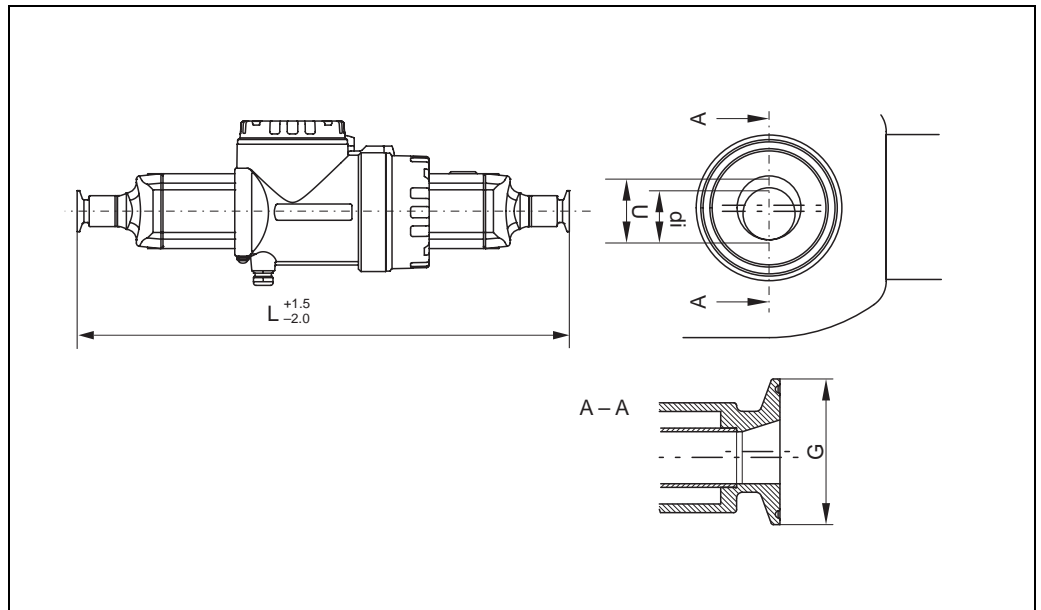

a0007385-en

<b>Eccentric Tri-Clamps: 1.4435/316L</b>					
DN	Clamp	G	L	U	di
8	1/2"	25.0	362	9.4	8.31
15	3/4"	25.0	466	15.75	12.00
25	1"	50.4	606	22.1	17.60
40	1½"	50.4	825	34.8	26.00
50	2"	63.9	1103	47.5	40.50

All dimensions in [mm]; Further dimensions → Page 23 ff.  
 Version available Ra<sub>max</sub> = 0.76 µm or Ra<sub>max</sub> = 0.38 µm electropolished



Note!

Further information refer to "Special installation instruction for Promass P with Eccentric Tri-clamps"  
 → Page 18

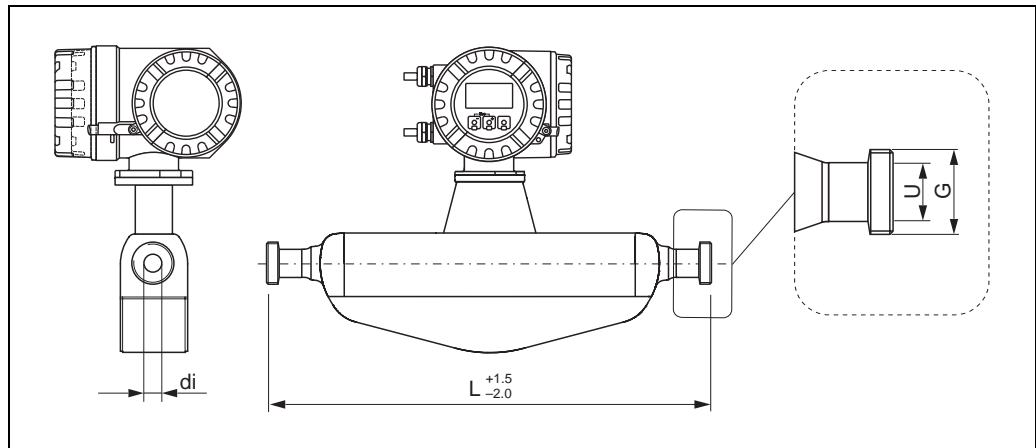
**DIN 11851 (hygienic connection)**

a0006885-en

<b>Hygienic connection DIN 11851: 1.4435/316L</b>				
DN	G	L	U	di
8	Rd 34 x 1/8"	362	16.00	8.31
15	Rd 34 x 1/8"	466	16.00	12.00
25	Rd 52 x 1/6"	606	26.00	17.60
40	Rd 65 x 1/6"	825	38.00	26.00
50	Rd 78 x 1/6"	1107	50.00	40.50

All dimensions in [mm]; Further dimensions → Page 23 ff.  
Version available  $Ra_{max} = 0.76 \mu\text{m}$  or  $Ra_{max} = 0.38 \mu\text{m}$  electropolished

<b>Hygienic connection Rd 28 x 1/8" DIN 11851: 1.4435/316L</b>				
DN	G	L	U	di
8	Rd 28x 1/8"	362	10.00	8.31
15	Rd 28x 1/8"	466	10.00	12.00

All dimensions in [mm]; Further dimensions → Page 23 ff.  
Version available  $Ra_{max} = 0.76 \mu\text{m}$  or  $Ra_{max} = 0.38 \mu\text{m}$  electropolished

**DIN 11864-1 Form A (hygienic connection)**

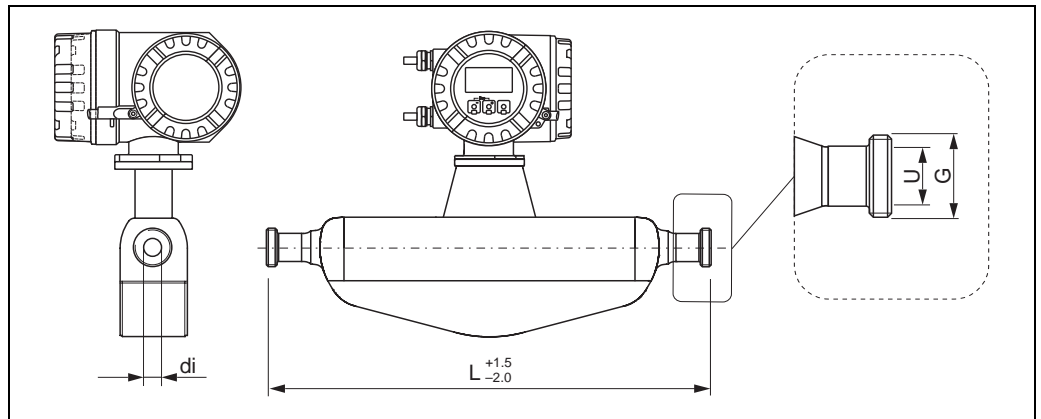

a0006886-en

Hygienic connection DIN 11864-1 Form A: 1.4435/316L				
DN	G	L	U	di
8	Rd 34 x 1/8"	362	16.00	8.31
15	Rd 34 x 1/8"	466	16.00	12.00
25	Rd 52 x 1/6"	620	26.00	17.60
40	Rd 65 x 1/6"	825	38.00	26.00
50	Rd 78 x 1/6"	1107	50.00	40.50

All dimensions in [mm]; Further dimensions → Page 23 ff.  
Version available  $Ra_{max} = 0.76 \mu m$  or  $Ra_{max} = 0.38 \mu m$  electropolished

**DIN 11864-2 Form A (flat flange)**

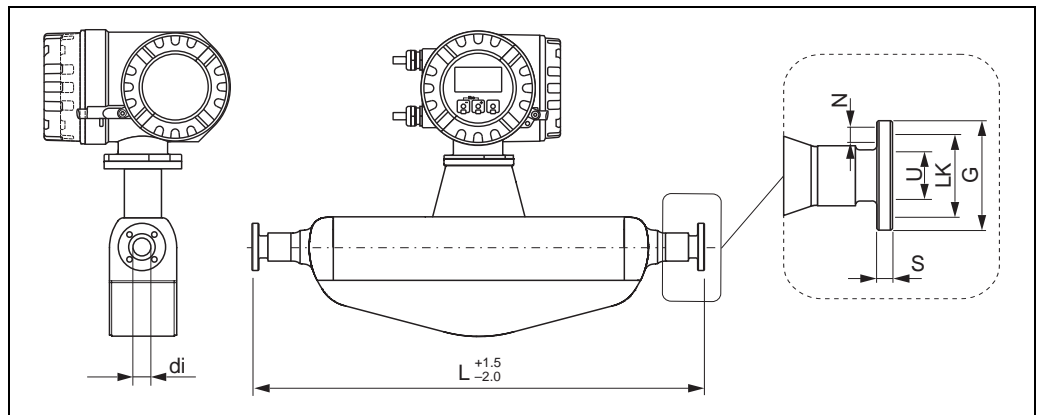

a0006887-en

DIN 11864-2 Form A (flat flange): 1.4435/316L							
DN	G	L	N	S	LK	U	di
8	59.0	384	4 x Ø9	10	42	16.00	8.31
15	59.0	488	4 x Ø9	10	42	16.00	12.00
25	70	626	4 x Ø9	10	53	26.00	17.60
40	82	840	4 x Ø9	10	65	38.00	26.00
50	94	1120	4 x Ø9	10	77	50.00	40.50

All dimensions in [mm]; Further dimensions → Page 23 ff.  
Version available  $Ra_{max} = 0.76 \mu m$  or  $Ra_{max} = 0.38 \mu m$  electropolished

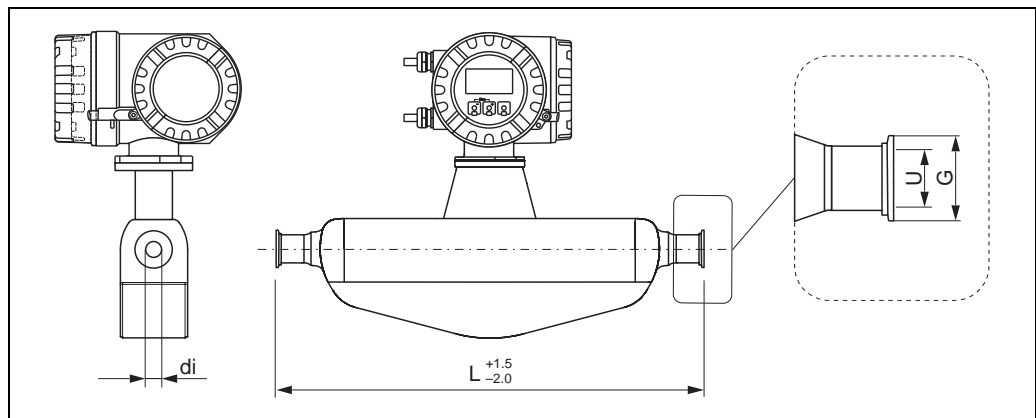
**DIN 11864-3 Form A (clamp)**

a0006888-en

**Clamp DIN 11864-3 Form A: 1.4435/316L**

DN	G	L	U	di
8	34.0	370	16.05	8.31
15	34.0	474	16.05	12.00
25	50.5	614	26.05	17.60
40	64.0	825	38.05	26.00
50	77.5	1096	50.05	40.50

All dimensions in [mm]; Further dimensions → Page 23 ff.

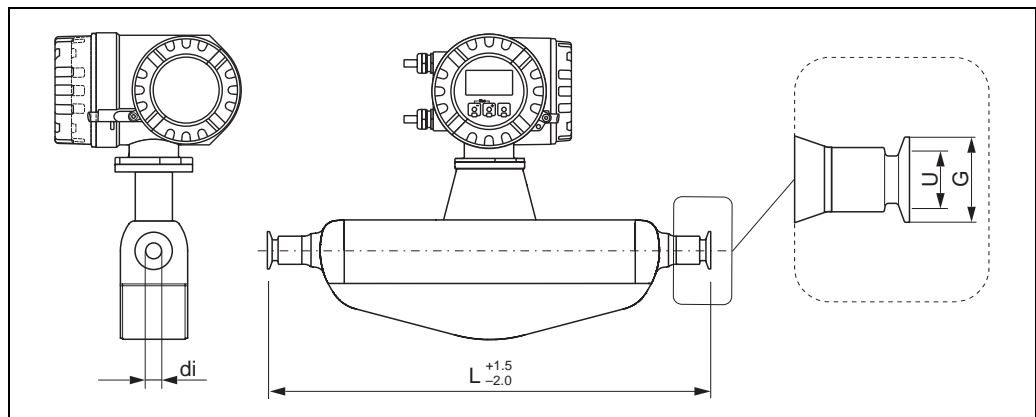
Version available  $Ra_{max} = 0.76 \mu\text{m}$  or  $Ra_{max} = 0.38 \mu\text{m}$  electropolished**DIN 32676 (clamp)**

a0006884-en

**Clamp DIN 32676: 1.4435/316L**

DN	G	L	U	di
8	34.0	362	16.00	8.31
15	34.0	466	16.00	12.00
25	50.5	606	26.00	17.60
40	50.5	819	38.00	26.00
50	64.0	1097	50.00	40.50

All dimensions in [mm]; Further dimensions → Page 23 ff.

Version available  $Ra_{max} = 0.76 \mu\text{m}$  or  $Ra_{max} = 0.38 \mu\text{m}$  electropolished



**ISO 2852 (clamp)**

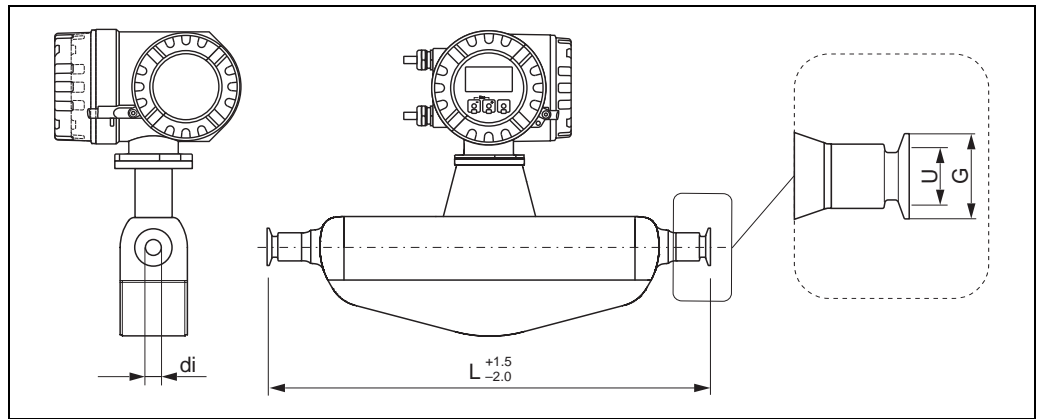

a0006884-en

**Clamp ISO 2852: 1.4435/316L**

DN	G	L	U	di
8	50.5	362	22.60	8.31
15	50.5	466	22.60	12.00
25	50.5	606	22.60	17.60
40	50.5	818	35.60	26.00
50	64.0	1096	48.60	40.50

All dimensions in [mm]; Further dimensions → Page 23 ff.  
Version available  $Ra_{max} = 0.76 \mu m$  or  $Ra_{max} = 0.38 \mu m$  electropolished

**ISO 2853 (hygienic connection)**

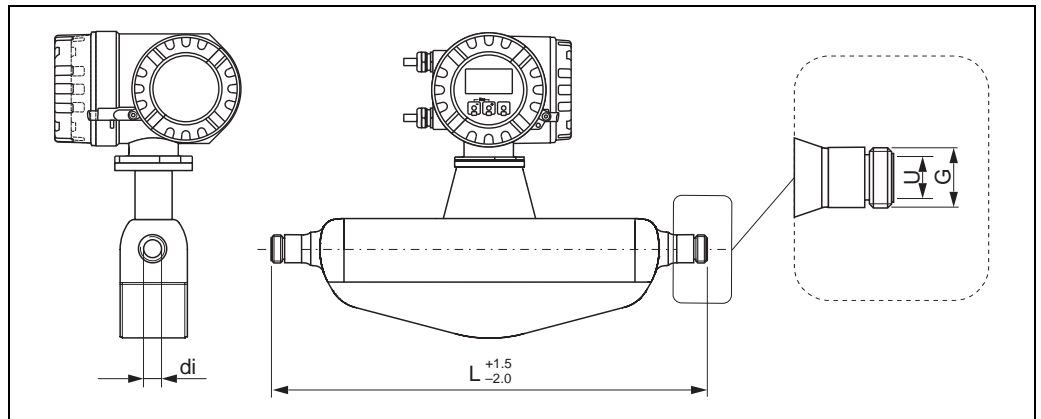

a0006889-en

**Hygienic connection ISO 2853: 1.4435/316L**

DN	G	L	U	di
8	37.13	370	22.60	8.31
15	37.13	474	22.60	12.00
25	37.13	614	22.60	17.60
40	50.65	829	35.60	26.00
50	64.1	1107	48.60	40.50

All dimensions in [mm]; Further dimensions → Page 23 ff.  
Version available  $Ra_{max} = 0.76 \mu m$  or  $Ra_{max} = 0.38 \mu m$  electropolished

**SMS 1145 (hygienic connection)**

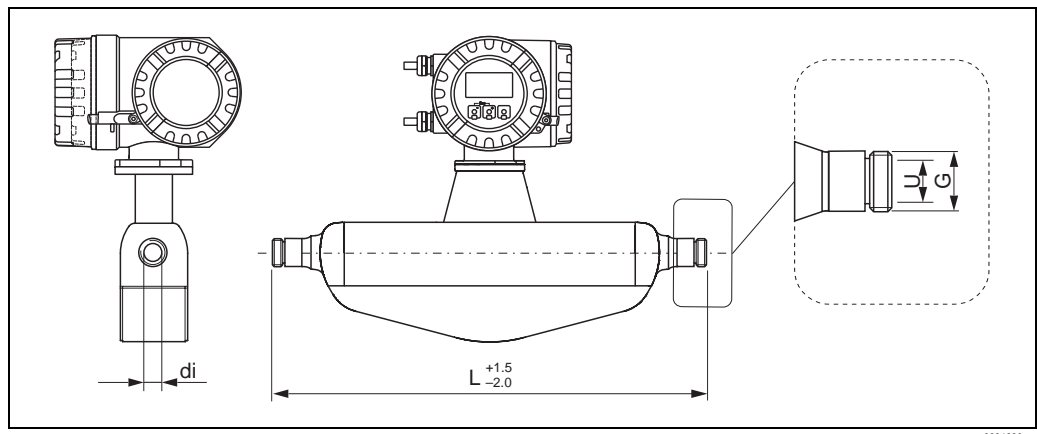

a0006890-en

**Hygienic connection SMS 1145: 1.4435/316L**

DN	G	L	U	di
8	Rd 40 x 1/6"	362	22.50	8.31
15	Rd 40 x 1/6"	466	22.50	12.00
25	Rd 40 x 1/6"	606	22.50	17.60
40	Rd 60 x 1/6"	829	35.50	26.00
50	Rd 70 x 1/6"	1107	48.50	40.50

All dimensions in [mm]; Further dimensions → Page 23 ff.  
Version available  $Ra_{max} = 0.76 \mu\text{m}$  or  $Ra_{max} = 0.38 \mu\text{m}$  electropolished

**Neumo BioConnect (Clamp)**

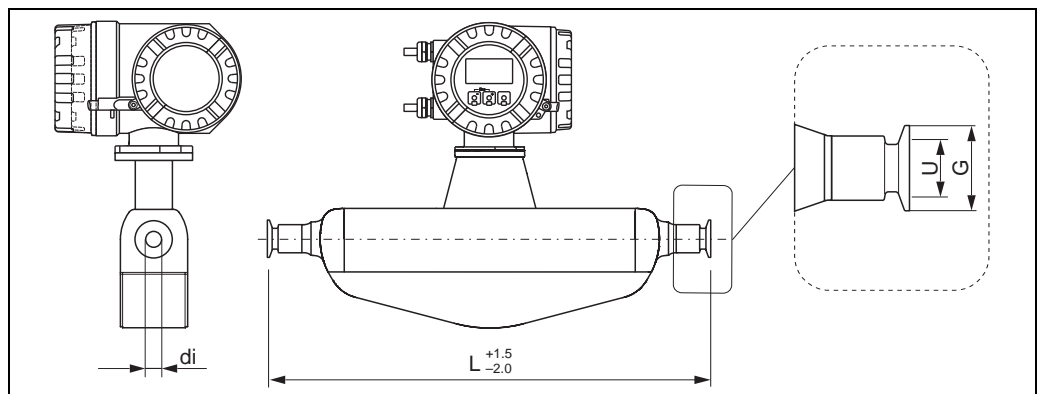

a0006884-en

**Neumo BioConnect Clamp: 1.4435/316L**

DN	G	L	U	di
8	25	362	10.00	8.31
15	25	466	16.00	12.00
25	50.4	606	26.00	17.60
40	64.0	819	38.00	26.00
50	77.4	1097	50.00	40.50

All dimensions in [mm]; Further dimensions → Page 23 ff.  
Version available  $Ra_{max} = 0.76 \mu\text{m}$  or  $Ra_{max} = 0.38 \mu\text{m}$  electropolished

**Neumo BioConnect (Flange)**

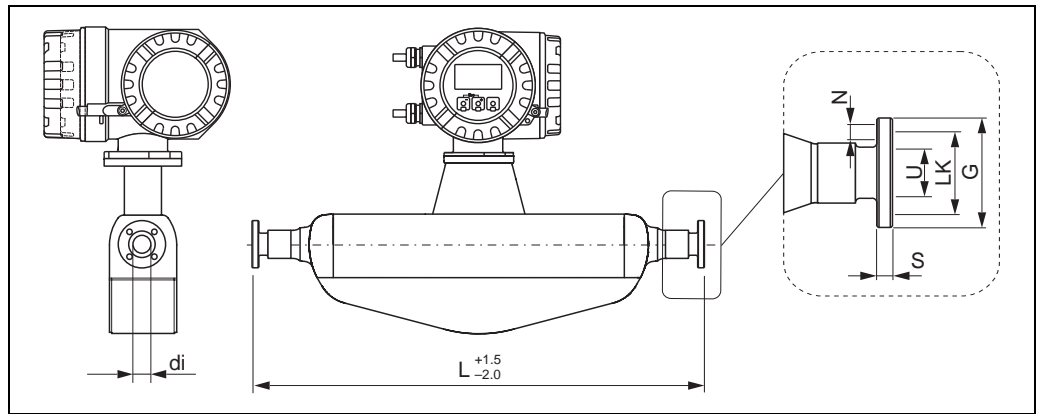

a0006887-en

Neumo BioConnect flange: 1.4435/316L							
DN	G	L	N	S	LK	U	di
8	65	384	4 x Ø9	10	45	10.00	8.31
15	75	488	4 x Ø9	10	55	16.00	12.00
25	85	626	4 x Ø9	12	65	26.00	17.60
40	100	840	4 x Ø9	12	80	38.00	26.00
50	110	1120	4 x Ø9	14	90	50.00	40.50

All dimensions in [mm]; Further dimensions → Page 23 ff.  
Version available Ra<sub>max</sub> = 0.76 µm or Ra<sub>max</sub> = 0.38 µm electropolished

**Purge connections / secondary containment monitoring**



Caution!

The secondary containment is filled with dry nitrogen (N<sub>2</sub>). Do not open the purge connections unless the containment can be filled immediately with a dry inert gas. Use only low gauge pressure to purge. Maximum pressure: 5 bar.

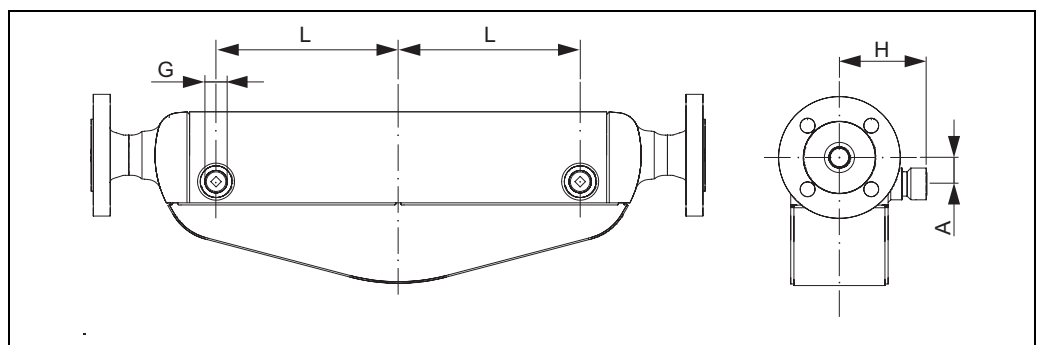

a0003288

DN	L	H	A	G
8	55	82	25	1/2" NPT
15	102	82	25	1/2" NPT
25	172	82	25	1/2" NPT
40	263	102	45	1/2" NPT
50	381.5	119.5	58	1/2" NPT

All dimensions in [mm]; Further dimensions → Page 23 ff.  
Version available Ra<sub>max</sub> = 0.76 µm or Ra<sub>max</sub> = 0.38 µm electropolished

**Weight**

- Compact version: see table below
- Remote version
  - Sensor: see table below
  - Wall-mount housing: 5 kg

DN	8	15	25	40	50
Compact version	13	15	21	43	80
Remote version	11	13	19	41	78

All values (weight) refer to devices with EN/DIN PN 40 flanges.  
Weight information in [kg].

**Materials****Transmitter housing:**

- Compact housing: Stainless Steel 1.4301/ASTM 304
- Compact housing: powder coated die-cast aluminum
- Wall-mount housing: powder coated die-cast aluminum
- Remote field housing: powder-coated die-cast aluminum

**Sensor housing / containment:**

- Acid and alkali-resistant outer surface
- Stainless Steel 1.4301/ASTM 304

**Connection housing, sensor (remote version):**

- Stainless Steel 1.4301/ASTM 304

**Process connections**

All hygienic process connection are 3A approved and EHEDG certified  
All Tri-Clamp connections correspond to the relevant ASME BPE hygienic clamp dimensions

*Stainless Steel 1.4435/316L*

- DIN 11864-2 Form A (flat flange)
- Flange Neumo BioConnect
- Hygienic connection:
  - DIN 11864-1, Form A
  - DIN 11851
  - SMS 1145
  - ISO 2853
- Tri-Clamp
- Tri-Clamp (Eccentric)
- Clamp aseptic according to
  - DIN 11864-3, Form A
  - DIN 32676
  - ISO 2852
  - Neumo BioConnect

*Stainless Steel 1.4404/316/316L*

- Flanges EN 1092-1 (DIN 2501)
- Flanges JIS B2238
- Flanges according to ASME B16.5

**Measuring tubes:**

- Stainless Steel 1.4435/316L
- Wetted parts surface finish (measuring tube and process connection)
- Finish quality:
  - $Ra_{max} = 0.76 \mu\text{m}$  (mechanically polished)
  - $Ra_{max} = 0.38 \mu\text{m}$  (electropolished)

**Material load curves**

**Flange connection to EN 1092-1 (DIN 2501)**

Flange material: 1.4404

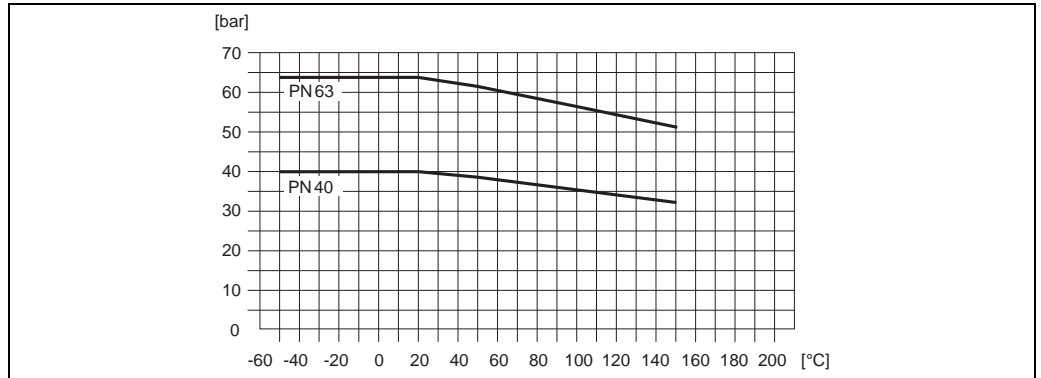

a0006625-en

**Flange connection according to ASME B16.5**

Flange material: 316/316L



a0006827-en

**Flange connection to JIS B2238**

Flange material: 1.4404/316/316L

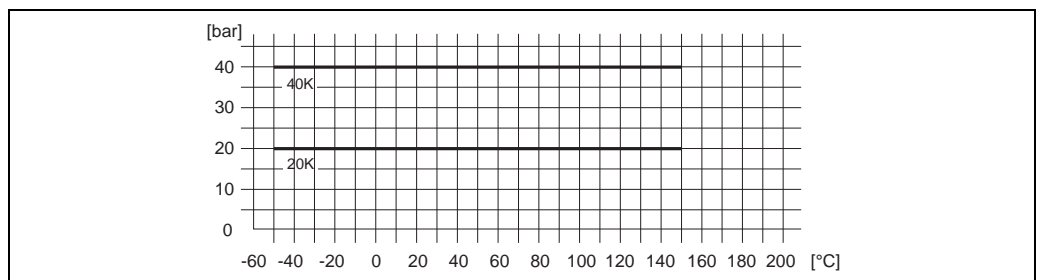

a0006872-en

**Flange connection to DIN 11864-2 Form A (flat flange)**

Flange material: 1.4435/316L

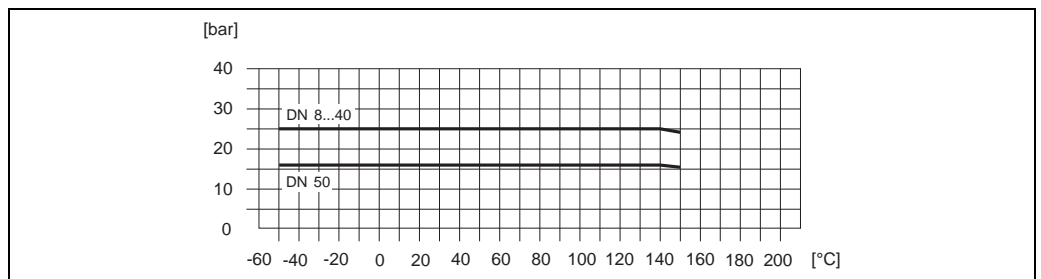

a0006866-en

**Neumo BioConnect Flange**

Flange material: 1.4435/316L

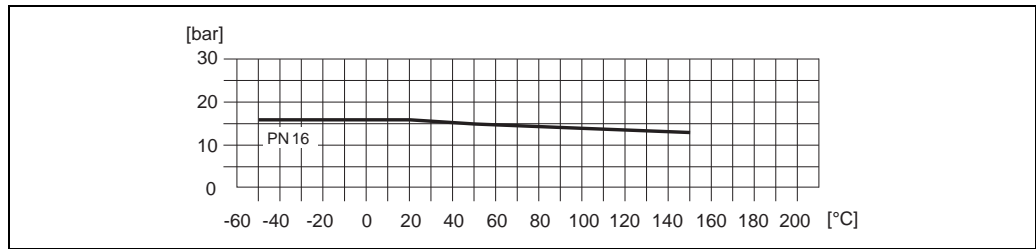

a0003305-en

**Hygienic connection to DIN 11864-1 Form A (flat flange), DIN 11851 and SMS 1145**

Connection material: 1.4435/316L

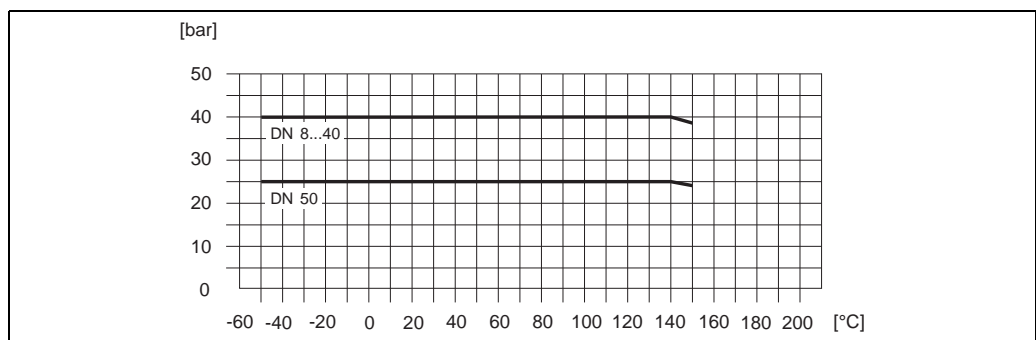

a0006871-en

**Coupling to ISO 2853**

Connection material: 1.4435/316L

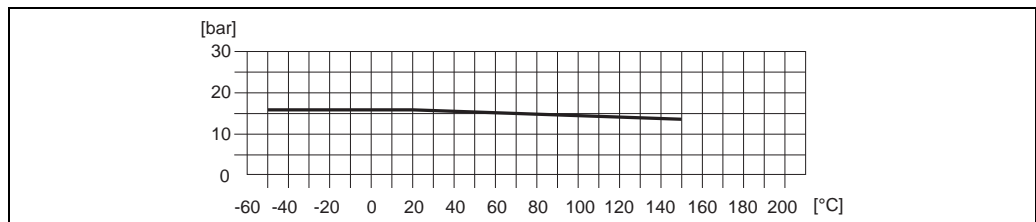

a0003308-en

**Tri-Clamp process connection, ISO 2852 connections (clamp), DIN 32676 (clamp) and Neumo BioConnect (Clamp)**

The load limit is defined exclusively by the material properties of the outer clamp used. This clamp is not included in the scope of delivery.

---

## Human interface

---

### Display elements

- Liquid-crystal display: backlit, two lines (Promass 80) or four lines (Promass 83) with 16 characters per line
- Selectable display of different measured values and status variables
- At ambient temperatures below  $-20\text{ °C}$  the readability of the display may be impaired.

### Unified control concept for both types of transmitter

#### Promass 80:

- Local operation with three keys (-, +, E)
- Quick Setup menus for straightforward commissioning

#### Promass 83:

- Local operation with three optical keys ( $\square/\square/\square$ )
- Application-specific Quick Setup menus for straightforward commissioning

### Language groups



Note!

The language group is changed using the "FieldCare" operating program.

Language groups available for operation in different countries:

- Western Europe and America (WEA):  
English, German, Spanish, Italian, French, Dutch and Portuguese
- Eastern Europe/Scandinavia (EES):  
English, Russian, Polish, Norwegian, Finnish, Swedish and Czech
- South and Eastern Asia (SEA):  
English, Japanese, Indonesian

#### Only Promass 83:

- China (CN):  
English, Chinese

### Remote operation

#### Promass 80:

Remote operation via HART, PROFIBUS PA

#### Promass 83:

Remote operation via HART, PROFIBUS PA/DP, FOUNDATION fieldbus

---

## Certificates and approvals

---

### CE mark

The measuring system is in conformity with the statutory requirements of the EC Directives. Endress+Hauser confirms successful testing of the device by affixing to it the CE mark.

### C-Tick symbol

The measuring system complies with the EMC requirements of the "Australian Communications and Media Authority (ACMA)"

### Ex approval

Information about currently available Ex versions (ATEX, FM, CSA, IECEx, NEPSI etc.) can be supplied by your Endress+Hauser Sales Center on request. All information relevant to explosion protection is available in separate Ex documents that you can order as necessary.

### Hygienic compatibility

- 3A approval
- EHEDG tested
- ASME BPE Certificate of Compliance to relevant scope

The scope is based on the ASME BPE 2005 Standard and is subject to revisions based on changes made in the Standard. The measuring device fulfills the requirements of Parts; GR, SD, DT, MJ, and SF that are deemed relevant to a Coriolis Mass Flow measuring system.

**Flow calibration**

- Factory calibration, standard 2-point or 5 point:  
Verification of the measuring accuracy with adjustment of the meter on a production flow rig. Accuracy and linearity are both recorded, the meter is supplied with a calibration certificate.
- SCS/A2LA/CNAS calibration, standard 5-point:  
Traceable calibration with adjustment of the meter on an accredited flow rig. Measuring uncertainty of the calibration rig has been officially verified and based on international standards. Accreditation of calibration facility is according to ISO/IEC 17025 (Reinach, Cernay, Greenwood, Aurangabad and Suzhou). The calibration certificate bears the stamp of the calibration laboratory and are signed by the certified operator and countersigned by the head of the facility.

**TSE compliance**

Endress+Hauser declare, that no material with animal origin or ingredients of animal origin are being used during the entire production of Promass sensors produced in our Reinach / Switzerland, Cernay / France, Greenwood / USA or Aurangabad/India production facilities.  
In addition we do not use any material of animal origin during the polishing processes.  
Endress+Hauser therefore can confirm to TSE compliance.

**Additional test and Inspections**

The following tests and inspection are offered as standard:

- MTR (Material Test Reports) or EN 10204 3.1 material Inspection certificate
- Pressure test for the measuring tube and a type test for the secondary containment
- Cleaned from Oil and Grease
- Roughness measurement
- Delta Ferrite measurement

The above mentioned tests and inspections are available on a CoC (Certificate of compliance) or an EN 10204 3.1 certificate. Additional inspections and tests are available upon request please contact your local Endress+Hauser sales organization for further information.

**FOUNDATION Fieldbus certification**

The flow device has successfully passed all the test procedures carried out and is certified and registered by the Fieldbus FOUNDATION. The device thus meets all the requirements of the following specifications:

- Certified to FOUNDATION Fieldbus Specification
- The device meets all the specifications of the FOUNDATION Fieldbus H1.
- Interoperability Test Kit (ITK), revision status 4.0 (device certification number: on request)
- The device can also be operated with certified devices of other manufacturers
- Physical Layer Conformance Test of the Fieldbus FOUNDATION

**PROFIBUS DP/PA certification**

The flow device has successfully passed all the test procedures carried out and is certified and registered by the PNO (PROFIBUS User Organization). The device thus meets all the requirements of the following specifications:

- Certified in accordance with PROFIBUS Profile Version 3.0 (device certification number: available on request)
- The device can also be operated with certified devices of other manufacturers (interoperability)

**MODBUS certification**

The measuring device meets all the requirements of the MODBUS/TCP conformity test and has the "MODBUS/TCP Conformance Test Policy, Version 2.0". The measuring device has successfully passed all the test procedures carried out and is certified by the "MODBUS/TCP Conformance Test Laboratory" of the University of Michigan.



**Other standards and guidelines**

- EN 60529  
Degrees of protection by housing (IP code)
- EN 61010-1  
Protection Measures for Electrical Equipment for Measurement, Control, Regulation and Laboratory Procedures.
- EN 61326/A1 (IEC 1326)  
"Emission in accordance with Class A requirements".  
Electromagnetic compatibility (EMC requirements)
- NAMUR NE 21  
Electromagnetic compatibility (EMC) of industrial process and laboratory control equipment.
- NAMUR NE 43  
Standardization of the signal level for the breakdown information of digital transmitters with analog output signal.
- NAMUR NE 53  
Software of field devices and signal-processing devices with digital electronics

**Pressure Equipment Directive**

Measuring devices with a nominal diameter smaller than or equal to DN 25 correspond to Article 3(3) of the EC Directive 97/23/EC (Pressure Equipment Directive) and have been designed and manufactured according to good engineering practice. For larger nominal diameters, optional approvals according to Cat. II/III are available when required (depends on fluid and process pressure).

**Functional safety**

SIL -2:  
accordance IEC 61508/IEC 61511-1 (FDIS)  
"4-20 mA HART" output according to the following order code:

**Promass 80**

Promass80\*\*\*\_\*\*\*\*\*A  
 Promass80\*\*\*\_\*\*\*\*\*D  
 Promass80\*\*\*\_\*\*\*\*\*S  
 Promass80\*\*\*\_\*\*\*\*\*T  
 Promass80\*\*\*\_\*\*\*\*\*8

**Promass 83**

Promass83***_*****A	Promass83***_*****M	Promass83***_*****O
Promass83***_*****B	Promass83***_*****R	Promass83***_*****2
Promass83***_*****C	Promass83***_*****S	Promass83***_*****3
Promass83***_*****D	Promass83***_*****T	Promass83***_*****4
Promass83***_*****E	Promass83***_*****U	Promass83***_*****5
Promass83***_*****L	Promass83***_*****W	Promass83***_*****6

## Ordering information

The Endress +Hauser service organization can provide detailed ordering information and information on the order codes upon request.

## Accessories

Various accessories, which can be ordered separately from Endress+Hauser, are available for the transmitter and the sensor.

## Documentation

- Flow measurement (FA005D/06/en)
- Technical Information Promass 80F, 80M, 83F, 83M (TI053D/06/en)
- Technical Information Promass 80E, 83E (TI061D/06/en)
- Technical Information Promass 80A, 83A (TI054D/06/en)
- Technical Information Promass 80H, 83H (TI074D/06/en)
- Technical Information Promass 80I, 83I (TI075D/06/en)
- Technical Information Promass 80S, 83S (TI076D/06/en)
- Operating Instructions Promass 80 (BA057D/06/en)
- Operating Instructions Promass 80 PROFIBUS PA (BA072D/06/en)
- Operating Instructions Promass 83 (BA059D/06/en)
- Operating Instructions Promass 83 FOUNDATION Fieldbus (BA065D/06/en)
- Operating Instructions Promass 83 PROFIBUS DP/PA (BA063D/06/en)
- Operating Instructions Promass 83 MODBUS (BA107D/06/en)
- Description of Device Functions Promass 80 (BA058D/06/en)
- Description of Device Functions Promass 80 PROFIBUS PA (BA073D/06/en)
- Description of Device Functions Promass 83 (BA060D/06/en)
- Description of Device Functions Promass 83 FOUNDATION Fieldbus (BA066D/06/en)
- Description of Device Functions Promass 83, PROFIBUS DP/PA (BA064D/06/en)
- Description of Device Functions Promass 83 MODBUS (BA108D/06/en)
- Supplementary documentation on Ex-ratings: ATEX, FM, CSA
- Functional safety manual Promass 80, 83 (SD077D/06/en)

## Registered trademarks

KALREZ® and VITON®

Registered trademarks of E.I. Du Pont de Nemours & Co., Wilmington, DE, USA

TRI-CLAMP®

Registered trademark of Ladish & Co., Inc., Kenosha, WI, USA

SWAGELOK®

Registered trademark of Swagelok & Co., Solon, OH, USA

HART®

Registered trademark of HART Communication Foundation, Austin, TX, USA

PROFIBUS®

Registered trademark of the PROFIBUS User Organization, Karlsruhe, Germany

FOUNDATION™ Fieldbus

Registered trademark of the Fieldbus FOUNDATION, Austin, USA

MODBUS®

Registered trademark of the MODBUS Organization

BioConnect®

Registered trademark of NEUMO GmbH+Co. KG.

HistoROM™, S-DAT®, T-DAT™, F-CHIP®, ToF Tool - Fieldtool® Package, Fieldcheck®, Applicator®

Registered or registration-pending trademarks of Endress+Hauser Flowtec AG, Reinach, CH



---

## Instruments International

Endress+Hauser  
Instruments International AG  
Kaegenstrasse 2  
4153 Reinach  
Switzerland

Tel. +41 61 715 81 00  
Fax +41 61 715 25 00  
[www.endress.com](http://www.endress.com)  
[info@ii.endress.com](mailto:info@ii.endress.com)

**Endress+Hauser**   
People for Process Automation