



OPTIFLUX 4000 Technical Datasheet

Electromagnetic flow sensor

- Robust, fully welded construction for industrial process applications
- For demanding applications including corrosive, abrasive and high pressure
- Engineered constructions for customer specific solutions



The documentation is only complete when used in combination with the relevant documentation for the signal converter.

1	Product features	3
1.1	The all-round solution for process industries	3
1.2	Options	5
1.3	Measuring principle	7
2	Technical data	8
2.1	Technical data	8
2.2	Legal metrology	16
2.2.1	OIML R49	16
2.2.2	MID Annex III (MI-001)	18
2.2.3	Verification to MI-001 & OIML 49	20
2.2.4	OIML R117	21
2.2.5	MI-005	21
2.3	Measurement accuracy	22
2.4	Dimensions and weights	24
2.5	Pressure derating	29
2.6	Vacuum load	31
3	Installation	32
3.1	Intended use	32
3.2	General notes on installation	32
3.2.1	Vibrations	32
3.2.2	Magnetic field	32
3.3	Installation conditions	33
3.3.1	Inlet and outlet	33
3.3.2	Bends in 2 or 3 dimensions	33
3.3.3	T-section	34
3.3.4	Bends	34
3.3.5	Open discharge	35
3.3.6	Pump	35
3.3.7	Control valve	35
3.3.8	Air venting and vacuum forces	36
3.3.9	Flange deviation	37
3.3.10	Mounting position	37
3.4	Mounting	38
3.4.1	Torques and pressures	38
4	Electrical connections	41
4.1	Safety instructions	41
4.2	Grounding	41
4.3	Virtual reference for IFC 300 (C, W and F version)	43
4.4	Connection diagrams	43

1.1 The all-round solution for process industries

The **OPTIFLUX 4000** design meets the demands of a very wide range of applications in industries including the chemical, pulp & paper, water and wastewater, minerals and mining, iron, steel and metals, pharmaceuticals and oil & gas industry.

The OPTIFLUX 4000 has a field proven and unsurpassed lifetime. This is assured by the fully welded construction, full bore pipe construction, absence of moving parts and wear resistant liner materials. Even for demanding applications in harsh environments or with aggressive and abrasive media the OPTIFLUX 4000 can offer a solution.

Examples include water injection under high pressures up to 1500 bar / 21755 psi, sub-sea installations, slurries with very high solids contents, alkaline solutions and acids, up to chemical dosing, bleaching, colouring, and black liquor in the paper industry. If required, a solution beyond our standard scope can be engineered. KROHNE has in-house specialized know-how on constructions, welding and exotic materials.

For custody transfer applications, OPTIFLUX 4000 has a wide range of certifications including OIML R49 & R117, MI-001, MI-004 & MI-005.

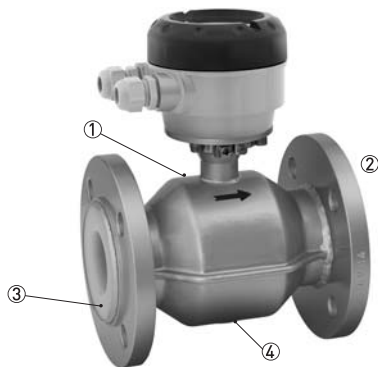

- ① Robust fully welded construction
- ② Diameter range: DN2.5...DN3000
- ③ PFA, PTFE, ETFE, PU, hard rubber and soft rubber liners
- ④ Hastelloy, titanium, tantalum, stainless steel, platinum and low noise electrodes

Highlights

- Trusted and accepted flow sensor for all process applications
- Proven in use and unsurpassed lifetime
- Large installed base – more than 400.000 units - in virtually any industry
- All welded rugged construction, to extend lifetime of equipment
- Good corrosion, erosion / abrasion resistance
- Wide choice of materials for housing & flanges including SS, Duplex, 6Mo
- Flexibility in sizes including installation lengths, special constructions, special inner diameters and inner thicknesses
- Corrosion resistant and leak tight electrodes. Specials (materials, retractable or pointed) on demand
- External coatings for offshore or subsoil installation. Optional paint specifications according to ISO 12944 – protective coating
- Reliable measurement under very demanding conditions: including high temperatures up to 180°C / 356°F, pressures up to 1500 bar / 21755 psi, high solids contents (up to 70%)
- Bi-directional flow metering
- Wide range of approvals for hazardous areas
- Compliant with requirements for custody transfer OIML R49 & R117, MI-001, MI-004 & MI-005
- No grounding rings with virtual reference option on IFC 300
- Extensive diagnostic capabilities

Industries

- Chemicals
- Pulp & Paper
- Minerals & Mining
- Oil & gas
- Iron, Steel & Metals
- Water and wastewater
- Pharmaceuticals

Applications

- For clean liquids
- For slurries and pastes with high solids content
- For abrasive and aggressive products

1.2 Options

The solution for any industry



From standard to customized

For easy ordering the standard range of the OPTIFLUX 4000 covers all popular sizes, materials and coatings. Process connections are available in EN 1092-1 (up to PN40), ASME B16.5 (up to 2500 lbs), JIS (20K) and AWWA (class D).

But KROHNE does not stop here. Our extensive engineering department is dedicated to provide solutions for all specifications not covered by our standard range. Requests for special sizes, flange connections, pressure ratings, building lengths, and materials, will always get a serious review. Whenever possible we will engineer a flow meter that fits your application.



Easy installation

Fitting the OPTIFLUX 4000 is easy with the flanged design and standard ISO insertion lengths. To further ease the operation, the OPTIFLUX 4000 can be installed without filters and straighteners. Even grounding rings are not required with the patented "Virtual Reference" option on the IFC 300 converter.



IP68

Installation in measurement chambers subject to (constant) flooding is possible with the IP68 rated version. The chambers can even be completely surpassed if the IP68 version is combined with our special subsoil coating, allowing the OPTIFLUX 4000 to be installed directly in the ground.

1.3 Measuring principle

An electrically conductive fluid flows inside an electrically insulated pipe through a magnetic field. This magnetic field is generated by a current, flowing through a pair of field coils.

Inside of the fluid, a voltage U is generated:

$$U = v * k * B * D$$

in which:

v = mean flow velocity

k = factor correcting for geometry

B = magnetic field strength

D = inner diameter of flowmeter

The signal voltage U is picked off by electrodes and is proportional to the mean flow velocity v and thus the flow rate Q . A signal converter is used to amplify the signal voltage, filter it and convert it into signals for totalizing, recording and output processing.

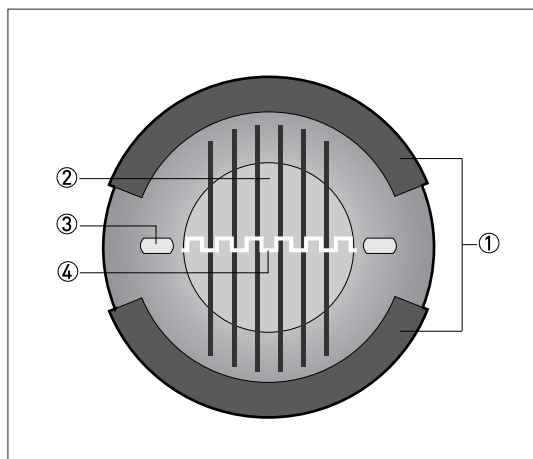

Figure 1-1: Measuring principle

- ① Field coils
- ② Magnetic field
- ③ Electrodes
- ④ Induced voltage (proportional to flow velocity)

2.1 Technical data

- *The following data is provided for general applications. If you require data that is more relevant to your specific application, please contact us or your local sales office.*
- *Additional information (certificates, special tools, software,...) and complete product documentation can be downloaded free of charge from the website (Downloadcenter).*

Measuring system

Measuring principle	Faraday's law
Application range	Electrically conductive fluids
Measured value	
Primary measured value	Flow velocity
Secondary measured value	Volume flow

Design

Features	Fully welded maintenance-free flow sensor.
	Flange version with full bore flow sensor.
	Standard as well as higher pressure ratings.
	Broad range of nominal sizes.
	Industry specific insertion lengths.
Modular construction	The measurement system consists of a flow sensor and a signal converter. It is available as compact and as separate version.
Compact version	With signal converter IFC 050: OPTIFLUX 4050 C
	With signal converter IFC 100: OPTIFLUX 4100 C
	With signal converter IFC 300: OPTIFLUX 4300 C
Remote version	In wall (W) mount version with signal converter IFC 050: OPTIFLUX 4050 W
	In wall (W) mount version with signal converter IFC 100: OPTIFLUX 4100 W
	In field (F), wall (W) or rack (R) mount version with signal converter IFC 300: OPTIFLUX 4300 F, W or R
Nominal diameter	With signal converter IFC 050: DN2.5... 1200 / 1/10...48"
	With signal converter IFC 100: DN2.5...1200 / 1/10...48"
	With signal converter IFC 300: DN2.5...3000 / 1/10...120"

Measuring accuracy

Maximum measuring error	Depending on signal converter and DN size.	
	IFC 050: down to 0.5% of the measured value ± 1 mm/s	
	IFC 100: down to 0.3% of the measured value ± 1 mm/s	
	IFC 300: down to 0.2% of the measured value ± 1 mm/s	
	Optionally: optimised accuracy for IFC 050 and IFC 100. For more details on optimised accuracy, see the concerning signal converter documentation.	
	The additional typical measuring deviation for the current output is $\pm 10 \mu\text{A}$.	
	The maximum measuring error depends on the installation conditions.	
	For detailed information refer to <i>Measurement accuracy</i> on page 22.	
Repeatability	$\pm 0.1\%$ of MV, minimum 1 mm/s	
Calibration / Verification	Standard:	
	2 point calibration by direct volume comparison.	
	Optional:	
	Verification to Measurement Instrument Directive (MID), Annex III (MI-001). Standard: Verification at Ratio (Q3/Q1) = 80, Q3 ≥ 2 m/s Optional: Verification at Ratio (Q3/Q1) > 80 on request (Only in combination with signal converter IFC 300)	
Long term stability	$\pm 0.1\%$ of MV	
Special calibration	On request.	
MID Annex III (MI-001) (Directive 2014/32/EU)	EC-Type examination certificate to MID Annex III (MI-001)	
	(Only in combination with signal converter IFC 300)	
	Diameter range: DN25...1600	
	Forward and reverse (bi-directional) flow	
	Liquid temperature range: + 0.1°C / +50°C	
	For detailed information refer to <i>Legal metrology</i> on page 16.	
OIML R49	Certificate of conformity to OIML R49	
	(Only in combination with signal converter IFC 300)	
	Diameter range	Class 1: DN80...500 Class 2: DN25...50
	Forward and reverse (bi-directional) flow	
	Liquid temperature range: +0.1°C / 50°C	
	For detailed information refer to <i>Legal metrology</i> on page 16.	

Operating conditions

Temperature	
For Ex versions different temperatures are valid. Please check the relevant Ex documentation for details.	
Process temperature	PTFE / PFA: -40...+180°C / -40...+356°F for remote versions
	PTFE / PFA: -40...+140°C / -40...+284°F for IFC 300 compact versions
	PTFE / PFA: -40...+120°C / -40...+248°F for IFC 050 and IFC 100 compact versions
	ETFE: -40...+120°C / -40...+248°F
	Hard rubber: -5...+80°C / 23...+176°F
	Soft rubber: -5...+60°C / 23...+140°F
	PU: -5...+65°C / 23...+149°F
	For more information about temperatures see the temperature table in the manual.
Ambient temperature	Standard (with aluminum signal converter housing): -40...+65°C / -40...+149°F
	Protect the electronics against self-heating with ambient temperatures above +55°C / +131°F.
	Option (with stainless steel signal converter housing): low temperate carbon steel flanges or stainless steel flanges.
	-40...+55°C / -40...+130°F
Storage temperature	-50...+70°C / -58...+158°F
Measuring range	-12...+12 m/s / -40...+40 ft/s
Pressure	
EN 1092-1	DN2200...3000: PN2.5
	DN1200...2000: PN6
	DN200...1000: PN10
	DN65 and DN100...150: PN16
	DN2.5...50 and DN80: PN40
	Other pressures on request.
ASME B16.5	1/10...40": 150 lb RF
	Other pressures on request.
JIS	DN50...1000 / 2..40": 10 K
	DN2.5...40 / 1/10...1½" : 20 K
	Other pressures on request.
AWWA	DN700...1800 / 28...72" class D
	Other pressures on request.
Vacuum load	For detailed information refer to <i>Vacuum load</i> on page 31.
Pressure loss	Negligible

Chemical properties	
Physical condition	Electrically conductive liquids
Electrical conductivity	Water: $\geq 20 \mu\text{S/cm}$
	Standard: $\geq 1 \mu\text{S/cm}$
Permissible gas content (volume)	IFC 050: $\leq 3\%$
	IFC 100: $\leq 5\%$
	IFC 300: $\leq 5\%$
Permissible solid content (volume)	IFC 050: $\leq 10\%$
	IFC 100: $\leq 10\%$
	IFC 300: $\leq 70\%$

Installation conditions

Installation	Assure that the flow sensor is always fully filled.
	For detailed information refer to <i>Installation</i> on page 32.
Flow direction	Forward and reverse.
	Arrow on flow sensor indicates positive flow direction.
Inlet run	$\geq 5 \text{ DN}$
Outlet run	$\geq 2 \text{ DN}$
Dimensions and weights	For detailed information refer to <i>Dimensions and weights</i> on page 24.

Materials

Flow sensor housing	DN2.5...15 / 1/10...1/2": with PFA liner, stainless steel 1.4408
	DN10...20 / 3/8... 3/4": with PTFE liner; Duplex
	DN25...3000 / 1...120": sheet steel
	Other materials on request.
Measuring tube	Austenitic stainless steel
Flanges	Standard: carbon steel
	Other materials on request.
Liner	Standard
	DN2.5...15 / 1/10...1/2": PFA
	DN20 / 3/4": PTFE
	DN25...150 / 1...6": PFA
	DN200...1800 / 8...72": ETFE
	Option
	DN10 - DN15 / 3/8 - 1/2": PTFE
	DN200...600 / 8...24": PTFE
	DN200...1800 / 8...72": PU
	DN200...3000 / 8...120": Hard rubber (Ex only)
	DN50...600 / 2...24": Soft rubber
	Other materials on request.
Protective coating	On exterior of the meter: flanges, housing, signal converter (compact version) and/or connection box (field version)
	Standard coating
	Option: off shore coating
Connection box	Only for remote versions
	Standard: die-cast aluminum
	Option: stainless steel
Measuring electrodes	Standard: Hastelloy® C
	Option: platinum, stainless steel, titanium, tantalum, low noise (coated electrodes)
	Option: conductive rubber (only in combination with soft rubber liner)
	Other materials on request.
Grounding rings	Standard: stainless steel
	Option: Hastelloy® C, titanium, tantalum
	Grounding rings can be omitted with virtual reference option for the signal converter IFC 300.
Reference electrode (optional)	Standard: Hastelloy® C
	Option: platinum, stainless steel, titanium, tantalum, low noise
	Other materials on request.

Process connections

Flange	
EN 1092-1	DN2.5...3000 in PN2.5...40
ASME	1/10...120" in 150...2500 lb RF
JIS	DN2.5...1000 in JIS 10...20 K
Design of gasket surface	EN 1092-1, ASME, JIS; RF
	AWWA: FF
	Other sizes or pressure ratings on request.

Electrical connections

For full detail refer to the relevant documentation of the signal converter.	
Signal cable (remote versions only)	
Type A (DS)	In combination with the signal converter IFC 050, IFC 100 and IFC 300
	Standard cable, double shielded. Max. length: 600 m / 1968 ft (dep. on electrical conductivity and flow sensor)
Type B (BTS)	Only in combination with the signal converter IFC 300
	Optional cable, triple shielded. Max. length: 600 m / 1968 ft (dep. on electrical conductivity and flow sensor)
I/O	For full details of I/O options, including data streams and protocols, see technical datasheet of the relevant converter converter.

Approvals and certificates

CE	
This device fulfils the statutory requirements of the EU directives. The manufacturer certifies successful testing of the product by applying the CE mark.	
	For full information of the EU directive & standards and the approved certifications; please refer to the EU Declaration of Conformity or the website of the manufacturer.
Hazardous areas	
ATEX	Please check the relevant Ex documentation for details.
	Compact version with signal converter IFC 050 C : II 2 GD
	Compact version with signal converter IFC 100 C: II 2(1)G, IIC T4 Gb and II 2(1)D, IIIC T180°C Db
	Compact version with signal converter IFC 300 C: II 2(1)G, IIC T6...T3 Gb and II 2D, IIIC T150°C Db
	Remote version: II 2G, IIC T6...T3 Gb and II 2D, IIIC T180°C Db
FM	In combination with signal converter IFC 100:
	Class I, Div 2, groups A, B, C and D; T4
	In combination with signal converter IFC 300:
	Class I, Div 2, groups A, B, C and D; T6
	Class II, Div 2, groups F and G
Class III, Div 2, T6	
CSA	In combination with signal converter IFC 300:
	Class I, Div 2, groups A, B, C and D
	Class II, Div 2, groups F and G; T6
IECEx	Compact version with signal converter IFC 100:
	IIC T4 Gb and IIIC T180°C Db
	Compact version with signal converter IFC 300:
	IIC T6...T3 Gb and IIIC T150°C Db
	Remote version with signal converter IFC 300:
IIC T6...T3 Gb and IIIC T180°C Db	
NEPSI	Compact version with signal converter IFC 100 - IFC 300: or remote version IFC 300 F:
	Ex e ia mb IIC T6...T3 Gb / Ex d e ia mb IIC T4 Gb / Ex d e ia mb [ia Ga] IIC T6...T3 Gb
	Ex d e ia IIC T6...T3 Gb / Ex e ia mb IIC T4 Gb / Ex d e ia [ia Ga] IIC T6...T3 Gb
	Ex e q ia IIC T6...T3 Gb / Ex e ia mb q IIC T3/T4 Gb / Ex d e ia q [ia Ga] IIC T6...T3 Gb
	Ex e ia IIC T6...T3 Gb / Ex d e ia [ia Ga] IIC T6...T3 Gb

Other approvals and standards	
Custody transfer	Standard: without verification
	Only in combination with signal converter IFC 300.
	For diameters: DN25...1800 (other diameters on request)
	Cold water
	MID Directive 2014/32/EU MID Annex III (MI-001) type examination certificate
	OIML R49 certificate of conformity
	Conformity with ISO 4064 and EN 14154
	Liquids other than water
	For diameters DN25...DN500
	MID Directive 2014/32/EU MID Annex VII (MI-005) type examination certificate
OIML R117 certificate of conformity	
Hygiene	PFA liner is FDA compliant.
BSE/TSE	Bovine spongiform encephalopathy / Transmissible spongiform encephalopathy Declaration on request
Protection category acc. to IEC 60529	Standard:
	IP66/67, NEMA 4/4X/6
	Option:
	IP68, NEMA 6P IP68 is only available for separate design and with a stainless steel connection box.
Protective coating	Standard; ISO 12944-2: C3 medium / C4 high Off shore coating; ISO 12944-2: C5I high / C5M high
Vibration resistance	IEC 60068-2-64
Random vibration test	IEC 60068-2-34
Shock test	IEC 60068-2-27

2.2 Legal metrology

OIML R49, R117 and MID Annex MI-001, MI-005 is **only** available in combination with the signal converter IFC 300.

2.2.1 OIML R49

The OPTIFLUX 4300 has a certificate of conformity with the international recommendation OIML R49 (edition). The certificate has been issued by NMI (Dutch board of weight and measures).

The OIML R49 recommendation concerns water meters intended for the metering of cold potable and hot water. The measuring range of the flowmeter is determined by Q3 (nominal flow rate) and R (ratio).

The OPTIFLUX 4300 meets the requirements for water meters of accuracy class 1 and 2.

$$Q1 = Q3 / R$$

$$Q2 = Q1 * 1.6$$

$$Q3 = Q1 * R$$

$$Q4 = Q3 * 1.25$$



Figure 2-1: ISO flow rates added to figure as comparison towards OIML

X: Flow rate

Y [%]: Maximum measuring error

① ± 3% for class 1, ± 5% for class 2 devices

② ± 1% for class 1, ± 2% for class 2 devices

OIML R49 Class 1

DN	Span (R)	Flow rate [m ³ /h]			
		Minimum Q1	Transitional Q2	Permanent Q3	Overload Q4
65	630	0.1587	0.254	100	125
80	630	0.254	0.4063	160	200
100	630	0.3968	0.6349	250	312.5
125	630	0.6349	1.0159	400	500
150	630	0.6349	1.0159	400	500
200	1000	1.0	1.6	1000	1250
250	1000	1.6	2.56	1600	2000
300	1000	2.5	4.0	2500	3125
350	500	5.0	8.0	2500	3125
400	500	8.0	12.8	4000	5000
450	500	8.0	12.8	4000	5000
500	500	12.6	20.16	6300	7875
600	160	39.375	63	6300	7875
700	80	125	200	10000	12500
800	80	125	200	10000	12500
900	80	200	320	16000	20000
1000	80	200	320	16000	20000
1100	80	200	320	16000	20000
1200	80	200	320	16000	20000
1300	80	312.5	500	25000	31250
1400	80	312.5	500	25000	31250
1500	80	312.5	500	25000	31250
1600	80	312.5	500	25000	31250
1800	50	500	800	25000	31250

OIML R49 Class 2

DN	Span (R)	Flow rate [m ³ /h]			
		Minimum Q1	Transitional Q2	Permanent Q3	Overload Q4
25	400	0.040	0.064	16	20
32	400	0.0625	0.10	25	31.25
40	400	0.0625	0.10	25	31.25
50	400	0.10	0.16	40	50

For DN65 to DN1600; same values (DN, R, Q1, Q2, Q3, Q4) as for OIML R49 class 1 are applicable.

2.2.2 MID Annex III (MI-001)

All new designs of flow meters that are to be used for legal purposes in Europe require certification under the Measurement Instrument Directive (MID) 2014/32/EU Annex III (MI-001). Annex MI-001 of the MID applies to water meters intended for the measurement of volume of clean, cold or heated water in residential, commercial and light industrial use. An EC-type examination certificate is valid in all countries of the European Union.

The OPTIFLUX 4300 has an EC-type examination certificate and can be verified to the MID Annex III (MI-001) for water meters with diameter DN25...DN1800.

The conformity assessment procedure followed for OPTIFLUX 4300 is Module B (Type Examination) and Module D (Quality Assurance of the Production Process).

The maximum permissible error on volumes delivered between Q2 (transitional) flow rate and Q4 (overload) flow rate is $\pm 2\%$.

The maximum permissible error on volumes delivered between Q1 (minimum) flow rate and Q2 (transitional) flow rate is $\pm 5\%$.

$$Q1 = Q3 / R$$

$$Q2 = Q1 * 1.6$$

$$Q3 = Q1 * R$$

$$Q4 = Q3 * 1.25$$

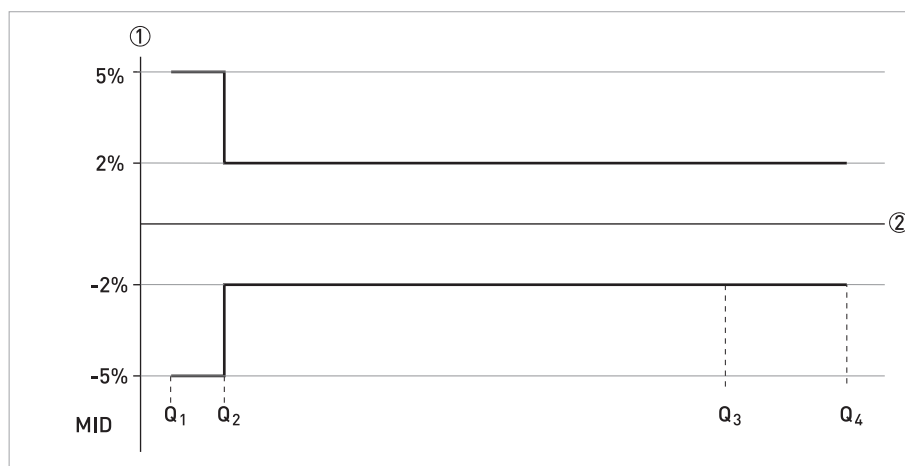

Figure 2-2: ISO flow rates added to figure as comparison towards MID

X: Flow rate

Y [%]: Maximum measuring error

MI-001 certified flow characteristics

DN	Span (R) Q3 / Q1	Flow rate [m ³ /h]			
		Minimum Q1	Transitional Q2	Permanent Q3	Overload Q4
25	400	0.04	0.064	16	20
32	400	0.0625	0.10	25	31.25
40	400	0.0625	0.10	25	31.25
50	400	0.10	0.16	40	50
65	625	0.1587	0.254	100	125
80	640	0.254	0.4063	160	200
100	625	0.3968	0.6349	250	312.5
125	667	0.6349	1.0159	400	500
150	667	0.6349	1.0159	400	500
200	1000	1.0	1.6	1000	1250
250	1000	1.6	2.56	1600	2000
300	1000	2.5	4.0	2500	3125
350	500	5.0	8.0	2500	3125
400	500	8.0	12.8	4000	5000
450	500	8.0	12.8	4000	5000
500	500	12.6	20.16	6300	7875
600	160	39.375	63	6300	7875
700	80	125	200	10000	12500
800	80	125	200	10000	12500
900	80	200	320	16000	20000
1000	80	200	320	16000	20000
1100	80	200	320	16000	20000
1200	80	200	320	16000	20000
1300	80	312.5	500	25000	31250
1400	80	312.5	500	25000	31250
1500	80	312.5	500	25000	31250
1600	80	312.5	500	25000	31250
1800	59	500	800	25000	31250

2.2.3 Verification to MI-001 & OIML 49

Verification to MI-001 and to OIML R49 class 2 is carried out at the following values for R, Q1, Q2 and Q3. Verification to OIML R49 class 1 and at other values for R and Q3 available on request.

Verification to MID Annex III (MI-001)

DN	Span (R) Q3 / Q1	Flow rate [m ³ /h]		
		Q1	Q2	Q3
25	80	0.05	0.08	4
32	80	0.125	0.20	10
40	80	0.125	0.20	10
50	80	0.2	0.32	16
65	80	0.3125	0.50	25
80	80	0.5	0.7875	40
100	80	0.7875	1.26	63
125	80	1.250	2.00	100
150	80	2.0	3.2	160
200	80	3.125	5.0	250
250	80	5.0	8.0	400
300	80	7.875	12.6	630
350	80	20	32	1600
400	80	31.25	50	2500
450	80	31.25	50	2500
500	80	50.0	80	4000
600	80	78.75	126	6300
700	50	125	200	10000
800	50	125	200	10000
900	50	200	512	16000
1000	50	200	512	16000
1100	50	320	512	16000
1200	50	320	512	16000
1400	50	500	800	25000
1600	50	500	500	25000
1800	50	500	800	25000

2.2.4 OIML R117

OIML R117

DN	Qmax [m ³ /h]	Qmin [m ³ /h]	MMQ[m ³]	MPA Class	Accuracy [%]
15	5.4	0.27	0.002	0.5	0.3
25	20	1	0.2	0.3	0.2
50	50	2.5	0.5	0.3	0.2
80	200	10	2	0.3	0.2
100	312.5	15.6	2	0.3	0.2
150	500	25	5	0.3	0.2
250	2000	100	20	0.3	0.2
500	7875	787.5	100	0.3	0.2

2.2.5 MI-005

MI-005

DN	Qmax [m ³ /h]	Qmin [m ³ /h]	MMQ[m ³]	Accuracy Class
15	5.4	0.27	0.002	0.5
25	20	1.0	0.01	0.3
32	31.3	1.6	0.5	0.3
40	31.3	1.6	0.5	0.3
50	50	2.5	0.5	0.3
65	125	6.3	2	0.3
80	200	10	2	0.3
100	312.5	15.6	2	0.3
125	500	25	5	0.3
150	500	25	5	0.3
200	1250	62.5	10	0.3
250	2000	100	20	0.3
300	3125	156	50	0.3
350	3125	156	50	0.3
400	5000	250	50	0.3
450	5000	250	50	0.3
500	7875	787.5	100	0.3

2.3 Measurement accuracy

Every electromagnetic flowmeter is calibrated by direct volume comparison. The wet calibration validates the performance of the flowmeter under reference conditions against accuracy limits.

The accuracy limits of electromagnetic flowmeters are typically the result of the combined effect of linearity, zero point stability and calibration uncertainty.

Reference conditions

- Medium: water
- Temperature: +5...+35°C / +41...+95°F
- Operating pressure: 0.1...5 barg / 1.5...72.5 psig
- Inlet section: ≥ 5 DN
- Outlet section: ≥ 2 DN

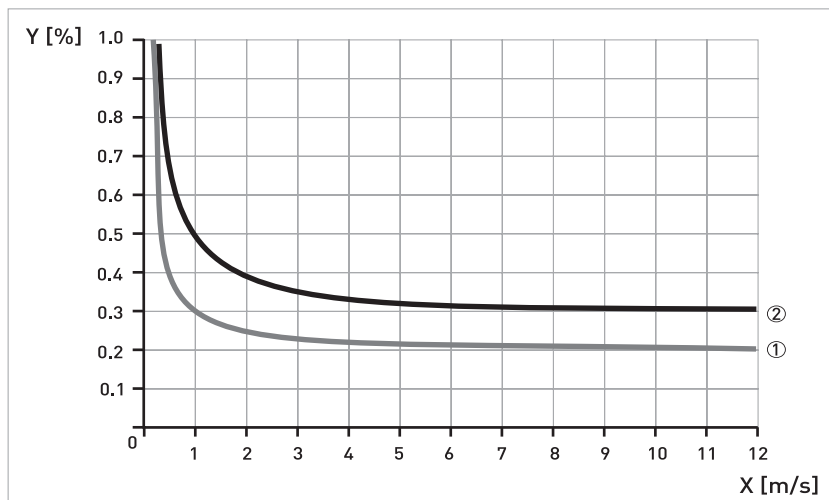

Figure 2-3: Flow velocity vs. accuracy
 X [m/s] : flow velocity
 Y [%]: deviation from the actual measured value (mv)

Accuracy

Flow sensor diameter	Signal converter type	Accuracy	Curve
DN2.5...6 / 1/10...1/4"	IFC 300	± 0.3% of mv + 2 mm/s	②
DN10...1600 / 3/8...64"	IFC 300	± 0.2% of mv + 1 mm/s	①
DN1800...3000 / > 64"	IFC 300	± 0.3% of mv + 2 mm/s	②

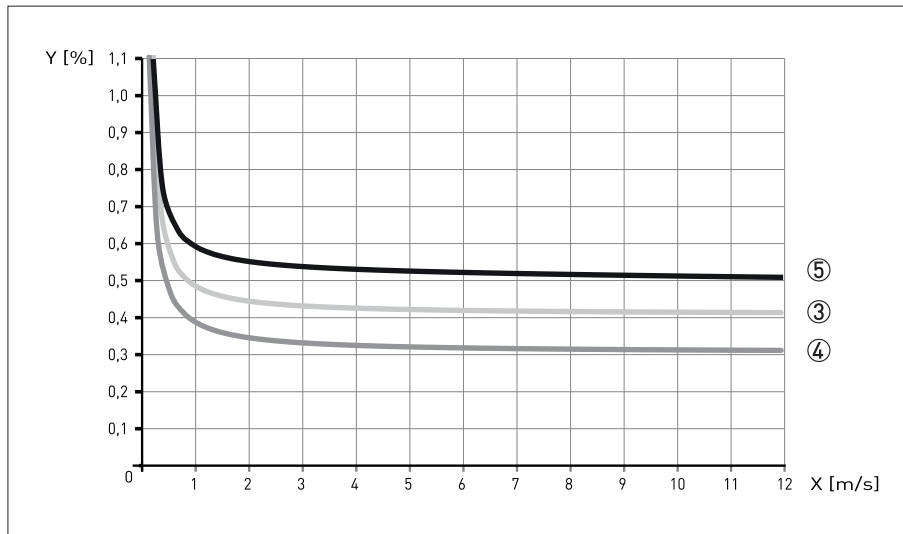

Figure 2-4: Flow velocity vs. accuracy

X [m/s] : flow velocity

Y [%]: deviation from the actual measured value (mv)

Accuracy

Flow sensor diameter	Signal converter type	Accuracy	Curve
DN2.5...6 / $1/10$... $1/4$ "	IFC 100	$\pm 0.4\%$ of mv + 1 mm/s	③
DN10...1200 / $3/8$...48"	IFC 100	$\pm 0.3\%$ of mv + 1 mm/s	④
DN2.5...1200 / $1/10$...48"	IFC 050	$\pm 0.5\%$ of mv + 1 mm/s	⑤

*Optionally for IFC 050 and IFC 100; extended calibration at 2 points for optimised accuracy.
For more details on optimised accuracy, see the concerning signal converter documentation*

2.4 Dimensions and weights

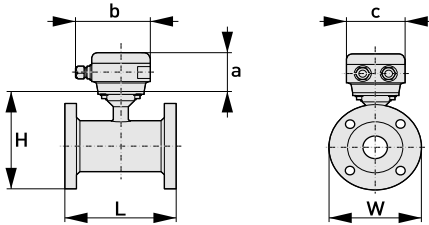
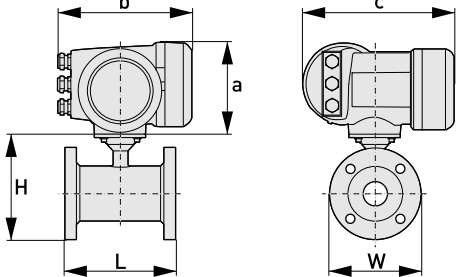
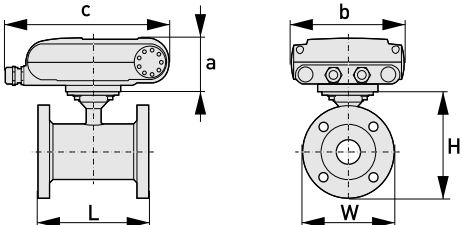
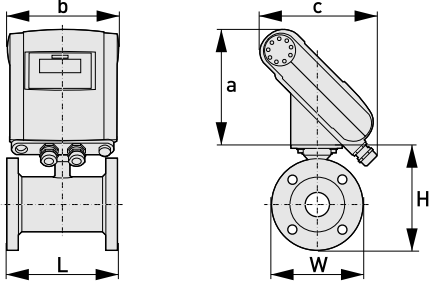
<p>Remote version</p>		<p>a = 88 mm / 3.5"</p> <p>b = 139 mm / 5.5" ①</p> <p>c = 106 mm / 4.2"</p> <p>Total height = H + a</p>
<p>Compact version with: IFC 300</p>		<p>a = 155 mm / 6.1"</p> <p>b = 230 mm / 9.1" ①</p> <p>c = 260 mm / 10.2"</p> <p>Total height = H + a</p>
<p>Compact version with: IFC 100 (0°)</p>		<p>a = 82 mm / 3.2"</p> <p>b = 161 mm / 6.3"</p> <p>c = 257 mm / 10.1" ①</p> <p>Total height = H + a</p>
<p>Compact version with: IFC 100 (45°)</p>		<p>a = 186 mm / 7.3"</p> <p>b = 161 mm / 6.3"</p> <p>c = 184 mm / 7.3" ①</p> <p>Total height = H + a</p>

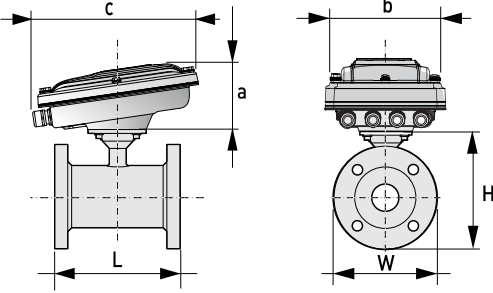
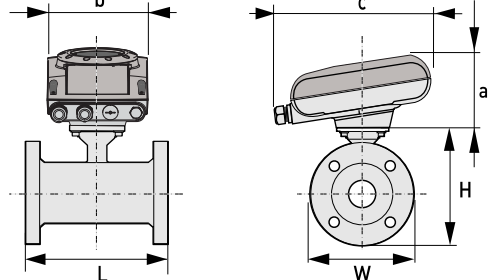
Compact version with stainless steel IFC 100 (10°)		a = 100 mm / 4" b = 187 mm / 7.36" ① c = 270 mm / 10.63" Total height = H + a
Compact version with: IFC 050 (10°)		a = 100mm / 4" b = 157 mm / 6.18" ① c = 260 mm / 10.24" Total height = H + a

① The value may vary depending on the used cable glands.

- All data given in the following tables are based on standard versions of the flow sensor only.
- Especially for smaller nominal sizes of the flow sensor, the signal converter can be bigger than the sensor.
- Note that for other pressure ratings than mentioned, the dimensions may be different.
- For full information on signal converter dimensions see relevant documentation.

EN 1092-1

Nominal size		Dimensions [mm]				Approximately weight [kg]
DN	PN [bar]	L		H	W	
		DIN	ISO 13359			
2.5...6	40	130	-	142	90	3
10	40	130 ①	-	106	90	6
15	40	130 ①	200	106	95	6
20	40	150	200	158	105	7
25	40	150	200	140	115	4
32	40	150	200	157	140	5
40	40	150	200	166	150	5
50	40	200	200	186	165	9
65	16	200	200	200	185	9
80	40	200	200	209	200	12
100	16	250	250	237	220	15
125	16	250	250	266	250	19
150	16	300	300	300	285	27
200	10	350	350	361	340	34
250	10	400	450	408	395	48
300	10	500	500	458	445	58
350	10	500	550	510	505	78
400	10	600	600	568	565	101
450	10	600	-	618	615	111
500	10	600	-	671	670	130
600	10	600	-	781	780	165
700	10	700	-	898	895	248
800	10	800	-	1012	1015	331
900	10	900	-	1114	1115	430
1000	10	1000	-	1225	1230	507
1200	6	1200	-	1417	1405	555
1400	6	1400	-	1619	1630	765
1600	6	1600	-	1819	1830	1035
1800	6	1800	-	2027	2045	1470
2000	6	2000	-	2259	2265	1860

① 150 mm for construction according to order code VN03 (contact sales)

150 lb flanges

Nominal size		Dimensions [inch]				Approximately weight [lb]
ASME	PN [psi]	L		H	W	
		DIN	ISO 13359			
1/10"	284	5.12	-	5.59	3.50	6
1/6"	284	5.12	-	5.59	3.50	6
1/4"	284	5.12	-	5.59	3.50	6
3/8"	284	5.12 ①	-	5.08	3.50	12
1/2"	284	5.12 ①	7.87	5.08	3.50	12
3/4"	284	5.91	7.87	5.28	3.88	18
1"	284	5.91	7.87	5.39	4.25	7
1 1/4"	284	5.91	7.87	5.98	4.62	7
1 1/2"	284	5.91	7.87	6.10	5.00	11
2"	284	7.87	7.87	7.05	5.98	18
2 1/2"	284	7.87	7.87	7.72	7.00	24
3"	284	7.87	7.87	8.03	7.50	26
4"	284	9.84	9.84	9.49	9.00	40
5"	284	9.84	9.84	10.55	10.0	49
6"	284	11.81	11.81	11.69	11.0	64
8"	284	13.78	13.78	14.25	13.5	95
10"	284	15.75	17.71	16.3	16.0	143
12"	284	19.69	19.69	18.78	19.0	207
14"	284	27.56	21.65	20.67	21.0	284
16"	284	31.50	23.62	22.95	23.5	364
18"	284	31.50	-	24.72	25.0	410
20"	284	31.50	-	26.97	27.5	492
24"	284	31.50	-	31.38	32.0	675

① 5.91" for construction according to order code VN03 (contact sales)

- Pressures at 20°C / 68°F.
- For higher temperatures, the pressure and temperature ratings are as per ASME B16.5.

300 lb flanges

Nominal size		Dimensions [inch]				Approximately weight [lb]
ASME	PN [psi]	L		H	W	
		DIN	ISO 13359			
1/10"	741	5.12	--	5.59	3.75	6
1/6"	741	5.12		5.59	3.75	6
1/4"	741	5.12	-	5.59	3.75	6
3/8"	741	5.12 ①	-	5.24	3.75	15
1/2"	741	5.12 ①	7.87	5.24	3.75	15
3/4"	741	5.91	7.87	5.67	4.62	20
1"	741	5.91	7.87	5.71	4.87	11
1 1/2"	741	7.87	7.87	6.65	6.13	13
2"	741	9.84	7.87	7.32	6.50	22
3"	741	9.84	7.87	8.43	8.25	31
4"	741	11.81	9.84	10.00	10.0	44
6"	741	12.60	11.81	12.44	12.5	73
8"	741	15.75	13.78	15.04	15.0	157
10"	741	19.69	17.71	17.05	17.5	247
12"	741	23.62	-	20.00	20.5	375
14"	741	27.56	-	21.65	23.0	474
16"	741	31.50	-	23.98	25.5	639
20"	741	31.50	-	28.46	30.5	937
24"	741	31.50	-	33.39	36.0	1345

① 5.91" for construction according to order code VN03 (contact sales)

- Pressures at 20°C / 68°F.
- For higher temperatures, the pressure and temperature ratings are as per ASME B16.5.

2.5 Pressure derating

The graphs below refer to the maximum pressure as a function of the temperature for the flanges of the flowmeter (per specified flange material).

Please note that the specified values only refer to the flanges. The maximum value for the flowmeter can further be limited by the maximum value for other materials (i.e. the liner)

For A = Carbon steel A 105 & B = Stainless steel 316L

X/Y axes in all graphs; X = Temperature in [°C] / Y = Pressure in [bar]
x/y axes in all graphs; x = Temperature in [°F] / y = Pressure in [psi]

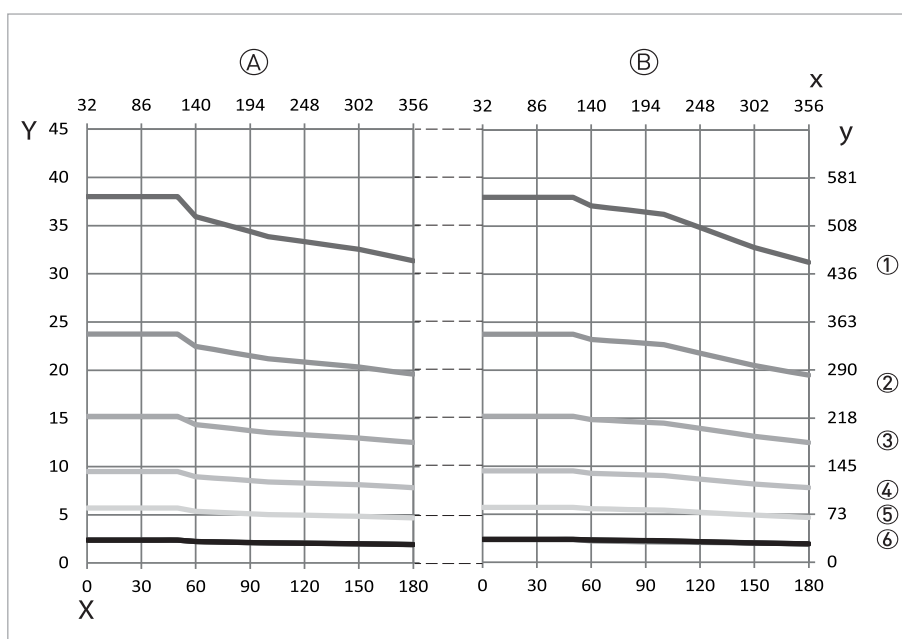

Figure 2-5: Pressure derating; EN 1092-1

- ① PN 40
- ② PN 25
- ③ PN 16
- ④ PN 10
- ⑤ PN 6
- ⑥ PN 2.5

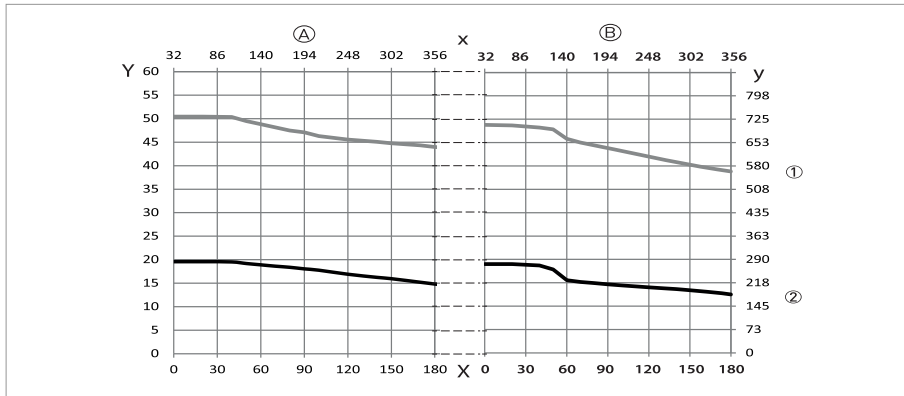

Figure 2-6: Pressure derating; ANSI B16.5

- ① 300 lbs
- ② 150 lbs

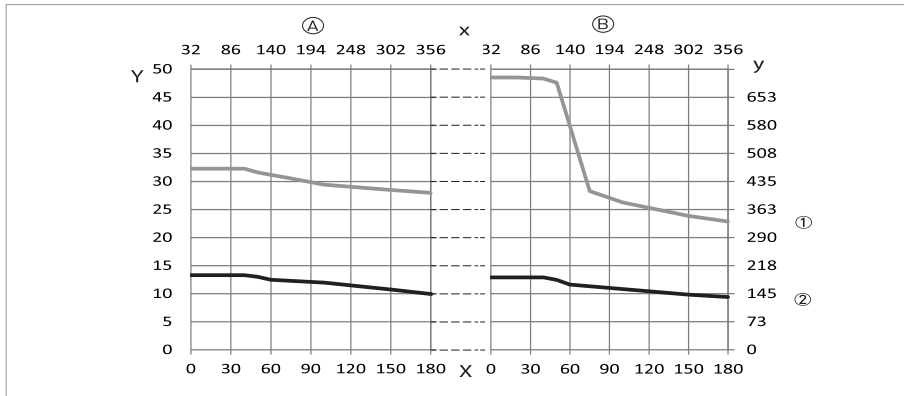

Figure 2-7: Pressure derating; JIS B2220

- ① 20K
- ② 10K

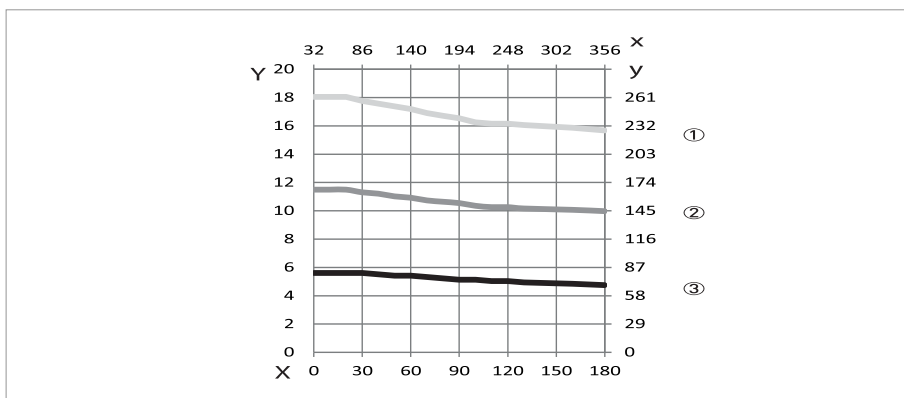

Figure 2-8: Pressure derating; AWWA C207

- ① Class D1 [4...12"]
- ② Class D2 [>12"]
- ③ Class B

2.6 Vacuum load

Diameter	Max. pressure	Vacuum load in mbar abs. at a process temperature of								
[mm]	[bar]	40°C	60°C	70°C	80°C	90°C	100°C	120°C	140°C	180°C
Liner in PTFE										
DN10...20	50	0	0	0	0	0	0	500	750	1000
DN200...300	50	500	750	1000	1000	1000	1000	1000	1000	1000
DN350...600	50	800	1000	1000	1000	1000	1000	1000	1000	1000
Liner in PFA										
DN2.5...150	50	0	0	0	0	0	0	0	0	0
Liner in ETFE										
DN200...2000	150	100	100	100	100	100	100	100	-	-
Liner in Hard rubber										
DN200...300	150	250	400	400	400	-	-	-	-	-
DN350...3000	150	500	600	600	600	-	-	-	-	-
Liner in PU										
DN200...1800	1500	500	600	-	-	-	-	-	-	-
Liner in Soft rubber										
DN50..600	40	1000	1000	-	-	-	-	-	-	-

Diameter	Max. pressure	Vacuum load in psia at a process temperature of								
[inch]	[psi]	104°F	140°F	158°F	176°F	194°F	212°F	248°F	284°F	356°F
Liner in PTFE										
3/8...3/4"	725	0	0	0	0	0	0	7.3	10.9	14.5
8...12"	725	7.3	10.9	14.5	14.5	14.5	14.5	14.5	14.5	14.5
14...24"	725	11.6	14.5	14.5	14.5	14.5	14.5	14.5	14.5	14.5
Liner in PFA										
1/10...6"	725	0	0	0	0	0	0	0	0	0
Liner in ETFE										
8...72"	2176	1.5	1.5	1.5	1.5	1.5	1.5	1.5	-	-
Liner in Hard rubber										
8...12"	2176	3.6	5.8	5.8	5.8	-	-	-	-	-
14...120"	2176	7.3	8.7	8.7	8.7	-	-	-	-	-
8...72"	21756	7.3	8.7	-	-	-	-	-	-	-
Liner in Soft rubber										
2..24"	580	14.5	14.5	-	-	-	-	-	-	-

3.1 Intended use

Responsibility for the use of the measuring devices with regard to suitability, intended use and corrosion resistance of the used materials against the measured fluid lies solely with the operator.

The manufacturer is not liable for any damage resulting from improper use or use for other than the intended purpose.

The OPTIFLUX 4000 electromagnetic flowmeter is designed exclusively to measure the flow of electrically conductive, liquid media.

3.2 General notes on installation

Inspect the packaging carefully for damages or signs of rough handling. Report damage to the carrier and to the local office of the manufacturer.

Do a check of the packing list to make sure that you have all the elements given in the order.

Look at the device nameplate to ensure that the device is delivered according to your order. Check for the correct supply voltage printed on the nameplate.

3.2.1 Vibrations

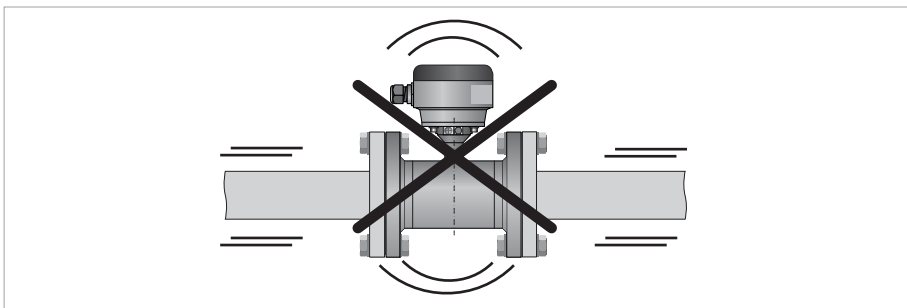

Figure 3-1: Avoid vibrations

3.2.2 Magnetic field

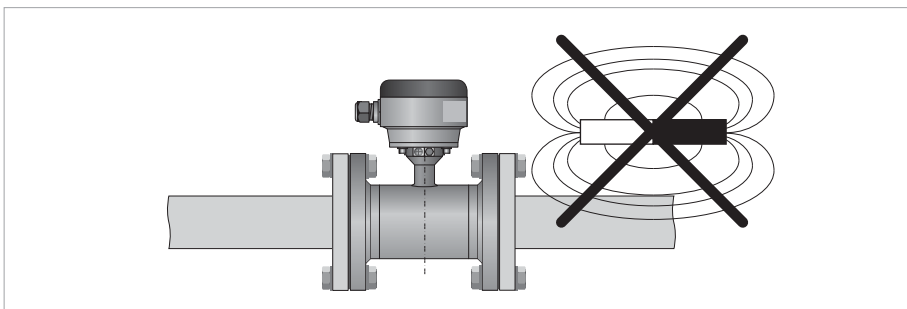

Figure 3-2: Avoid magnetic field

Keep at least 5 DN distance between electromagnetic flow sensors.

3.3 Installation conditions

3.3.1 Inlet and outlet

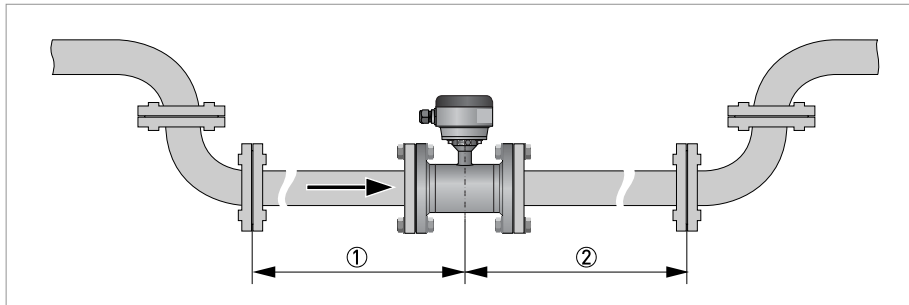

Figure 3-3: Recommended inlet and outlet

- ① Refer to chapter "Bends in 2 or 3 dimensions"
- ② ≥ 2 DN

Sensors of type VN02 up to DN10:

The inlet and outlet sections are enclosed inside the sensor.

3.3.2 Bends in 2 or 3 dimensions

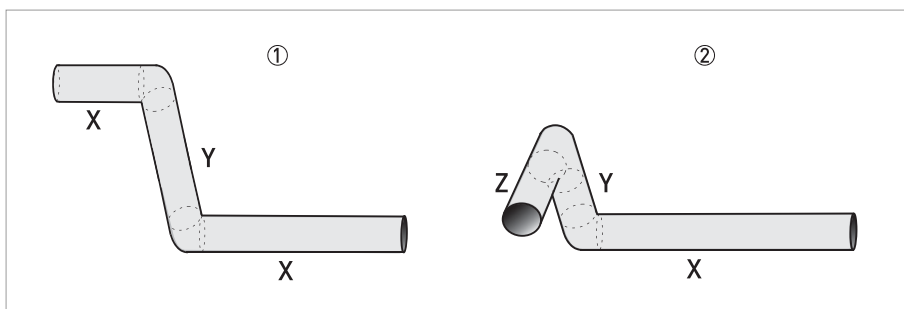

Figure 3-4: 2 and/or 3 dimensional bends upstream of the flowmeter

- ① 2 dimensions = X/Y
- ② 3 dimensions = X/Y/Z

Inlet length: using bends in 2 dimensions: ≥ 5 DN; when having bends in 3 dimensions: ≥ 10 DN

*2 dimensional bends occur in a vertical **or** horizontal plane (X/Y) only, while 3 dimensional bends occur in both vertical **and** horizontal plane (X/Y/Z).*

3.3.3 T-section

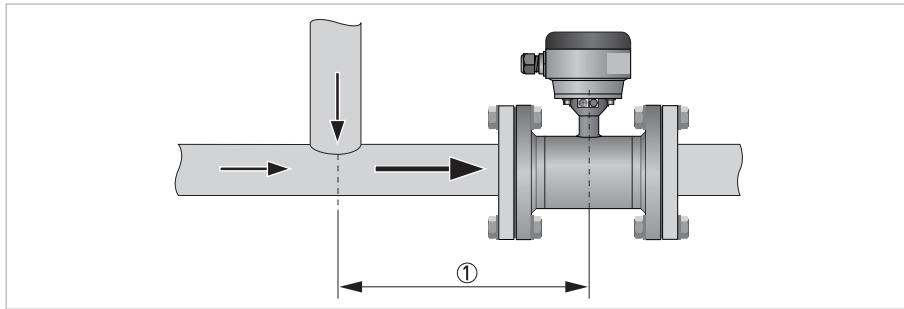

Figure 3-5: Distance behind a T-section

① ≥ 10 DN

3.3.4 Bends

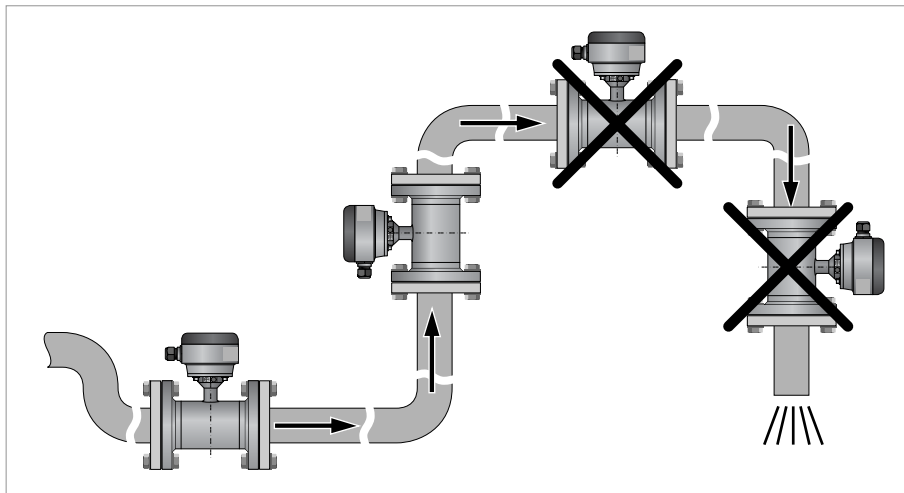

Figure 3-6: Installation in bending pipes (90°)

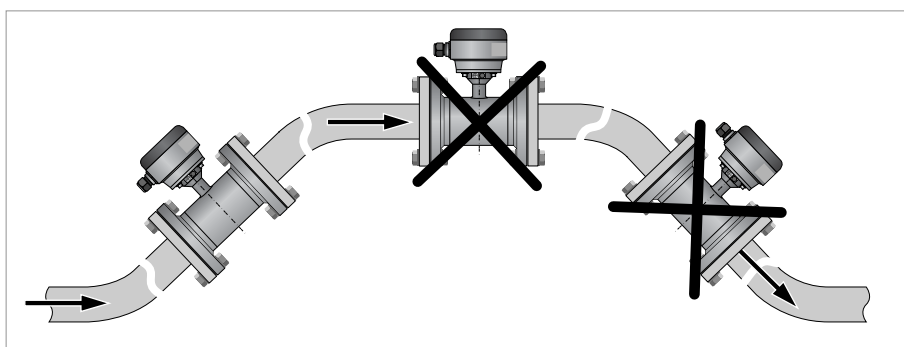

Figure 3-7: Installation in bending pipes (45°)

Avoid draining or partial filling of the flow sensor

3.3.5 Open discharge

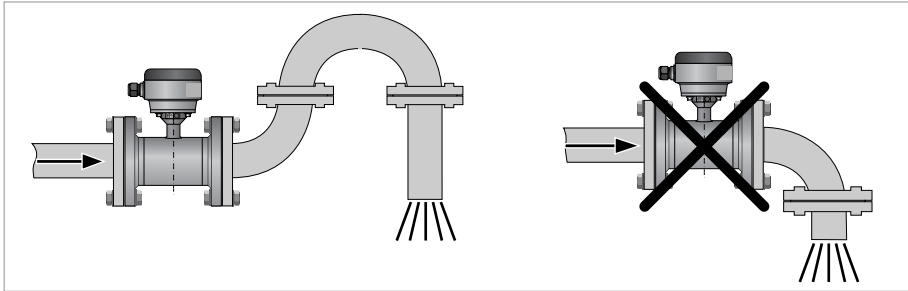

Figure 3-8: Installation in front of an open discharge

3.3.6 Pump

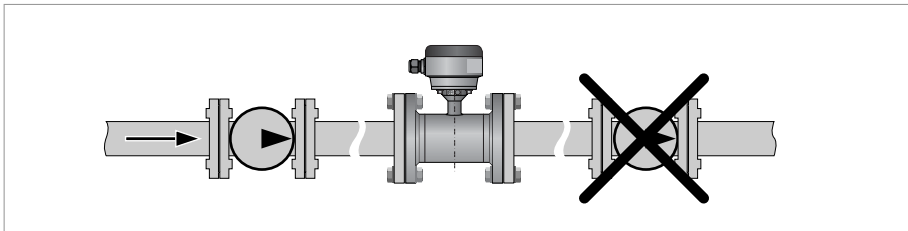

Figure 3-9: Installation behind a pump

3.3.7 Control valve

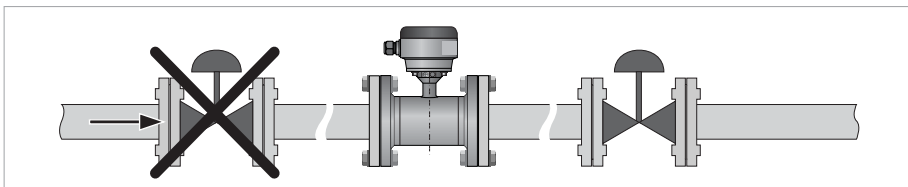

Figure 3-10: Installation in front of a control valve

3.3.8 Air venting and vacuum forces

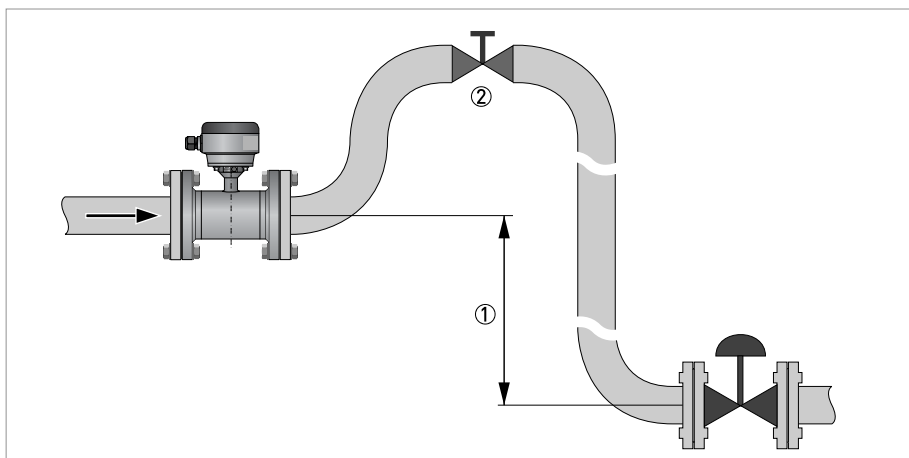

Figure 3-11: Air venting

- ① ≥ 5 m / 17 ft
- ② Air ventilation point

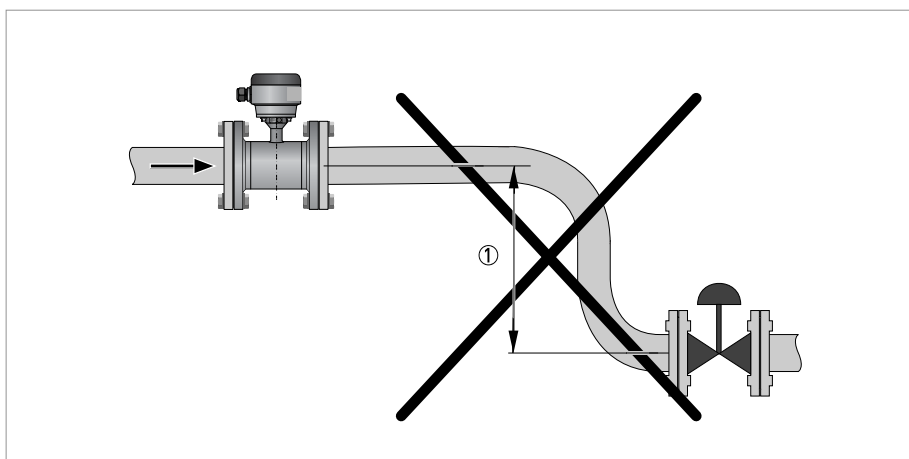

Figure 3-12: Vacuum

- ① ≥ 5 m / 17 ft

3.3.9 Flange deviation

Max. permissible deviation of pipe flange faces:
 $L_{max} - L_{min} \leq 0.5 \text{ mm} / 0.02''$

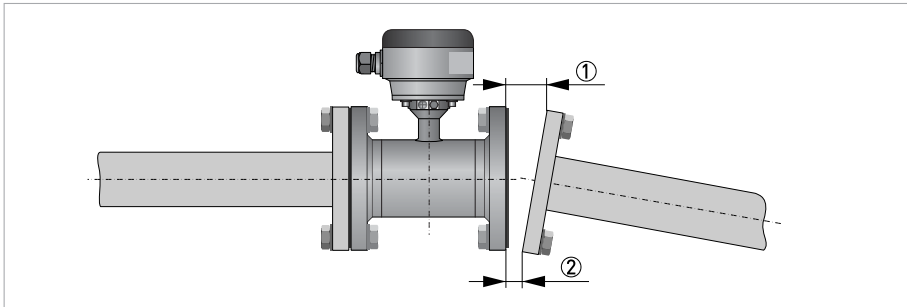

Figure 3-13: Flange deviation

- ① L_{max}
- ② L_{min}

3.3.10 Mounting position

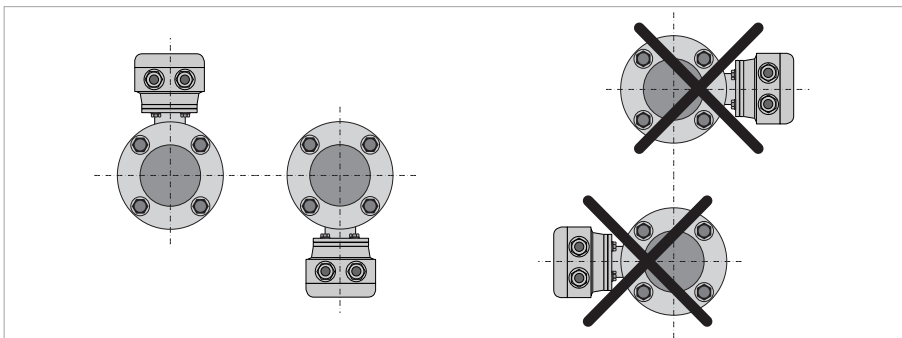

Figure 3-14: Mounting position

- Mount flow sensor either with signal converter aligned upwards or downwards.
- Install flow sensor in line with the pipe axis.
- Pipe flange faces must be parallel to each other.

3.4 Mounting

Please take care to use the proper gasket to prevent damaging the liner of the flowmeter. In general, the use of spiral wound gaskets is not advised, as it could severely damage the liner of the flowmeter.

3.4.1 Torques and pressures

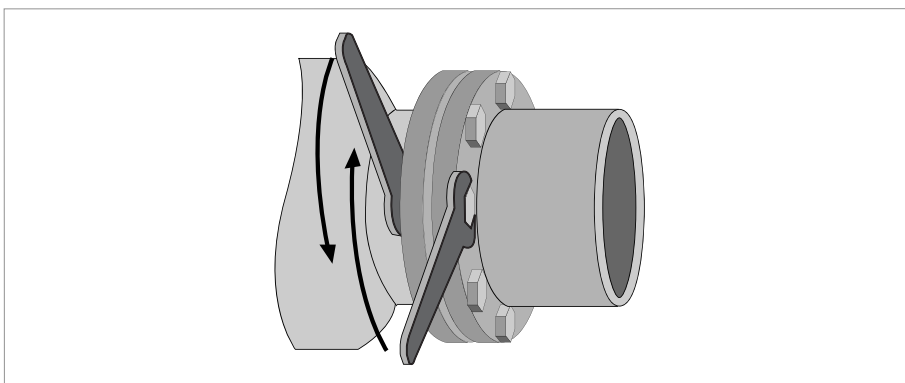

Figure 3-15: Tightening of bolts

Tightening of bolts

- Always tighten the bolts uniformly and in diagonally opposite sequence.
- Do not exceed the maximum torque value.
- Step 1: Apply approx. 50% of max. torque given in table.
- Step 2: Apply approx. 80% of max. torque given in table.
- Step 3: Apply 100% of max. torque given in table.

Other sizes / pressure ratings on request.

Nominal size DN [mm]	Pressure rating	Bolts ②	Max. torque [Nm] ①					
			PFA	PTFE	ETFE	PU	Hard rubber	Soft rubber
2.5	PN 40	4 x M 12	32	32	-	-	-	-
4	PN 40	4 x M 12	32	32	-	-	-	-
6	PN 40	4 x M 12	32	32	-	-	-	-
10	PN 40	4 x M 12	7.6	7.6	-	4.6	-	-
15	PN 40	4 x M 12	9.3	9.3	-	5.7	-	-
20	PN 40	4 x M 12	16	16	-	9.6	-	-
25	PN 40	4 x M 12	22	22	22	11	-	-
32	PN 40	4 x M 16	37	37	37	19	-	-
40	PN 40	4 x M 16	43	43	43	25	-	-
50	PN 40	4 x M 16	55	55	55	31	-	36
65	PN 16	4 x M 16	51	51	51	42	-	18
65	PN 40	8 x M 16	38	38	38	21	-	-
80	PN 40	8 x M 16	47	47	47	25	-	33
100	PN 16	8 x M 16	39	39	39	30	-	30
125	PN 16	8 x M 16	53	53	53	40	-	43
150	PN 16	8 x M 20	68	68	68	47	-	68
200	PN 10	8 x M 20	84	84	84	68	68	50
200	PN 16	12 x M 20	68	68	68	45	45	-
250	PN 10	12 x M 20	78	78	78	65	65	48
250	PN 16	12 x M 24	116	116	116	78	78	-
300	PN 10	12 x M 20	88	88	88	76	76	59
300	PN 16	12 x M 24	144	144	144	105	105	-
350	PN 10	16 x M 20	97	97	97	75	75	67
400	PN 10	16 x M 24	139	139	139	104	104	97
450	PN 10	20 x M 24	-	127	127	93	93	89
500	PN 10	20 x M 24	-	149	149	107	107	103
600	PN 10	20 x M 27	-	205	205	138	138	144
700	PN 10	20 x M 27	-	238	238	163	163	-
800	PN 10	24 x M 30	-	328	328	219	219	-
900	PN 10	28 x M 30	-	308	308	205	205	-
1000	PN 10	28 x M 35	-	392	392	261	261	-
③ *								

① The specified torque values are dependent on variables (temperature, bolt material, gasket material, lubricants, etc.) which are not within the control of the manufacturer. Therefore the values should be regarded as indicative only.

② F= ASTM gr B7 Studbolts - F=0.14 - Carbon steel flanges

③ * Information DN > 1000; please contact the support service department

Nominal size [inch]	Flange class [lb]	Bolts ②	Max. torque [in-lb] ①					
			PFA	PTFE	ETFE	PU	Hard rubber	Soft rubber
1/10	150	4 x 1/2"	39	39	-	-	-	-
1/6	150	4 x 1/2"	39	39	-	-	-	-
1/4	150	4 x 1/2"	39	39	-	-	-	-
3/8	150	4 x 1/2"	39	39	-	-	-	-
1/2	150	4 x 1/2"	34	34	-	-	-	-
3/4	150	4 x 1/2"	50	50	-	-	-	-
1	150	4 x 1/2"	67	67	67	-	-	-
1 1/4	150	4 x 1/2"	97	97	97	-	-	-
1 1/2	150	4 x 1/2"	138	138	138	-	-	-
2	150	4 x 5/8"	225	225	225	-	-	158
3	150	4 x 5/8"	380	380	380	-	-	283
4	150	8 x 5/8"	300	300	300	-	-	207
6	150	8 x 3/4"	540	540	540	-	-	328
8	150	8 x 3/4"	979	979	979	818	818	418
10	150	12 x 7/8"	1104	1104	1104	923	923	601
12	150	12 x 7/8"	1478	1478	1478	1237	1237	676
14	150	12 x 1"	1835	1835	1835	1538	1538	909
16	150	16 x 1"	1767	1767	1767	1481	1481	1141
18	150	16 x 1 1/8"	-	2605	2605	2183	2183	1100
20	150	20 x 1 1/8"	-	2365	2365	1984	1984	1618
24	150	20 x 1 1/4"	-	3419	3419	2873	2873	1479
28	150	28 x 1 1/4"	-	2904	2904	-	③ *	2155
32	150	28 x 1 1/2"	-	4560	4560	-	*	-
36	150	32 x 1 1/2"	-	-	③ *	-	*	-
40	150	36 x 1 1/2"	-	-	*	-	*	-

① The specified torque values are dependent on variables (temperature, bolt material, gasket material, lubricants, etc.) which are not within the control of the manufacturer. Therefore the values should be regarded as indicative only.

② F= ASTM gr B7 Studbolts - F=0.14 - Carbon steel flanges

③ Information * ; please contact the support service department

Other sizes / pressure ratings on request.

- Pressures are applicable at 20° C / 68° F.
- For higher temperatures, the pressure ratings are as per ASME B16.5.

4.1 Safety instructions

*All work on the electrical connections may only be carried out with the power disconnected.
Take note of the voltage data on the nameplate!*

Observe the national regulations for electrical installations!

*Observe without fail the local occupational health and safety regulations.
Any work done on the electrical components of the measuring device may only be carried out by
properly trained specialists.*

*Look at the device nameplate to ensure that the device is delivered according to your order.
Check for the correct supply voltage printed on the nameplate.*

4.2 Grounding

*The device must be grounded in accordance with regulations in order to protect personnel
against electric shocks.*

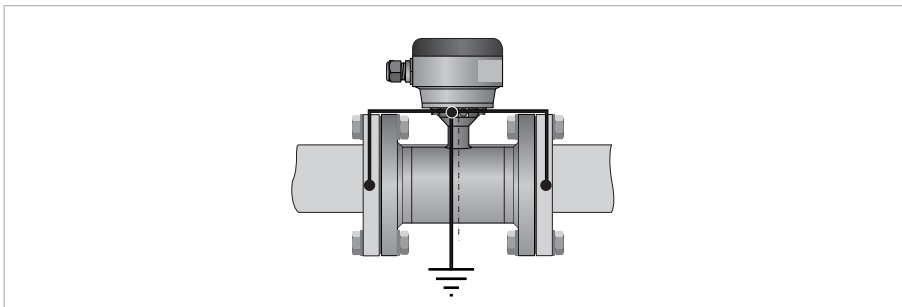

Figure 4-1: Grounding

Metal pipelines, not internally coated. Grounding without grounding rings.

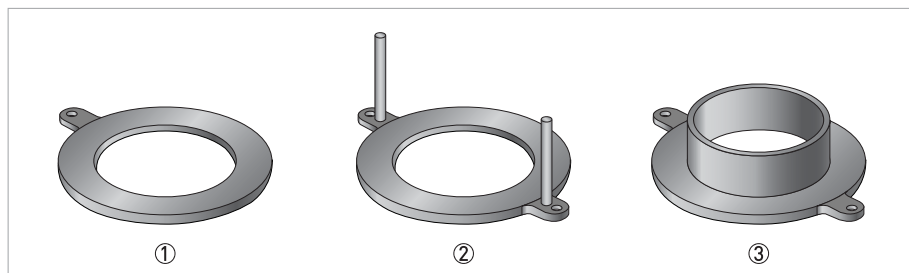

Figure 4-2: Different types of grounding rings

- ① Grounding ring number 1
- ② Grounding ring number 2
- ③ Grounding ring number 3

Grounding ring number 1:

- Thickness : 3 mm / 0.1" (tantalum: 0.5 mm / 0.02")

Grounding ring number 2:

- Thickness : 3 mm / 0.1"
- Prevents damage to the flanges during transport and installation
- Especially for flow sensors tube with PTFE liner

Grounding ring number 3:

- Thickness : 3 mm / 0.1"
- With cylindrical neck (length 30 mm / 1.25" for DN10...150 / 3/8...6")
- Offers liner protection against abrasive fluids

4.3 Virtual reference for IFC 300 (C, W and F version)

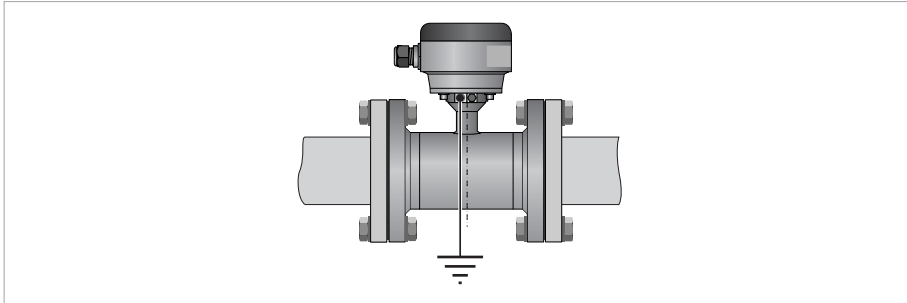

Figure 4-3: Virtual reference

Minimum requirements:

- Size: \geq DN10 / 3/8"
- Electrical conductivity: \geq 200 μ S/cm
- Signal cable: max. 50 m / 164 ft, type DS

4.4 Connection diagrams

For the connection diagrams and more information on connection of the sensor, please refer to the documentation of the applicable signal converter.

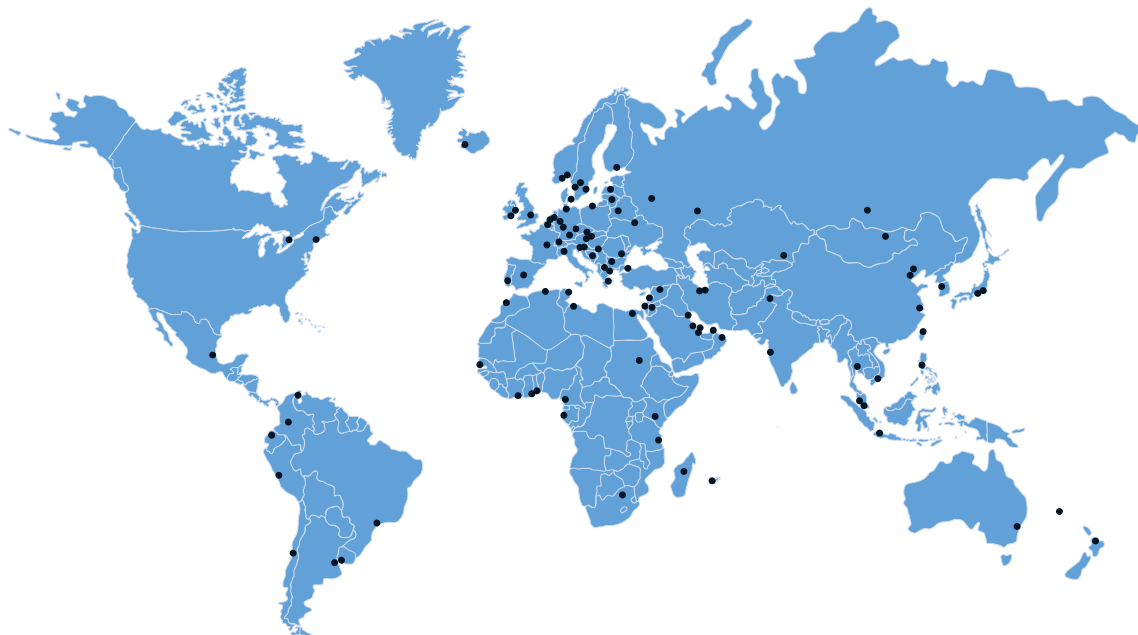

KROHNE – Process instrumentation and measurement solutions

- Flow
- Level
- Temperature
- Pressure
- Process Analysis
- Services

Head Office KROHNE Messtechnik GmbH
Ludwig-Krohne-Str. 5
47058 Duisburg (Germany)
Tel.: +49 203 301 0
Fax: +49 203 301 10389
info@krohne.com

The current list of all KROHNE contacts and addresses can be found at:
www.krohne.com

KROHNE