

Level Probes *multicap DC 11/16/21/26 EN* *multicap DC 11/16/21/26 ES*

**Fully and partially insulated rod and rope probes
for capacitive level measurement
and limit detection
(European certificates)**

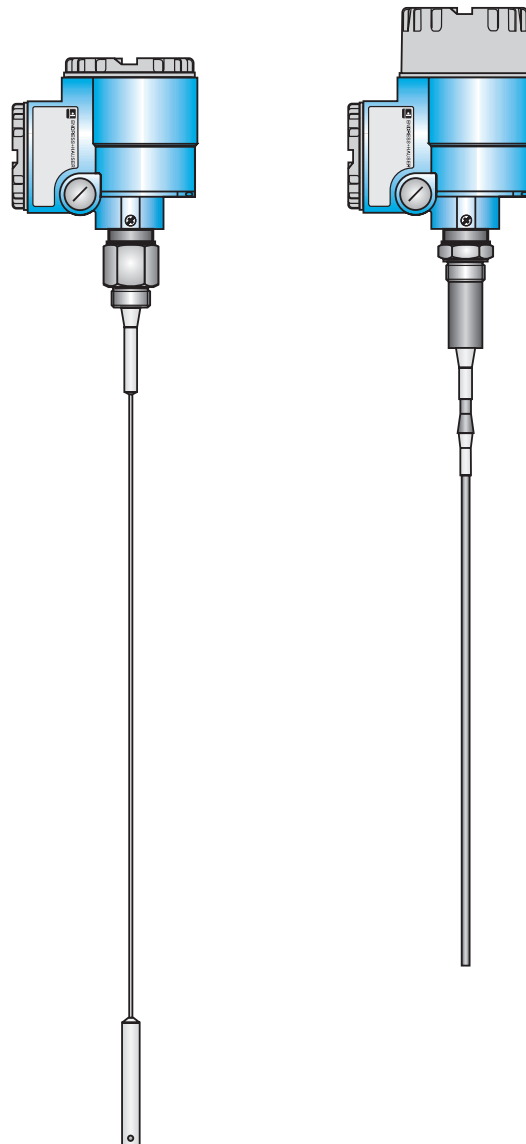

Application

Multicap probes are designed for continuous level measurement and limit detection, primarily in liquids. The DC 11 and DC 16 rod probes are also suitable for use in light bulk solids.

The probe rod or probe rope and insulation are made of corrosion-resistant materials able to withstand extremely aggressive products. The tried-and-tested rugged construction is gas-tight for pressure from vacuum to 100 bar. Seal and insulation materials enable probes to be used at operating temperatures in the vessel of -80°C to $+200^{\circ}\text{C}$.

Features and Benefits

Certificates from many European approval authorities
= the probes have universal use

Versions for a wide range of applications
= ideally adapted to your application at a cost effective price

Screened against condensation in the nozzle
= reliable function even with condensation

Active build-up compensation for limit detection
= steady and accurate switchpoint even with heavy contamination on the probe, no cleaning or recalibration

Endress + Hauser

The Power of Know How



Measuring System

Left: Limit detection with separate Nivotester switching unit

Right: Level measurement with separate Silometer transmitter

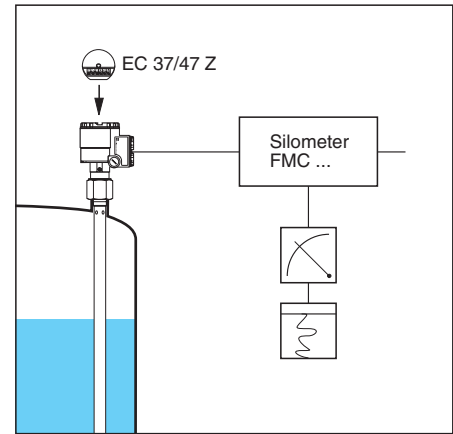
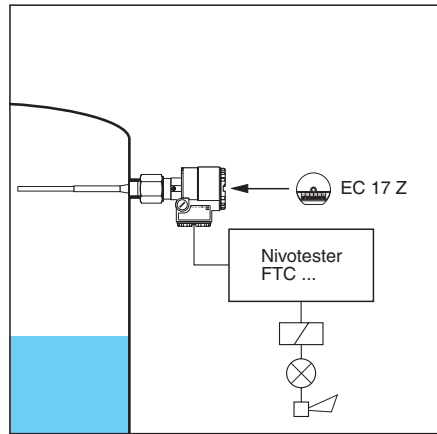

Left: Compact level switch with relay or transistor output

Right: Compact level measurement system with standard 4...20 mA current output and superimposed communications signal. FEC 12: "Smart electronic insert" which allows remote calibration over two-wire cabling (HART protocol) FEC 14: Communication and commissioning with PROFIBUS PA

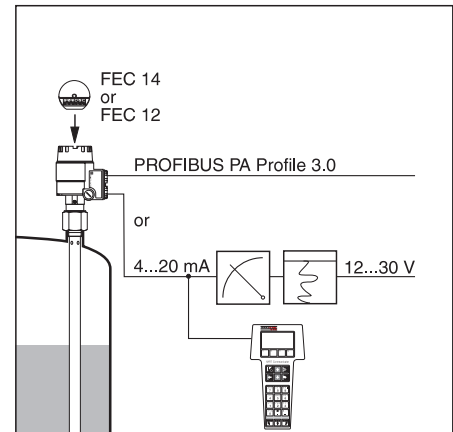
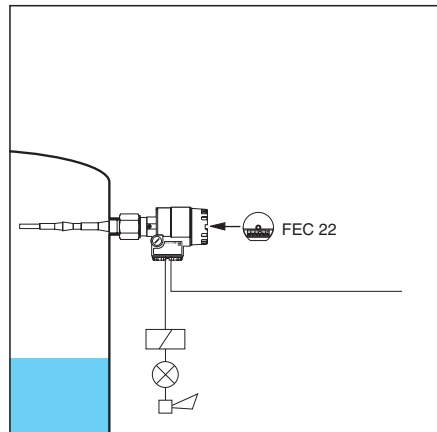

Probe Selection

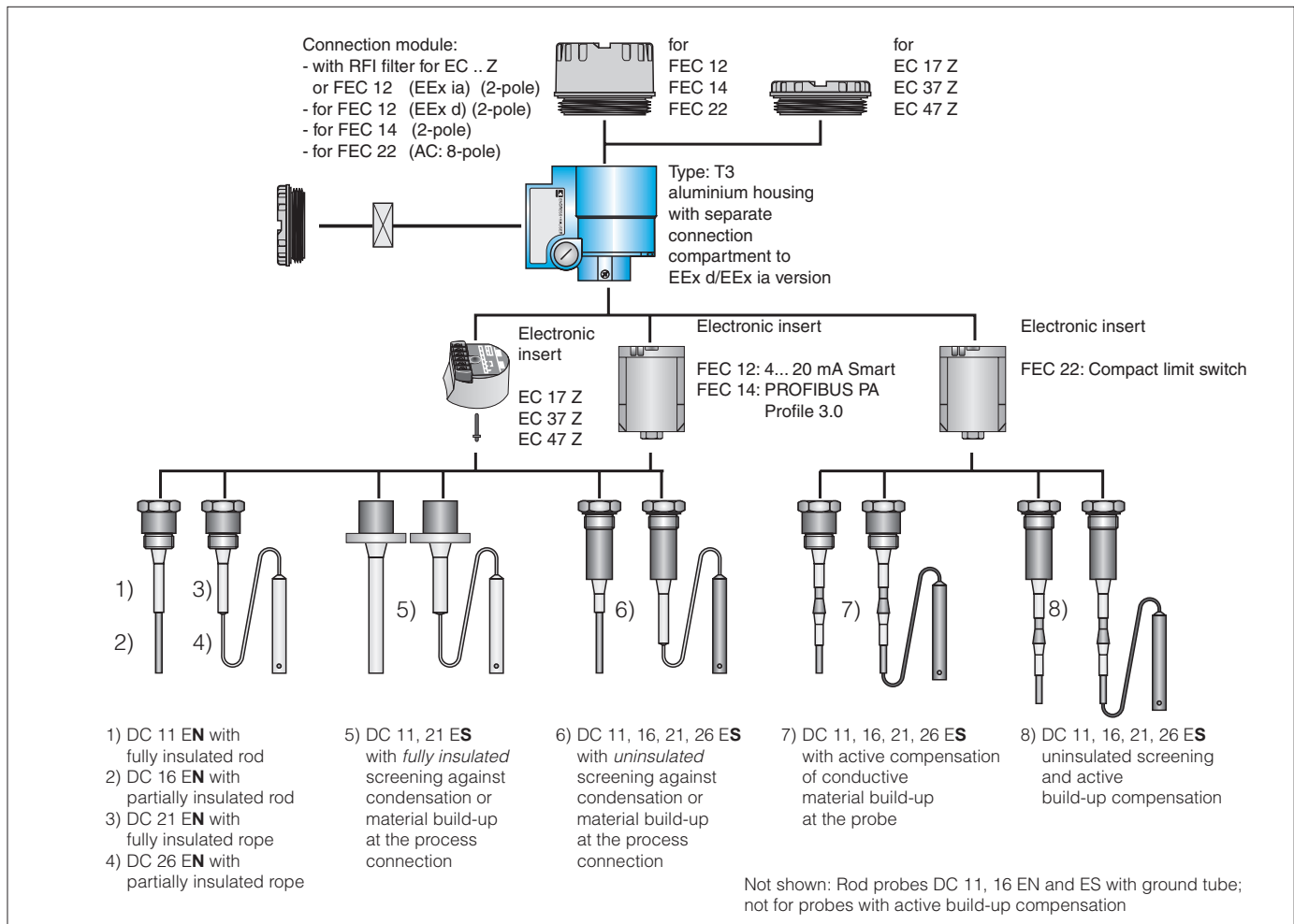

Dimensions

DC 11/16/21/26 EN

For all probes on this page:
 Those on the left have threads 1½ - 11½ NPT and those on the right threads G 1½ A;
 see Page 6 for other process connections and housing dimensions

L1 =Length of active probe rod or probe rope
 L2=Length of partial insulation
 minimum: 75 mm,
 maximum: length L1 minus 50 mm

Left: DC 11 EN,
 fully insulated rod probe

Right: DC 16 EN,
 partially insulated rod probe

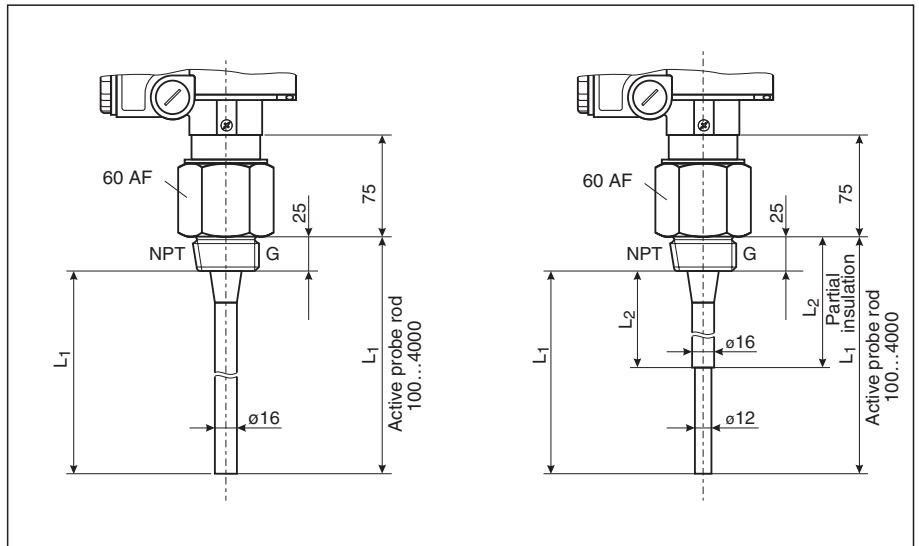

Left: DC 11 EN,
 fully insulated rod probe
 with ground tube

Right: DC 16 EN,
 partially insulated rod probe
 with ground tube

Spacers
 all 1000 mm, of PFA

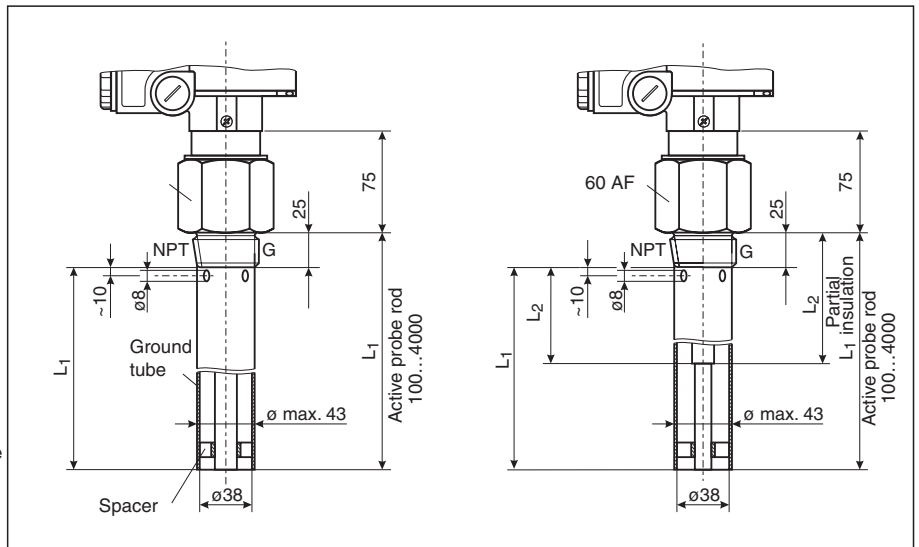

Left: DC 21 EN,
 fully insulated rope probe

Right: DC 26 EN,
 partially insulated rope probe

Tensioning weight always
 with anchor hole

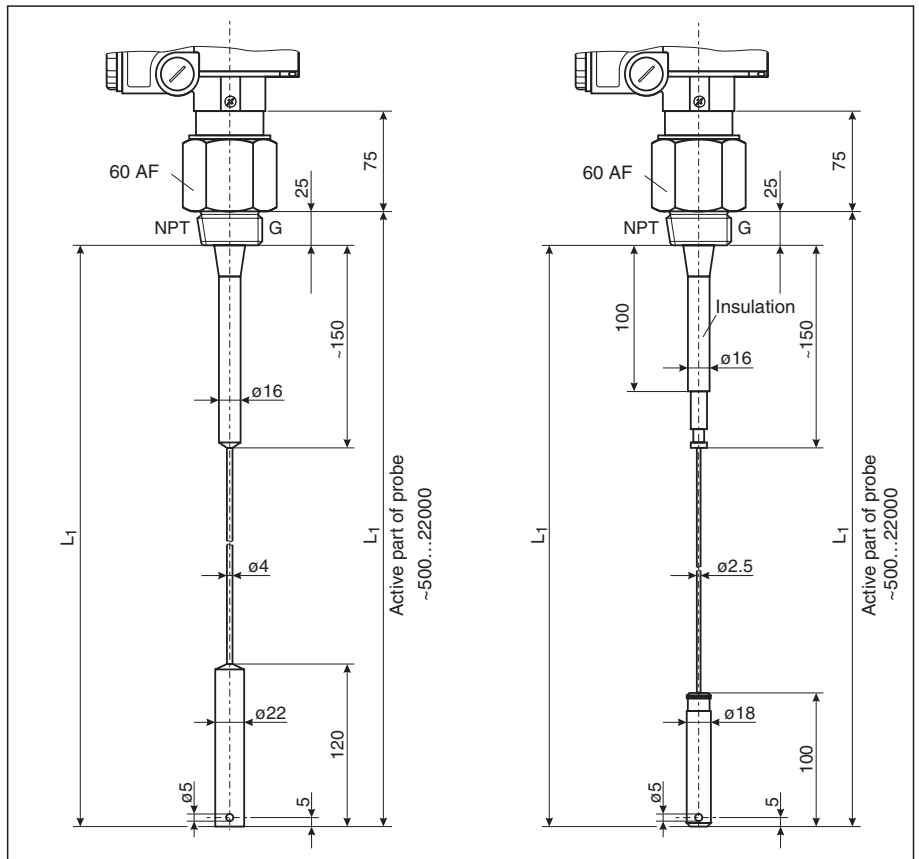

Dimensions

DC 11/16/21/26 ES

Probe with screening L3 against condensation and material build-up at the process connection (inactive section)

For probes with threaded boss on this page: Those on the left with thread 1½ - 11½ NPT and on the right with thread G 1½ A; see Page 6 for other process connections

L1 =Length of active probe rod or probe rope

L2 =Length of partial insulation min.: 75 mm, max.: length L1 minus 50 mm

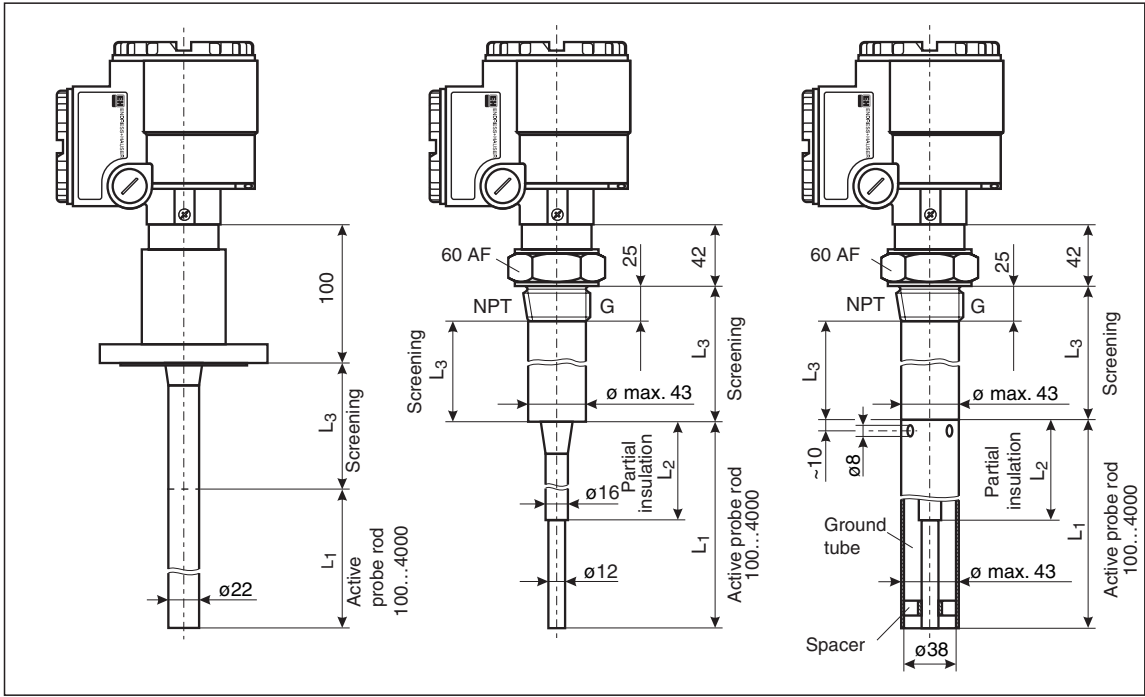

Above left: DC 11 ES, fully insulated rod probe with fully insulated screening and plastic coated flange

Above, centre and right: rod probes with uninsulated screening, with partially insulated rod with full insulation also available:

DC 11 ES, fully insulated
DC 16 ES, partially insulated

With ground tube
DC 11 ES, fully insulated
DC 16 ES, partially insulated

Left: DC 21 ES, fully insulated rope probe with fully insulated screening and plastic coated flange

Right: DC 26 ES, partially insulated rope probe with uninsulated screening, uninsulated rope and uninsulated tensioning weight (as shown)

With fully insulated active section this probe is designated DC 21 ES

L3
The screening (protection against condensation) is available in three standard lengths:
L3 = 150 mm
L3 = 250 mm
L3 = 500 mm

Other lengths on request
L3 min. 100 mm
L3 max. 4000 mm (uninsulated)
L3 max. 2000 mm (fully insulated)

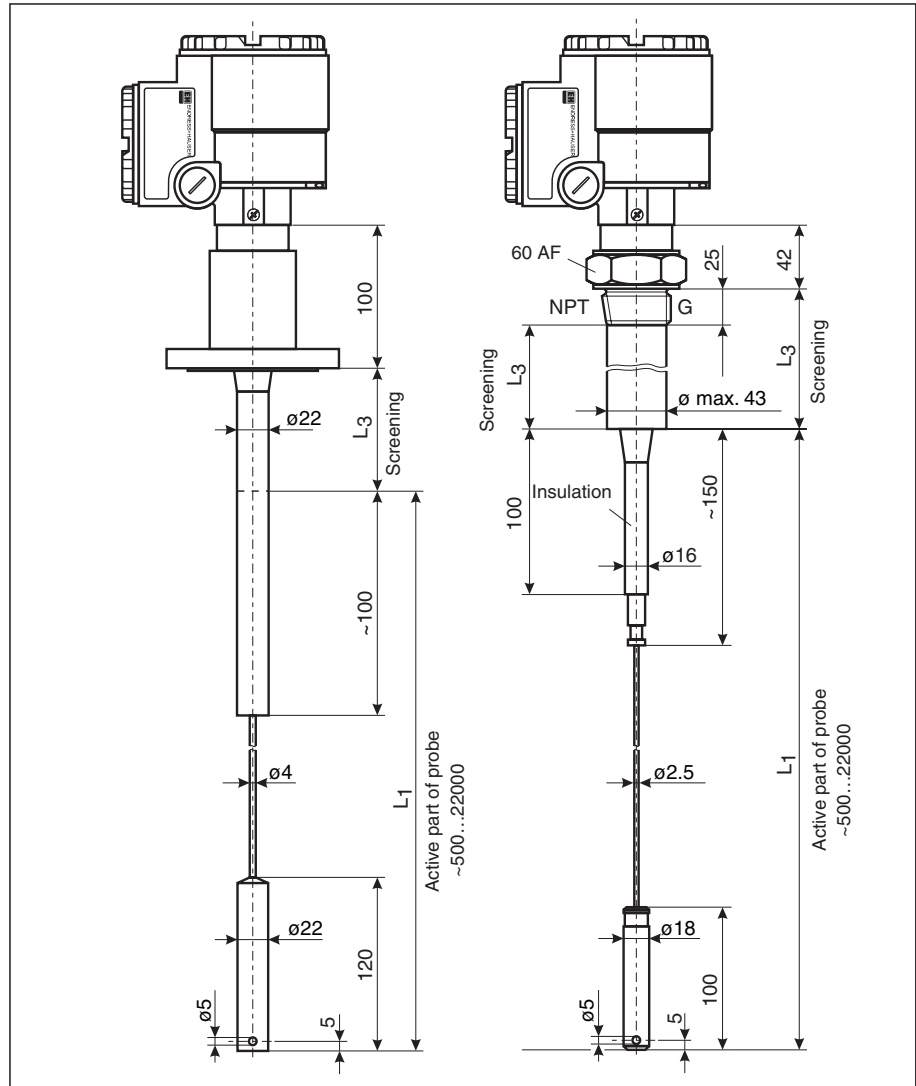

Dimensions

DC 11/16/21/26 ES Continued

Probes with active build-up compensation (active guard) (for limit detection, length always 150 mm)

Partially insulated probes shown but fully insulated probes also available where the active part of build-up compensation is always uninsulated. Not available with ground tube.

Threaded versions: G 1½ A
1½ - 11½ NPT

Left: rod probe
DC 11 ES
(fully insulated) or
DC 16 ES
(partially insulated)

Right: active build-up compensation combined with screening L3

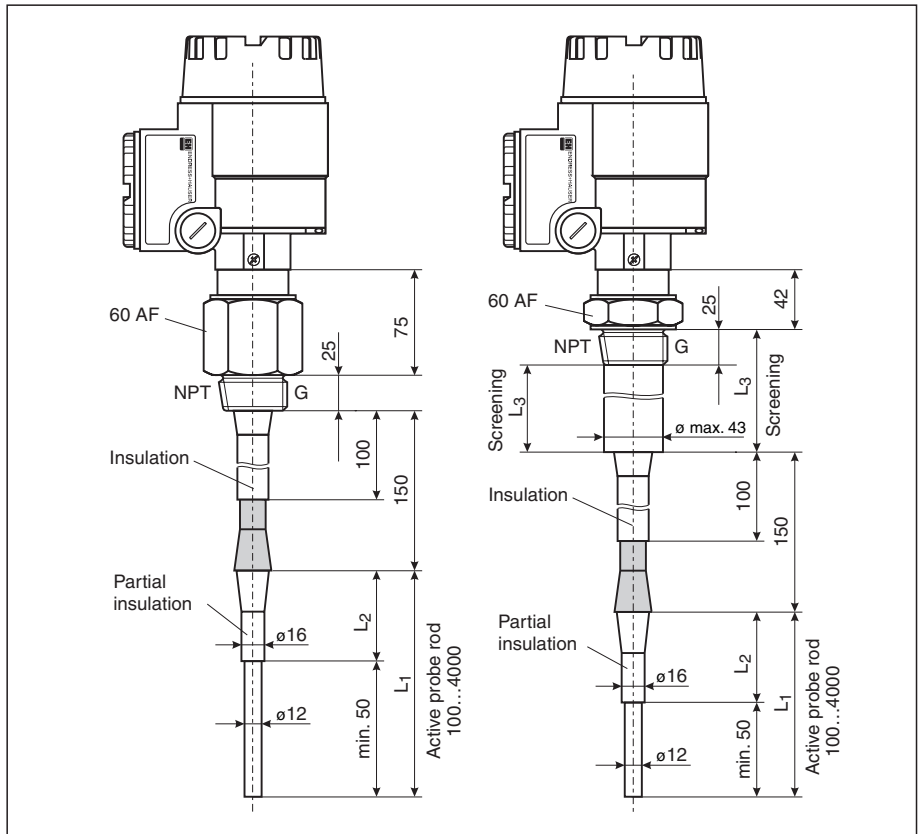

Left: rope probe
DC 21 ES
(fully insulated)
or DC 26 ES
(partially insulated)

Right: Active build-up compensation combined with screening L3

L3
The screening (protection against condensation) is available in three standard lengths:
L3 = 150 mm
L3 = 250 mm
L3 = 500 mm

Other lengths on request
L3 min. 100 mm
L3 max. 4000 mm

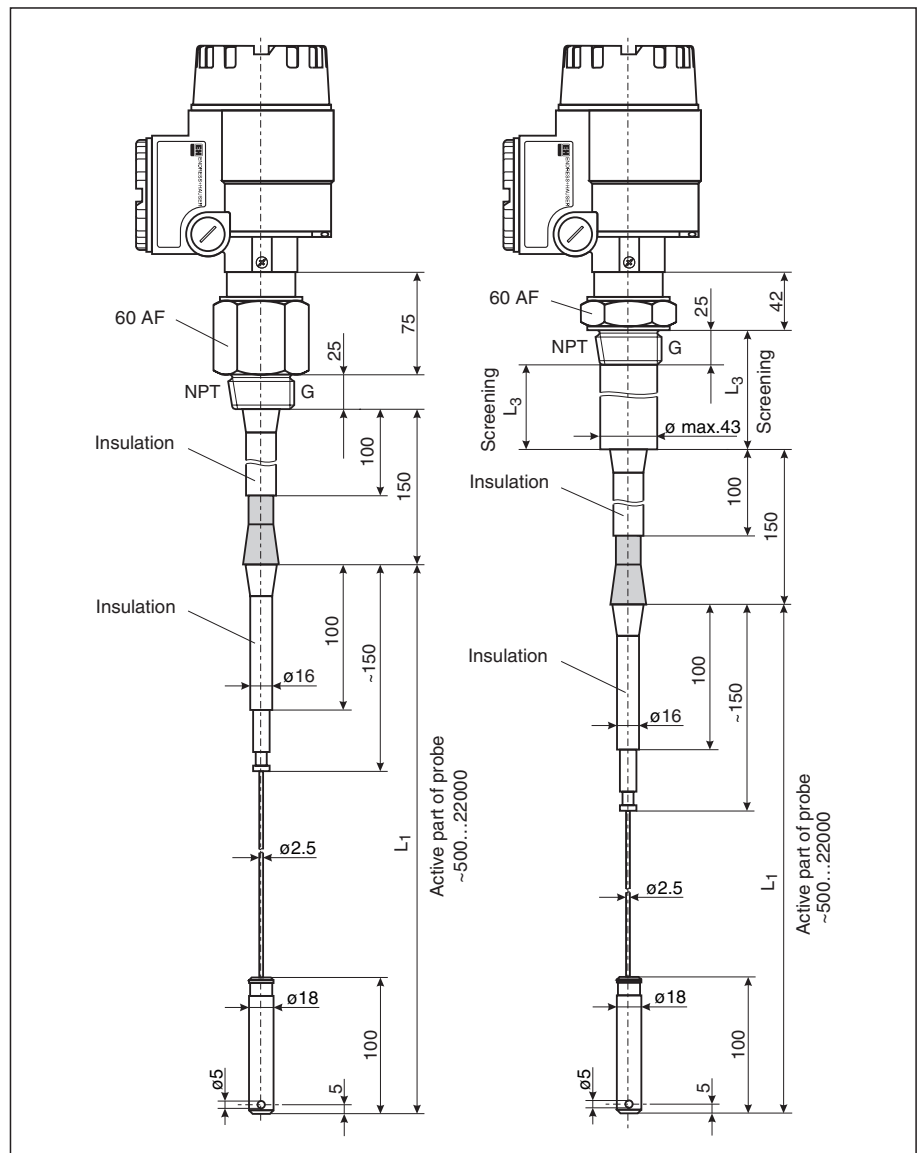

Additional Process Connections and Accessories

Other process connections:

- Flange
- Triclamp 2"
- Sanitary coupling DN 50

*h = 100 mm for probes

- DC...EN
- DC...ES with fully insulated screening (protection against condensation)
- DC...ES with active build-up compensation

*h = 47 mm for probes

- DC...ES with uninsulated screening (protection against condensation)
- DC...ES with uninsulated screening and active build-up compensation

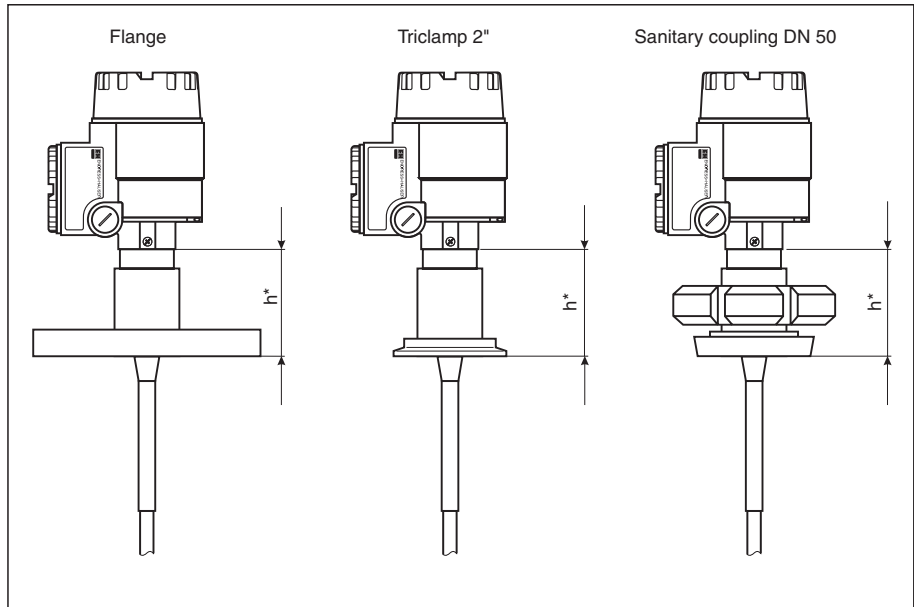

Additional equipment:

- A Temperature spacer for probes
- DC...EN
 - DC...ES with fully insulated screening (protection against condensation)
 - DC...ES with active build-up compensation

- B Temperature spacer for probes
- DC...ES with uninsulated screening (protection against condensation)
 - DC...ES with uninsulated screening and active build-up compensation

C Corrosion-resistant steel tag

- D Gas-tight gland for probes
- DC...EN
 - DC...ES with active build-up compensation

- E Gas-tight gland for probes
- DC...ES with uninsulated screening (protection against condensation)
 - DC...ES with uninsulated screening and active build-up compensation

- F Gas-tight gland for probes
- DC...ES with fully insulated screening (protection against condensation)

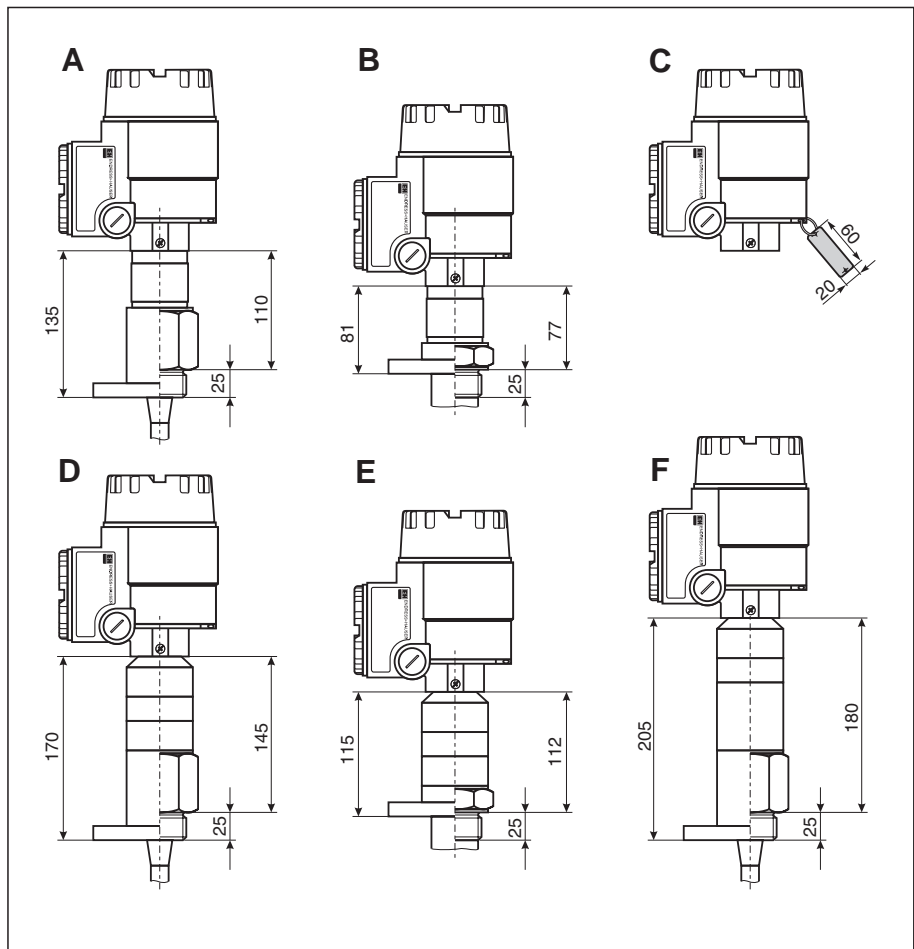

Housing Dimensions

Housings in aluminium (Type T3) with separate connection compartment;

- RFI filter with small electronic inserts EC 17 Z, EC 37 Z, EC 47 Z and FEC 12 (EEx ia),
- safety barriers with FEC 12 (EEx d),
- terminal connection module for FEC 22

With low cover for small electronic inserts EC...Z, with raised cover for electronic inserts FEC 12, FEC 14, FEC 22 with two cable entries, one sealed with a blind plug

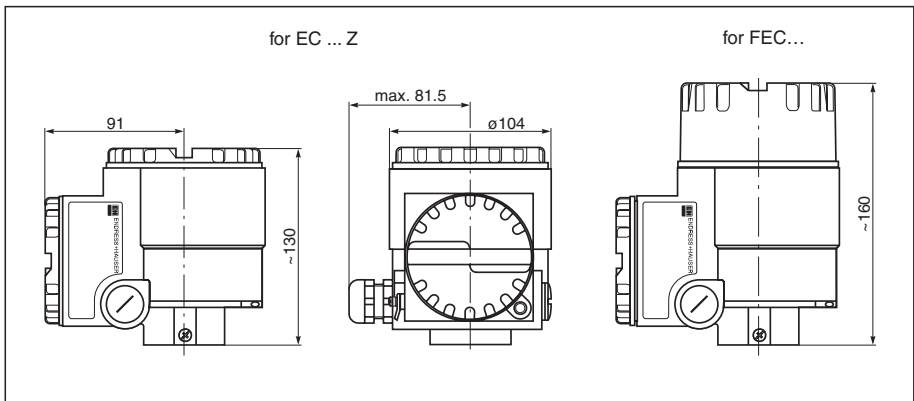

Technical Data

General Information

Manufacturer	Endress+Hauser GmbH+Co. D-79689 Maulburg
Instrument family	Multicap
Instrument types	DC 11, 16, 21, 26 EN / ES
Function	Probes for capacitive level measurement and limit detection

Operating Data

Operating pressure	to 100 bar, depending on material – see below
Operating temperature	to 200°C, depending on material – see below
Testing pressure	to 150 bar / temperature 20°C by repetitive test as requested

Permitted operating pressures p_e and temperatures T_B

The graph **A** do not apply to:

- DC 21 EN / DC 21 ES,
- DC 26 EN / DC 26 ES,
- probes with active build-up compensation,
- probes with fully insulated screening.

The graph **B** applies to:

- DC 21 EN / DC 21 ES,
- DC 26 EN / DC 26 ES,
- probes with active build-up compensation,
- probes with fully insulated screening.

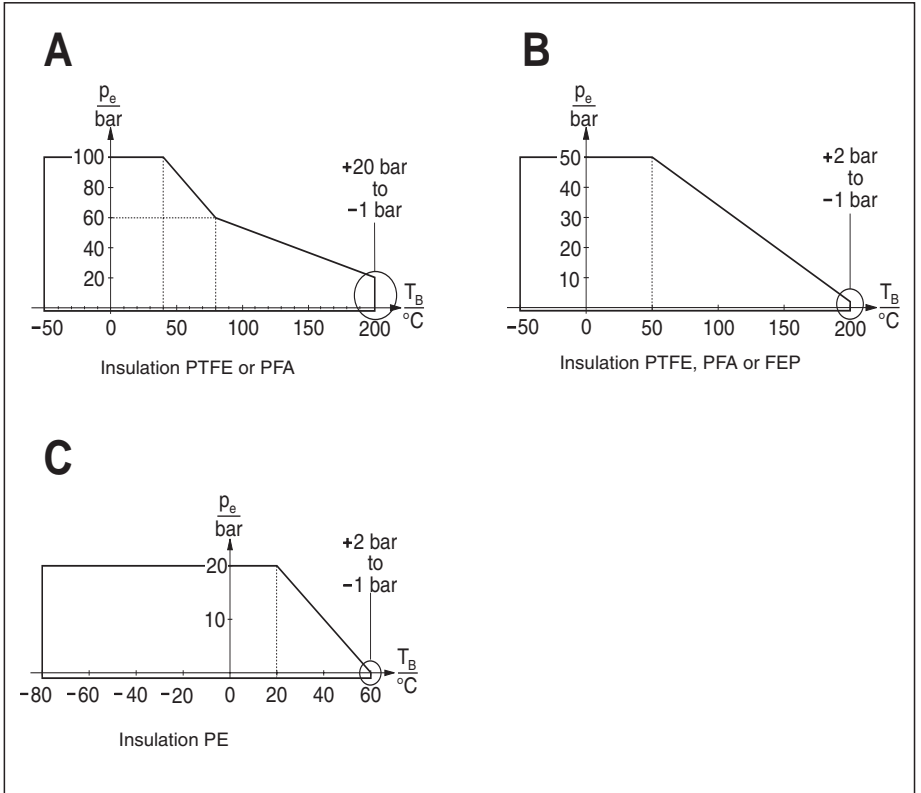

Mounting of the electronic insert as a function of operating temperature T_B and ambient temperature T_U :

- A Probe without temperature spacer
- B Probe with temperature spacer or gas-tight gland
- C Electronic insert in separate housing
- D Probe with temperature spacer or gas-tight gland and electronic insert in separate housing

The graphs A and B apply to **all** electronic inserts.

The graphs C and D apply to the small electronic inserts EC 17 Z, EC 37 Z, EC 47 Z

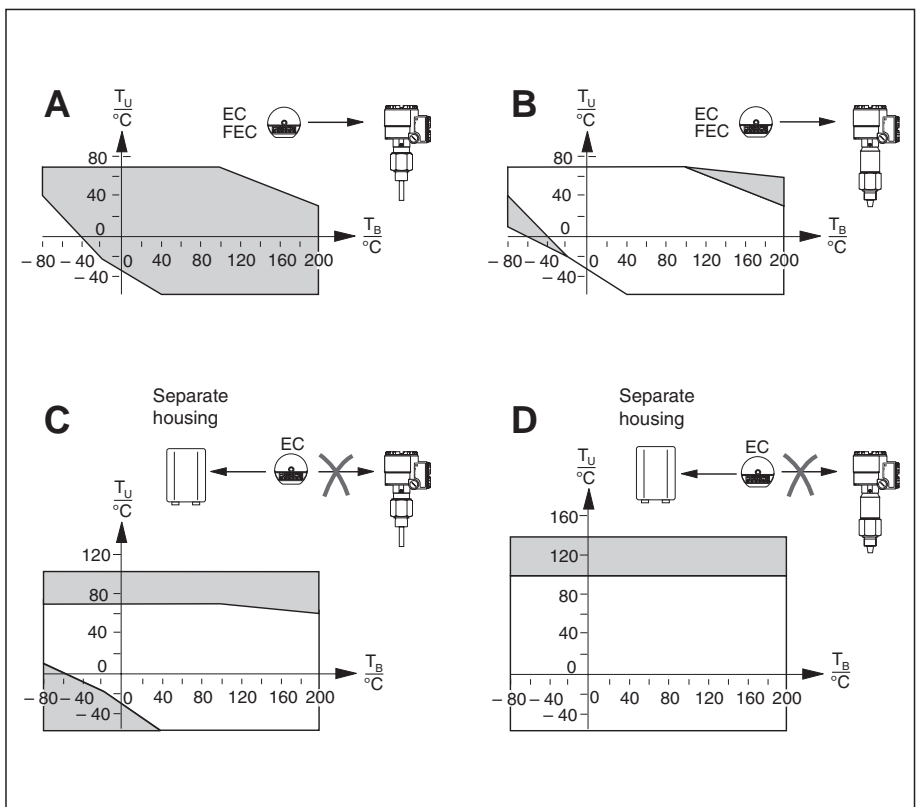

Other Operating Data

Lateral load on the probe rod	see below
Strain on the probe rope	200 N at 20°C, static

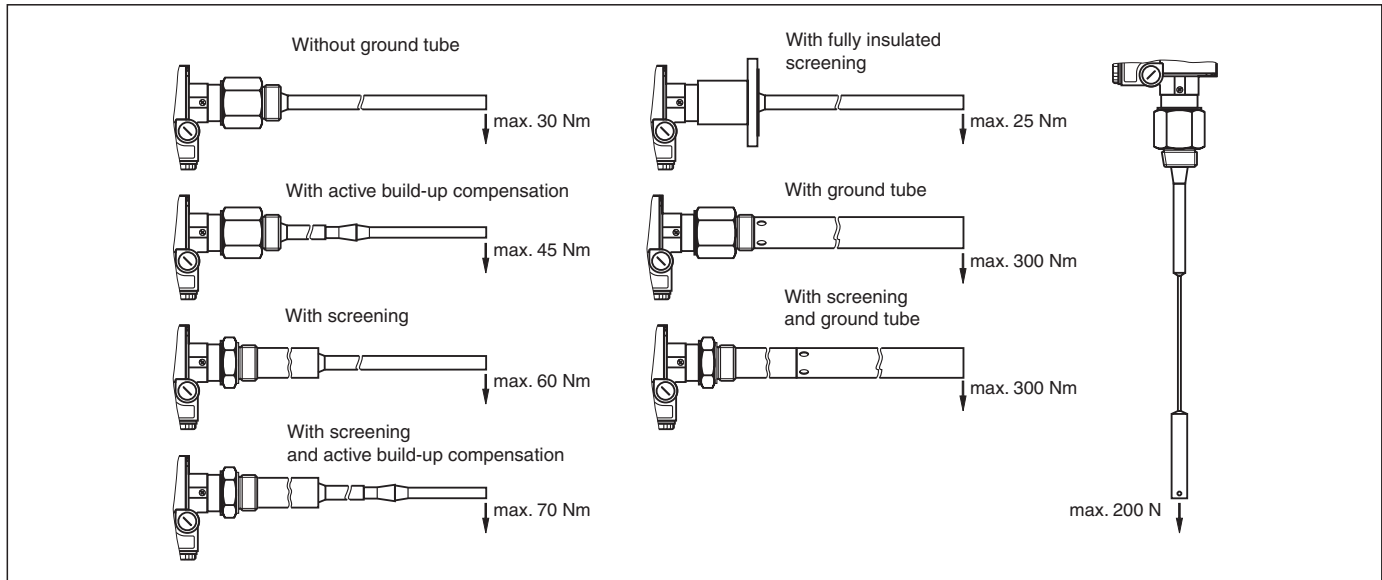

Permissible lateral load on the probes

Probe lengths

Total length of a rod probe	min. 100 mm, max. 6000 mm, see dimensions
Total length of a rope probe	min. 500 mm, max. 26000 mm, see dimensions

Capacitance values of the probe

Basic capacitance	approx. 30 pF
Temperature spacer	approx. 20 pF
Air-tight entry	approx. 20 pF
Active build-up compensation	approx. 10 pF

Additional capacitances

Probe 250 mm from a conductive vessel wall	insulated probe rod	in air approx. 1.3 pF/100 mm, in water approx. 38 pF/100 mm
	uninsulated probe rod	in air approx. 1.3 pF/100 mm
	insulated probe rope	in air approx. 1.0 pF/100 mm, in water approx. 20 pF/100 mm
	uninsulated probe rope	in air approx. 1.0 pF/100 mm
	insulated tensioning weight	in air approx. 2 pF in water approx. 60 pF
uninsulated tensioning weight	in air approx. 2 pF	
Rod probe with ground tube	insulated probe rod	in air approx. 5.5 pF/100 mm, in water approx. 35 pF/100 mm
	uninsulated probe rod	in air approx. 5.0 pF/100 mm
Uninsulated screening	approx. 3 pF/100 mm	
Fully insulated screening	approx. 6 pF/100 mm	

Probe lengths for continuous measurement in conducting liquids

EC with $C_{max.} = 2000$ pF (EC 47 Z, FEC 12)	Rope probe up to 8000 mm (up to 26000 mm in non-conducting liquids) rod probe up to 6000 mm
EC with $C_{max.} = 4000$ pF (EC 37 Z)	Rope probe up to 20000 mm (up to 26000 mm in non-conducting liquids) rod probe up to 6000 mm

Other Operating Data

Accuracy

Length tolerances	up to 1 m: + 0 mm, -5 mm rod probe, -10 mm rope probe
	up to 3 m: + 0 mm, -10 mm rod probe, -20 mm rope probe
	up to 6 m: + 0 mm, -20 mm rod probe, -30 mm rope probe
	up to 26 m: + 0 mm, -40 mm rope probe

The following specifications only apply to the capacitance of fully insulated probes when used in conductive liquids.

The deviation is insignificant for applications in non-conductive materials.

Linearity error in water	< 1 % at 1m length
Temperature dependence of the probe rod	< 0,1 % per K
Pressure dependence of the probe rod	approx. 0,2 % per bar
Temperature dependence of the probe rope	< 0.1 % per K
Pressure dependence of the probe rope	< 0.1 % per bar

Process connections

Parallel thread G 1½ A	DIN ISO 228/1, with sealing ring 48x55
Tapered thread 1½ - 11½ NPT	ANSI B 1.20.1
DIN flanges without raised face	DIN 2527, Form B
DIN flanges with tongue	DIN 2512, Form F
DIN flanges with groove	DIN 2512, Form N
ANSI flanges	ANSI B 16.5
Sanitary coupling	DIN 11 851
Triclamp coupling	ISO 2852

Materials

Aluminium housing (Type T3)	GD-Al Si 10 Mg, DIN 1725, plastic coated (blue / grey)
Seal for housing cover	O-ring in EPDM (elastomer)
Sealing ring for process connection G 1½ A	Elastomer-fibre, asbestos-free, resistant to oils, solvents, steam, weak acids and alkalis; up to 300 °C, and 100 bar
Temperature spacer	Stainless steel 1.4301 or similar
Gas-tight gland	Stainless steel 1.4301
Further material specifications	see Product Structure on Page 10...11

Product Structure

DC 11 EN-	MULTICAP DC 11 EN Fully insulated rod probe for standard applications	Basic weight including G 1½ A process connection and housing, for rope probes with tensioning weight	3,0 kg
DC 16 EN-	MULTICAP DC 16 EN Partially insulated rod probe for standard applications		3,0 kg
DC 21 EN-	MULTICAP DC 21 EN Fully insulated rope probe for standard applications		3,3 kg
DC 26 EN-	MULTICAP DC 26 EN Partially insulated rope probe for standard applications		3,2 kg
DC 11 ES-	MULTICAP DC 11 ES Fully insulated rod probe with protection features		3,0 kg
DC 16 ES-	MULTICAP DC 16 ES Partially insulated rod probe with protection features		3,0 kg
DC 21 ES-	MULTICAP DC 21 ES Fully insulated rope probe with protection features		3,3 kg
DC 26 ES-	MULTICAP DC 26 ES Partially insulated rope probe with protection features		3,2 kg

Certificate

- A For non-hazardous areas
- B ATEX II 1/2 G, EEx ia IIC T6
- D For non-hazardous areas, Overspill protection to WHG
- E ATEX II 2 G, EEx d [ia] IIC T6
- F ATEX II 1/2 G, EEx ia IIC T6, Overspill protection to WHG
- H ATEX II 3 G, EEx nA II T6
- Y Special version
- 1 ATEX II 2 G, EEx d [ia] IIB T6
- 2 ATEX II 1/2 G, EEx ia IIB T6, Overspill protection to WHG
- 3 ATEX II 1/2 G, EEx ia IIB T6
- 4 ATEX II 2 G, EEx d [ia] IIC T6*
- 5 ATEX II 1/2 G, EEx ia IIC T6*, Overspill protection to WHG
- 6 ATEX II 1/2 G, EEx ia IIC T6*
- 7 ATEX II 3 G, EEx nA II T6*

* Note: "Avoid electrostatic charge!"

Build-up protection

DC 11, 16, 21, 26 EN

A Build-up protection not selected

DC 11, 16, 21, 26 ES

B	150 mm active guard,	316Ti	0,5 kg
C	150 mm L3 screening,	316Ti	0,3 kg
D	250 mm L3 screening,	316Ti	0,5 kg
E	500 mm L3 screening,	316Ti	1,0 kg
Fmm (75 mm...4000 mm), L3 screening,	316Ti	2 kg/m
G	150 mm L3 screening and 150 mm active guard,	316Ti	0,8 kg
H	250 mm L3 screening and 150 mm active guard,	316Ti	1,0 kg
K	500 mm L3 screening and 150 mm, active guard,	316Ti	1,5 kg
Lmm (75 mm...4000 mm), L3 screening and 150 mm active guard,	316Ti	2 kg/m + 0,5 kg
1	150 mm active guard,	Alloy C	0,5 kg
3mm (75 mm...4000 mm), L3 screening,	Alloy C	2 kg/m
5mm (75 mm...4000 mm), L3 screening and 150 mm active guard,	Alloy C	2 kg/m + 0,5 kg
7mm (75 mm...4000 mm), L3 screening,	fully insulated	1 kg/m

Y Special version

Probe insulation

DC 11, 21 EN/ES

1 Fully insulated probe

DC 16 EN/ES

Amm (20 mm...4000 mm), L2,	PTFE insulated	0,1 kg/m
Bmm (20 mm...4000 mm), L2,	PFA insulated	0,1 kg/m
Cmm (20 mm...4000 mm), L2,	PE insulated	0,1 kg/m

DC 26 EN/ES

D Rope type: 2.5mm diameter

Y Special version

Active length L1, Material

DC 11 EN/ES

Amm (50 mm...22000 mm),	316Ti+PTFE	1 kg/m
Bmm (50 mm...22000 mm),	steel+PE	1 kg/m
Cmm (50 mm...22000 mm),	steel+PTFE	1 kg/m
Dmm (50 mm...22000 mm),	316Ti+PFA	1 kg/m
Emm (100 mm...22000 mm),	Alloy C+PTFE	1 kg/m
Fmm (100 mm...22000 mm),	Alloy C+PFA	1 kg/m
Gmm (100 mm...22000 mm),	316Ti+PTFE with ground tube	3 kg/m
Hmm (100 mm...22000 mm),	316Ti+PFA with ground tube	3 kg/m
Kmm (100 mm...22000 mm),	steel+PE with ground tube	3 kg/m
Lmm (100 mm...22000 mm),	Alloy C+PTFE with ground tube	3 kg/m
Mmm (100 mm...22000 mm),	Alloy C+PFA with ground tube	3 kg/m

Continued Page 11

DC . . E . -

Product designation (first part)

Product Structure (Continued)

Please don't forget:

Length of
Screening L3 mm

Partial insulation L2 mm

Active probe length L1 mm

		Active length L1, Material (Continued)	additional weights
DC 16 EN/ES			
Nmm (100 mm...22000 mm),	Rod, 316Ti	0,9 kg/m
Pmm (100 mm...22000 mm),	Rod, steel	0,9 kg/m
Rmm (100 mm...22000 mm),	Rod, Alloy C	0,9 kg/m
Smm (100 mm...22000 mm),	316Ti with ground tube	2,9 kg/m
Tmm (100 mm...22000 mm),	steel with ground tube	2,9 kg/m
Umm (100 mm...22000 mm),	Alloy C with ground tube	2,9 kg/m
DC 21 EN/ES			
1mm (100 mm...22000 mm), tensioning weight with anchor hole	Rope, 316, PE insulated	0,04 kg/m
2mm (100 mm...22000 mm), tensioning weight with anchor hole	Rope, 316, FEP insulated	0,04 kg/m
3mm (100 mm...22000 mm), tensioning weight with anchor hole	Rope, 316, PFA insulated	0,04 kg/m
DC 26 EN/ES			
4mm (100 mm...22000 mm), tensioning weight with anchor hole	Rope, 316	0,03 kg/m
5mm (100 mm...22000 mm), tensioning weight with anchor hole	Rope, Alloy C	0,03 kg/m
9	Special version		
Process connection, Material			
E	DN 50 PN 40, DIN 11851, Hygienic connection	304	0,5 kg
F	DN 40-51 (2"), ISO 2852, Tri-Clamp connection	304	0,5 kg
G	G 1½ A, Thread ISO 228,	steel	
H	G 1½ A, Thread ISO 228,	316Ti	
K	G 1½ A, Thread ISO 228,	Alloy C	
M	1½" NPT, Thread ANSI,	steel	
N	1½" NPT, Thread ANSI,	316Ti	
P	1½" NPT, Thread ANSI,	Alloy C	
Y	Special version		
5	Flanged process connection		
Flange type, Material			
AE2	2" 150 lbs, RF, ANSI B16.5,	316Ti	1,6 kg
AE3	2" 150 lbs, RF, ANSI B16.5,	PTFE >316Ti	1,6 kg
AG2	2" 300 lbs, RF, ANSI B16.5,	316Ti	3,0 kg
AL2	3" 150 lbs, RF, ANSI B16.5,	316Ti	3,2 kg
AL3	3" 150 lbs, RF, ANSI B16.5,	PTFE >316Ti	3,2 kg
AN2	3" 300 lbs, RF, ANSI B16.5,	316Ti	5,6 kg
AP2	4" 150 lbs, RF, ANSI B16.5,	316Ti	5,4 kg
AP3	4" 150 lbs, RF, ANSI B16.5,	PTFE >316Ti	5,4 kg
AR2	4" 300 lbs, RF, ANSI B16.5,	316Ti	7,3 kg
AV2	6" 150 lbs, RF, ANSI B16.5,	316Ti	
A12	6" 150 lbs, RF, ANSI B16.5,	316Ti	
BG1	DN 50 PN 25/40 B, DIN 2527,	steel	3,0 kg
BG2	DN 50 PN 25/40 B, DIN 2527,	316Ti	3,0 kg
BG3	DN 50 PN 25/40, DIN 2527,	PTFE >316Ti	3,0 kg
BM3	DN 80 PN 10/16, DIN 2527,	PTFE >316Ti	4,5 kg
BQ3	DN 100 PN 10/16, DIN 2527,	PTFE >316Ti	5,4 kg
CG2	DN 50 PN 25/40 C, DIN 2527,	316Ti	3,0 kg
CM2	DN 80 PN 10/16 C, DIN 2527,	316Ti	4,5 kg
CQ2	DN 100 PN 10/16 C, DIN 2527,	316Ti	5,4 kg
Nur DC 11, 16 EN/ES, DC 21 EN			
KE2	10K 50A, RF, JIS B2210,	316Ti	
KE3	10K 50A, RF, JIS B2210,	PTFE >316Ti	
KF1	20K 50A, RF, JIS B2210,	steel	2,6 kg
KF2	20K 50A, RF, JIS B2210,	316 Ti	2,6 kg
Nur DC 11, 16 EN/ES, DC 21 EN			
KL2	10K 80A, RF, JIS B2210,	316Ti	
KL3	10K 80A, JIS B2210,	PTFE >316Ti	
KP2	10K 100A, RF, JIS B2210,	316Ti	
KP3	10K 100A, JIS B2210,	PTFE >316Ti	
YYY	Special version		
1BB	without process flange connection		
Electronic insert			
E	with EC 17 Z, 2-wire PFM		0,2 kg
G	with EC 37 Z, 2-wire PFM, 33 kHz		0,2 kg
H	with EC 47 Z, 2-wire PFM, 1 MHz		0,2 kg
K	with FEC 12, 2-wire 4...20 mA HART		0,3 kg* +0,3 kg
M	with FEC 22, 90...253 V AC, DPDT relay		0,3 kg* +0,3 kg
N	with FEC 22, 10... 55 V DC, 3-wire PNP		0,3 kg* +0,3 kg
P	with FEC 14, PROFIBUS PA		
V	with FEC 14, local operation FHB 20 and PROFIBUS PA		
Y	Special version		
Housing			
G	Aluminium, T3 Housing, HNA24x1,5,		IP66
M	Aluminium, T3 Housing, gland M20x1,5,		IP66
P	Aluminium, T3 Housing, PA-plug M12,		IP66
S	Aluminium, T3 Housing, Nema 4x, NPT ¾"		
T	Aluminium, T3 Housing, entry G ½ A,		IP66
Y	Special version		
Option			
1	Basic version		
3	with temperature spacer		0,5 kg
5	with gas-tight probe seal		0,5 kg
9	Special version		
* Additional weight for raised cover			
		DC . . E . -	Complete product designation for DC . . EN, DC . . ES

Accessories

- Slip-on sheet for partially insulated probes for increasing the switching safety for limit detection see Technical Information "Probe accessories"
- Rope shortening kit for fully insulated probes
- Rope shortening kit for partially insulated probes

Supplementary Documentation

Technical Information

- Probe accessories
Technical Information TI 229F/00/en
- Electronic insert FEC 12
Technical Information TI 250F/00/en
- Electronic insert FEC 14
Technical Information TI 376F/00/en
- Electronic insert FEC 22
Technical Information TI 251F/00/en
- Electronic insert EC 17 Z
Technical Information TI 268F/00/en
- Electronic insert EC 37 Z, EC 47 Z
Technical Information TI 271F/00/en
- Transmitters for limit detection and continuous level measurement on request

Certificates

- See product structure on page 10

Endress+Hauser
GmbH+Co. KG
Instruments
International
P.O. Box 2222
D-79574 Weil am Rhein
Germany

Tel. (07621) 975-02
Fax (07621) 975-345
<http://www.endress.com>
info@ii.endress.com

Endress + Hauser
The Power of Know How

