

Technical Information

Micropilot FMR51, FMR52

Free space radar

Level measurement in liquids



Application

- Continuous, non-contact level measurement of liquids, pastes and slurries
- Horn antenna (FMR51); flush mounted, completely filled PTFE horn antenna (FMR52)
- Maximum measuring range: 70 m (230 ft)
- Temperature: -196 to $+450$ °C (-321 to $+842$ °F)
- Pressure: -1 to $+160$ bar (-14.5 to $+2\,320$ psi)
- Accuracy: ± 2 mm
- International explosion protection certificates; WHG; marine approvals
- Linearity protocol (3-point, 5-point)

Your benefits

- Reliable measurement even for changing product and process conditions
- HistoROM data management for easy commissioning, maintenance and diagnostics
- Highest reliability due to Multi-Echo Tracking
- SIL2 according to IEC 61508, SIL3 in case of homogeneous or heterogeneous redundancy
- Seamless integration into control or asset management systems
- Intuitive user interface in national languages
- Easy proof test for SIL and WHG

Table of contents





Important document information	4	Degree of protection	58
Symbols	4	Vibration resistance	58
Function and system design	6	Cleaning the antenna	58
Measuring principle	6	Electromagnetic compatibility (EMC)	59
Input	8	Process	60
Measured variable	8	Process temperature, Process pressure	60
Measuring range	8	Dielectric constant	62
Operating frequency	13	Mechanical construction	63
Transmitting power	13	Dimensions	63
Output	14	Weight	73
Output signal	14	Materials: GT18 housing	74
Signal on alarm	15	Materials: GT19 housing	75
Linearization	15	Materials: GT20 housing	76
Galvanic isolation	15	Materials: Antenna and process connection	77
Protocol-specific data	15	Materials: Weather protection cover	79
Power supply	20	Operability	80
Terminal assignment	20	Operating concept	80
Device plug connectors	27	Local operation	80
Supply voltage	28	Operation with remote display and operating module	
Power consumption	30	FHX50	81
Current consumption	30	Remote operation	81
Power supply failure	31	Integration in tank gauging system	85
Potential equalization	31	System integration via Fieldgate	86
Terminals	31	Certificates and approvals	87
Cable entries	31	CE mark	87
Cable specification	31	C-Tick symbol	87
Overvoltage protection	32	Ex approval	87
Performance characteristics	33	Dual seal according to ANSI/ISA 12.27.01	87
Reference operating conditions	33	Functional Safety	87
Maximum measured error	33	WHG	87
Measured value resolution	34	Sanitary compatibility	87
Reaction time	34	NACE MR 0175 / ISO 15156	87
Influence of ambient temperature	34	NACE MR 0103	88
Influence of gas layer	34	Pressure Equipment Directive	88
Gas phase compensation with external pressure sensor		Marine certificate (in preparation)	88
(PROFIBUS PA, FOUNDATION Fieldbus)	35	Radio standard EN302729-1/2	88
Installation	36	Radio standard EN302372-1/2	89
Installation conditions	36	FCC / Industry Canada	89
Measuring conditions	40	Japanese radio approval	89
Mounting cladded flanges	41	CRN approval	89
Installation in vessel (free space)	41	Track record	90
Installation in stilling well	45	Test, Certificate	91
Installation in bypass	47	Other standards and guidelines	92
Vessels with heat insulation	49	Ordering information	93
Environment	50	Ordering information	93
Ambient temperature range	50	3-point linearity protocol	94
Ambient temperature limits	50	5-point linearity protocol	95
Storage temperature	58	Customized parametrization	96
Climate class	58	Services	96
Altitude according to IEC61010-1 Ed.3	58	Accessories	97
		Device-specific accessories	97

Communication-specific accessories	101
Service-specific accessories	102
System components	102
Documentation	103
Standard documentation	103
Supplementary documentation	103
Safety Instructions (XA)	103
Registered trademarks	106
Patents	106







Important document information

Symbols









Safety symbols

Symbol	Meaning
	DANGER! This symbol alerts you to a dangerous situation. Failure to avoid this situation will result in serious or fatal injury.
	WARNING! This symbol alerts you to a dangerous situation. Failure to avoid this situation can result in serious or fatal injury.
	CAUTION! This symbol alerts you to a dangerous situation. Failure to avoid this situation can result in minor or medium injury.
	NOTE! This symbol contains information on procedures and other facts which do not result in personal injury.



Electrical symbols

Symbol	Meaning	Symbol	Meaning
	Direct current		Alternating current
	Direct current and alternating current		Ground connection A grounded terminal which, as far as the operator is concerned, is grounded via a grounding system.
	Protective ground connection A terminal which must be connected to ground prior to establishing any other connections.		Equipotential connection A connection that has to be connected to the plant grounding system: This may be a potential equalization line or a star grounding system depending on national or company codes of practice.

Symbols for certain types of information

Symbol	Meaning
	Permitted Procedures, processes or actions that are permitted.
	Preferred Procedures, processes or actions that are preferred.
	Forbidden Procedures, processes or actions that are forbidden.
	Tip Indicates additional information.
	Reference to documentation
	Reference to page
	Reference to graphic
	Visual inspection

Symbols in graphics

Symbol	Meaning
1, 2, 3 ...	Item numbers
1. 2. 3. ...	Series of steps
A, B, C, ...	Views
A-A, B-B, C-C, ...	Sections
	Hazardous area Indicates a hazardous area.
	Safe area (non-hazardous area) Indicates the non-hazardous area.

Function and system design

Measuring principle

The Micropilot is a "downward-looking" measuring system, operating based on the time-of-flight method (ToF). It measures the distance from the reference point (process connection) to the product surface. Radar impulses are emitted by an antenna, reflected off the product surface and received again by the radar system.

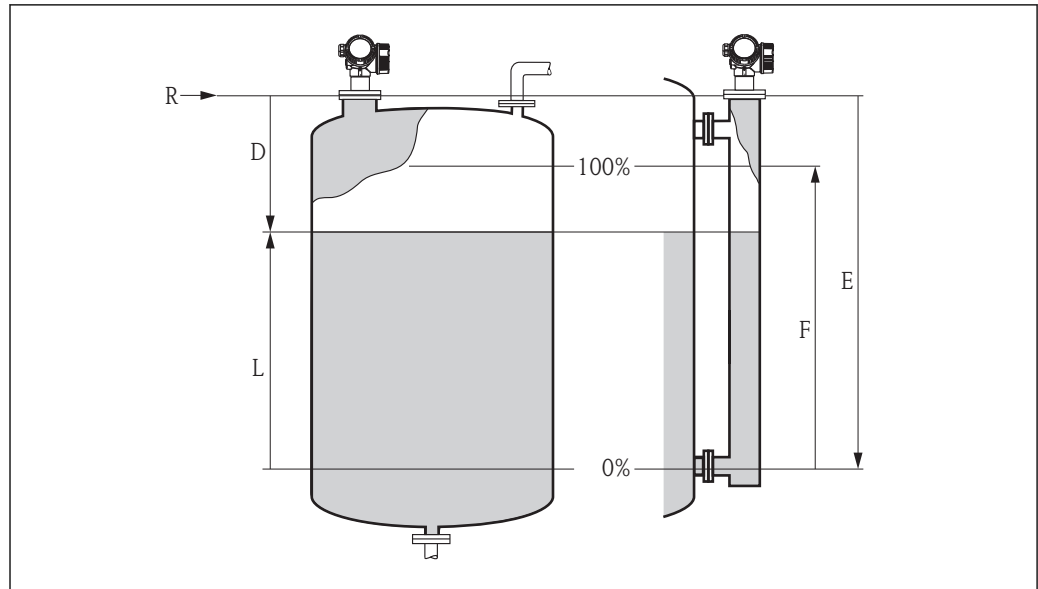

A0017871

1 Setup parameters of the Micropilot

- R* Reference point of the measurement (lower edge of the flange or threaded connection)
E Empty calibration (= zero)
F Full calibration (= span)
D Measured distance
L Level ($L = E - D$)

Input

The reflected radar impulses are received by the antenna and transmitted into the electronics. A microprocessor evaluates the signal and identifies the level echo caused by the reflection of the radar impulse at the product surface. The unambiguous signal identification is accomplished by the PulseMaster® eXact software together with the Multi-echo tracking algorithms, based on many years of experience with time-of-flight technology.

The distance D to the product surface is proportional to the time of flight t of the impulse:

$$D = c \cdot t / 2,$$

with c being the speed of light.

Based on the known empty distance E , the level L is calculated:

$$L = E - D$$

The reference point R of the measurement is located at the process connection. For details see the dimensional drawing:

- FMR51: → 64
- FMR52: → 70

The Micropilot is equipped with functions to suppress interference echoes. The user can activate these functions. Together with the multi-echo tracking algorithms they ensure that interference echoes (i.e. from edges and weld seams) are not interpreted as level echo.

Output

The Micropilot is commissioned by entering an empty distance "E" (=zero), a full distance "F" (=span) and application parameters which automatically adapt the instrument to the process conditions. For models with a current output, the factory adjustment for zero point "E" and span "F" is 4 mA and 20 mA. For digital outputs and the display module, the factory adjustment for zero point "E" and span "F" is 0 % and 100 %.

A linearization with max. 32 points, based on a table entered either manually or semi-automatically, can be activated locally or remotely. This function provides a measurement in engineering units and a linear output signal for spheres, horizontal cylindrical tanks and vessels with conical outlet.

Life cycle of the product

Engineering

- Universal measuring principle
- Measurement unaffected by medium properties
- Hardware and software developed according to SIL IEC 61508

Procurement

- Endress+Hauser being the world market leader in level measurement guarantees asset protection
- Worldwide support and service

Installation

- Special tools are not required
- Reverse polarity protection
- Modern, detachable terminals
- Main electronics protected by a separate connection compartment

Commissioning

- Fast, menu-guided commissioning in only a few steps on site or from the control room
- Plain text display in national languages reduces the risk of error or confusion
- Direct local access of all parameters
- Short instruction manual at the device

Operation

- Multi-echo tracking: Reliable measurement through self-learning echo-search algorithms taking into account the short-term and long-term history in order to check the found echoes for plausibility and to suppress interference echoes.
- Diagnostics in accordance with NAMUR NE107

Maintenance

- HistoROM: Data backup for instrument settings and measured values
- Exact instrument and process diagnosis to assist fast decisions with clear details concerning remedies
- Intuitive, menu-guided operating concept in national languages saves costs for training, maintenance and operation
- Cover of the electronics compartment can be opened in hazardous areas

Retirement

- Order code translation for subsequent models
- RoHS-conforming (Restriction of certain Hazardous Substances), unleaded soldering of electronic components
- Environmentally sound recycling concept

Input

Measured variable

The measured variable is the distance between the reference point and the product surface.

The level is calculated from this distance, taking into account the empty distance "E" entered by the user.

If required, the level can be converted into other variables (volume, mass) by means of a linearization (up to 32 points).

Measuring range

Maximum measuring range

Device	Maximum measuring range
FMR51 - standard version	40 m (131 ft)
FMR51 - with "Advanced dynamics" application package	70 m (230 ft)
FMR52 - standard version	40 m (131 ft)
FMR52 - with "Advanced dynamics" application package	60 m (197 ft)

Usable measuring range

The usable measuring range depends on the size of the antenna, the reflectivity of the medium, the mounting location and eventual interference reflections.

The following tables describe the groups of media as well as the achievable measuring range as a function of application and media group. If the dielectric constant of a medium is unknown, it is recommended to assume media group B to ensure a reliable measurement.

Media groups

Media groups	DK (ϵ_r)	Example
A	1.4 to 1.9	non-conducting liquids, e.g. liquefied gas ¹⁾
B	1.9 to 4	non-conducting liquids, e.g. benzene, oil, toluene, ...
C	4 to 10	e.g. concentrated acids, organic solvents, esters, aniline, alcohol, acetone, ...
D	> 10	conducting liquids, e.g. aqueous solutions, dilute acids and alkalis

1) Treat Ammonia NH₃ as a medium of group A.



Dielectric constants (DC values) for many important media are summarized in

For dielectric constants (DC values) of many important media refer to:

- the **DC Manual** by Endress+Hauser (CP01076F) by Endress+Hauser
- the **DC Values** App by Endress+Hauser (available for Android and iOS)

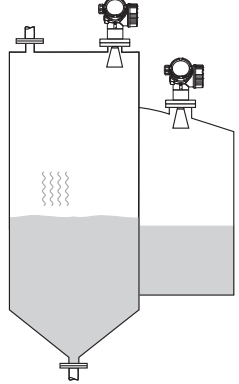
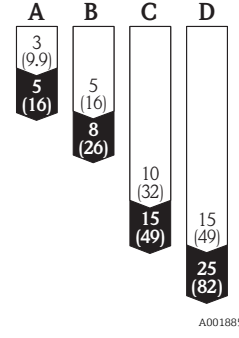
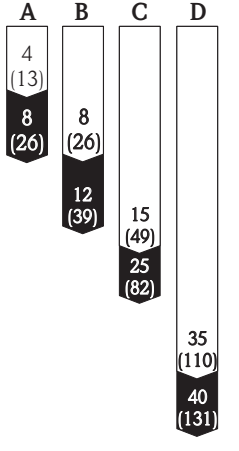
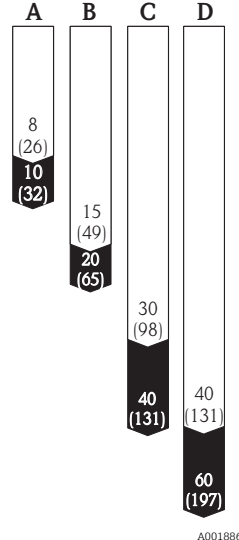
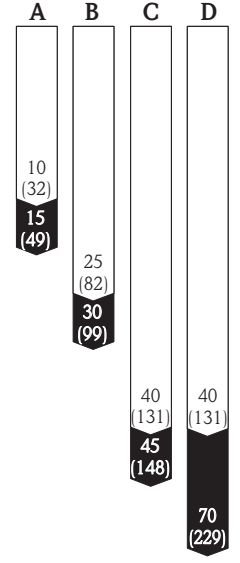
Device	Storage tank			
	 <p style="text-align: right;">A0018833</p> <p style="text-align: center;">Calm product surface (e.g. intermittent filling, filling from bottom, immersion tubes)</p>			
	Antenna size			
FMR51	40 mm (1½ in)	50 mm (2 in)	80 mm (3 in)	100 mm (4 in)
FMR52	-	50 mm (2 in)	80 mm (3 in)	-
	 <p style="text-align: right;">A0018858</p>	 <p style="text-align: right;">A0018859</p>	 <p style="text-align: right;">A0018860</p>	 <p style="text-align: right;">A0018862</p>
	Measuring range [m (ft)]			

Legend

□	Measuring range of the standard version
■	Measuring range for the "Advanced dynamics" application package (product structure: feature 540: "Application Package", Option EM: "Advanced dynamics")

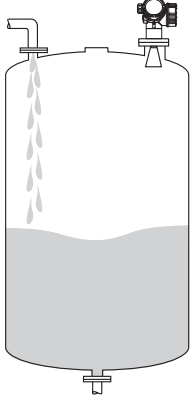
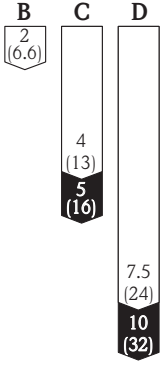
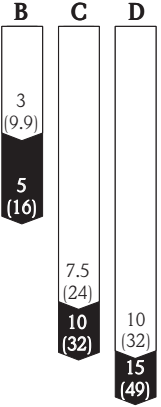
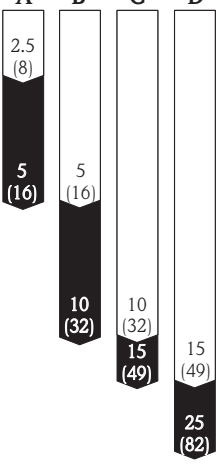
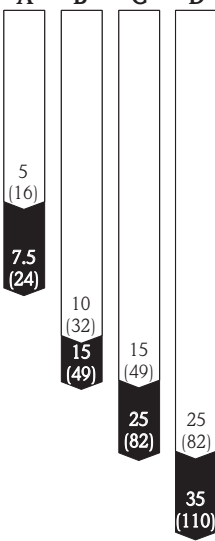
Device	Buffer tank			
	 <p data-bbox="1385 696 1439 712">A0018835</p> <p data-bbox="531 734 1121 766">Moving surfaces (e.g. continuous filling, from above, mixing jets)</p>			
	Antenna size			
FMR51	40 mm (1½ in)	50 mm (2 in)	80 mm (3 in)	100 mm (4 in)
FMR52	-	50 mm (2 in)	80 mm (3 in)	-
	 <p data-bbox="427 1283 478 1299">A0018863</p>	 <p data-bbox="834 1328 885 1344">A0018864</p>	 <p data-bbox="1106 1400 1157 1415">A0018865</p>	 <p data-bbox="1385 1478 1436 1494">A0018866</p>
	Measuring range [m (ft)]			



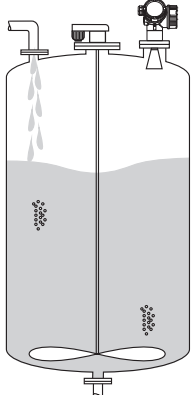
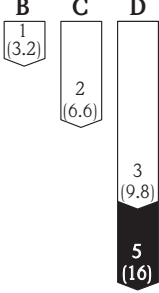
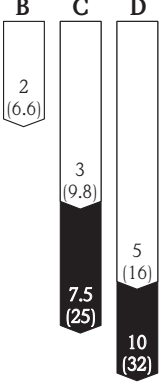
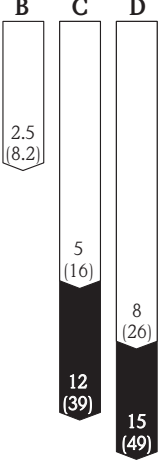
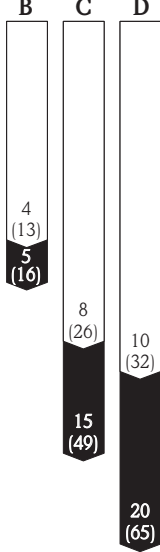

Legend

□	Measuring range of the standard version
■	Measuring range for the "Advanced dynamics" application package (product structure: feature 540: "Application Package", Option EM: "Advanced dynamics")

Device	Process tank with agitator			
	 <p style="text-align: right; font-size: small;">A0018837</p> <p style="text-align: center;">Turbulent surface (e.g. filling from above, agitators, baffles)</p>			
	Antenna size			
FMR51	40 mm (1½ in)	50 mm (2 in)	80 mm (3 in)	100 mm (4 in)
FMR52	-	50 mm (2 in)	80 mm (3 in)	-
	 <p style="text-align: right; font-size: x-small;">A0018867</p>	 <p style="text-align: right; font-size: x-small;">A0018868</p>	 <p style="text-align: right; font-size: x-small;">A0018869</p>	 <p style="text-align: right; font-size: x-small;">A0018870</p>
	Measuring range [m (ft)]			

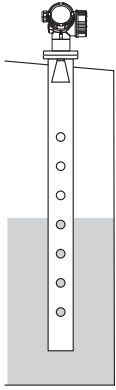
Legend

□	Measuring range of the standard version
■	Measuring range for the "Advanced dynamics" application package (product structure: feature 540: "Application Package", Option EM: "Advanced dynamics")

Device	Stilling well	Bypass
	 <p style="text-align: right; font-size: small;">A0018842</p>	 <p style="text-align: right; font-size: small;">A0018840</p>
	Antenna size	Antenna size
FMR51	40 to 100 mm (1½ ... 4 in)	40 to 100 mm (1½ ... 4 in)
FMR52	50 to 80 mm (2 ... 3 in)	50 to 80 mm (2 ... 3 in)
	<p style="text-align: center;">A, B, C, D</p>  <p style="text-align: right; font-size: small;">A0018851</p>	<p style="text-align: center;">C, D</p>  <p style="text-align: right; font-size: small;">A0018852</p>
Measuring range [m (ft)]		

Operating frequency

K-band (~ 26 GHz)

Up to 8 Micropilot transmitters can be installed in the same tank because the transmitter pulses are statistically coded.

Transmitting power

Distance	Average energy density in beam direction	
	Standard version	With "Advanced dynamics" application package ¹⁾
1 m (3.3 ft)	< 12 nW/cm ²	< 64 nW/cm ²
5 m (16 ft)	< 0.4 nW/cm ²	< 2.5 nW/cm ²

1) Product structure, feature 540: "Application package", option EM: "Advanced dynamics"

Output

Output signal

HART

Signal coding	FSK ± 0.5 mA over current signal
Data transmission rate	1 200 Bit/s
Galvanic isolation	Yes

PROFIBUS PA

Signal coding	Manchester Bus Powered (MBP)
Data transmission rate	31.25 kBit/s, voltage mode
Galvanic isolation	Yes

FOUNDATION Fieldbus

Signal coding	Manchester Bus Powered (MBP)
Data transmission rate	31.25 kBit/s, voltage mode
Galvanic isolation	Yes

Switch output

 For HART devices, the switch output is available as an option. See product structure, feature 20: "Power Supply, Output", option B: "2-wire; 4-20mA HART, switch output"

Devices with PROFIBUS PA and FOUNDATION Fieldbus always have a switch output.

Switch output	
Function	Open collector switching output
Switching behavior	Binary (conductive or non-conductive), switches when the programmable switch point is reached
Failure mode	non-conductive
Electrical connection values	$U = 10.4$ to $35 V_{DC}$, $I = 0$ to 40 mA
Internal resistance	$R_i < 880 \Omega$ The voltage drop at this internal resistance has to be taken into account on planning the configuration. For example, the resulting voltage at a connected relay must be sufficient to switch the relay.
Insulation voltage	floating, Insulation voltage $1\ 350 V_{DC}$ to power supply and $500 V_{AC}$ to ground
Switch point	freely programmable, separately for switch-on and switch-off point
Switching delay	freely programmable from 0 to 100 sec. , separately for switch-on and switch-off point
Number of switching cycles	corresponds to the measuring cycle
Signal source device variables	<ul style="list-style-type: none"> ▪ Level linearized ▪ Distance ▪ Terminal voltage ▪ Electronic temperature ▪ Relative echo amplitude ▪ Diagnostic values, Advanced diagnostics
Number of switching cycles	unlimited

Signal on alarm Depending on the interface, failure information is displayed as follows:

- Current output (for HART devices)
 - Failsafe mode selectable (in accordance with NAMUR Recommendation NE 43):
 - Minimum alarm: 3.6 mA
 - Maximum alarm (= factory setting): 22 mA
 - Failsafe mode with user-selectable value: 3.59 to 22.5 mA
- Local display
 - Status signal (in accordance with NAMUR Recommendation NE 107)
 - Plain text display
- Operating tool via digital communication (HART, PROFIBUS PA, FOUNDATION Fieldbus) or service interface (CDI)
 - Status signal (in accordance with NAMUR Recommendation NE 107)
 - Plain text display

Linearization The linearization function of the device allows the conversion of the measured value into any unit of length or volume. Linearization tables for calculating the volume in cylindrical tanks are pre-programmed. Other tables of up to 32 value pairs can be entered manually or semi-automatically.

Galvanic isolation All circuits for the outputs are galvanically isolated from each other.

Protocol-specific data

HART

Manufacturer ID	17 (0x11)
Device type ID	41 (0x28)
HART specification	6.0
Device description files (DTM, DD)	Information and files under: <ul style="list-style-type: none"> ■ www.endress.com ■ www.hartcomm.org
HART load	Min. 250 Ω
HART device variables	The measured values can be freely assigned to the device variables. <p>Measured values for PV (primary variable)</p> <ul style="list-style-type: none"> ■ Level linearized ■ Distance ■ Electronic temperature ■ Relative echo amplitude ■ Analog output adv. diagnostics <p>Measured values for SV, TV, FV (second, third and fourth variable)</p> <ul style="list-style-type: none"> ■ Level linearized ■ Distance ■ Terminal voltage ■ Electronic temperature ■ Absolute echo amplitude ■ Relative echo amplitude ■ Area of incoupling
Supported functions	<ul style="list-style-type: none"> ■ Burst mode ■ Additional transmitter status

Wireless HART data

Minimum start-up voltage	16 V
Start-up current	3.6 mA
Start-up time	40 s
Minimum operating voltage	12.3 V
Multidrop current	3.6 mA
Set-up time	1 s

PROFIBUS PA

Manufacturer ID	17 (0x11)
Ident number	0x1559
Profile version	3.02
GSD file	Information and files under:
GSD file version	<ul style="list-style-type: none"> ▪ www.endress.com ▪ www.profibus.org
Output values	<p>Analog Input:</p> <ul style="list-style-type: none"> ▪ Level linearized ▪ Distance ▪ Terminal voltage ▪ Electronic temperature ▪ Absolute echo amplitude ▪ Relative echo amplitude ▪ Analog output advanced diagnostics 1/2 <p>Digital Input:</p> <ul style="list-style-type: none"> ▪ Advanced diagnostic blocks ▪ Status output switch block
Input values	<p>Analog Output:</p> <ul style="list-style-type: none"> ▪ Analog value from PLC (for sensor block external pressure to compensate gas phase effects) ▪ Analog value from PLC to be indicated on the display <p>Digital Output:</p> <ul style="list-style-type: none"> ▪ Extended diagnostic block ▪ Level limiter ▪ Sensor block measurement on ▪ Sensor block save history on ▪ Status output
Supported functions	<ul style="list-style-type: none"> ▪ Identification & Maintenance Einfachste Geräteidentifizierung seitens des Leitsystems und des Typenschildes ▪ Automatic Ident Number Adoption GSD compatibility mode with respect to the preceding product Micropilot M FMR2xx ▪ Physical Layer Diagnostics Installation check of the PRFIBUS segment and the Micropilot FMR5x via the terminal voltage and telegram surveillance. ▪ PROFIBUS Up-/Download Up to 10 times faster writing and reading of parameters via PROFIBUS up-/download ▪ Condensed Status Simple and self-explanatory diagnostic information by categorization of occurring diagnostic messages.

FOUNDATION Fieldbus

Manufacturer ID	0x452B48
Device type	0x1028
Device Revision	0x01
DD Revision	Information and files can be found:
CFF Revision	<ul style="list-style-type: none"> ▪ www.endress.com ▪ www.fieldbus.org
Device Tester Version (ITK Version)	6.0.1
ITK Test Campaign Number	IT085300
Link Master (LAS) capable	yes
Link Master / Basic Device selectable	yes; default: Basic Device

Node address	Default: 247 (0xF7)
Features supported	Following methods are supported: <ul style="list-style-type: none"> ▪ Restart ▪ ENP Restart ▪ Setup ▪ Linearization ▪ Self Check
Virtual Communication Relationships (VCRs)	
Number of VCRs	44
Number of Link Objects in VFD	50
Permanent entries	1
Client VCRs	0
Server VCRs	10
Source VCRs	43
Sink VCRs	0
Subscriber VCRs	43
Publisher VCRs	43
Device Link Capabilities	
Slot time	4
Min. inter PDU delay	8
Max. response delay	20

Transducer Blocks

Block	Content	Output values
Setup Transducer Block	Contains all parameters for a standard commissioning procedure	<ul style="list-style-type: none"> ▪ Level or volume ¹⁾ (Channel 1) ▪ Distance (Channel 2)
Advanced Setup Transducer Block	Contains all parameters for a more detailed configuration of the device	no output values
Display Transducer Block	Contains all parameters for the configuration of the display module	no output values
Diagnostic Transducer Block	Contains diagnostic information	no output values
Advanced Diagnostic Transducer Block	Contains parameters for the Advanced Diagnostic	no output values
Expert Configuration Transducer Block	Contains parameters which require detailed knowledge of the functionalities of the device	no output values
Expert Information Transducer Block	Contains information about the state of the device	no output values
Service Sensor Transducer Block	Contains parameters which can only be operated by Endress+Hauser service personnel	no output values
Service Information Transducer Block	Contains information on the state of device which is relevant for service operations	no output values
Data Transfer Transducer Block	Contains parameters which allow to backup the device configuration in the display module and to restore it into the device. Access to these parameters is restricted to the Endress+Hauser service.	no output values

1) depending on the configuration of the block

Function Blocks

Block	Content	Number of permanent blocks	Number of instantiable blocks	Execution time	Functionality
Resource Block	The Resource Block contains all the data that uniquely identifies the field device. It is an electronic version of a nameplate of the device.	1	0	-	enhanced
Analog Input Block	The AI block takes the manufacturer's input data, selected by channel number, and makes it available to other function blocks at its output.	2	3	25 ms	enhanced
Discrete Input Block	The DI block takes a discrete input value (e.g. indication of an level limit), and makes it available to other function blocks at its output.	1	2	20 ms	standard
Mutiple Analog Output Block	This block is used to transfer analog data from the bus into the device	1	0	20 ms	standard
Mutiple Discrete Output Block	This block is used to transfer discrete data from the bus to the device.	1	0	20 ms	standard
PID Block	The PID block serves as proportional-integralderivative controller and is used almost universally to do closed-loop-control in the field including cascade and feedforward.	1	1	25 ms	standard
Arithmetic Block	This block is designed to permit simple use of popular measurement math functions. The user does not have to know how to write equations. The math algorithm is selected by name, chosen by the user for the function to be done.	1	1	25 ms	standard
Signal Characterizer Block	The signal characterizer block has two sections, each with an output that is a non-linear function of the respective input. The non-linear function is determined by a single look-up table with 21 arbitrary x-y pairs.	1	1	25 ms	standard
Input Selector Block	The input selector block provides selection of up to four inputs and generates an output based on the configured action. This block normally receives its inputs from AI blocks. The block performs maximum, minimum, middle, average and 'first good' signal selection.	1	1	25 ms	standard

Block	Content	Number of permanent blocks	Number of instantiable blocks	Execution time	Functionality
Integrator Block	The Integrator Function Block integrates a variable as a function of the time or accumulates the counts from a Pulse Input block. The block may be used as a totalizer that counts up until reset or as a batch totalizer that has a setpoint, where the integrated or accumulated value is compared to pre-trip and trip settings, generating discrete signals when these settings are reached.	1	1	25 ms	standard
Analog Alarm Block		1	1	25 ms	standard

 Up to 20 blocks can be instantiated in the device altogether, including the blocks already instantiated on delivery.

Power supply

Terminal assignment

2-wire: 4-20mA HART

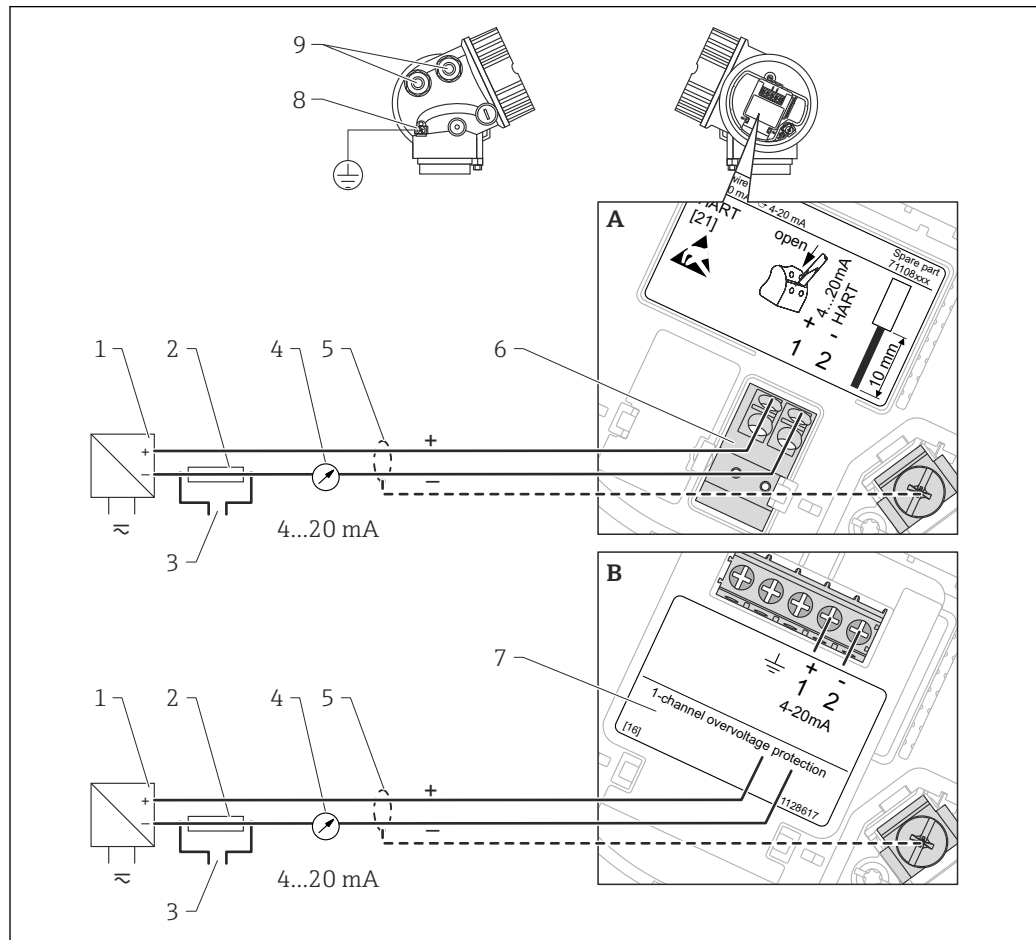

A0011294

2 Terminal assignment 2-wire; 4-20mA HART

- A Without integrated overvoltage protection
- B With integrated overvoltage protection
- 1 Active barrier with power supply (e.g. RN221N): Observe terminal voltage
- 2 HART communication resistor ($\geq 250 \Omega$): Observe maximum load
- 3 Connection for Commubox FXA195 or FieldXpert SFX350/SFX370 (via VIATOR Bluetooth modem)
- 4 Analog display device: Observe maximum load
- 5 Cable screen; observe cable specification
- 6 4-20mA HART (passive): Terminals 1 and 2
- 7 Overvoltage protection module
- 8 Terminal for potential equalization line
- 9 Cable entry

2-wire: 4-20mA HART, switch output

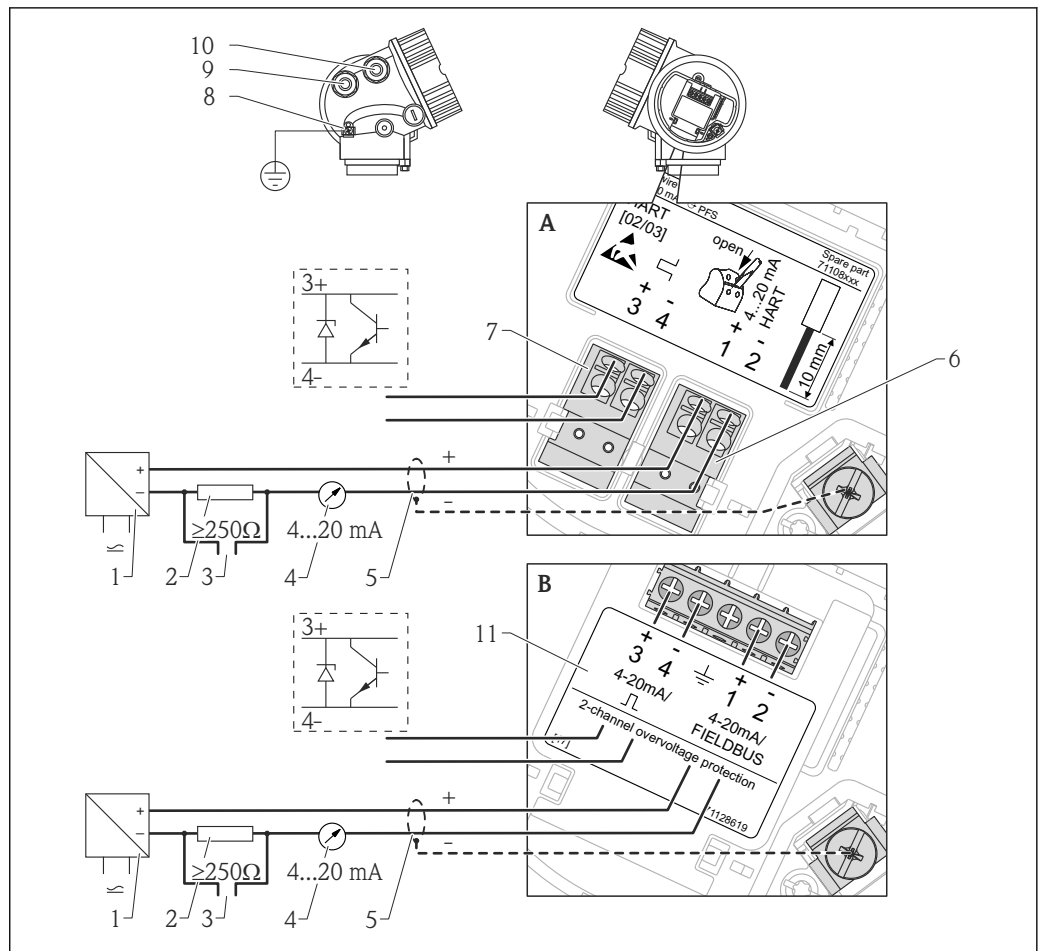

A0013759

3 Terminal assignment 2-wire; 4-20mA HART, switch output

A Without integrated overvoltage protection

B With integrated overvoltage protection

1 Active barrier with power supply (e.g. RN221N): Observe terminal voltage

2 HART communication resistor ($\geq 250 \Omega$): Observe maximum load

3 Connection for Commubox FXA195 or FieldXpert SFX350/SFX370 (via VIATOR Bluetooth modem)

4 Analog display device: Observe maximum load

5 Cable screen; observe cable specification

6 4-20mA HART (passive): Terminals 1 and 2

7 Switch output (open collector): Terminals 3 and 4

8 Terminal for potential equalization line

9 Cable entry for 4-20mA HART line

10 Cable entry for switch output line

11 Overvoltage protection module

2-wire: 4-20mA HART, 4-20mA

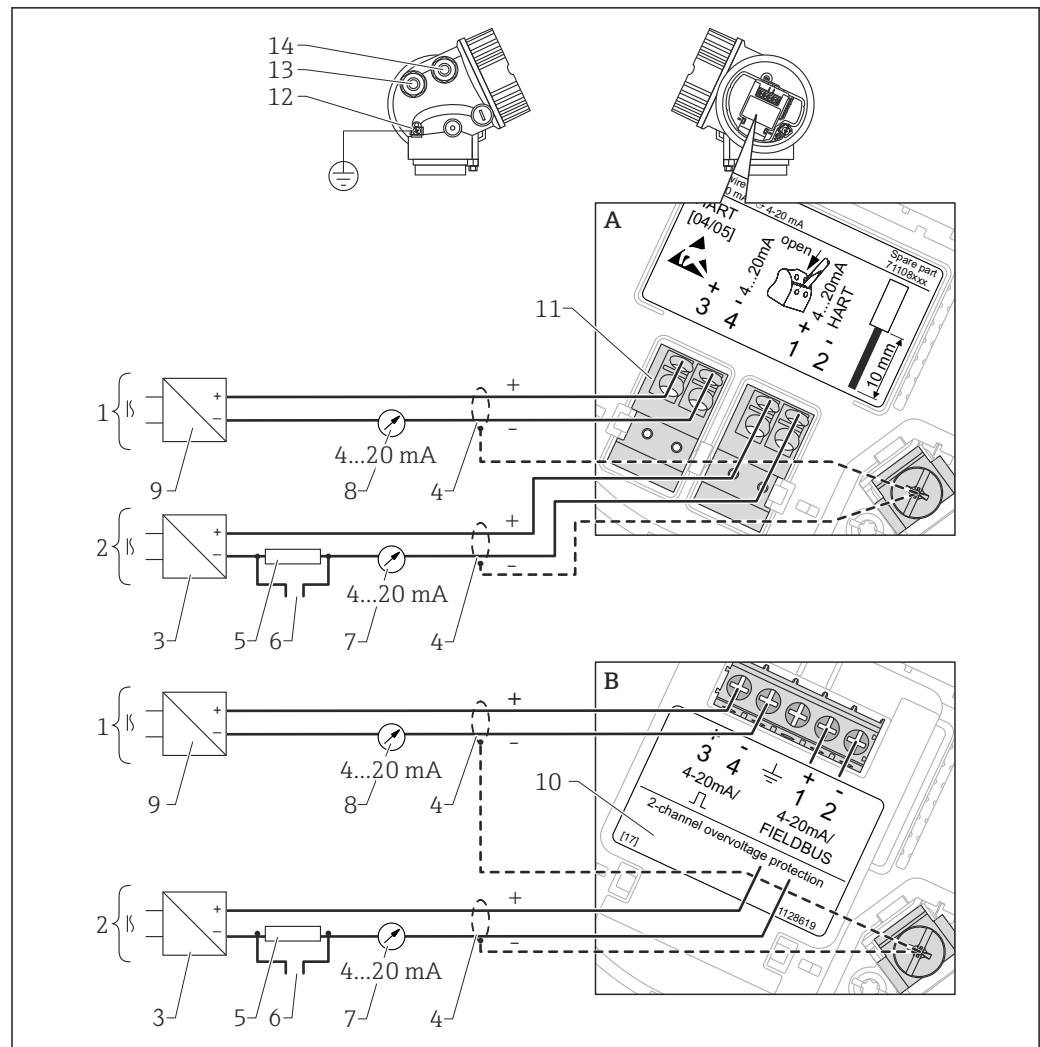

A0013923

4 Terminal assignment 2-wire, 4-20 mA HART, 4...20mA

- A Without integrated overvoltage protection
- B With integrated overvoltage protection
- 1 Connection current output 2
- 2 Connection current output 1
- 3 Supply voltage for current output 1 (e.g. RN221N); Observe terminal voltage
- 4 Cable screen; observe cable specification
- 5 HART communication resistor ($\geq 250 \Omega$); Observe maximum load
- 6 Connection for Commubox FXA195 or FieldXpert SFX350/SFX370 (via VIATOR Bluetooth modem)
- 7 Analog display device ; observe maximum load
- 8 Analog display device ; observe maximum load
- 9 Supply voltage for current output 2 (e.g. RN221N); Observe terminal voltage
- 10 Overvoltage protection module
- 11 Current output 2: Terminals 3 and 4
- 12 Terminal for the potential equalization line
- 13 Cable entry for current output 1
- 14 Cable entry for current output 2

i This version is also suited for single-channel operation. In this case, current output 1 (terminals 1 and 2) must be used.

4-wire: 4-20mA HART (10.4 to 48 V_{DC})

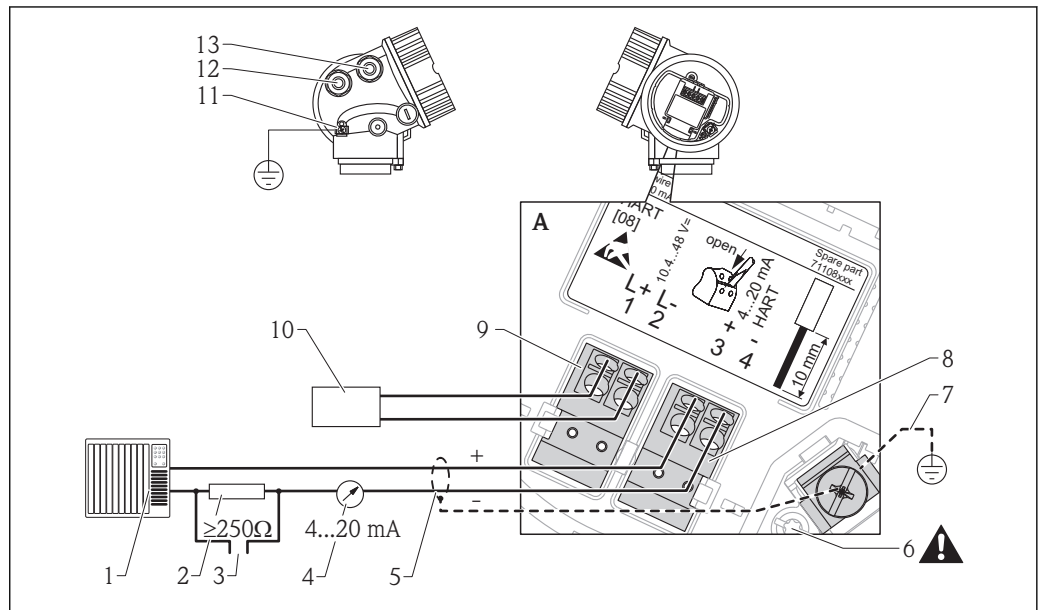

A0011340

5 Terminal assignment 4-wire; 4-20mA HART (10.4 to 48 VDC)

- 1 Evaluation unit, e.g. PLC
- 2 HART communication resistor ($\geq 250 \Omega$): Observe maximum load
- 3 Connection for Commubox FXA195 or FieldXpert SFX350/SFX370 (via VIATOR Bluetooth modem)
- 4 Analog display device: Observe maximum load
- 5 Signal cable including screening (if required), observe cable specification
- 6 Protective connection; do not disconnect!
- 7 Protective earth, observe cable specification
- 8 4...20mA HART (active): Terminals 3 and 4
- 9 Supply voltage: Terminals 1 and 2
- 10 Supply voltage: Observe terminal voltage, observe cable specification
- 11 Terminal for potential equalization
- 12 Cable entry for signal line
- 13 Cable entry for power supply

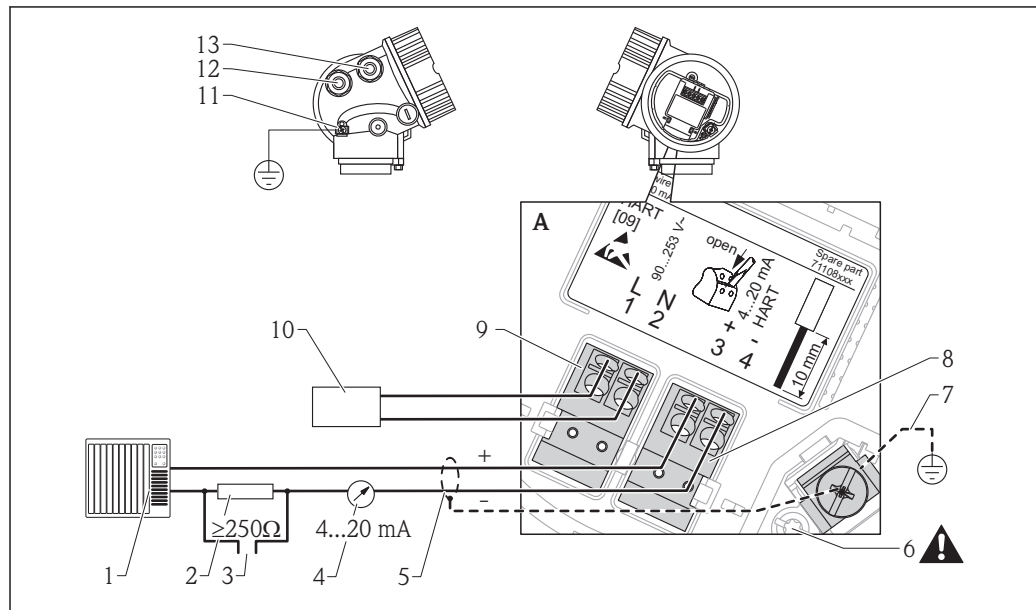
4-wire: 4-20mA HART (90 to 253 V_{AC})

A0018965

6 Terminal assignment 4-wire; 4-20mA HART (90 to 253 VAC)

- 1 Evaluation unit, e.g. PLC
- 2 HART communication resistor ($\geq 250 \Omega$): Observe maximum load
- 3 Connection for Commubox FXA195 or FieldXpert SFX350/SFX370 (via VIATOR Bluetooth modem)
- 4 Analog display device: Observe maximum load
- 5 Signal cable including screening (if required), observe cable specification
- 6 Protective connection; do not disconnect!
- 7 Protective earth, observe cable specification
- 8 4...20mA HART (active): Terminals 3 and 4
- 9 Supply voltage: Terminals 1 and 2
- 10 Supply voltage: Observe terminal voltage, observe cable specification
- 11 Terminal for potential equalization
- 12 Cable entry for signal line
- 13 Cable entry for power supply

CAUTION

To ensure electrical safety:

- ▶ Do not disconnect the protective connection (6).
- ▶ Disconnect the supply voltage before disconnecting the protective earth (7).

- i** Connect protective earth to the internal ground terminal (7) before connecting the supply voltage. If necessary, connect the potential matching line to the external ground terminal (11).
- i** In order to ensure electromagnetic compatibility (EMC): Do not only ground the device via the protective earth conductor of the supply cable. Instead, the functional grounding must also be connected to the process connection (flange or threaded connection) or to the external ground terminal.
- i** An easily accessible power switch must be installed in the proximity of the device. The power switch must be marked as a disconnecter for the device (IEC/EN61010).

PROFIBUS PA / FOUNDATION Fieldbus

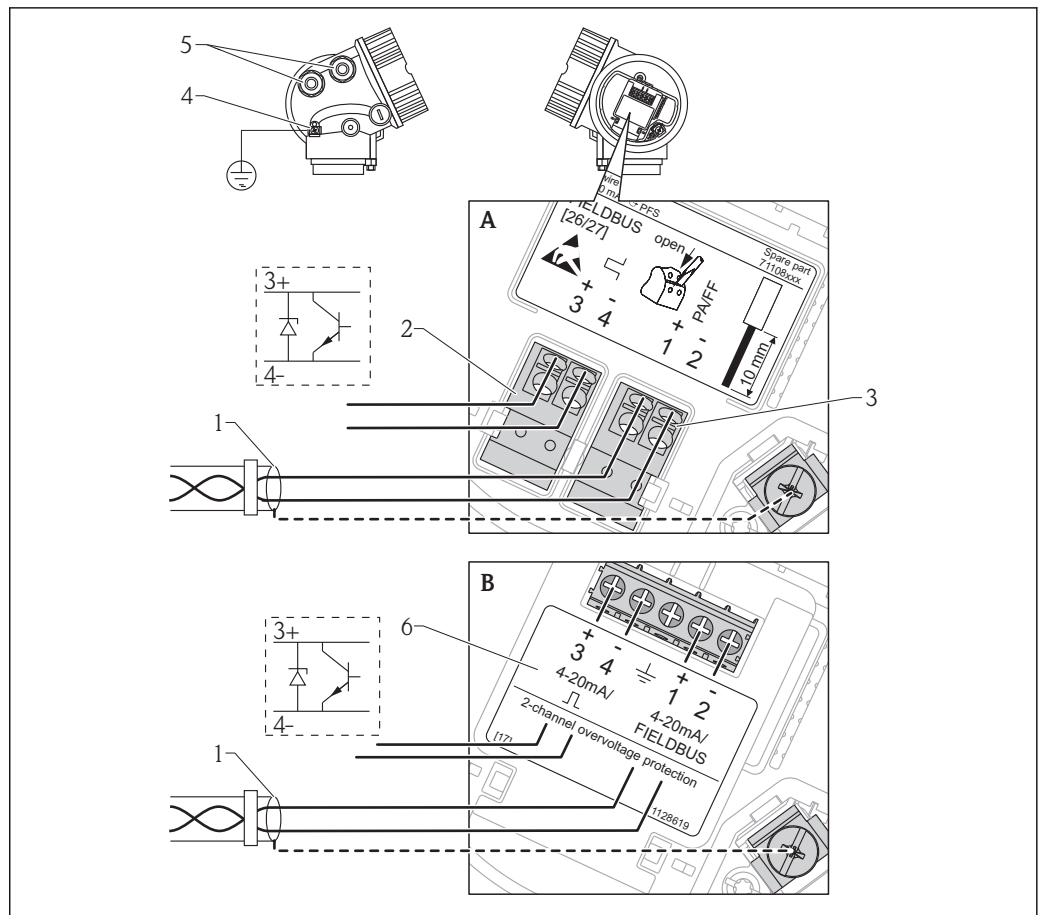

A0011341

7 Terminal assignment PROFIBUS PA / FOUNDATION Fieldbus

- A Without integrated overvoltage protection
- B With integrated overvoltage protection
- 1 Cable screen: Observe cable specifications
- 2 Switch output (open collector): Terminals 3 and 4
- 3 PROFIBUS PA / FOUNDATION Fieldbus: Terminals 1 and 2
- 4 Terminal for potential equalization line
- 5 Cable entries
- 6 Overvoltage protection module

Connection examples for the switch output

i For HART devices, the switch output is available as an option. See product structure, feature 20: "Power Supply, Output", option B: "2-wire; 4-20mA HART, switch output"

Devices with PROFIBUS PA and FOUNDATION Fieldbus always have a switch output.

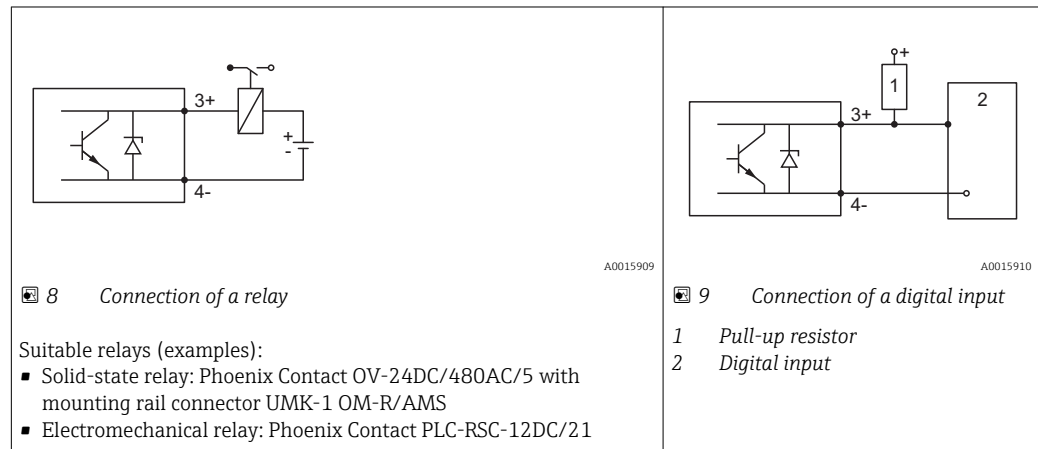

i For optimum interference immunity we recommend to connect an external resistor (internal resistance of the relay or Pull-up resistor) of $< 1\,000\ \Omega$.

Device plug connectors



For the versions with fieldbus plug connector (M12 or 7/8"), the signal line can be connected without opening the housing.

Pin assignment of the M12 plug connector

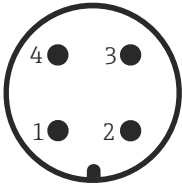
 <p style="text-align: right; font-size: small;">A0011175</p>	Pin	Meaning
	1	Signal +
	2	not connected
	3	Signal -
	4	Ground

Pin assignment of the 7/8" plug connector

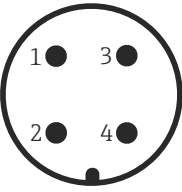
 <p style="text-align: right; font-size: small;">A0011176</p>	Pin	Meaning
	1	Signal -
	2	Signal +
	3	Not connected
	4	Screen

Supply voltage

An external power supply is required.

 Various supply units can be ordered from Endress+Hauser: see "Accessories" section →  102

2-wire, 4-20mA HART, passive

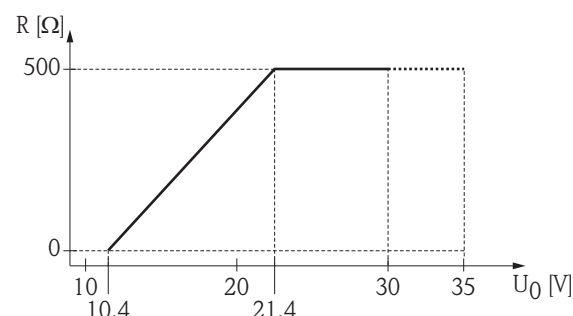
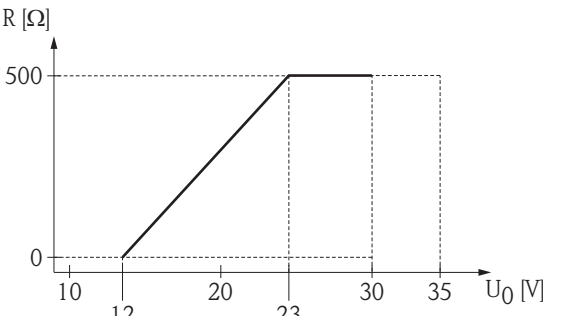
"Power Supply, Output" ¹⁾	"Approval" ²⁾	Terminal voltage U at the device	Maximum load R, depending on the supply voltage U ₀ at the supply unit
A: 2-wire; 4-20mA HART	<ul style="list-style-type: none"> ■ Non-Ex ■ Ex nA ■ Ex ic ■ CSA GP 	10.4 to 35 V ³⁾	 <p style="text-align: right; font-size: small;">A0017140</p>
	Ex ia / IS	10.4 to 30 V ³⁾	
	<ul style="list-style-type: none"> ■ Ex d(ia) / XP ■ Ex ic(ia) ■ Ex nA(ia) ■ Ex ta / DIP 	12 to 35 V ⁴⁾	 <p style="text-align: right; font-size: small;">A0019136</p>
	Ex ia + Ex d(ia) / IS + XP	12 to 30 V ⁴⁾	

- 1) Feature 020 of the product structure
- 2) Feature 010 of the product structure
- 3) For ambient temperatures T_a ≤ -20 °C (-4 °F) a minimum voltage of 15 V is required for the startup of the device at the MIN error current (3,6 mA). The startup current can be parametrized. If the device is operated with a fixed current I ≥ 5,5 mA (HART multidrop mode), a voltage of U ≥ 10,4 V is sufficient throughout the entire range of ambient temperatures.
- 4) For ambient temperatures T_a ≤ -20 °C (-4 °F) a minimum voltage of 16 V is required for the startup of the device at the MIN error current (3.6 mA).

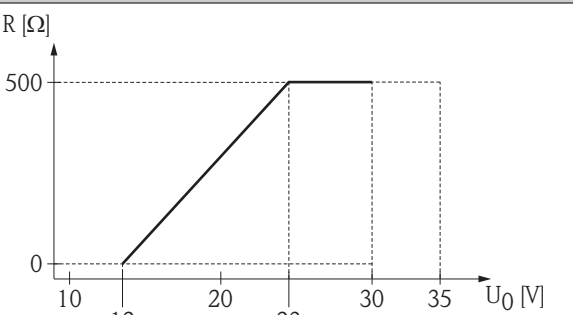
"Power Supply, Output" ¹⁾	"Approval" ²⁾	Terminal voltage U at the device	Maximum load R, depending on the supply voltage U ₀ at the supply unit
B: 2-wire; 4-20 mA HART, switch output	<ul style="list-style-type: none"> ■ Non-Ex ■ Ex nA ■ Ex nA(ia) ■ Ex ic ■ Ex ic(ia) ■ Ex d(ia) / XP ■ Ex ta / DIP ■ CSA GP 	12 to 35 V ³⁾	 <p style="text-align: right; font-size: small;">A0019136</p>
	<ul style="list-style-type: none"> ■ Ex ia / IS ■ Ex ia + Ex d(ia) / IS + XP 	12 to 30 V ³⁾	

- 1) Feature 020 of the product structure
- 2) Feature 010 of the product structure
- 3) For ambient temperatures T_a ≤ -30 °C (-22 °F) a minimum voltage of 16 V is required for the startup of the device at the MIN error current (3.6 mA).

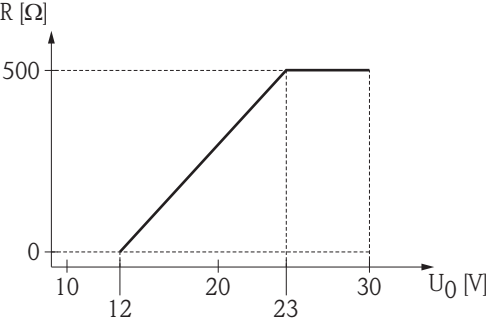
"Power Supply, Output" ¹⁾	"Approval" ²⁾	Terminal voltage U at the device	Maximum load R, depending on the supply voltage U ₀ at the supply unit
C: 2-wire; 4-20mA HART, 4-20mA	any	12 to 30 V ³⁾	 <p>The graph plots Maximum load R [Ω] on the y-axis (0 to 500) against supply voltage U₀ [V] on the x-axis (10 to 30). The load is 0 Ω for U₀ < 12 V. It increases linearly from 0 Ω at 12 V to 500 Ω at 23 V. It remains constant at 500 Ω for U₀ between 23 V and 30 V.</p>

A0017055

- 1) Feature 020 of the product structure
- 2) Feature 010 of the product structure
- 3) For ambient temperatures $T_a \leq -30\text{ °C}$ (-22 °F) a minimum voltage of 16 V is required for the startup of the device at the MIN error current (3.6 mA).

Polarity reversal protection	Yes
Admissible residual ripple at f = 0 to 100 Hz	$U_{SS} < 1\text{ V}$
Admissible residual ripple at f = 100 to 10000 Hz	$U_{SS} < 10\text{ mV}$

4-wire, 4-20mA HART, active

"Power supply; Output" ¹⁾	Terminal voltage	Maximum load R _{max}
K: 4-wire 90-253VAC; 4-20mA HART	90 to 253 V _{AC} (50 to 60 Hz), overvoltage category II	500 Ω
L: 4-wire 10,4-48VDC; 4-20mA HART	10.4 to 48 V _{DC}	

1) Feature 020 of the product structure

PROFIBUS PA, FOUNDATION Fieldbus

"Power supply; Output" ¹⁾	"Approval" ²⁾	Terminal voltage
E: 2-wire; FOUNDATION Fieldbus, switch output G: 2-wire; PROFIBUS PA, switch output	<ul style="list-style-type: none"> ▪ Non-Ex ▪ Ex nA ▪ Ex nA(ia) ▪ Ex ic ▪ Ex ic(ia) ▪ Ex d(ia) / XP ▪ Ex ta / DIP ▪ CSA GP 	9 to 32 V ³⁾
	<ul style="list-style-type: none"> ▪ Ex ia / IS ▪ Ex ia + Ex d(ia) / IS + XP 	9 to 30 V ³⁾

1) Feature 020 of the product structure

2) Feature 010 of the product structure

3) Input voltages up to 35 V will not spoil the device.

Polarity sensitive	No
FISCO/FNICO compliant according to IEC 60079-27	Yes

Power consumption

"Power supply; Output" ¹⁾	Power consumption
A: 2-wire; 4-20mA HART	< 0.9 W
B: 2-wire; 4-20mA HART, switch output	< 0.9 W
C: 2-wire; 4-20mA HART, 4-20mA	< 2 x 0.7 W
K: 4-wire 90-253VAC; 4-20mA HART	6 VA
L: 4-wire 10,4-48VDC; 4-20mA HART	1.3 W

1) Feature 020 of the product structure

Current consumption**HART**

Nominal current	3.6 to 22 mA, the start-up current for multidrop mode can be parametrized (is set to 3.6 mA on delivery)
Breakdown signal (NAMUR NE43)	adjustable: 3.59 to 22.5 mA

PROFIBUS PA

Nominal current	14 mA
Error current FDE (Fault Disconnection Electronic)	0 mA

FOUNDATION Fieldbus

Device basic current	15 mA
Error current FDE (Fault Disconnection Electronic)	0 mA

FISCO

U_i	17.5 V
I_i	550 mA
P_i	5.5 W
C_i	5 nF
L_i	10 μ H

Power supply failure

- Configuration is retained in the HistoROM (EEPROM).
- Error messages (incl. value of operated hours counter) are stored.

Potential equalization

No special measures for potential equalization are required.



If the device is designed for hazardous areas, observe the information in the documentation "Safety Instructions" (XA, ZD).

Terminals

- **Without integrated overvoltage protection**
Plug-in spring terminals for wire cross-sections 0.5 to 2.5 mm² (20 to 14 AWG)
- **With integrated overvoltage protection**
Screw terminals for wire cross-sections 0.2 to 2.5 mm² (24 to 14 AWG)

Cable entries

Connection of power supply and signal line

To be selected in feature 050 "Electrical connection"

- Gland M20; Material dependent on the approval:
 - For Non-Ex, ATEX, IECEx, NEPSI Ex ia/ic:
Plastics M20x1.5 for cable ϕ 5 to 10 mm (0.2 to 0.39 in)
 - For Dust-Ex, FM IS, CSA IS, CSA GP, Ex nA:
Metal M20x1.5 for cable ϕ 7 to 10 mm (0.28 to 0.39 in)¹⁾
 - For Ex d:
No gland available
- Thread
 - 1/2" NPT
 - G 1/2"
 - M20 x 1.5
- Plug M12 / Plug 7/8"
Only available for Non-Ex, Ex ic, Ex ia

Connection of remote display FHX50

Dependent on feature 030: "Display, Operation":

- "Prepared for display FHX50 + M12 connection":
M12 socket
- "Prepared for display FHX50 + custom connection":
Thread M16

Cable specification

- Minimum cross-section: dependent on terminals → 31
- For ambient temperature $T_U \geq 60^\circ\text{C}$ (140 °F): use cable for temperature $T_U + 20\text{ K}$.

1) The material of the gland is dependent on the housing type; GT18 (stainless steel housing): 316L (1.4404); GT19 (plastic housing) and GT20 (aluminum housing): nickel-coated brass (CuZn).

HART

- A normal device cable suffices if only the analog signal is used.
- A shielded cable is recommended if using the HART protocol. Observe grounding concept of the plant.
- For 4-wire devices: Standard device cable is sufficient for the power line.

PROFIBUS

Use a twisted, screened two-wire cable, preferably cable type A.

-  For further information on the cable specifications, see Operating Instructions BA00034S "Guidelines for planning and commissioning PROFIBUS DP/PA", PNO Guideline 2.092 "PROFIBUS PA User and Installation Guideline" and IEC61158-2 (MBP).

FOUNDATION Fieldbus

Endress+Hauser recommends using twisted, shielded two-wire cables.

-  For further information on the cable specifications, see Operating Instructions BA00013S "FOUNDATION Fieldbus Overview", FOUNDATION Fieldbus Guideline and IEC 61158-2 (MBP).

Overvoltage protection

If the measuring device is used for level measurement in flammable liquids which requires the use of overvoltage protection according to DIN EN 60079-14, standard for test procedures 60060-1 (10 kA, pulse 8/20 μ s), overvoltage protection has to be ensured by an integrated or external overvoltage protection module.

Integrated overvoltage protection

An integrated overvoltage protection module is available for 2-wire HART as well as PROFIBUS PA and FOUNDATION Fieldbus devices.

Product structure: Feature 610 "Accessory mounted", option NA "Overvoltage protection".

Technical data	
Resistance per channel	2 * 0.5 Ω max
Threshold DC voltage	400 to 700 V
Threshold impulse voltage	< 800 V
Capacitance at 1 MHz	< 1.5 pF
Nominal arrest impulse voltage (8/20 μ s)	10 kA

External overvoltage protection

HAW562 or HAW569 from Endress+Hauser are suited as external overvoltage protection.

-  For detailed information please refer to the following documents:
- HAW562: TI01012K
 - HAW569: TI01013K

Performance characteristics

Reference operating conditions

- Temperature = +24 °C (+75 °F) ±5 °C (±9 °F)
- Pressure = 960 mbar abs. (14 psia) ±100 mbar (±1.45 psi)
- Humidity = 60 % ±15 %
- Reflector: metal plate with a minimum diameter of 1 m (40 in)
- No major interference reflections inside the signal beam

Maximum measured error

Typical data under reference operating conditions: DIN EN 61298-2, percentage values in relation to the span.

Device	Value	Output	
		digital	analog ¹⁾
FMR51/FMR52 Standard version	Sum of non-linearity, nonrepeatability and hysteresis	± 2 mm (0.08 in)	± 0.02 %
	Offset/Zero	± 4 mm (0.2 in)	± 0.03 %
FMR51/FMR52 Version with application package "Advanced dynamics" ²⁾	Sum of non-linearity, nonrepeatability and hysteresis	± 3 mm (0.12 in)	± 0.02 %
	Offset/Zero	± 4 mm (0.2 in)	± 0.03 %

- 1) Only relevant for 4-20mA current output; add error of the analog value to the digital value.
- 2) Product structure: Feature 540 "Application Package", Option EM "Advanced dynamics"

Differing values in near-range applications

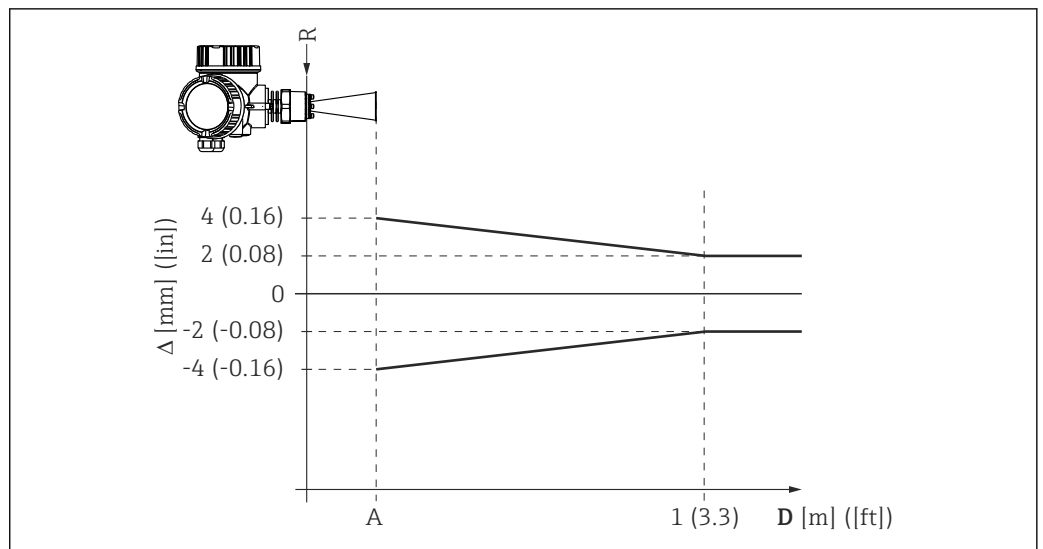

10 Maximum measured error in near-range applications; values for standard version

- Δ Maximum measured error
- A Lower edge of the antenna
- D Distance from the lower edge A of the antenna
- R Reference point of the distance measurement

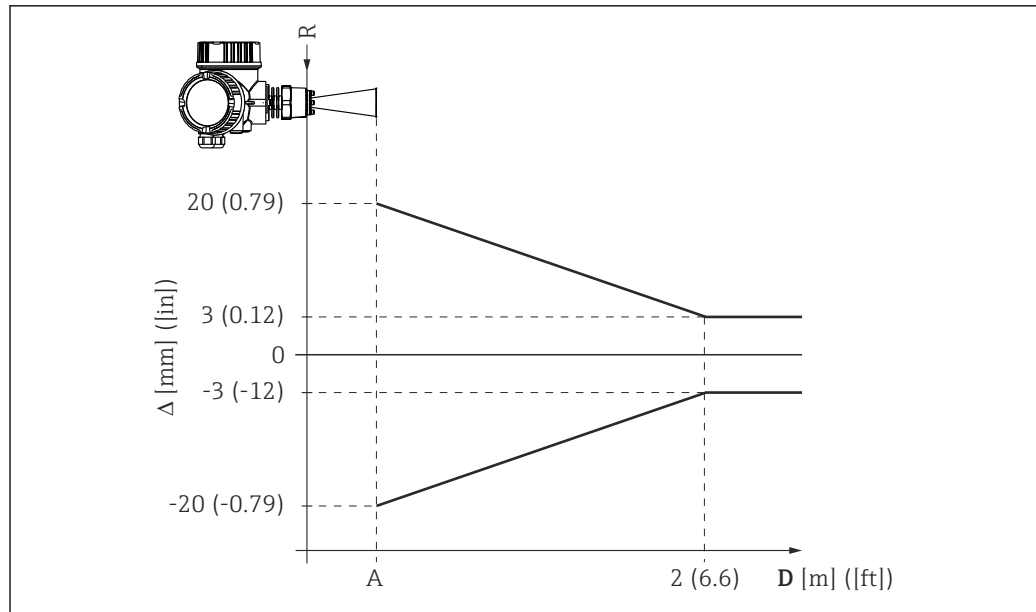

11 Maximum measured error in near-range applications; values for version with the "Advanced dynamics" application package

- Δ Maximum measured error
 A Lower edge of the antenna
 D Distance from the lower edge A of the antenna
 R Reference point of the distance measurement

Measured value resolution

Dead band according to EN61298-2:

- digital: 1 mm
- analog: 1 μ A

Reaction time

The reaction time can be parametrized. The following step response times (as per DIN EN 61298-2)²⁾ are valid if the damping is switched off:

Tank height	Sampling rate	Step response time
< 10 m (33 ft)	$\geq 3.6 \text{ s}^{-1}$	< 0.8 s
< 70 m (230 ft)	$\geq 2.2 \text{ s}^{-1}$	< 1 s

Influence of ambient temperature

The measurements are carried out in accordance with EN 61298-3

- Digital (HART, PROFIBUS PA, FOUNDATION Fieldbus):
 - Standard version: average $T_K = 2 \text{ mm}/10 \text{ K}$; maximum 5 mm
 - Version with advanced dynamics³⁾: average $T_K = 5 \text{ mm}/10 \text{ K}$; maximum 15 mm
- Analog (current output):
 - zero point (4 mA): average $T_K = 0.02 \text{ %}/10 \text{ K}$
 - span (20 mA): average $T_K = 0.05 \text{ %}/10 \text{ K}$

Influence of gas layer

High pressures reduce the propagation velocity of the measuring signals in the gas/vapor above the fluid. This effect depends on the kind of gas/vapor and of its temperature. This results in a systematic measuring error that gets bigger as the distance increases between the reference point of the measurement (flange) and the product surface. The following table illustrates this measured

2) According to DIN EN 61298-2 the response time is the time which passes after a sudden change of the input signal until the output signal for the first time assumes 90% of the steady-state value.

3) Feature 540 "Application Package", option EM

error for a few typical gases/vapors (with regard to distance; a positive value means that too large a distance is being measured):

Gas layer	Temperature		Pressure				
	°C	°F	1 bar (14,5 psi)	10 bar (145 psi)	50 bar (725 psi)	100 bar (1450 psi)	160 bar (2320 psi)
Air/ Nitrogen	20	68	0.00 %	0.22 %	1.2 %	2.4 %	3.89 %
	200	392	-0.01 %	0.13 %	0.74 %	1.5 %	2.42 %
	400	752	-0.02 %	0.08 %	0.52 %	1.1 %	1.70 %
Hydrogen	20	68	-0.01 %	0.10 %	0.61 %	1.2 %	2.00 %
	200	392	-0.02 %	0.05 %	0.37 %	0.76 %	1.23 %
	400	752	-0.02 %	0.03 %	0.25 %	0.53 %	0.86 %
Water (saturated steam)	100	212	0.02 %	-	-	-	-
	180	356	-	2.1 %	-	-	-
	263	505,4	-	-	8.6 %	-	-
	310	590	-	-	-	22 %	-
	364	687	-	-	-	-	41.8 %



When the pressure is known and constant, this measured error can, for example, be compensated by means of a linearization.

Gas phase compensation with external pressure sensor (PROFIBUS PA, FOUNDATION Fieldbus)

PROFIBUS devices can receive the signal of an external pressure sensor through the bus and use it to perform a pressure dependent time-of-flight correction. In the case of saturated steam in the temperature range from 100 to 350 °C (212 to 662 °f), for example, the measuring error of the distance measurement can be reduced by this method from up to 29 % (without compensation) to less than 3 % (with compensation).

Installation

Installation conditions

Mounting position

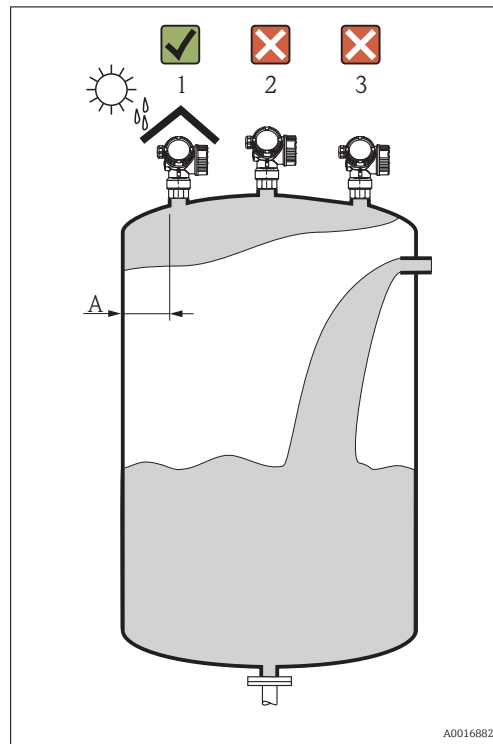

- Recommended distance **A** from wall to outer edge of nozzle: ~ 1/6 of tank diameter. Nevertheless the device should not be installed closer than 15 cm (5.91 in) to the tank wall.
- Not in the center (2), as interference can cause signal loss.
- Not above the fill stream (3).
- It is recommended to use a weather protection cover (1) in order to protect the device from direct sun or rain.

Vessel installations

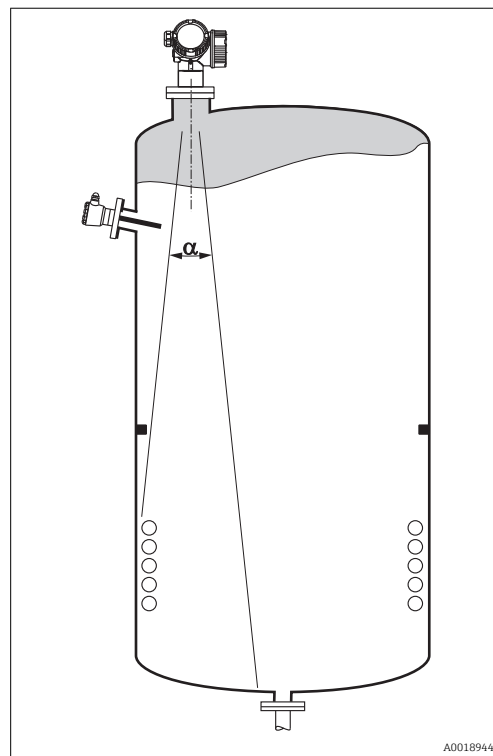

Avoid any installations (point level switches, temperature sensors, braces, vacuum rings, heating coils, baffles etc.) inside the signal beam. Take into account the beam angle → 38.

Reduction of interference echoes

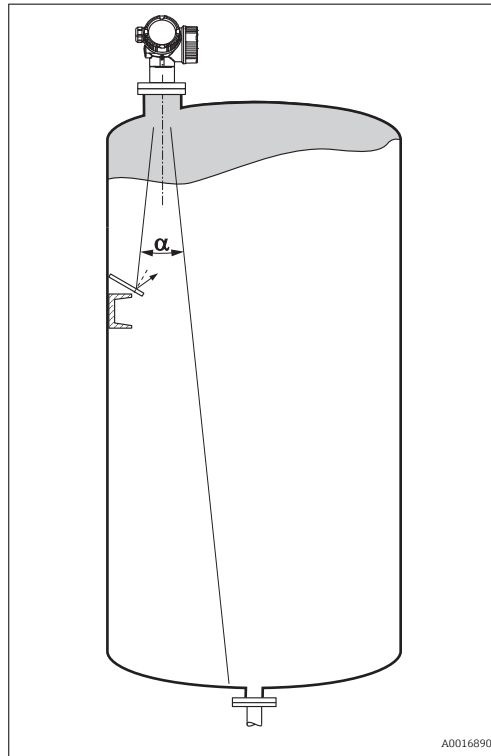

Metallic screens mounted at a slope spread the radar signal and can, therefore, reduce interference echoes.

Measurement in a plastic vessel

If the outer wall of the vessel is made of a non-conductive material (e.g. GRP), microwaves can also be reflected off interfering installations outside the signal beam (e.g. metallic pipes (1), ladders (2), grates (3), ...). Therefore, there should be no such interfering installations in the signal beam. Please contact Endress+Hauser for further information.

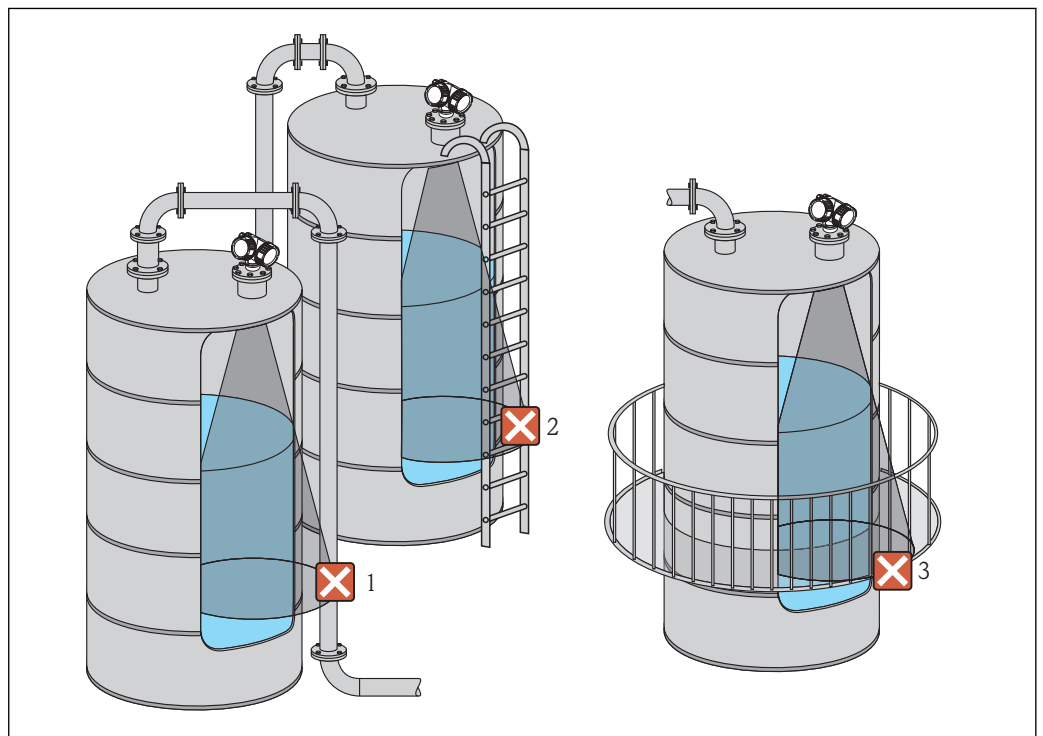

A0017123

Optimization options

- Antenna size
The bigger the antenna, the smaller the beam angle α and the fewer interference echoes
→ [38](#).
- Mapping
The measurement can be optimized by means of electronic suppression of interference echoes.
- Antenna alignment
Take into account the marker on the flange or threaded connection → [41](#) → [43](#).
- Stilling well
A stilling well can be applied to avoid interferences → [45](#).
- Metallic screens mounted at a slope
They spread the radar signals and can, therefore, reduce interference echoes.

Beam angle

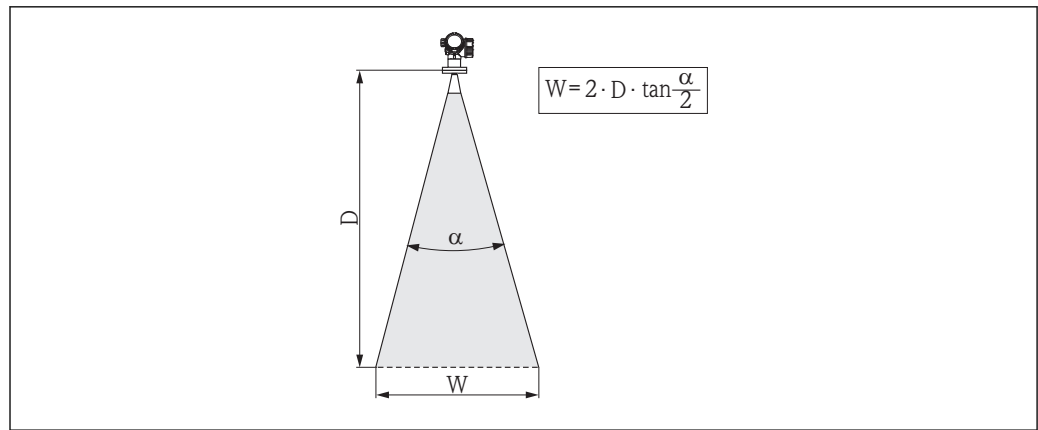

[12](#) Relationship between beam angle α , distance D and beamwidth diameter W

The beam angle is defined as the angle α where the energy density of the radar waves reaches half the value of the maximum energy density (3-dB-width). Microwaves are also emitted outside the signal beam and can be reflected off interfering installations.

Beam diameter **W** as a function of beam angle **α** and measuring distance **D**:

FMR51				
Antenna size	40 mm (1½ in)	50 mm (2 in)	80 mm (3 in)	100 mm (4 in)
Beam angle α	23°	18°	10°	8°
Measuring distance (D)	Beamwidth diameter W			
3 m (9.8 ft)	1.22 m (4 ft)	0.95 m (3.1 ft)	0.53 m (1.7 ft)	0.42 m (1.4 ft)
6 m (20 ft)	2.44 m (8 ft)	1.9 m (6.2 ft)	1.05 m (3.4 ft)	0.84 m (2.8 ft)
9 m (30 ft)	3.66 m (12 ft)	2.85 m (9.4 ft)	1.58 m (5.2 ft)	1.26 m (4.1 ft)
12 m (39 ft)	4.88 m (16 ft)	3.80 m (12 ft)	2.1 m (6.9 ft)	1.68 m (5.5 ft)
15 m (49 ft)	6.1 m (20 ft)	4.75 m (16 ft)	2.63 m (8.6 ft)	2.10 m (6.9 ft)
20 m (66 ft)	8.14 m (27 ft)	6.34 m (21 ft)	3.50 m (11 ft)	2.80 m (9.2 ft)
25 m (82 ft)	10.17 m (33 ft)	7.92 m (26 ft)	4.37 m (14 ft)	3.50 m (11 ft)
30 m (98 ft)	-	9.50 m (31 ft)	5.25 m (17 ft)	4.20 m (14 ft)
35 m (115 ft)	-	11.09 m (36 ft)	6.12 m (20 ft)	4.89 m (16 ft)
40 m (131 ft)	-	12.67 m (42 ft)	7.00 m (23 ft)	5.59 m (18 ft)
45 m (148 ft)	-	-	7.87 m (26 ft)	6.29 m (21 ft)
60 m (197 ft)	-	-	10.50 m (34 ft)	8.39 m (28 ft)
70 m (230 ft)	-	-	-	9.79 m (32 ft)

FMR52		
Antenna size	50 mm (2 in)	80 mm (3 in)
Beam angle α	18°	10°
Measuring distance (D)	Beamwidth diameter W	
3 m (9.8 ft)	0.95 m (3.1 ft)	0.53 m (1.7 ft)
6 m (20 ft)	1.9 m (6.2 ft)	1.05 m (3.4 ft)
9 m (30 ft)	2.85 m (9.4 ft)	1.58 m (5.2 ft)
12 m (39 ft)	3.80 m (12 ft)	2.1 m (6.9 ft)
15 m (49 ft)	4.75 m (16 ft)	2.63 m (8.6 ft)
20 m (66 ft)	6.34 m (21 ft)	3.50 m (11 ft)
25 m (82 ft)	7.92 m (26 ft)	4.37 m (14 ft)
30 m (98 ft)	9.50 m (31 ft)	5.25 m (17 ft)
35 m (115 ft)	11.09 m (36 ft)	6.12 m (20 ft)
40 m (131 ft)	12.67 m (42 ft)	7.00 m (23 ft)
45 m (148 ft)	-	7.87 m (26 ft)
60 m (197 ft)	-	10.50 m (34 ft)

Measuring conditions

- In case of **boiling surfaces, bubbling** or tendency for **foaming** use FMR53 or FMR54. Depending on its consistence, foam can either absorb microwaves or reflect them off the foam surface. Measurement is possible under certain conditions. For FMR50, FMR51 and FMR52, the additional option "Advanced dynamics" is recommended in these cases (feature 540: "Application Package", option EM).
- In case of heavy **steam development** or **condensate**, the maximum measuring range of FMR50, FMR51 and FMR52 may decrease depending on density, temperature and composition of the steam → use FMR53 or FMR54.
- For the measurement of absorbing gases such as **ammonia NH₃** or some **fluorocarbons** ⁴⁾, please use Levelflex or Micropilot FMR54 in a stilling well.
- The measuring range begins, where the beam hits the tank bottom. Particularly with dish bottoms or conical outlets the level cannot be detected below this point.
- For stilling well applications, the zero should be positioned at the end of the tube, as the electromagnetic waves do not propagate completely outside the tube. It must be taken into account that the accuracy may be reduced in the area **C**. In order to guarantee the required accuracy in these cases, it is recommended to position the zero-point at a distance **C** above the end of the tube (see figure).
- In case of media with a low dielectric constant ($\epsilon_r = 1.5$ to 4) ⁵⁾ the tank bottom can be visible through the medium at low levels (low height **C**). Reduced accuracy has to be expected in this range. If this is not acceptable, we recommend positioning the zero point at a distance **C** (see figure) above the tank bottom in these applications.
- In principle it is possible to measure up to the tip of the antenna with FMR51, FMR53 and FMR54. However, due to considerations regarding corrosion and build-up, the end of the measuring range should not be chosen any closer than **A** (see figure) to the tip of the antenna.
- When using FMR54 with planar antenna, especially for media with low dielectric constants, the end of the measuring range should not be closer than **A: 1 m (3.28 ft)** to the flange.
- The smallest possible measuring range **B** depends on the antenna version (see figure).
- The tank height should be at least **H** (see table).

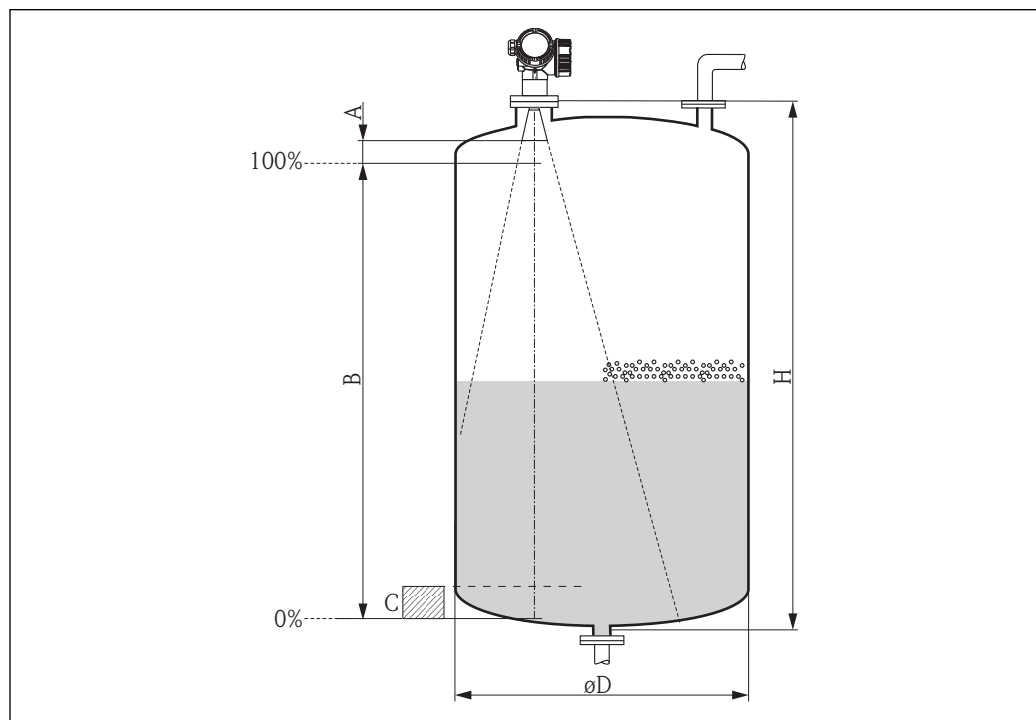

A0018872

Device	A [mm (in)]	B [m (ft)]	C [mm (in)]	H [m (ft)]
FMR51	50(1.97)	> 0.2 (0.7)	50 to 250 (1.97 to 9.84)	> 0.3 (1.0)
FMR52	200(7.87)			

4) Affected compounds are e.g. R134a, R227, Dymel 152a.

5) Dielectric constants of important media commonly used in various industries are summarized in the DC manual (CP01076F) and in the Endress+Hauser "DC Values App" (available for Android and iOS).

Mounting cladded flanges



- Use flange screws according to the number of flange holes.
- Tighten the screws with the required torque (see table).
- Retighten the screws after 24 hours or after the first temperature cycle.
- Depending on process pressure and process temperature check and retighten the screws at regular intervals.

Flange size	Number of screws	Recommended torque [Nm]	
		minimum	maximum
EN			
DN50/PN16	4	45	65
DN80/PN16	8	40	55
DN100/PN16	8	40	60
DN150/PN16	8	75	115
ASME			
2"/150lbs	4	40	55
3"/150lbs	4	65	95
4"/150lbs	8	45	70
6"/150lbs	8	85	125
JIS			
10K 50A	4	40	60
10K 80A	8	25	35
10K 100A	8	35	55
10K 100A	8	75	115

Installation in vessel (free space)

Horn antenna (FMR51)

Alignment

- Align the antenna vertically to the product surface.
The maximum range may be reduced if the horn antenna is not vertically aligned.
- A marking at the flange (somewhere between the flange holes) or the boss enables alignment of the antenna. This marking must be aligned towards the tank wall as well as possible.

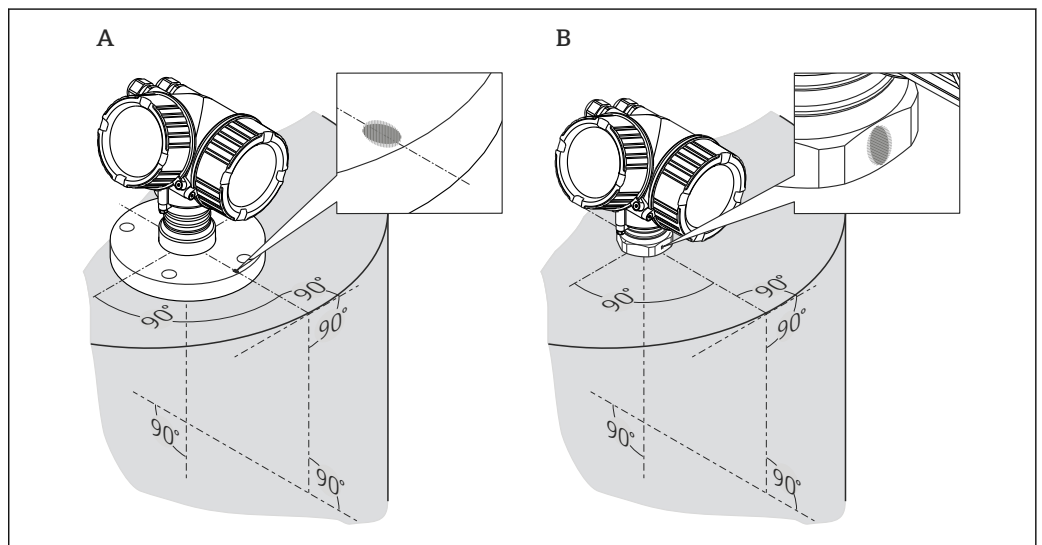

A0018974



Depending on the device version the marking may be a circle or two short parallel lines.

Nozzle mounting

For optimum measurement, the tip of the antenna should extend below the nozzle. Depending on the antenna size this is achieved by the following maximum nozzle heights:

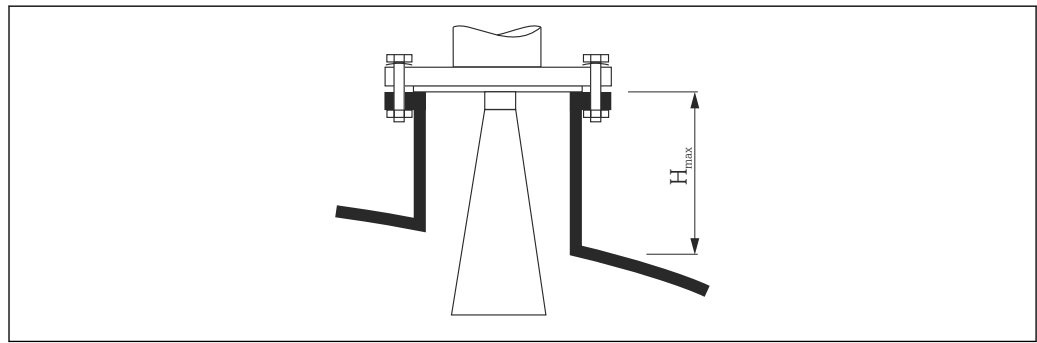

A0016820

13 Nozzle height for horn antenna (FMR51)

Antenna ¹⁾	Maximum nozzle height H_{max}
BA: Horn 40mm/1-1/2"	85 mm (3.35 in)
BB: Horn 50mm/2"	115 mm (4.53 in)
BC: Horn 80mm/3"	210 mm (8.27 in)
BD Horn 100mm/4"	280 mm (11.0 in)

1) Feature 070 of the product structure

Conditions for longer nozzles

If the medium has good reflective properties, higher nozzles can be accepted. In this case the maximum nozzle height, H_{max} , is dependent on the nozzle diameter, D :

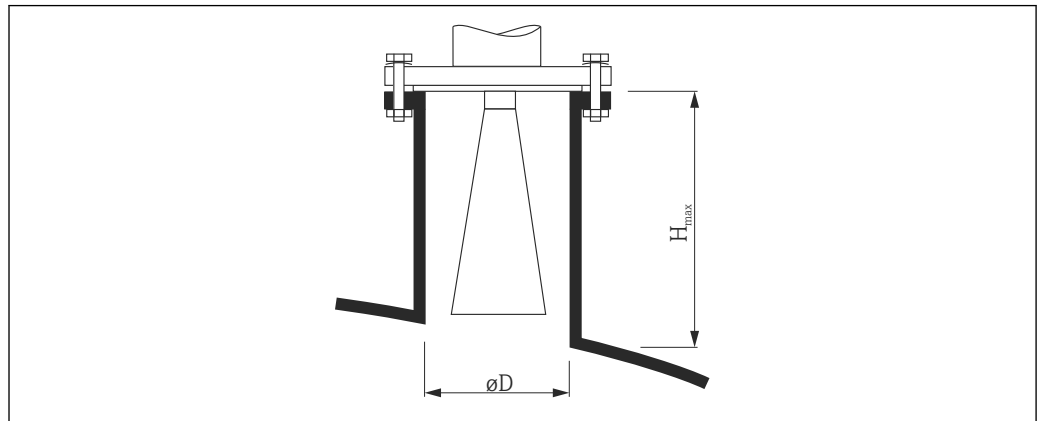

A0023611

Nozzle diameter D	Maximum nozzle height H_{max}	Recommended antenna ¹⁾
40 mm (1.5 in)	100 mm (3.9 in)	BA: Horn 40mm/1-1/2"
50 mm (2 in)	150 mm (5.9 in)	BB: Horn 50mm/2"
80 mm (3 in)	250 mm (9.8 in)	BC: Horn 80mm/3"

Nozzle diameter D	Maximum nozzle height H_{max}	Recommended antenna ¹⁾
100 mm (4 in)	500 mm (19.7 in)	BD: Horn 100mm/4"
150 mm (6 in)	800 mm (31.5 in)	BD: Horn 100mm/4"

1) Feature 070 of the product structure

- i** If the antenna doesn't extend below the nozzle, observe the following:
- The nozzle end must be smooth and free of burrs. If possible its edge should be rounded.
 - An interference echo suppression must be performed.
 - Please contact Endress+Hauser for applications with higher nozzles than those indicated in the table.
- i** For mounting in high nozzles the device is available in a version with an antenna extension of up to 1 000 mm (39.4 in) ⁶⁾
- The antenna extension may cause interference echoes in the near range. In this case it may occur that the maximum measurable level is reduced.

Threaded connection

- i** For devices with a threaded connection it may be necessary - depending on the antenna size - to unmount the horn before fastening the device and to mount it again afterwards.
- Tighten with the hexagonal nut only.
 - Tool : 55 mm hexagonal wrench
 - Maximum permissible torque: 60 Nm (44 lbf ft)

Measurement from the outside through plastic walls (FMR50/FMR51)

- Dielectric constant of the medium: $\epsilon_r > 10$
- If possible, use an antenna 100 mm (4 in).
- The distance from the lower edge of the antenna to the tank ceiling should be about 100 mm (4 in).
- If possible, avoid mounting locations where condensation or build-up might occur.
- In case of outdoor mounting, the space between antenna and vessel has to be protected from the elements.
- Do not mount any potential reflectors (e.g. pipes) outside the tank in the signal beam.

Suitable thickness of the tank ceiling:

Penetrated material	PE	PTFE	PP	Perspex
DK / ϵ_r	2.3	2.1	2.3	3.1
Optimum thickness ¹⁾	3.8 mm (0.15 in)	4.0 mm (0.16 in)	3.8 mm (0.15 in)	3.3 mm (0.13 in)

1) Other possible values for the thickness are multiples of the values listed (e.g. for PE: 7,6 mm (0.3 in), 11,4 mm (0.45 in))

Horn antenna, flush mount (FMR52)

Alignment

- Align the antenna vertically to the product surface.
The maximum range may be reduced if the horn antenna is not vertically aligned.
- A marking at the flange (somewhere between the flange holes) or the boss enables alignment of the antenna. This marking must be aligned towards the tank wall as well as possible.

6) Feature 610 "Accessory mounted" of the product structure.

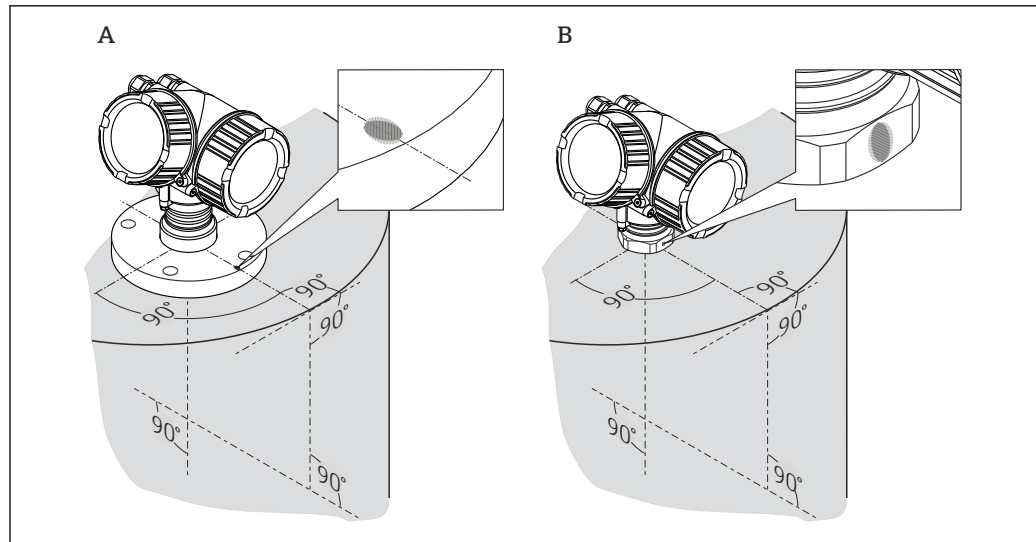

A0018974

i Depending on the device version the marking may be a circle or two short parallel lines.

Nozzle mounting

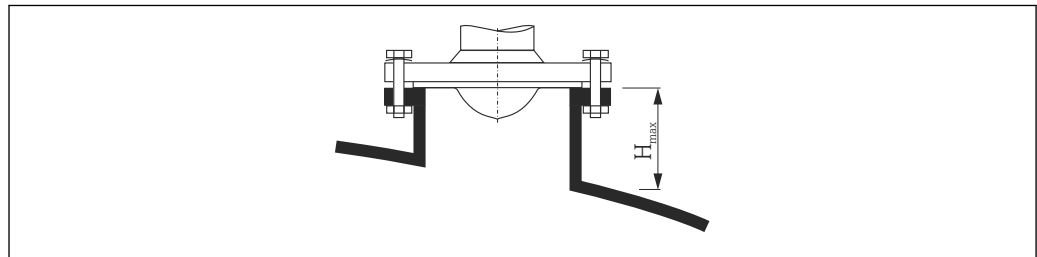

A0016819

14 Nozzle height for horn antenna, flush mount (FMR52)

Antenna ¹⁾	Maximum nozzle height H_{max}
BO: Horn 50mm/2"	500 mm (19.7 in)
BP: Horn 80mm/3"	500 mm (19.7 in)

1) Feature 070 of the product structure

i Please contact Endress+Hauser for applications with higher nozzle.

- i** For flanges with PTFE cladding: Observe the notes on the mounting of cladded flanges → 41.
- Usually, the PTFE flange cladding also serves as a seal between the nozzle and the device flange.

Installation in stilling well

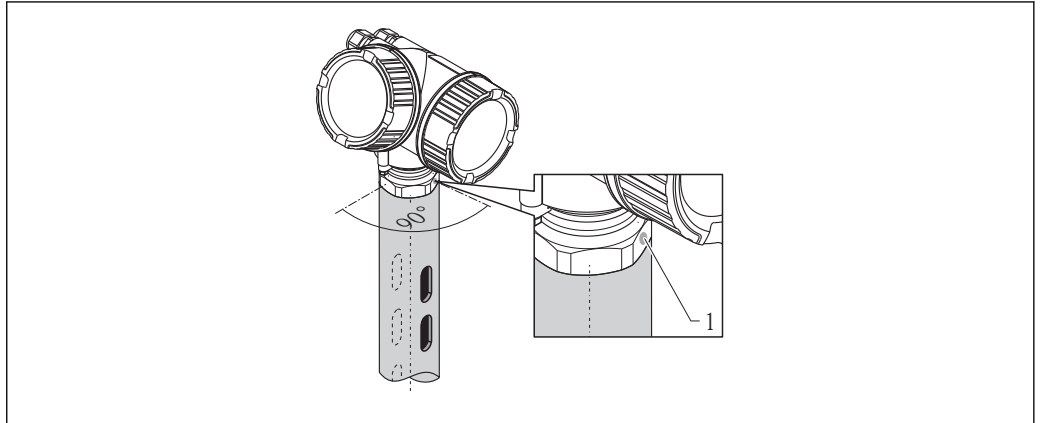

A0016841

15 Installation in stilling well

1 Marking for antenna alignment

- For horn antenna: Align the marking towards the slots of the stilling well.
- Measurements can be performed through an open full bore ball valve without any problems.
- After mounting, the housing can be turned 350° in order to facilitate access to the display and the terminal compartment.

Recommendations for the stilling well

- Metal (no enamel coating; plastic on request).
- Constant diameter.
- Diameter of stilling well not larger than antenna diameter.
- Diameter difference between horn antenna and inner diameter of the stilling well as small as possible.
- Weld seam as smooth as possible and on the same axis as the slots.
- Slots offset 180° (not 90°).
- Slot width or diameter of holes max. 1/10 of pipe diameter, de-burred. Length and number do not have any influence on the measurement.
- Select horn antenna as big as possible. For intermediate sizes (e.g. 180 mm (7 in)) select next larger antenna and adapt it mechanically (for horn antennas)
- At any transition (i.e. when using a ball valve or mending pipe segments), no gap may be left exceeding 1 mm (0.04 in).
- The stilling well must be smooth on the inside (average roughness $R_z \leq 6.3 \mu\text{m}$ (248 μin)). Use extruded or parallel welded metal pipe. An extension of the pipe is possible with welded flanges or pipe sleeves. Flange and pipe have to be properly aligned at the inside.
- Do not weld through the pipe wall. The inside of the stilling well must remain smooth. In case of unintentional welding through the pipe, the weld seam and any unevenness on the inside need to be carefully removed and smoothened. Otherwise, strong interference echoes will be generated and material build-up will be promoted.
- In the case of smaller nominal widths flanges must be welded to the pipe such that they allow for a correct orientation (marker aligned toward slots).

Examples for the construction of stilling wells

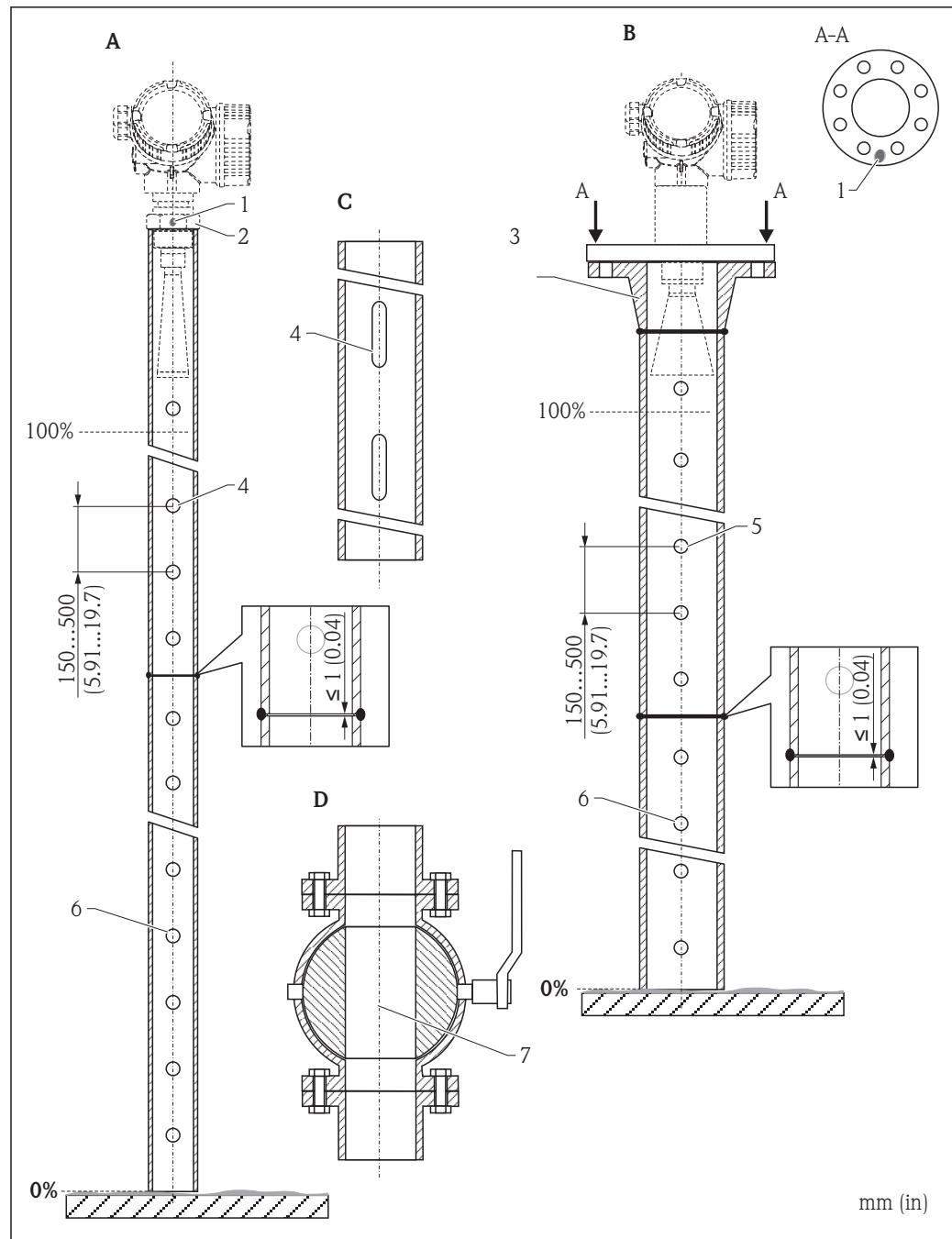

A0019009

- A Micropilot FMR50/FMR51: Horn 40mm(1½")
- B Micropilot FMR50/FMR51/FMR52/FMR54: Horn 80mm(3")
- C Stilling well with slots
- D Full bore ball valve
- 1 Marking for axial alignment
- 2 Threaded connection
- 3 e.g. welding neck flange DIN2633
- 4 ϕ hole max. 1/10 ϕ stilling well
- 5 ϕ hole max. 1/10 ϕ stilling well; single sided or drilled through
- 6 Inside of holes deburred
- 7 Diameter of opening of ball valve must always be equivalent to pipe diameter; avoid edges and constrictions.

Installation in bypass

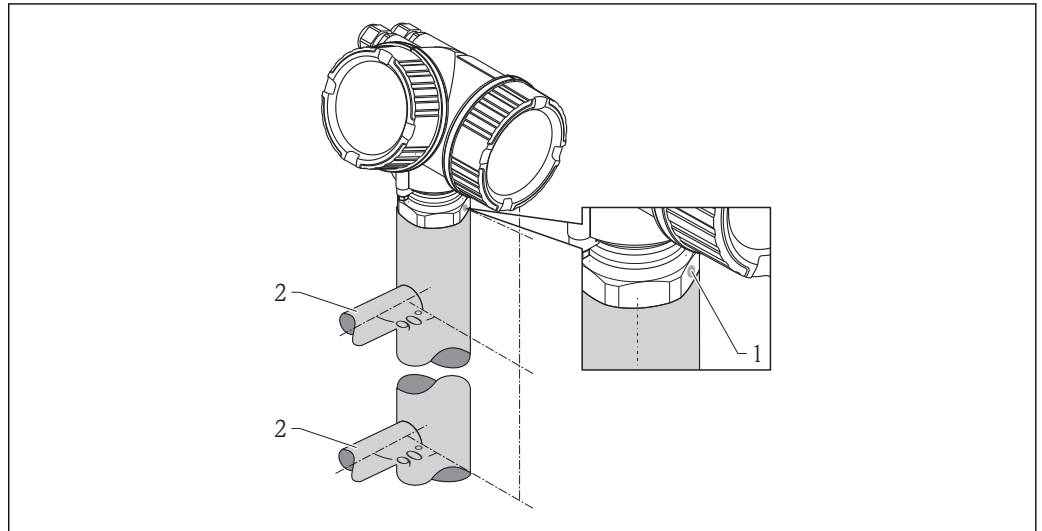

A0019446

16 Installation in bypass

- 1 Marking for antenna alignment
- 2 Tank connectors

- Align the marker perpendicular (90°) to the tank connectors.
- Measurements can be performed through an open full bore ball valve without any problems.
- After mounting, the housing can be turned 350° in order to simplify access to the display and the terminal compartment.

Recommendations for the bypass pipe

- Metal (no plastic or enamel coating).
- Constant diameter.
- Select horn antenna as big as possible. For intermediate sizes (e.g. 95 mm (3.5 in)) select next larger antenna and adapt it mechanically (for horn antennas).
- Diameter difference between horn antenna and inner diameter of the bypass as small as possible.
- At any transition (i.e. when using a ball valve or mending pipe segments), no gap may be created exceeding 1 mm (0.04 in).
- In the area of the tank connections (~ ±20 cm (7.87 in)) a reduced accuracy of the measurement has to be expected.

Example for the construction of a bypass

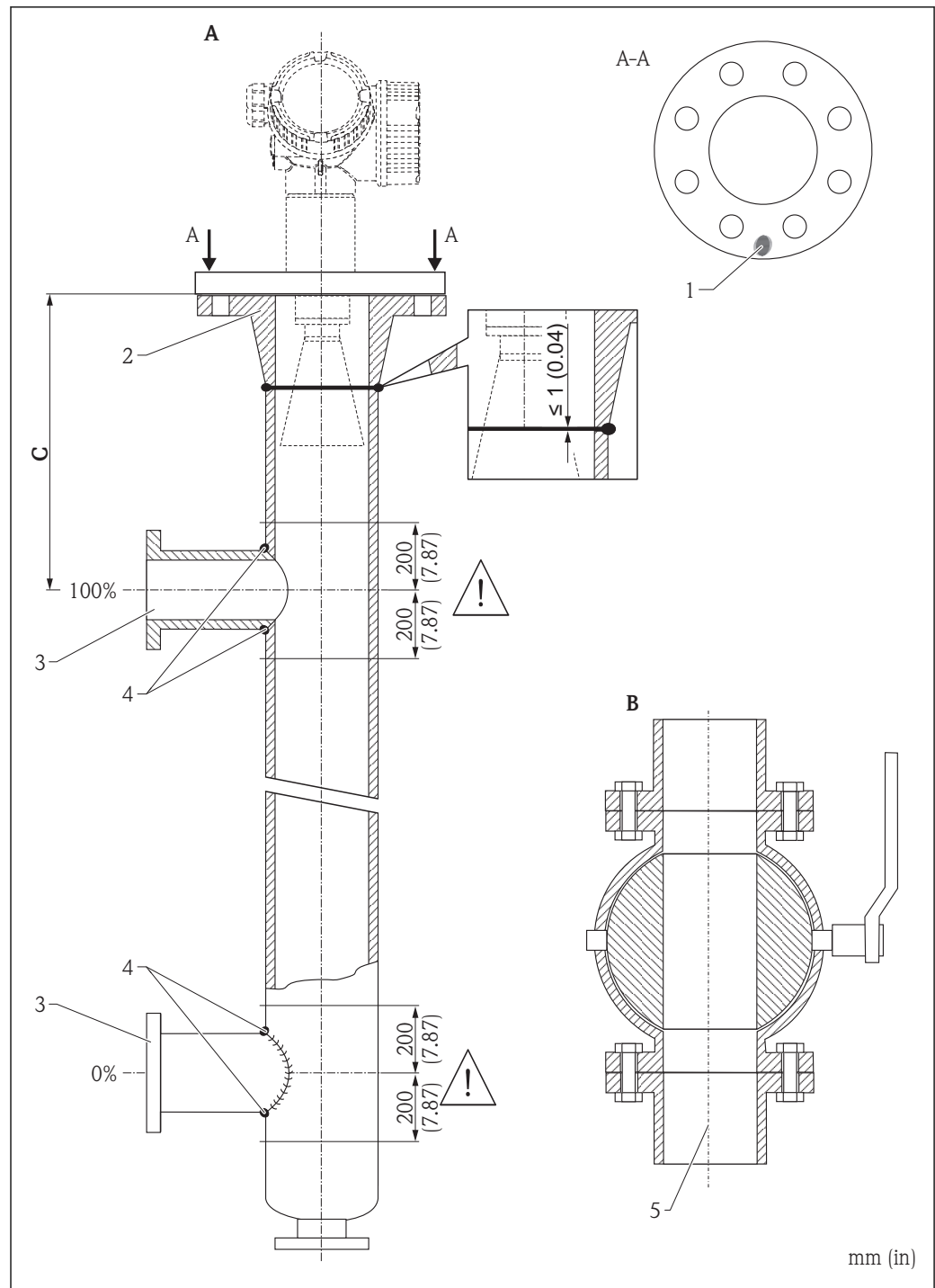

- A Micropilot FMR50/FMR51/FMR52/FMR54: Horn 80mm(3")
- B Full bore ball valve
- C Minimum distance to upper connection pipe: 400 mm (15,7 in)
- 1 Marking for axial alignment
- 2 e.g. welding neck flange DIN2633
- 3 Diameter of the connection pipes as small as possible
- 4 Do not weld through the pipe wall; the inside of the bypass must remain smooth.
- 5 Diameter of opening of ball valve must always be equivalent to pipe diameter. Avoid edges and constrictions.

Vessels with heat insulation

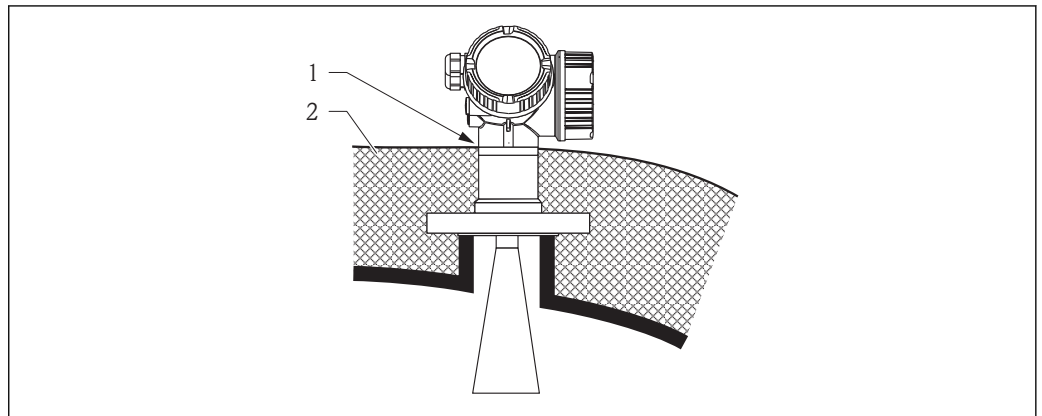

If process temperatures are high, the device must be included in normal tank insulation to prevent the electronics heating up as a result of heat radiation or convection. The insulation may not exceed beyond the neck of the housing.

Environment

Ambient temperature range

Measuring device	-40 to +80 °C (-40 to +176 °F); -50 °C (-58 °F) with manufacturer declaration on request
Local display	-20 to +70 °C (-4 to +158 °F), the readability of the display may be impaired at temperatures outside the temperature range.

When operating the device in the open with strong sunlight:

- Mount the device in a shady position.
- Avoid direct sunlight, especially in warmer regions.
- Use a weather protection cover (see accessories).

Ambient temperature limits

i The following diagrams take into account only functional aspects. There may be further restrictions for certified device versions. Please refer to the separate Safety Instructions → 103.

With a temperature (T_p) at the process connection the admissible ambient temperature (T_a) is reduced according to the following diagram (temperature derating):

Information concerning the derating tables

Option	Meaning
A	2-wire; 4-20 mA HART
B	2-wire; 4-20 mA HART, switch output
C	2-wire; 4-20 mA HART, 4-20 mA
E	2-wire; FF, switch output
G	2-wire; PA, switch output
K	4-wire 90-253VAC; 4-20 mA HART
L	4-wire 10, 4-48VDC; 4-20 mA HART

FMR51

Seal:

- Viton GLT, -40 to 150 °C (-40 to 302 °F)
- Kalrez, -20 to 150 °C (-4 to 302 °F)

Housing: GT18 (316 L)

Temperature unit: °C (°F)

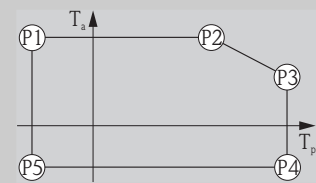

A0019351

Power Supply; Output (Pos. 2 of the product structure)	P1		P2		P3		P4		P5		P6	
	T_p	T_a	T_p	T_a	T_p	T_a	T_p	T_a	T_p	T_a	T_p	T_a
A	-40 (-40)	81 (178)	81 (178)	81 (178)	150 (302)	66 (151)	150 (302)	-40 (-40)	-40 (-40)	-40 (-40)	-	-
B Switch output not used	-40 (-40)	82 (180)	82 (180)	82 (180)	150 (302)	67 (153)	150 (302)	-40 (-40)	-40 (-40)	-40 (-40)	-	-
B Switch output used	-40 (-40)	77 (171)	77 (171)	77 (171)	150 (302)	61 (142)	150 (302)	-40 (-40)	-40 (-40)	-40 (-40)	-	-
C Channel 2 not used	-40 (-40)	82 (180)	82 (180)	82 (180)	150 (302)	67 (153)	150 (302)	-40 (-40)	-40 (-40)	-40 (-40)	-	-
C Channel 2 used	-40 (-40)	79 (174)	79 (174)	79 (174)	150 (302)	63 (145)	150 (302)	-40 (-40)	-40 (-40)	-40 (-40)	-	-
E, G Switch output not used	-40 (-40)	83 (181)	83 (181)	83 (181)	150 (302)	68 (154)	150 (302)	-40 (-40)	-40 (-40)	-40 (-40)	-	-

FMR51

Seal:

- Viton GLT, -40 to 150 °C (-40 to 302 °F)
- Kalrez, -20 to 150 °C (-4 to 302 °F)

Housing: GT18 (316 L)
Temperature unit: °C (°F)

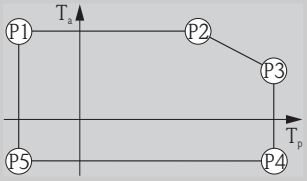

Power Supply; Output (Pos. 2 of the product structure)	P1		P2		P3		P4		P5		P6	
	T _p	T _a	T _p	T _a	T _p	T _a	T _p	T _a	T _p	T _a	T _p	T _a
E, G Switch output used	-40 (-40)	78 (172)	78 (172)	78 (172)	150 (302)	63 (145)	150 (302)	-40 (-40)	-40 (-40)	-40 (-40)	-	-
K, L	-40 (-40)	77 (171)	77 (171)	77 (171)	150 (302)	62 (144)	150 (302)	-40 (-40)	-40 (-40)	-40 (-40)	-	-

FMR51

Seal:

- Viton GLT, -40 to 150 °C (-40 to 302 °F)
- Kalrez, -20 to 150 °C (-4 to 302 °F)

Housing: GT19 (Plastics PBT)
Temperature unit: °C (°F)

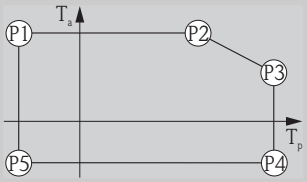

Power Supply; Output (Pos. 2 of the product structure)	P1		P2		P3		P4		P5		P6	
	T _p	T _a	T _p	T _a	T _p	T _a	T _p	T _a	T _p	T _a	T _p	T _a
A	-40 (-40)	80 (176)	80 (176)	80 (176)	150 (302)	56 (133)	150 (302)	-40 (-40)	-40 (-40)	-40 (-40)	-	-
B Switch output not used	-40 (-40)	76 (169)	76 (169)	76 (169)	150 (302)	56 (133)	150 (302)	-40 (-40)	-40 (-40)	-40 (-40)	-	-
B Switch output used	-40 (-40)	60 (140)	60 (140)	60 (140)	150 (302)	38 (100)	150 (302)	-40 (-40)	-40 (-40)	-40 (-40)	-	-
C Channel 2 not used	-40 (-40)	82 (180)	82 (180)	82 (180)	150 (302)	56 (133)	150 (302)	-40 (-40)	-40 (-40)	-40 (-40)	-	-
C Channel 2 used	-40 (-40)	74 (165)	74 (165)	74 (165)	150 (302)	55 (131)	150 (302)	-40 (-40)	-40 (-40)	-40 (-40)	-	-
E, G Switch output not used	-40 (-40)	79 (174)	79 (174)	79 (174)	150 (302)	56 (133)	150 (302)	-40 (-40)	-40 (-40)	-40 (-40)	-	-
E, G Switch output used	-40 (-40)	63 (145)	63 (145)	63 (145)	150 (302)	41 (106)	150 (302)	-40 (-40)	-40 (-40)	-40 (-40)	-	-

FMR51

Seal:

- Viton GLT, -40 to 150 °C (-40 to 302 °F)
- Kalrez, -20 to 150 °C (-4 to 302 °F)

Housing: GT20 (Alu, coated)
Temperature unit: °C (°F)

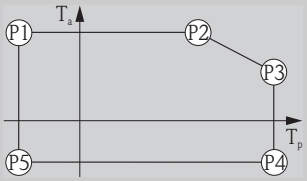

Power Supply; Output (Pos. 2 of the product structure)	P1		P2		P3		P4		P5		P6	
	T _p	T _a	T _p	T _a	T _p	T _a	T _p	T _a	T _p	T _a	T _p	T _a
A	-40 (-40)	81 (178)	81 (178)	81 (178)	150 (302)	69 (156)	150 (302)	-40 (-40)	-40 (-40)	-40 (-40)	-	-
B Switch output not used	-40 (-40)	82 (180)	82 (180)	82 (180)	150 (302)	70 (158)	150 (302)	-40 (-40)	-40 (-40)	-40 (-40)	-	-
B Switch output used	-40 (-40)	77 (171)	77 (171)	77 (171)	150 (302)	64 (147)	150 (302)	-40 (-40)	-40 (-40)	-40 (-40)	-	-

FMR51
Seal:
 ■ Viton GLT, -40 to 150 °C (-40 to 302 °F)
 ■ Kalrez, -20 to 150 °C (-4 to 302 °F)
Housing: GT20 (Alu, coated)
Temperature unit: °C (°F)

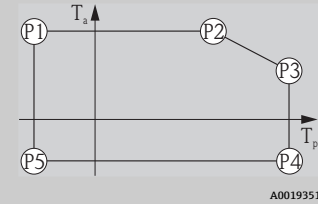

A0019351

Power Supply; Output (Pos. 2 of the product structure)	P1		P2		P3		P4		P5		P6	
	T _p	T _a	T _p	T _a	T _p	T _a	T _p	T _a	T _p	T _a	T _p	T _a
C Channel 2 not used	-40 (-40)	82 (180)	82 (180)	82 (180)	150 (302)	70 (158)	150 (302)	-40 (-40)	-40 (-40)	-40 (-40)	-	-
C Channel 2 used	-40 (-40)	79 (174)	79 (174)	79 (174)	150 (302)	66 (151)	150 (302)	-40 (-40)	-40 (-40)	-40 (-40)	-	-
E, G Switch output not used	-40 (-40)	83 (181)	83 (181)	83 (181)	150 (302)	71 (160)	150 (302)	-40 (-40)	-40 (-40)	-40 (-40)	-	-
E, G Switch output used	-40 (-40)	78 (172)	78 (172)	78 (172)	150 (302)	65 (149)	150 (302)	-40 (-40)	-40 (-40)	-40 (-40)	-	-
K, L	-40 (-40)	77 (171)	77 (171)	77 (171)	150 (302)	65 (149)	150 (302)	-40 (-40)	-40 (-40)	-40 (-40)	-	-

FMR51
Seal: Graphite, -40 to 250 °C (-40 to 482 °F)
Housing: GT18 (316 L)
Temperature unit: °C (°F)

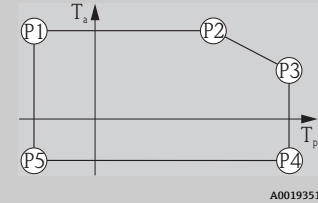

A0019351

Power Supply; Output (Pos. 2 of the product structure)	P1		P2		P3		P4		P5		P6	
	T _p	T _a	T _p	T _a	T _p	T _a	T _p	T _a	T _p	T _a	T _p	T _a
A	-40 (-40)	81 (178)	81 (178)	81 (178)	250 (482)	63 (145)	250 (482)	-40 (-40)	-40 (-40)	-40 (-40)	-	-
B Switch output not used	-40 (-40)	82 (180)	82 (180)	82 (180)	250 (482)	64 (147)	250 (482)	-40 (-40)	-40 (-40)	-40 (-40)	-	-
B Switch output used	-40 (-40)	77 (171)	77 (171)	77 (171)	250 (482)	58 (136)	250 (482)	-40 (-40)	-40 (-40)	-40 (-40)	-	-
C Channel 2 not used	-40 (-40)	82 (180)	82 (180)	82 (180)	250 (482)	64 (147)	250 (482)	-40 (-40)	-40 (-40)	-40 (-40)	-	-
C Channel 2 used	-40 (-40)	79 (174)	79 (174)	79 (174)	250 (482)	61 (142)	250 (482)	-40 (-40)	-40 (-40)	-40 (-40)	-	-
E, G Switch output not used	-40 (-40)	83 (181)	83 (181)	83 (181)	250 (482)	65 (149)	250 (482)	-40 (-40)	-40 (-40)	-40 (-40)	-	-
E, G Switch output used	-40 (-40)	78 (172)	78 (172)	78 (172)	250 (482)	60 (140)	250 (482)	-40 (-40)	-40 (-40)	-40 (-40)	-	-
K, L	-40 (-40)	77 (171)	77 (171)	77 (171)	250 (482)	59 (138)	250 (482)	-40 (-40)	-40 (-40)	-40 (-40)	-	-

FMR51
 Seal: Graphite, -40 to 250 °C (-40 to 482 °F)
 Housing: GT19 (Plastics PBT)
 Temperature unit: °C (°F)

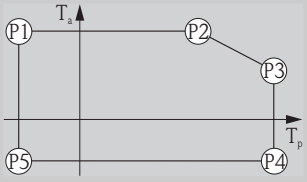

Power Supply; Output (Pos. 2 of the product structure)	P1		P2		P3		P4		P5		P6	
	T _p	T _a	T _p	T _a	T _p	T _a	T _p	T _a	T _p	T _a	T _p	T _a
A	-40 (-40)	80 (176)	80 (176)	80 (176)	250 (482)	44 (111)	250 (482)	-40 (-40)	-40 (-40)	-40 (-40)	-	-
B Switch output not used	-40 (-40)	76 (169)	76 (169)	76 (169)	250 (482)	44 (111)	250 (482)	-40 (-40)	-40 (-40)	-40 (-40)	-	-
B Switch output used	-40 (-40)	60 (140)	60 (140)	60 (140)	250 (482)	32 (90)	250 (482)	-40 (-40)	-40 (-40)	-40 (-40)	-	-
C Channel 2 not used	-40 (-40)	82 (180)	82 (180)	82 (180)	250 (482)	44 (111)	250 (482)	-40 (-40)	-40 (-40)	-40 (-40)	-	-
C Channel 2 used	-40 (-40)	74 (165)	74 (165)	74 (165)	250 (482)	44 (111)	250 (482)	-40 (-40)	-40 (-40)	-40 (-40)	-	-
E, G Switch output not used	-40 (-40)	79 (174)	79 (174)	79 (174)	250 (482)	44 (111)	250 (482)	-40 (-40)	-40 (-40)	-40 (-40)	-	-
E, G Switch output used	-40 (-40)	63 (145)	63 (145)	63 (145)	250 (482)	35 (95)	250 (482)	-40 (-40)	-40 (-40)	-40 (-40)	-	-

FMR51
 Seal: Graphite, -40 to 250 °C (-40 to 482 °F)
 Housing: GT20 (Alu, coated)
 Temperature unit: °C (°F)

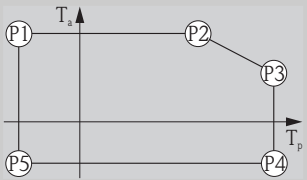

Power Supply; Output (Pos. 2 of the product structure)	P1		P2		P3		P4		P5		P6	
	T _p	T _a	T _p	T _a	T _p	T _a	T _p	T _a	T _p	T _a	T _p	T _a
A	-40 (-40)	81 (178)	81 (178)	81 (178)	250 (482)	67 (153)	250 (482)	-40 (-40)	-40 (-40)	-40 (-40)	-	-
B Switch output not used	-40 (-40)	82 (180)	82 (180)	82 (180)	250 (482)	68 (154)	250 (482)	-40 (-40)	-40 (-40)	-40 (-40)	-	-
B Switch output used	-40 (-40)	77 (171)	77 (171)	77 (171)	250 (482)	62 (144)	250 (482)	-40 (-40)	-40 (-40)	-40 (-40)	-	-
C Channel 2 not used	-40 (-40)	82 (180)	82 (180)	82 (180)	250 (482)	68 (154)	250 (482)	-40 (-40)	-40 (-40)	-40 (-40)	-	-
C Channel 2 used	-40 (-40)	79 (174)	79 (174)	79 (174)	250 (482)	64 (147)	250 (482)	-40 (-40)	-40 (-40)	-40 (-40)	-	-
E, G Switch output not used	-40 (-40)	83 (181)	83 (181)	83 (181)	250 (482)	69 (156)	250 (482)	-40 (-40)	-40 (-40)	-40 (-40)	-	-
E, G Switch output used	-40 (-40)	78 (172)	78 (172)	78 (172)	250 (482)	64 (147)	250 (482)	-40 (-40)	-40 (-40)	-40 (-40)	-	-
K, L	-40 (-40)	77 (171)	77 (171)	77 (171)	250 (482)	63 (154)	250 (482)	-40 (-40)	-40 (-40)	-40 (-40)	-	-

FMR51
 Seal: Graphite, -196 to 450 °C (-321 to 842 °F)
 Housing: GT18 (316 L)
 Temperature unit: °C (°F)

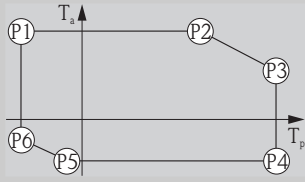

Power Supply; Output (Pos. 2 of the product structure)	P1		P2		P3		P4		P5		P6	
	T _p	T _a	T _p	T _a	T _p	T _a	T _p	T _a	T _p	T _a	T _p	T _a
A	-196 (-321)	81 (178)	81 (178)	81 (178)	450 (842)	26 (79)	450 (842)	-40 (-40)	-40 (-40)	-40 (-40)	-196 (-321)	-15 (+5)
B Switch output not used	-196 (-321)	82 (180)	82 (180)	82 (180)	450 (842)	26 (79)	450 (842)	-40 (-40)	-40 (-40)	-40 (-40)	-196 (-321)	-15 (+5)
B Switch output used	-196 (-321)	77 (171)	77 (171)	77 (171)	450 (842)	25 (77)	450 (842)	-40 (-40)	-40 (-40)	-40 (-40)	-196 (-321)	-15 (+5)
C Channel 2 not used	-196 (-321)	82 (180)	82 (180)	82 (180)	450 (842)	26 (79)	450 (842)	-40 (-40)	-40 (-40)	-40 (-40)	-196 (-321)	-15 (+5)
C Channel 2 used	-196 (-321)	79 (174)	79 (174)	79 (174)	450 (842)	26 (79)	450 (842)	-40 (-40)	-40 (-40)	-40 (-40)	-196 (-321)	-15 (+5)
E, G Switch output not used	-196 (-321)	83 (181)	83 (181)	83 (181)	450 (842)	26 (79)	450 (842)	-40 (-40)	-40 (-40)	-40 (-40)	-196 (-321)	-15 (+5)
E, G Switch output used	-196 (-321)	78 (172)	78 (172)	78 (172)	450 (842)	26 (79)	450 (842)	-40 (-40)	-40 (-40)	-40 (-40)	-196 (-321)	-15 (+5)
K, L	-196 (-321)	77 (171)	77 (171)	77 (171)	450 (842)	26 (79)	450 (842)	-40 (-40)	-40 (-40)	-40 (-40)	-196 (-321)	-15 (+5)

FMR51
 Seal: Graphite, -196 to 450 °C (-321 to 842 °F)
 Housing: GT19 (Plastics PBT)
 Temperature unit: °C (°F)

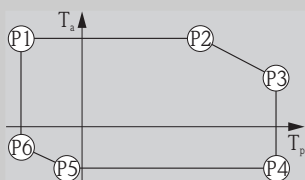

Power Supply; Output (Pos. 2 of the product structure)	P1		P2		P3		P4		P5		P6	
	T _p	T _a	T _p	T _a	T _p	T _a	T _p	T _a	T _p	T _a	T _p	T _a
A	-196 (-321)	80 (176)	80 (176)	80 (176)	450 (842)	-29 (-20)	450 (842)	-40 (-40)	-40 (-40)	-40 (-40)	-196 (-321)	9 (48)
B Switch output not used	-196 (-321)	76 (169)	76 (169)	76 (169)	450 (842)	-29 (-20)	450 (842)	-40 (-40)	-40 (-40)	-40 (-40)	-196 (-321)	9 (48)
B Switch output used	-196 (-321)	60 (140)	60 (140)	60 (140)	450 (842)	-29 (-20)	450 (842)	-40 (-40)	-40 (-40)	-40 (-40)	-196 (-321)	9 (48)
C Channel 2 not used	-196 (-321)	82 (180)	82 (180)	82 (180)	450 (842)	-29 (-20)	450 (842)	-40 (-40)	-40 (-40)	-40 (-40)	-196 (-321)	9 (48)
C Channel 2 used	-196 (-321)	74 (165)	74 (165)	74 (165)	450 (842)	-29 (-20)	450 (842)	-40 (-40)	-40 (-40)	-40 (-40)	-196 (-321)	9 (48)
E, G Switch output not used	-196 (-321)	79 (174)	79 (174)	79 (174)	450 (842)	-29 (-20)	450 (842)	-40 (-40)	-40 (-40)	-40 (-40)	-196 (-321)	9 (48)
E, G Switch output used	-196 (-321)	63 (145)	63 (145)	63 (145)	450 (842)	-29 (-20)	450 (842)	-40 (-40)	-40 (-40)	-40 (-40)	-196 (-321)	9 (48)

FMR51
 Seal: Graphite, -196 to 450 °C (-321 to 842 °F)
 Housing: GT20 (Alu, coated)
 Temperature unit: °C (°F)

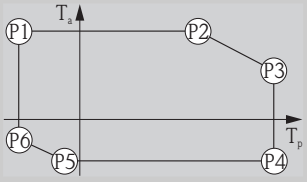

Power Supply; Output (Pos. 2 of the product structure)	P1		P2		P3		P4		P5		P6	
	T _p	T _a	T _p	T _a	T _p	T _a	T _p	T _a	T _p	T _a	T _p	T _a
A	-196 (-321)	81 (178)	81 (178)	81 (178)	450 (842)	39 (102)	450 (842)	-40 (-40)	-40 (-40)	-40 (-40)	-196 (-321)	-20 (-4)
B Switch output not used	-196 (-321)	82 (180)	82 (180)	82 (180)	450 (842)	39 (102)	450 (842)	-40 (-40)	-40 (-40)	-40 (-40)	-196 (-321)	-20 (-4)
B Switch output used	-196 (-321)	77 (171)	77 (171)	77 (171)	450 (842)	36 (97)	450 (842)	-40 (-40)	-40 (-40)	-40 (-40)	-196 (-321)	-20 (-4)
C Channel 2 not used	-196 (-321)	82 (180)	82 (180)	82 (180)	450 (842)	39 (102)	450 (842)	-40 (-40)	-40 (-40)	-40 (-40)	-196 (-321)	-20 (-4)
C Channel 2 used	-196 (-321)	79 (174)	79 (174)	79 (174)	450 (842)	38 (100)	450 (842)	-40 (-40)	-40 (-40)	-40 (-40)	-196 (-321)	-20 (-4)
E, G Switch output not used	-196 (-321)	83 (181)	83 (181)	83 (181)	450 (842)	39 (102)	450 (842)	-40 (-40)	-40 (-40)	-40 (-40)	-196 (-321)	-20 (-4)
E, G Switch output used	-196 (-321)	78 (172)	78 (172)	78 (172)	450 (842)	38 (100)	450 (842)	-40 (-40)	-40 (-40)	-40 (-40)	-196 (-321)	-20 (-4)
K, L	-196 (-321)	77 (171)	77 (171)	77 (171)	450 (842)	37 (99)	450 (842)	-40 (-40)	-40 (-40)	-40 (-40)	-196 (-321)	-20 (-4)

FMR52
 Antenna: Horn 50mm/2"
 Housing: GT18 (316 L)
 Temperature unit: °C (°F)

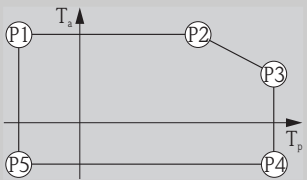

Power Supply; Output (Pos. 2 of the product structure)	P1		P2		P3		P4		P5		P6	
	T _p	T _a	T _p	T _a	T _p	T _a	T _p	T _a	T _p	T _a	T _p	T _a
A	-40 (-40)	81 (178)	81 (178)	81 (178)	200 (392)	61 (142)	200 (392)	-40 (-40)	-40 (-40)	-40 (-40)	-	-
B Switch output not used	-40 (-40)	82 (180)	82 (180)	82 (180)	200 (392)	61 (142)	200 (392)	-40 (-40)	-40 (-40)	-40 (-40)	-	-
B Switch output used	-40 (-40)	77 (171)	77 (171)	77 (171)	200 (392)	55 (131)	200 (392)	-40 (-40)	-40 (-40)	-40 (-40)	-	-
C Channel 2 not used	-40 (-40)	82 (180)	82 (180)	82 (180)	200 (392)	62 (144)	200 (392)	-40 (-40)	-40 (-40)	-40 (-40)	-	-
C Channel 2 used	-40 (-40)	79 (174)	79 (174)	79 (174)	200 (392)	58 (136)	200 (392)	-40 (-40)	-40 (-40)	-40 (-40)	-	-
E, G Switch output not used	-40 (-40)	83 (181)	83 (181)	83 (181)	200 (392)	62 (144)	200 (392)	-40 (-40)	-40 (-40)	-40 (-40)	-	-
E, G Switch output used	-40 (-40)	78 (172)	78 (172)	78 (172)	200 (392)	57 (135)	200 (392)	-40 (-40)	-40 (-40)	-40 (-40)	-	-
K, L	-40 (-40)	77 (171)	77 (171)	77 (171)	200 (392)	56 (133)	200 (392)	-40 (-40)	-40 (-40)	-40 (-40)	-	-

FMR52
Antenna: Horn 50mm/2"
Housing: GT19 (Plastics PBT)
Temperature unit: °C (°F)

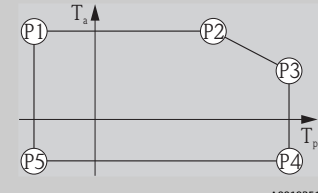

A0019351

Power Supply; Output (Pos. 2 of the product structure)	P1		P2		P3		P4		P5		P6	
	T _p	T _a	T _p	T _a	T _p	T _a	T _p	T _a	T _p	T _a	T _p	T _a
A	-40 (-40)	80 (176)	80 (176)	80 (176)	200 (392)	42 (108)	200 (392)	-40 (-40)	-40 (-40)	-40 (-40)	-	-
B Switch output not used	-40 (-40)	76 (169)	76 (169)	76 (169)	200 (392)	42 (108)	200 (392)	-40 (-40)	-40 (-40)	-40 (-40)	-	-
B Switch output used	-40 (-40)	60 (140)	60 (140)	60 (140)	200 (392)	31 (88)	200 (392)	-40 (-40)	-40 (-40)	-40 (-40)	-	-
C Channel 2 not used	-40 (-40)	82 (180)	82 (180)	82 (180)	200 (392)	42 (108)	200 (392)	-40 (-40)	-40 (-40)	-40 (-40)	-	-
C Channel 2 used	-40 (-40)	74 (165)	74 (165)	74 (165)	200 (392)	42 (108)	200 (392)	-40 (-40)	-40 (-40)	-40 (-40)	-	-
E, G Switch output not used	-40 (-40)	79 (174)	79 (174)	79 (174)	200 (392)	42 (108)	200 (392)	-40 (-40)	-40 (-40)	-40 (-40)	-	-
E, G Switch output used	-40 (-40)	63 (145)	63 (145)	63 (145)	200 (392)	33 (91)	200 (392)	-40 (-40)	-40 (-40)	-40 (-40)	-	-

FMR52
Antenna: Horn 50mm/2"
Housing: GT20 (Alu, coated)
Temperature unit: °C (°F)

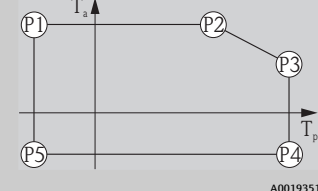

A0019351

Power Supply; Output (Pos. 2 of the product structure)	P1		P2		P3		P4		P5		P6	
	T _p	T _a	T _p	T _a	T _p	T _a	T _p	T _a	T _p	T _a	T _p	T _a
A	-40 (-40)	81 (178)	81 (178)	81 (178)	200 (392)	65 (149)	200 (392)	-40 (-40)	-40 (-40)	-40 (-40)	-	-
B Switch output not used	-40 (-40)	82 (180)	82 (180)	82 (180)	200 (392)	65 (149)	200 (392)	-40 (-40)	-40 (-40)	-40 (-40)	-	-
B Switch output used	-40 (-40)	77 (171)	77 (171)	77 (171)	200 (392)	59 (138)	200 (392)	-40 (-40)	-40 (-40)	-40 (-40)	-	-
C Channel 2 not used	-40 (-40)	82 (180)	82 (180)	82 (180)	200 (392)	66 (151)	200 (392)	-40 (-40)	-40 (-40)	-40 (-40)	-	-
C Channel 2 used	-40 (-40)	79 (174)	79 (174)	79 (174)	200 (392)	62 (144)	200 (392)	-40 (-40)	-40 (-40)	-40 (-40)	-	-
E, G Switch output not used	-40 (-40)	83 (181)	83 (181)	83 (181)	200 (392)	66 (151)	200 (392)	-40 (-40)	-40 (-40)	-40 (-40)	-	-
E, G Switch output used	-40 (-40)	78 (172)	78 (172)	78 (172)	200 (392)	61 (142)	200 (392)	-40 (-40)	-40 (-40)	-40 (-40)	-	-
K, L	-40 (-40)	77 (171)	77 (171)	77 (171)	200 (392)	60 (140)	200 (392)	-40 (-40)	-40 (-40)	-40 (-40)	-	-

FMR52
Antenna: Horn 80mm/2"
Housing: GT18 (316 L)
Temperature unit: °C (°F)

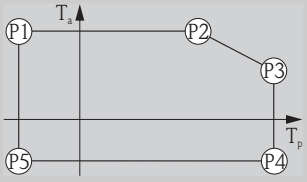

Power Supply; Output (Pos. 2 of the product structure)	P1		P2		P3		P4		P5		P6	
	T _p	T _a	T _p	T _a	T _p	T _a	T _p	T _a	T _p	T _a	T _p	T _a
A	-40 (-40)	81 (178)	81 (178)	81 (178)	200 (392)	57 (135)	200 (392)	-40 (-40)	-40 (-40)	-40 (-40)	-	-
B Switch output not used	-40 (-40)	82 (180)	82 (180)	82 (180)	200 (392)	57 (135)	200 (392)	-40 (-40)	-40 (-40)	-40 (-40)	-	-
B Switch output used	-40 (-40)	77 (171)	77 (171)	77 (171)	200 (392)	51 (124)	200 (392)	-40 (-40)	-40 (-40)	-40 (-40)	-	-
C Channel 2 not used	-40 (-40)	82 (180)	82 (180)	82 (180)	200 (392)	57 (135)	200 (392)	-40 (-40)	-40 (-40)	-40 (-40)	-	-
C Channel 2 used	-40 (-40)	79 (174)	79 (174)	79 (174)	200 (392)	54 (129)	200 (392)	-40 (-40)	-40 (-40)	-40 (-40)	-	-
E, G Switch output not used	-40 (-40)	83 (181)	83 (181)	83 (181)	200 (392)	57 (135)	200 (392)	-40 (-40)	-40 (-40)	-40 (-40)	-	-
E, G Switch output used	-40 (-40)	78 (172)	78 (172)	78 (172)	200 (392)	53 (127)	200 (392)	-40 (-40)	-40 (-40)	-40 (-40)	-	-
K, L	-40 (-40)	77 (171)	77 (171)	77 (171)	200 (392)	52 (126)	200 (392)	-40 (-40)	-40 (-40)	-40 (-40)	-	-

FMR52
Antenna: Horn 80mm/2"
Housing: GT19 (Plastics PBT)
Temperature unit: °C (°F)

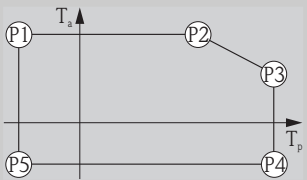

Power Supply; Output (Pos. 2 of the product structure)	P1		P2		P3		P4		P5		P6	
	T _p	T _a	T _p	T _a	T _p	T _a	T _p	T _a	T _p	T _a	T _p	T _a
A	-40 (-40)	80 (176)	80 (176)	80 (176)	200 (392)	36 (97)	200 (392)	-40 (-40)	-40 (-40)	-40 (-40)	-	-
B Switch output not used	-40 (-40)	76 (169)	76 (169)	76 (169)	200 (392)	36 (97)	200 (392)	-40 (-40)	-40 (-40)	-40 (-40)	-	-
B Switch output used	-40 (-40)	60 (140)	60 (140)	60 (140)	200 (392)	27 (81)	200 (392)	-40 (-40)	-40 (-40)	-40 (-40)	-	-
C Channel 2 not used	-40 (-40)	82 (180)	82 (180)	82 (180)	200 (392)	36 (97)	200 (392)	-40 (-40)	-40 (-40)	-40 (-40)	-	-
C Channel 2 used	-40 (-40)	74 (165)	74 (165)	74 (165)	200 (392)	36 (97)	200 (392)	-40 (-40)	-40 (-40)	-40 (-40)	-	-
E, G Switch output not used	-40 (-40)	79 (174)	79 (174)	79 (174)	200 (392)	36 (97)	200 (392)	-40 (-40)	-40 (-40)	-40 (-40)	-	-
E, G Switch output used	-40 (-40)	63 (145)	63 (145)	63 (145)	200 (392)	30 (86)	200 (392)	-40 (-40)	-40 (-40)	-40 (-40)	-	-

FMR52 Antenna: Horn 80mm/2" Housing: GT20 (Alu, coated) Temperature unit: °C (°F)												
Power Supply; Output (Pos. 2 of the product structure)	P1		P2		P3		P4		P5		P6	
	T _p	T _a	T _p	T _a	T _p	T _a	T _p	T _a	T _p	T _a	T _p	T _a
A	-40 (-40)	81 (178)	81 (178)	81 (178)	200 (392)	61 (142)	200 (392)	-40 (-40)	-40 (-40)	-40 (-40)	-	-
B Switch output not used	-40 (-40)	82 (180)	82 (180)	82 (180)	200 (392)	62 (144)	200 (392)	-40 (-40)	-40 (-40)	-40 (-40)	-	-
B Switch output used	-40 (-40)	77 (171)	77 (171)	77 (171)	200 (392)	56 (133)	200 (392)	-40 (-40)	-40 (-40)	-40 (-40)	-	-
C Channel 2 not used	-40 (-40)	82 (180)	82 (180)	82 (180)	200 (392)	62 (144)	200 (392)	-40 (-40)	-40 (-40)	-40 (-40)	-	-
C Channel 2 used	-40 (-40)	79 (174)	79 (174)	79 (174)	200 (392)	58 (136)	200 (392)	-40 (-40)	-40 (-40)	-40 (-40)	-	-
E, G Switch output not used	-40 (-40)	83 (181)	83 (181)	83 (181)	200 (392)	62 (144)	200 (392)	-40 (-40)	-40 (-40)	-40 (-40)	-	-
E, G Switch output used	-40 (-40)	78 (172)	78 (172)	78 (172)	200 (392)	58 (136)	200 (392)	-40 (-40)	-40 (-40)	-40 (-40)	-	-
K, L	-40 (-40)	77 (171)	77 (171)	77 (171)	200 (392)	57 (135)	200 (392)	-40 (-40)	-40 (-40)	-40 (-40)	-	-

Storage temperature -40 to +80 °C (-40 to +176 °F)
-50 °C (-58 °F) with manufacturer declaration on request

Climate class DIN EN 60068-2-38 (test Z/AD)

Altitude according to IEC61010-1 Ed.3 Up to 2 000 m (6 600 ft) above MSL.

Degree of protection

- With closed housing tested according to:
 - IP68, NEMA6P (24 h at 1.83 m under water surface) ⁷⁾
 - For plastic housing with transparent cover (display module): IP68 (24 h at 1.00 m under water surface) ⁸⁾
 - IP66, NEMA4X
- With open housing: IP20, NEMA1
- Display module: IP22, NEMA2

 Degree of protection IP68 NEMA6P applies for M12 PROFIBUS PA plugs only when the PROFIBUS cable is plugged in and is also rated IP68 NEMA6P.

Vibration resistance DIN EN 60068-2-64 / IEC 60068-2-64: 20 to 2 000 Hz, 1 (m/s²)²/Hz

Cleaning the antenna The antenna can get contaminated, depending on the application. The emission and reception of microwaves can thus eventually be hindered. The degree of contamination leading to an error depends on the medium and the reflectivity, mainly determined by the dielectric constant ϵ_r .

If the medium tends to cause contamination and deposits, cleaning on a regular basis is recommended. Care has to be taken not to damage the antenna in the process of a mechanical or hose-down cleaning. The material compatibility has to be considered if cleaning agents are used! The maximum permitted temperature at the flange should not be exceeded.

7) also valid for the "Sensor remote" version

8) This restriction is valid if the following options of the product structure have been selected at the same time: 030("Display, Operation") = C("SD02") or E("SD03"); 040("Housing") = A("GT19").

Electromagnetic compatibility (EMC)

Electromagnetic compatibility to all relevant requirements of the EN 61326- series and NAMUR recommendation EMC (NE21). For details see declaration of conformity.⁹⁾

If only the analogue signal is used, unshielded interconnection lines are sufficient for the installation. In case of using the digital signal (HART/ PA/ FF) use shielded interconnection lines.

Max. fluctuations during EMC- tests: < 0.5 % of the span. As an exception to this, the maximum fluctuations may amount to 2 % of the span for devices with plastic housing and see-through lid (integrated display SD02 or SD03) if strong electromagnetic interferences in the frequency range of 1 to 2 GHz are present.

9) Can be downloaded from www.endress.com.

Process

Process temperature, Process pressure

i The specified pressure range may be reduced due to the selected process connection. The pressure rating (PN) specified on the flanges refers to a reference temperature of 20 °C, for ASME flanges 100 °F. Pay attention to pressure-temperature dependencies.

Please refer to the following standards for the pressure values permitted for higher temperatures:

- EN 1092-1: 2001 Tab. 18

With regard to their temperature stability properties, the materials 1.4435 and 1.4404 are grouped under 13E0 in EN 1092-1 Tab. 18. The chemical composition of the two materials can be identical.

- ASME B 16.5a - 1998 Tab. 2-2.2 F316
- ASME B 16.5a - 1998 Tab. 2.3.8 N10276
- JIS B 2220

FMR51

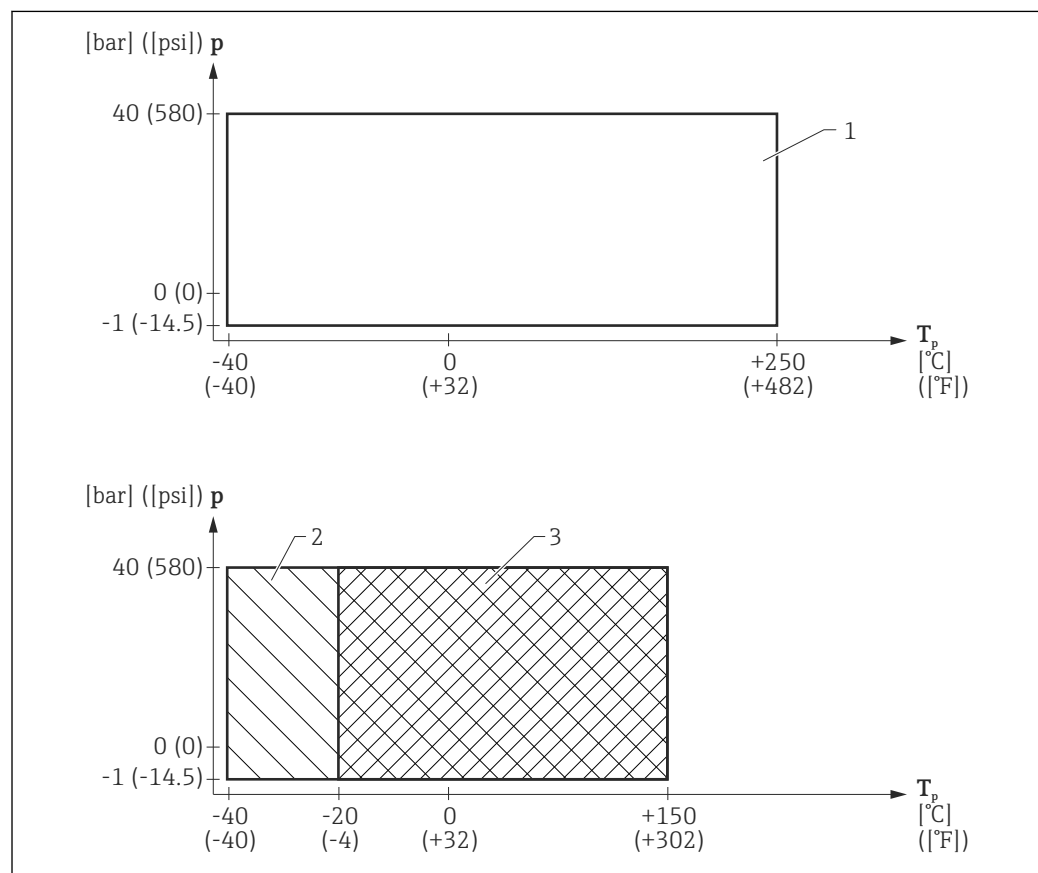

A0022656-EN

17 FMR51: Admissible range of process temperature and process pressure

- 1 Seal: Graphite (Feature 090 "Seal", Option D3)
- 2 Seal: Viton (Feature 090 "Seal", Option A5)
- 3 Seal: Kalrez (Feature 090 "Seal", Option C1)

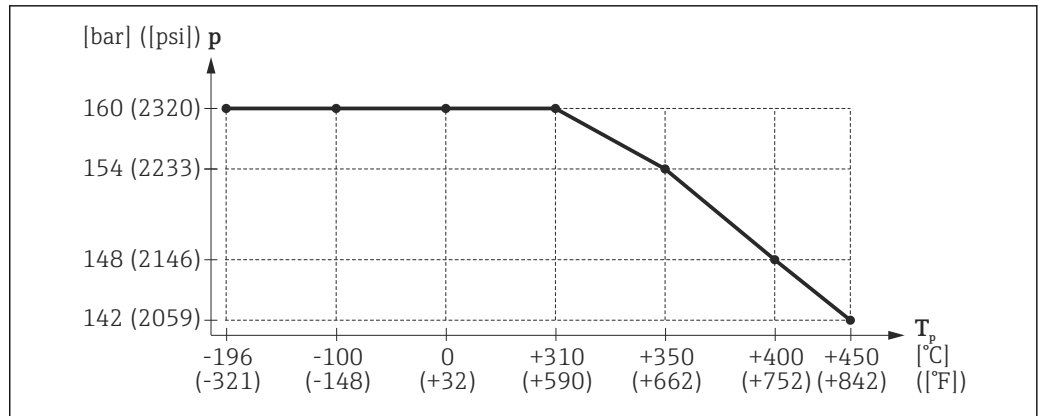

A0020555-EN

18 FMR51: Admissible range of process temperature and process pressure of the HT version (Feature 090 "Seal", Option D2)

Feature 090 "Seal"	Admissible process temperature	Admissible process pressure
A5: Viton GLT	-40 to +150 °C (-40 to 302 °F)	$p_{rel} = -1$ to 40 bar (-14.5 to 580 psi)
C1: Kalrez	-20 to +150 °C (-4 to 302 °F)	
D3: Graphite, 40...250°C/-40...482°F	-40 to +250 °C (-40 to 482 °F)	
D2: Graphite, 196...450°C/-321...842°F (HT)	-196 to +450 °C (-321 to 842 °F)	$p_{rel} = -1$ to 160 bar (-14.5 to 2 320 psi) Observe the temperature-dependent restrictions indicated in the diagram above ¹⁾ .

1) For devices with CRN approval the pressure range may be reduced → 89

FMR52

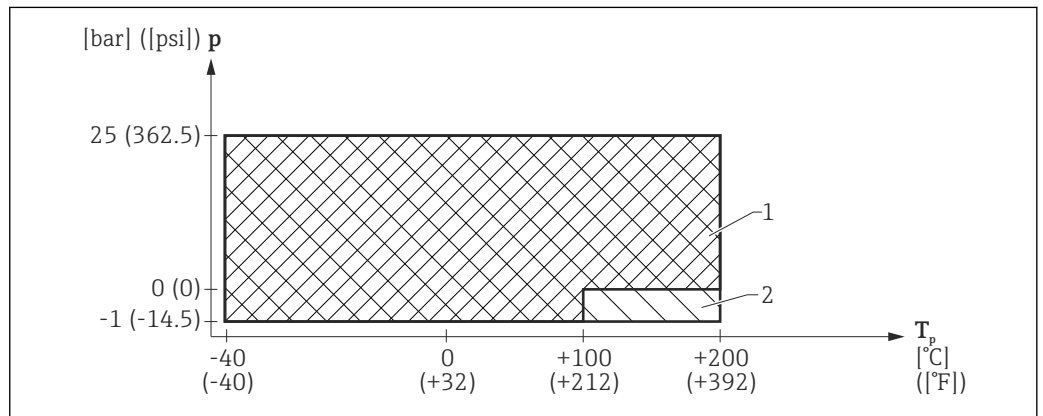

A0023250-EN

19 FMR52: Admissible range of process temperature and process pressure

- 1 Valid for the following process connections: 6" (ANSI), DN150 (EN), 10K150A (JIS)
- 2 Valid for all other types of process connection

Feature 100 "Process Connection"	Admissible process temperature	Admissible process pressure
<ul style="list-style-type: none"> ▪ AFK: 2" 150lbs (ANSI) ▪ AGK: 3" 150lbs (ANSI) ▪ AHK: 4" 150lbs (ANSI) ▪ CFK: DN50 PN10/16 (EN) ▪ CGK: DN80 PN10/16 (EN) ▪ CHK: DN100 PN10/16 (EN) ▪ KFK: 10K 50A (JIS) ▪ KGK: 10K 80A (JIS) ▪ KHK: 10K 100A (JIS) ▪ MRK: DIN11851 DN50 ▪ MTK: DIN11851 DN80 ▪ TDK: Tri-Clamp 2" ▪ TFK: Tri-Clamp 3" ▪ THK: Tri-Clamp 4" 	-40 to +200 °C (-40 to 392 °F)	$p_{rel} = -1 \text{ to } 25 \text{ bar } (-14.5 \text{ to } 363 \text{ psi})$ ¹⁾
<ul style="list-style-type: none"> ▪ AJK: 6" 150lbs (ANSI) ▪ CJK: DN150 PN10/16 (EN) ▪ KJK: 10K 150A (JIS) 		<ul style="list-style-type: none"> ▪ For T = -40 to +100 °C (-40 to 212 °F): $p_{rel} = -1 \text{ to } 25 \text{ bar } (-14.5 \text{ to } 363 \text{ psi})$¹⁾ ▪ For T = 100 to 200 °C (212 to 392 °F): $p_{rel} = 0 \text{ to } 25 \text{ bar } (0 \text{ to } 363 \text{ psi})$¹⁾

1) For devices with CRN approval the pressure range may be reduced →  89

Dielectric constant

- **For liquids**
 - $\epsilon_r \geq 1.9$ in free-field applications
 - $\epsilon_r \geq 1.4$ in stilling well
- **For bulk solids**
 $\epsilon_r \geq 1.6$

-  For dielectric constants (DC values) of many media commonly used in various industries refer to:
- the Endress+Hauser DC manual (CP01076F)
 - the Endress+Hauser "DC Values App" (available for Android and iOS)

Mechanical construction

Dimensions

Dimensions of the electronics housing

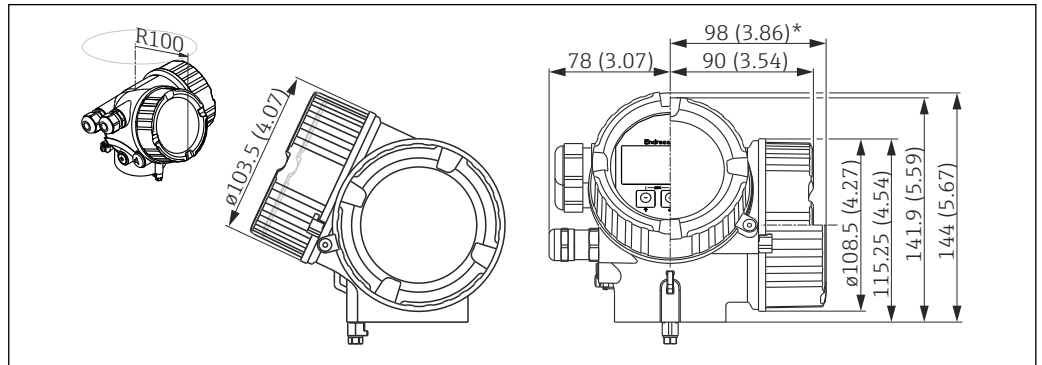

A0011666

20 Housing GT18 (316L); Dimensions in mm (in)

*for devices with integrated overvoltage protection.

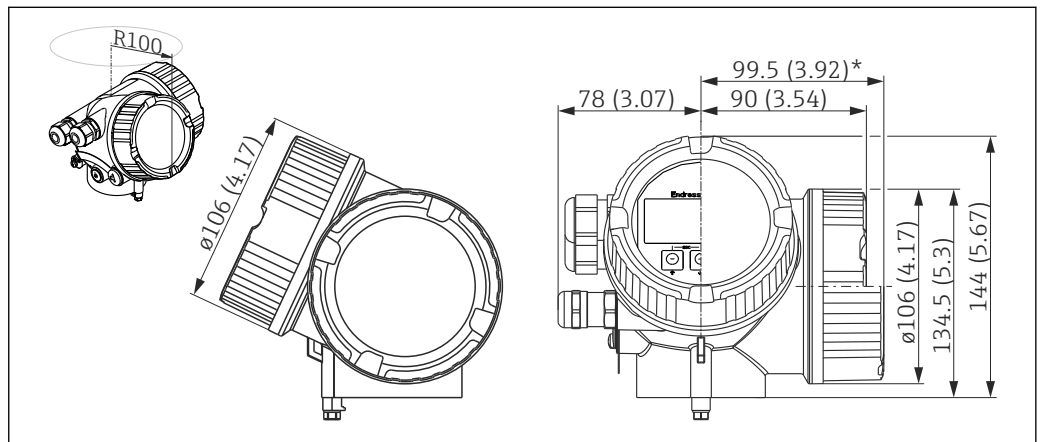

A0011346

21 Housing GT19 (Plastics PBT); Dimensions in mm (in)

*for devices with integrated overvoltage protection.

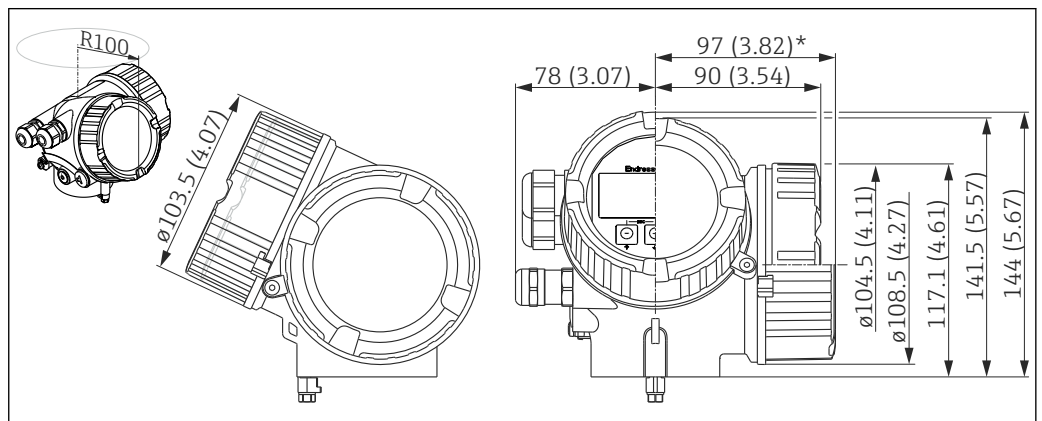

A0020751

22 Housing GT20 (Alu coated); Dimensions in mm (in)

*for devices with integrated overvoltage protection.

FMR51: Version T ≤ 150 °C (302 °F); without antenna extension

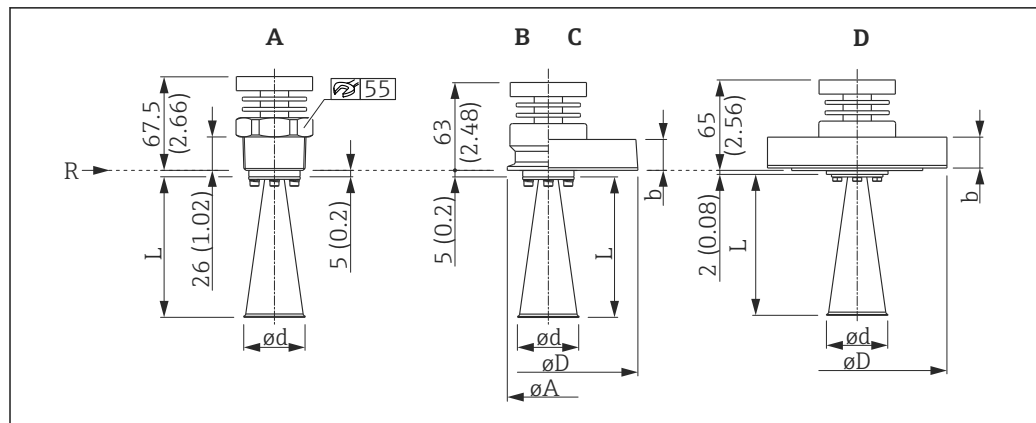

A0023383

23 FMR51: Version T < 150 °C (302 °F); without antenna extension; dimensions: mm (in)

- A Process connection: Thread
 B Process connection: Tri-Clamp ISO2852
 C Process connection: Flange 316L
 D Process connection: Flange AlloyC>316L
 R Reference point of the measurement

Valid for the following device versions

Feature 090 "Seal":

- A5: Viton GLT
- C1: Kalrez



- Dimensions of the horn antenna (L, Ød): → 68
- Dimensions of the process connection (ØA, ØD, b): → 68

FMR51: Version T ≤ 150 °C (302 °F); with antenna extension

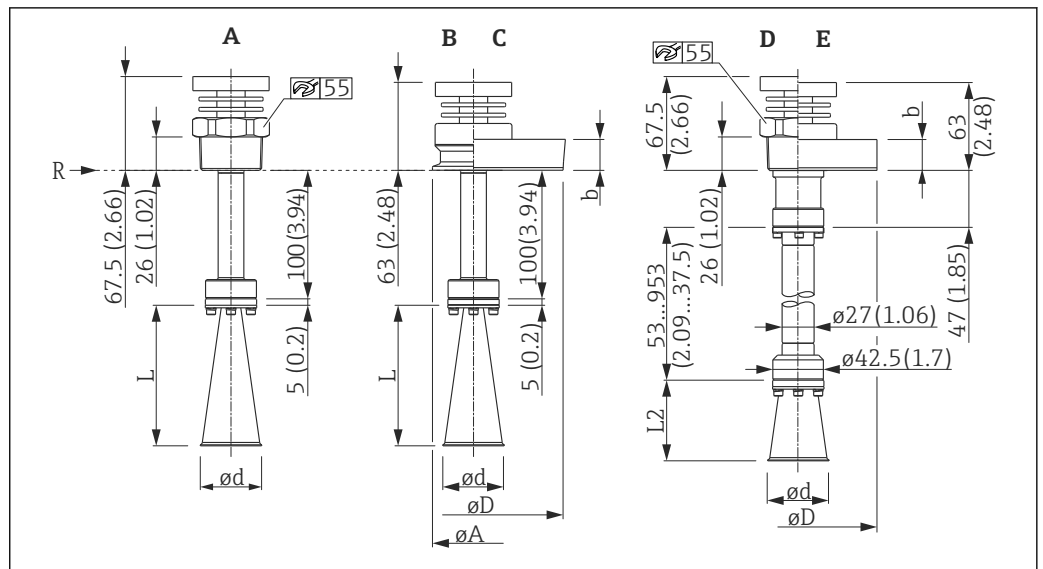

A0023384

24 MR51: Version T < 150 °C (302 °F); with antenna extension; dimensions: mm (in)

- A Process connections: Thread; Accessory mounted: 100mm/4" antenna extension
- B Prozessanschluss: Tri-Clamp ISO2852; Accessory mounted: 100mm/4" antenna extension
- C Process connection: Flange 316L; Accessory mounted: 100mm/4" antenna extension
- D Process connection: Thread; Accessory mounted: mm/inch antenna extension
- E Process connection: Flange 316L; Accessory mounted: mm/inch antenna extension
- R Reference point of the measurement

Valid for the following device versions

■ Feature 090 "Seal":

- A5: Viton GLT
- C1: Kalrez

■ Feature 610 "Accessory mounted"

- OM: 100mm/4" antenna extension (diagrams A, B, C)
- OU: mm antenna extension (100 ... 1000 mm) (diagrams D, E)
- OV: inch antenna extension (3,94 ... 39,4 in) (diagrams D, E)



- Dimensions of the horn antenna (L, L2, ød): → 68
- Dimensions of the process connections (øA, øD, b): → 68

FMR51: Version T ≤ 250 °C (482 °F)

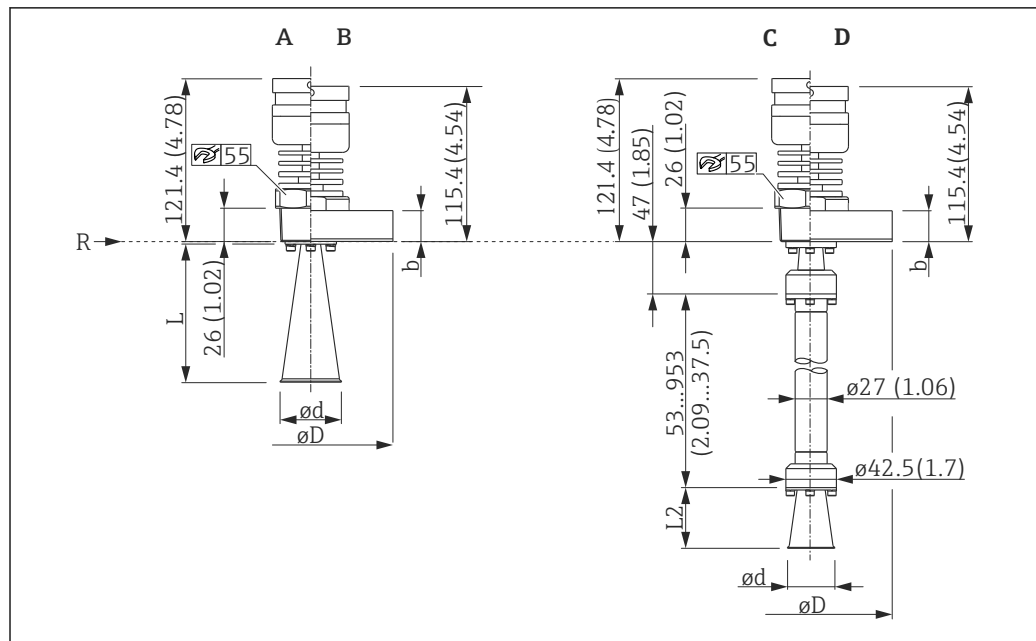

A0023385

25 FMR51: Version T < 250 °C (482 °F); dimensions: mm (in)

- A Process connection: Thread
 B Process connection: Flange 316L
 C Process connection: Thread; Accessory mounted: mm/inch antenna extension
 D Process connection: Flange 316L; Accessory mounted: mm/inch antenna extension
 R Reference point of the measurement

Valid for the following device versions

Feature 090 "Seal":

D3: Graphite, -40...250°C/-40...482°F



- Dimensions of the horn antenna (L, ød): → 68
- Dimensions of the process connection (øD, b): → 68

FMR51: Version $T \leq 450\text{ °C}$ (842 °F)

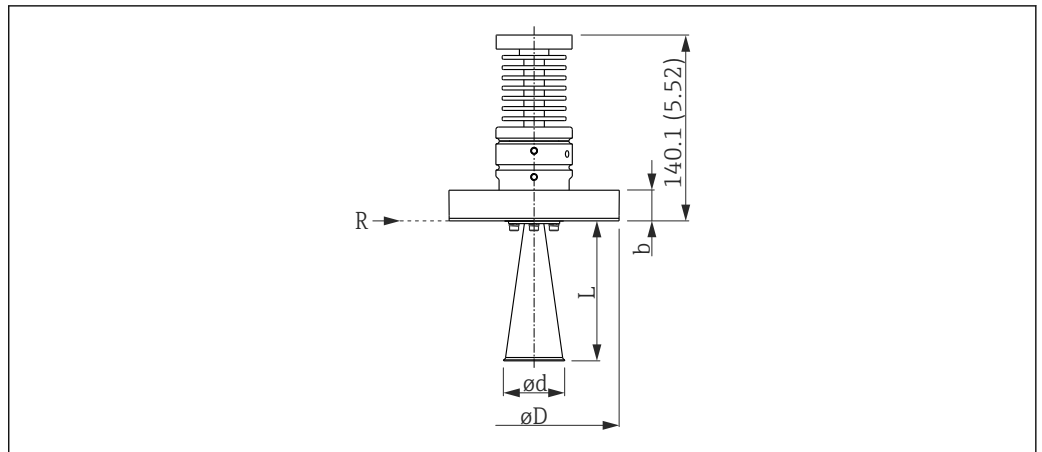

A0023386

26 FMR51: Version $T < 450\text{ °C}$ (842 °F); dimensions: mm (in)

Valid for the following device versions

Feature 090 "Seal":

D2: Graphite, -196...450°C/-321...842°F



- Dimensions of the horn antenna (L , $\varnothing d$): → 68
- Dimensions of the process connection ($\varnothing D$, b): → 68

FMR51: Dimensions of the horn antenna

Dimension	Feature 070 "Antenna"			
	BA: Horn 40mm/1-1/2"	BB: Horn 50mm/2"	BC: Horn 80mm/3"	BD: Horn 100mm/4"
L	86 mm (3.39 in)	115 mm (4.53 in)	211 mm (8.31 in)	282 mm (11.1 in)
L2	51 mm (2.01 in)	80 mm (3.15 in)	176 mm (6.93 in)	247 mm (9.72 in)
φd	φ40 mm (1.57 in)	φ48 mm (1.89 in)	φ75 mm (2.95 in)	φ95 mm (3.74 in)

FMR51: Dimensions of the process connections

Flanges according to EN1092-1 (suitable for DIN2527) ¹⁾

Pressure rating	Dimension	Nominal diameter ²⁾			
		DN50	DN80	DN100	DN150
PN10/16	b	18 mm (0.71 in)	20 mm (0.79 in)	20 mm (0.79 in)	22 mm (0.87 in)
	φD	φ165 mm (6.5 in)	φ200 mm (7.87 in)	φ220 mm (8.66 in)	φ285 mm (11.2 in)
PN25/40	b	20 mm (0.79 in)	24 mm (0.94 in)	24 mm (0.94 in)	-
	φD	φ165 mm (6.5 in)	φ200 mm (7.87 in)	φ235 mm (9.25 in)	-
PN63	b	-	-	30 mm (1.18 in)	-
	φD	-	-	φ250 mm (9.84 in)	-
PN100	b	-	-	36 mm (1.42 in)	-
	φD	-	-	φ265 mm (10.4 in)	-

- 1) For flanges with a higher pressure rating than those listed in the product structure please contact Endress +Hauser.
- 2) see feature 100 "Process connection"

Flanges according to JIS B2220 ¹⁾

Pressure rating ²⁾	Dimension	Nominal diameter ²⁾			
		50A	80A	100A	150A
10K	b	16 mm (0.63 in)	18 mm (0.71 in)	18 mm (0.71 in)	22 mm (0.87 in)
	φD	φ155 mm (6.1 in)	φ185 mm (7.28 in)	φ210 mm (8.27 in)	φ280 mm (11 in)
63K	b	-	-	44 mm (1.73 in)	-
	φD	-	-	φ270 mm (10.6 in)	-

- 1) For flanges with a higher pressure rating than those listed in the product structure please contact Endress +Hauser.
- 2) see feature 100 "Process connection"

Flanges according to ANSI B16.5¹⁾

Pressure rating ²⁾	Dimension	Nominal diameter ²⁾			
		2"	3"	4"	6"
150 lbs	b	19.1 mm (0.75 in)	23.9 mm (0.94 in)	23.9 mm (0.94 in)	25.4 mm (1 in)
	φD	φ152.4 mm (6 in)	φ190.5 mm (7.5 in)	φ228.6 mm (9 in)	φ279.4 mm (11 in)
300 lbs	b	22.4 mm (0.88 in)	28.4 mm (1.12 in)	31.8 mm (1.25 in)	25.4 mm (1 in)
	φD	φ165.1 mm (6.5 in)	φ209.5 mm (8.25 in)	φ254 mm (10 in)	φ279.4 mm (11 in)

- 1) For flanges with a higher pressure rating than those listed in the product structure please contact Endress+Hauser.
- 2) see feature 100 "Process connection"

Tri-Clamp according to ISO 2852

Dimension	Nominal diameter ¹⁾	
	DN40-51 (2")	DN70-76.1 (3")
A	64 mm (2.52 in)	91 mm (3.58 in)

- 1) see feature 100 "Process connection"

FMR52 with dairy coupling DIN11851

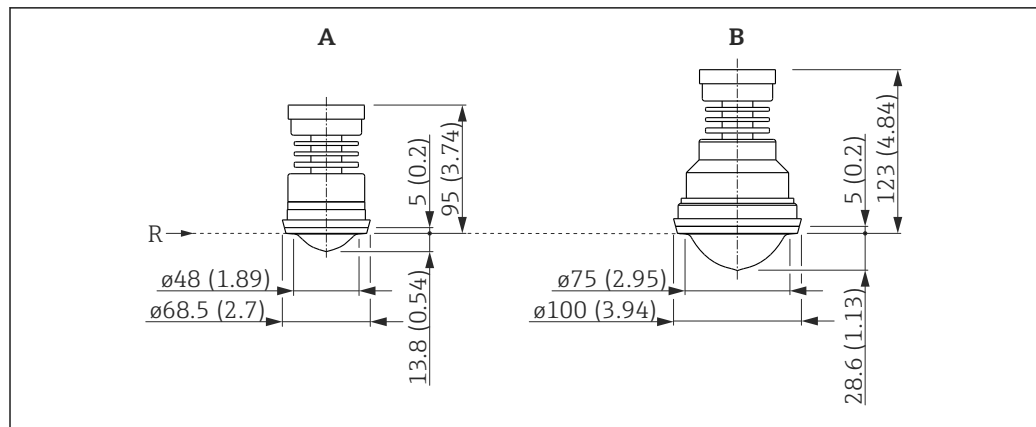

A0023387

27 FMR52 with dairy coupling DIN11851; dimensions: mm (in)

A Antenna: Horn 50mm/2"; Process connection DIN11851 DN50 PN25

B Antenna: Horn 80mm/3"; Process connection DIN11851 DN80 PN25

R Reference point of the measurement

Valid for the following device versions:

Feature 100 "Process connection"

- MRK: DIN11851 DN50 PN25 slotted nut, PTFE>316L (diagram A)
- MTK: DIN11851 DN80 PN25 slotted nut, PTFE>316L (diagram B)

FMR52 with Tri-Clamp ISO2852

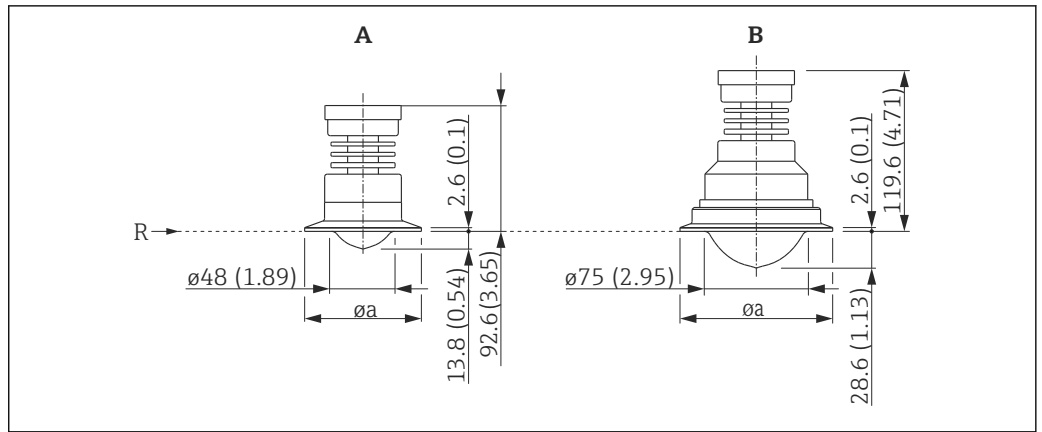

A0023388

28 FMR52 with Tri-Clamp ISO2852; dimensions: mm (in)

A Antenna: Horn 50mm/2"

B Antenna: Horn 80mm/3"

R Reference point of the measurement

Antenna ¹⁾	BO: "Horn 50mm/2"		BP: Horn 80mm/3"
Process connection ²⁾	TDK: Tri-Clamp DN40-51 (2")	TFK: Tri-Clamp DN70-76.1 (3")	THK: Tri-Clamp DN101.6 (4")
ϕa	$\phi 64$ mm (2.52 in)	$\phi 91$ mm (3.58 in)	$\phi 119$ mm (4.69 in)

1) Feature 070 of the product structure

2) Feature 100 of the product structure

FMR52 with flange

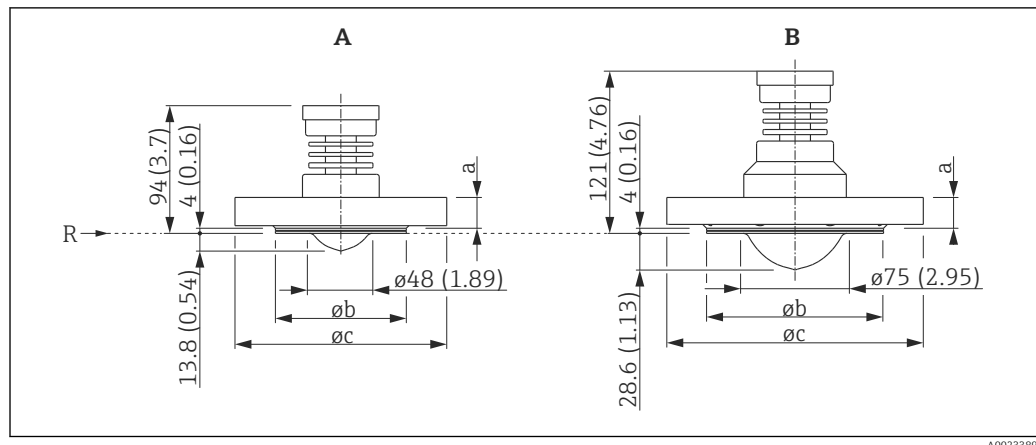

A0023389

29 Dimensions FMR52 with flange; dimensions: mm (in)

A Antenna: Horn 50mm/2"

B Antenna: Horn 80mm/3"

R Reference point of the measurement

Flanges according to EN1092-1 (suitable for DIN2527)

Antenna ¹⁾	BO: Horn 50mm/2"	BP: Horn 80mm/3"		
Process connection ²⁾	CFK: Flange DN50	CGK: Flange DN80	CHK: Flange DN100	CJK: Flange DN150
a	20 mm (0.79 in)	20 mm (0.79 in)	20 mm (0.79 in)	22 mm (0.87 in)
ϕ_b	$\phi 102$ mm (4.02 in)	$\phi 138$ mm (5.43 in)	$\phi 158$ mm (6.22 in)	$\phi 212$ mm (8.35 in)
ϕ_c	$\phi 165$ mm (6.5 in)	$\phi 200$ mm (7.87 in)	$\phi 220$ mm (8.66 in)	$\phi 285$ mm (11.2 in)

1) Feature 70 of the product structure

2) Feature 100 of the product structure

Flanges according to ANSI B16.5

Antenna ¹⁾	BO: Horn 50mm/2"	BP: Horn 80mm/3"		
Process connection ²⁾	FK: Flange 2"	AGK: Flange 3"	AHK: Flange 4"	AJK: Flange 6"
a	19.1 mm (0.75 in)	23.9 mm (0.94 in)	23.9 mm (0.94 in)	25.4 mm (1 in)
ϕ_b	$\phi 92$ mm (3.62 in)	$\phi 127$ mm (5 in)	$\phi 158$ mm (6.22 in)	$\phi 212$ mm (8.35 in)
ϕ_c	$\phi 152.4$ mm (6 in)	$\phi 190.5$ mm (7.5 in)	$\phi 228.6$ mm (9 in)	$\phi 279.4$ mm (11 in)

1) Feature 70 of the product structure

2) Feature 100 of the product structure

Flanges according to JIS B2220

Antenna ¹⁾	BO: Horn 50mm/2"	BP: Horn 80mm/3"		
Process connection ²⁾	KFK: Flange 10K 50A	KGK: Flange 10K 80A	KHK: Flange 10K 100A	KJK: Flange 10K 150A
a	16 mm (0.63 in)	18 mm (0.71 in)	18 mm (0.71 in)	22 mm (0.87 in)
ϕ_b	$\phi 96$ mm (3.78 in)	$\phi 127$ mm (5 in)	$\phi 151$ mm (5.94 in)	$\phi 212$ mm (8.35 in)
ϕ_c	$\phi 155$ mm (6.1 in)	$\phi 185$ mm (7.28 in)	$\phi 210$ mm (8.27 in)	$\phi 280$ mm (11 in)

1) Feature 70 of the product structure

2) Feature 100 of the product structure

Weight

Housing

Part	Weight
Housing GT18 - stainless steel	approx. 4.5 kg (9.9 lb)
Housing GT19 - plastic	approx. 1.2 kg (2.7 lb)
Housing GT20 - aluminium	approx. 1.9 kg (4.2 lb)

Antenna and process connection

Device	Weight of antenna and process connection
FMR51	max. 3.0 kg (6.6 lb) + weight of flange ¹⁾
FMR52	max. 4 kg (8.8 lb) + weight of flange ¹⁾

1) For the weight of the flange refer to Technical Information TI00426F.

Materials: GT18 housing

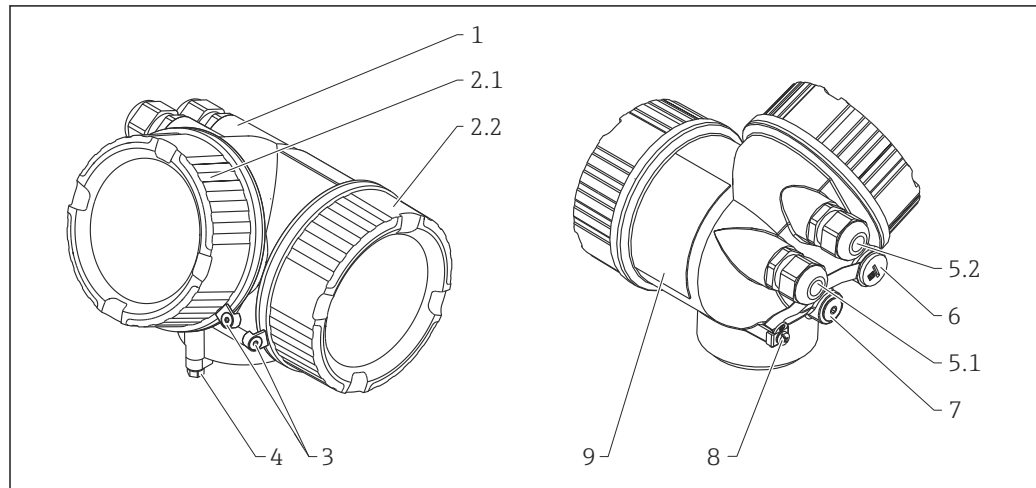

A0013788

No.	Part	Material
1	Housing	CF-3M (316L, 1.4404)
2.1	Cover of the electronics compartment	<ul style="list-style-type: none"> ▪ Cover: CF-3M (316L, 1.4404) ▪ Window: glass ▪ Cover seal: EPDM ▪ Seal of the window: NBR ▪ Thread-coating: Graphite-based lubricant varnish
2.2	Cover of the terminal compartment	<ul style="list-style-type: none"> ▪ Cover: CF-3M (316L, 1.4404) ▪ Cover seal: EPDM ▪ Thread-coating: Graphite-based lubricant varnish
3	Cover lock	<ul style="list-style-type: none"> ▪ Screw: A4 ▪ Clamp: 316L (1.4404)
4	Lock at the housing neck	<ul style="list-style-type: none"> ▪ Screw: A4-70 ▪ Clamp: 316L (1.4404)
5.1	Dummy plug, cable gland, adapter or plug (depending on the device version)	<ul style="list-style-type: none"> ▪ Dummy plug, depending on the device version: <ul style="list-style-type: none"> - PE - PBT-GF ▪ Cable gland: 316L (1.4404) or nickel-plated brass ▪ Adapter: 316L (1.4404/1.4435) ▪ Seal: EPDM ▪ M12 plug: Nickel-plated brass ¹⁾ ▪ 7/8" plug: 316 (1.4401) ²⁾
5.2	Dummy plug, cable gland or adapter (depending on the device version)	<ul style="list-style-type: none"> ▪ Dummy plug: 316L (1.4404) ▪ Cable gland: 316L (1.4404) or nickel-plated brass ▪ Adapter: 316L (1.4404/1.4435) ▪ Seal: EPDM
6	Dummy plug or M12 socket (depending on the device version)	<ul style="list-style-type: none"> ▪ Dummy plug: 316L (1.4404) ▪ M12 socket: 316L (1.4404)
7	Pressure relief stopper	316L (1.4404)
8	Ground terminal	<ul style="list-style-type: none"> ▪ Screw: A4 ▪ Spring washer: A4 ▪ Clamp: 316L (1.4404) ▪ Holder: 316L (1.4404)
9	Nameplate	<ul style="list-style-type: none"> ▪ Plate: 316L (1.4404) ▪ Groove pin: A4 (1.4571)

1) For the version with M12 plug the sealing material is Viton.

2) For the version with 7/8" plug, the sealing material is NBR.

Materials: GT19 housing

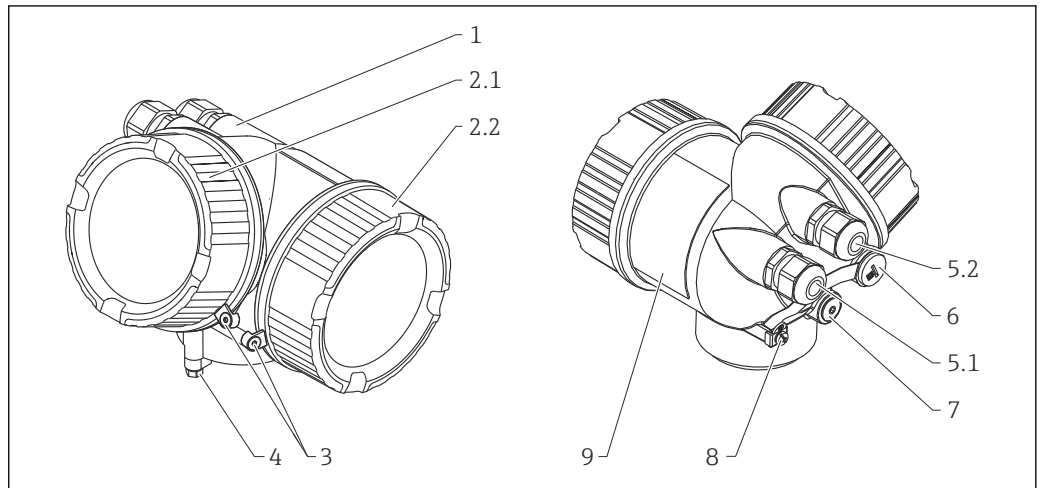

A0013788

No.	Part	Material
1	Housing	PBT
2.1	Cover of the electronics compartment	<ul style="list-style-type: none"> ▪ Cover, depending on the device version: <ul style="list-style-type: none"> - PA (see-through cover) - PBT (non-transparent cover) ▪ Cover seal: EPDM ▪ Thread-coating: Graphite-based lubricant varnish
2.2	Cover of the terminal compartment	<ul style="list-style-type: none"> ▪ Cover: PBT ▪ Cover seal: EPDM ▪ Thread-coating: Graphite-based lubricant varnish
4	Lock at the housing neck	<ul style="list-style-type: none"> ▪ Screw: A4-70 ▪ Clamp: 316L (1.4404)
5.1	Dummy plug, cable gland, adapter or plug (depending on the device version)	<ul style="list-style-type: none"> ▪ Dummy plug, depending on the device version: <ul style="list-style-type: none"> - PE - PBT-GF ▪ Cable gland, depending on the device version: <ul style="list-style-type: none"> - Nickel-plated brass (CuZn) - PA ▪ Adapter: 316L (1.4404/1.4435) ▪ Seal: EPDM ▪ M12 plug: Nickel-plated brass ¹⁾ ▪ 7/8" plug: 316 (1.4401) ²⁾
5.2	Dummy plug, cable gland or adapter (depending on the device version)	<ul style="list-style-type: none"> ▪ Dummy plug, depending on the device version: <ul style="list-style-type: none"> - PE - PBT-GF - Nickel-plated steel ▪ Cable gland, depending on the device version: <ul style="list-style-type: none"> - Nickel-plated brass (CuZn) - PA ▪ Adapter: 316L (1.4404/1.4435) ▪ Seal: EPDM
6	Dummy plug or M12 socket (depending on the device version)	<ul style="list-style-type: none"> ▪ Dummy plug: Nickel-plated brass (CuZn) ▪ M12 socket: Nickel-plated GD-Zn
7	Pressure relief stopper	Nickel-plated brass (CuZn)
8	Ground terminal	<ul style="list-style-type: none"> ▪ Screw: A2 ▪ Spring washer: A4 ▪ Clamp: 304 (1.4301) ▪ Holder: 304 (1.4301)
9	Nameplate	Sticker

1) For the version with M12 plug the sealing material is Viton.

2) For the version with 7/8" plug, the sealing material is NBR.

Materials: GT20 housing

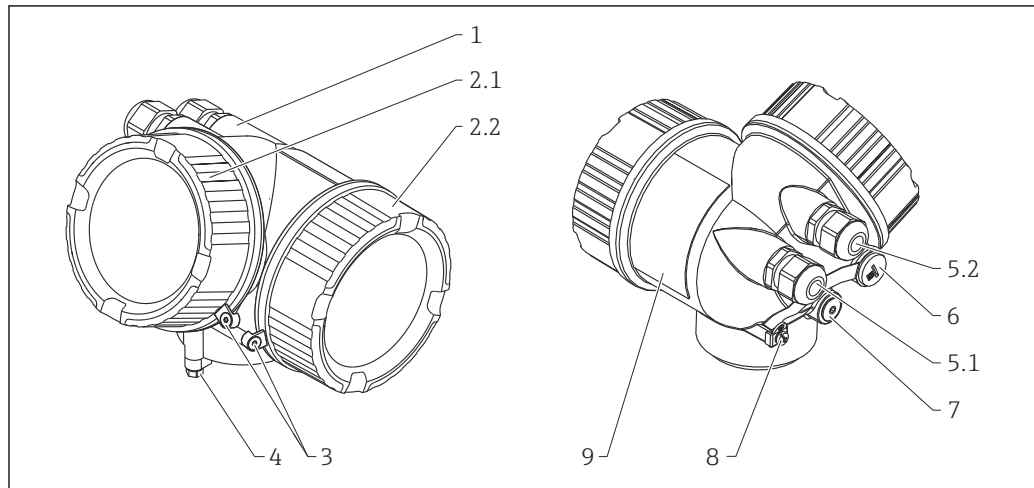

A0013788

Nr.	Part	Material
1	Housing, RAL 5012 (blue)	<ul style="list-style-type: none"> ■ Housing: AlSi10Mg(<0,1% Cu) ■ Coating: Polyester
2.1	Cover of the electronics compartment; RAL 7035 (gray)	<ul style="list-style-type: none"> ■ Cover: AlSi10Mg(<0,1% Cu) ■ Window: Glass ■ Cover seal: EPDM ■ Seal of the window: NBR ■ Thread-coating: Graphite-based lubricant varnish
2.2	Cover of the terminal compartment; RAL 7035 (gray)	<ul style="list-style-type: none"> ■ Cover: AlSi10Mg(<0,1% Cu) ■ Cover seal: EPDM ■ Thread-coating: Graphite-based lubricant varnish
3	Cover lock	<ul style="list-style-type: none"> ■ Screw: A4 ■ Clamp: 316L (1.4404)
4	Lock at the housing neck	<ul style="list-style-type: none"> ■ Screw: A4-70 ■ Clamp: 316L (1.4404)
5.1	Dummy plug, cable gland, adapter or plug (depending on the device version)	<ul style="list-style-type: none"> ■ Dummy plug, depending on the device version: <ul style="list-style-type: none"> - PE - PBT-GF ■ Cable gland, depending on the device version: <ul style="list-style-type: none"> - Nickel-plated brass (CuZn) - PA ■ Adapter: 316L (1.4404/1.4435) ■ Seal: EPDM ■ M12 plug: Nickel-plated brass ¹⁾ ■ 7/8" plug: 316 (1.4401) ²⁾
5.2	Dummy plug, cable gland or adapter (depending on the device version)	<ul style="list-style-type: none"> ■ Dummy plug, depending on the device version: <ul style="list-style-type: none"> - PE - PBT-GF - Nickel-plated steel ■ Cable gland, depending on the device version: <ul style="list-style-type: none"> - Nickel-plated brass (CuZn) - PA ■ Adapter: 316L (1.4404/1.4435) ■ Seal: EPDM
6	Dummy plug or M12 socket (depending on the device version)	<ul style="list-style-type: none"> ■ Dummy plug : Nickel-plated brass (CuZn) ■ M12 socket: Nickel-plated GD-Zn
7	Pressure relief stopper	Nickel-plated brass (CuZn)

Nr.	Part	Material
8	Ground terminal	<ul style="list-style-type: none"> ▪ Screw: A2 ▪ Spring washer: A2 ▪ Clamp: 304 (1.4301) ▪ Holder: 304 (1.4301)
9	Nameplate	Sticker

- 1) For the version with M12 plug the sealing material is Viton.
- 2) For the version with 7/8" plug, the sealing material is NBR.

Materials: Antenna and process connection

FMR51

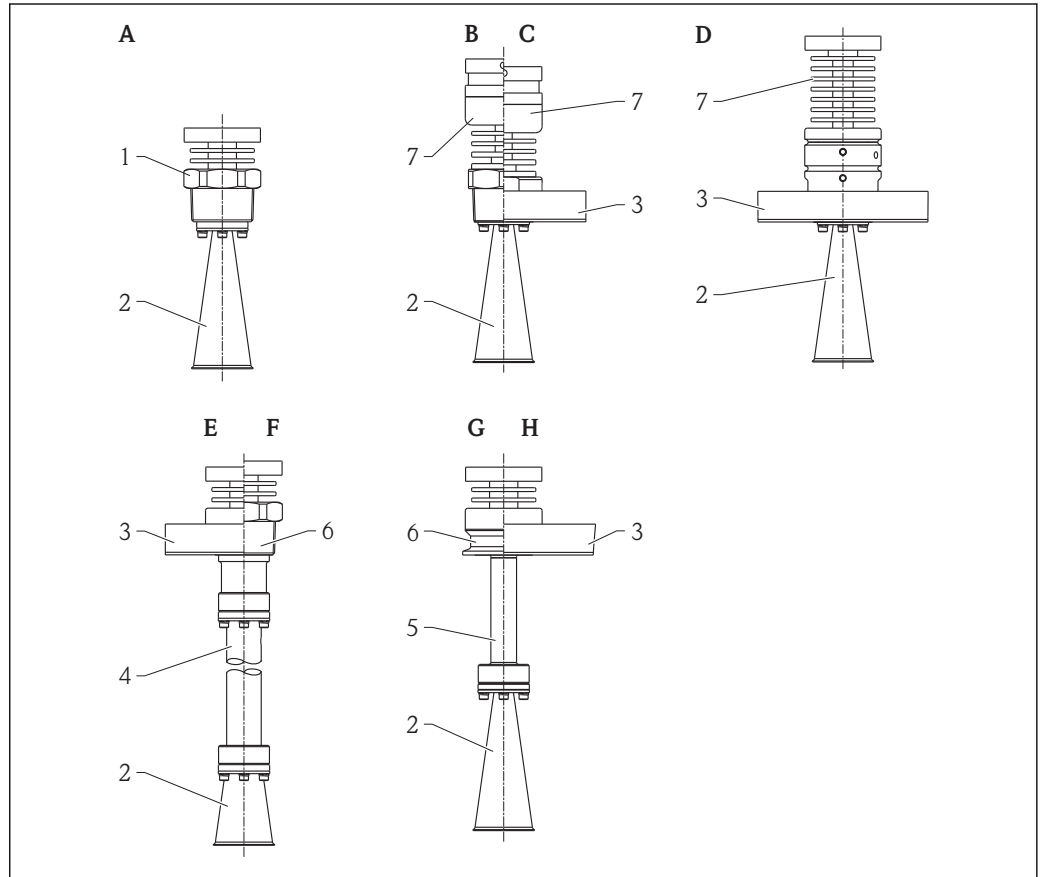

A0018961

- A Version with screw-in adapter
- B XT version with threaded connection
- C XT version with flange
- D HT version with flange
- E Version with flange and antenna extension > 100 mm (3.94 in) to 500 mm (19.7 in)
- F Version with threaded connection and antenna extension > 100 mm (3.94 in) to 500 mm (19.7 in)
- G Version with clamp adapter and antenna extension 100 mm (3.94 in)
- H Version with flange and antenna extension 100 mm (3.94 in)

Pos.	Part	Material	
1	Process adapter	316L (1.4404)	
	Locking washer		
2	Horn	316L (1.4404)	Hastelloy C22
	Screws	A4	Hastelloy C22
	Spring-lock washer (compact version)	A4	without spring-lock washer

Pos.	Part	Material		
	Nordlock washer (extension >100 mm, XT und HT version)	A4		without Nordlock washer
	Process separation cone	Standard: PTFE	XT: PEEK	HT: Al ₂ O ₃
	Seal	Standard: ▪ Viton: FKM ▪ Kalrez: FFKM (K6375)	XT: Graphite	HT: Graphite
3	Flange	316L (1.4404/1.4435) optionally Hastelloy C22 clad		
4	Tube extension + adapter	316L (1.4404)		
5	Extension process adapter	316L (1.4404)		
	Locking washer			
6	Process adapter	316L (1.4404)		
7	Housing adapter	316L (1.4404)		
	Temperature reduction (XT)	316L (1.4404)		
	Intermediate adapter (HT)	316L (1.4404)		
	Process adapter	316L (1.4404)		

FMR52

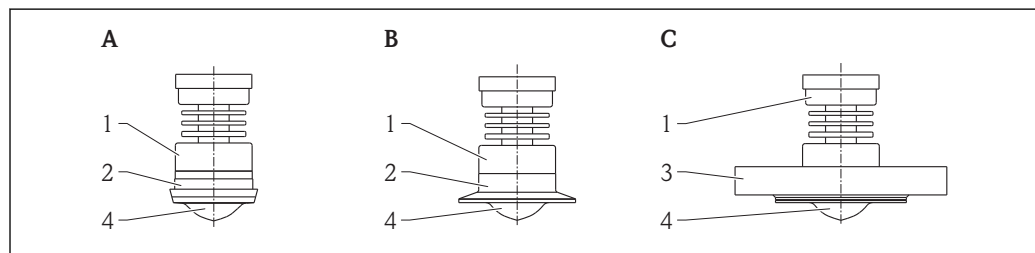

- A Dairy coupling
- B Clamp adapter
- C Flange version

Pos.	Part	Material
1	Adapter	304 (1.4301)
2	Process connection	316L (1.4435)
3	Flange	316L (1.4404/1.4435)
4	Cladding	PTFE (in accordance with FDA 21 CFR 177.1550 and USP <88> Class VI)

Materials: Weather protection cover

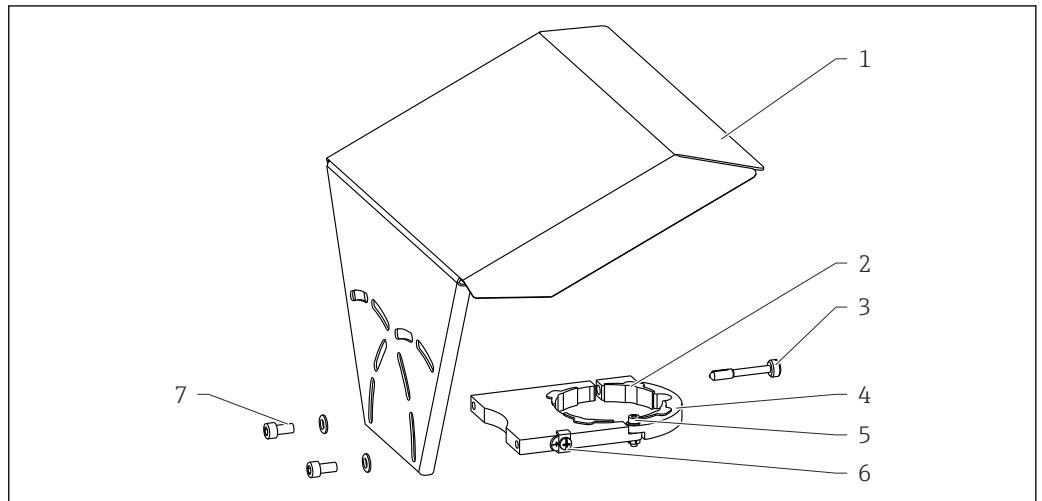

A0015473

No	Part: Material
1	Protection cover: 316L (1.4404)
2	Molded rubber part (4x): EPDM
3	Clamping screw: 316L (1.4404) + carbon fibre
4	Bracket: 316L (1.4404)
5	<ul style="list-style-type: none"> ▪ Cheese head screw: A4-70 ▪ Nut: A4 ▪ Spring washer: A4
6	Ground terminal <ul style="list-style-type: none"> ▪ Screw: A4 ▪ Spring washer: A4 ▪ Clamp: 316L (1.4404) ▪ Holder: 316L (1.4404)
7	<ul style="list-style-type: none"> ▪ Washer: A4 ▪ Cheese head screw: A4-70

Operability

Operating concept

Operator-oriented menu structure for user-specific tasks

- Commissioning
- Operation
- Diagnostics
- Expert level

Operating languages

- English (contained in every device)
- One additional language as ordered (feature 500 of the product structure)

Quick and safe commissioning

- Guided menus ("Make-it-run" wizards) for applications
- Menu guidance with brief explanations of the individual parameter functions

Reliable operation

- Standardized operation at the device and in the operating tools
- Data storage device (HistoROM) for process and measuring device data with event logbook available at all times - even if electronics modules are replaced

Efficient diagnostics increase measurement reliability

- Remedy information is integrated in plain text
- Diverse simulation options and line recorder functions

Local operation

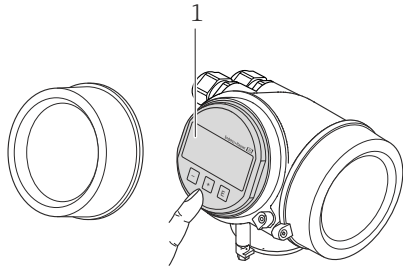
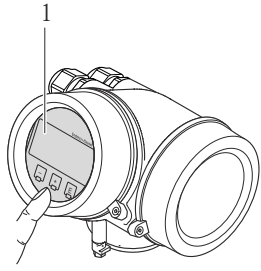
Order code for "Display; Operation", option C "SD02"	Order code for "Display; Operation", option E "SD03"
 <p style="text-align: right; font-size: small;">A0015544</p>	 <p style="text-align: right; font-size: small;">A0015546</p>
1 <i>Operation with pushbuttons</i>	1 <i>Operation with touch control</i>

Display elements

- 4-line display
- In the case of order code for "Display; Operation", option E: white background lighting; switches to red in event of device errors
- Format for displaying measured variables and status variables can be individually configured
- Permitted ambient temperature for the display: -20 to $+70$ °C (-4 to $+158$ °F)
The readability of the display may be impaired at temperatures outside the temperature range.

Operating elements

- In the case of order code "Display; Operation", Option C: local operation with 3 push buttons (⊖, ⊕, ⊗)
- In the case of order code for "Display; Operation", option E: external operation via touch control; 3 optical keys: ⊖, ⊕, ⊗
- Operating elements also accessible in various hazardous areas

Additional functionality

- Data backup function
The device configuration can be saved in the display module.
- Data comparison function
The device configuration saved in the display module can be compared to the current device configuration.
- Data transfer function
The transmitter configuration can be transmitted to another device using the display module.

Operation with remote display and operating module FHX50

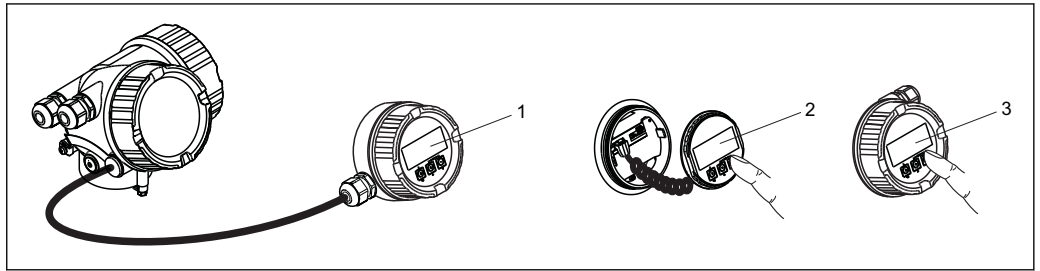

A0013137

30 FHX50 operating options

- 1 Housing of the remote display and operating module FHX50
- 2 Display and operating module SD02, push buttons; cover must be removed
- 3 Display and operating module SD03, optical keys; can be operated through the glass of the cover

Remote operation

Via HART protocol

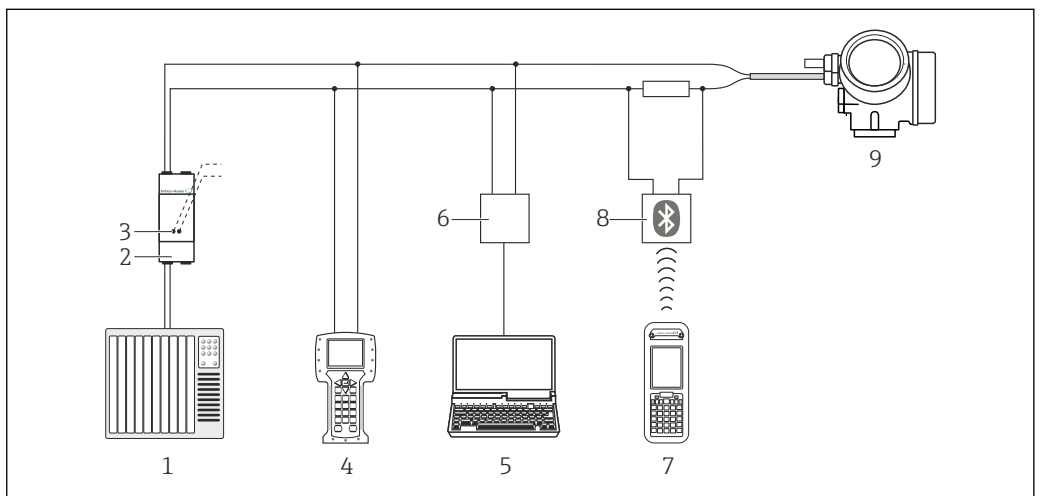

A0013764

31 Options for remote operation via HART protocol

- 1 PLC (programmable logic controller)
- 2 Transmitter power supply unit, e.g. RN221N (with communication resistor)
- 3 Connection for Commubox FXA191, FXA195 and Field Communicator 375, 475
- 4 Field Communicator 475
- 5 Computer with operating tool (e.g. FieldCare, AMS Device Manager, SIMATIC PDM)
- 6 Commubox FXA191 (RS232) or FXA195 (USB)
- 7 Field Xpert SFX350/SFX370
- 8 VIATOR Bluetooth modem with connecting cable
- 9 Transmitter

Via PROFIBUS PA protocol

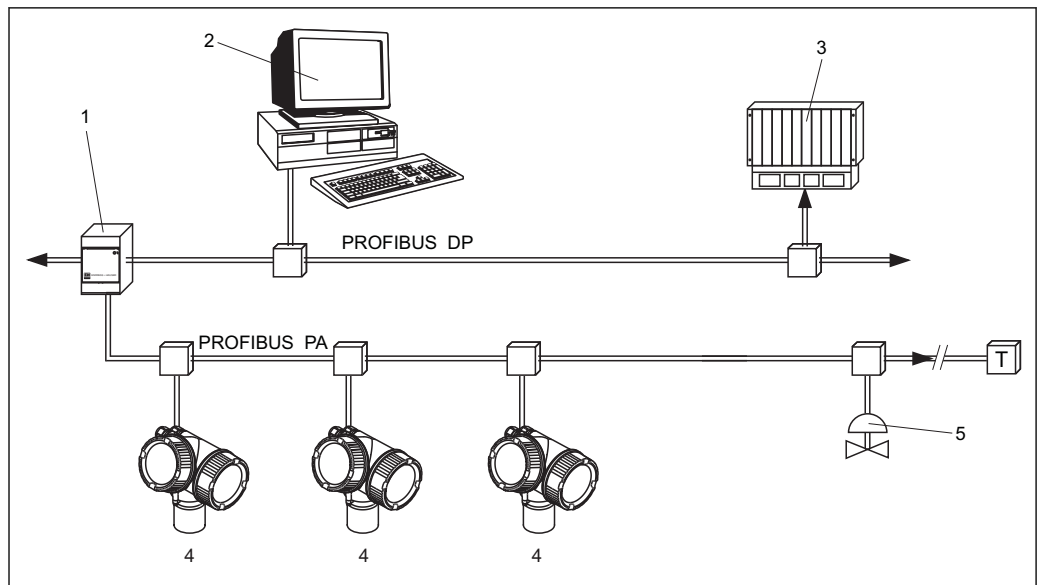

A0015775

- 1 Segment coupler
- 2 Computer with Profiboard/Proficard and operating tool (e.g. FieldCare)
- 3 PLC (Programmable Logic Controller)
- 4 Transmitter
- 5 Additional functions (valves etc.)

Via FOUNDATION Fieldbus

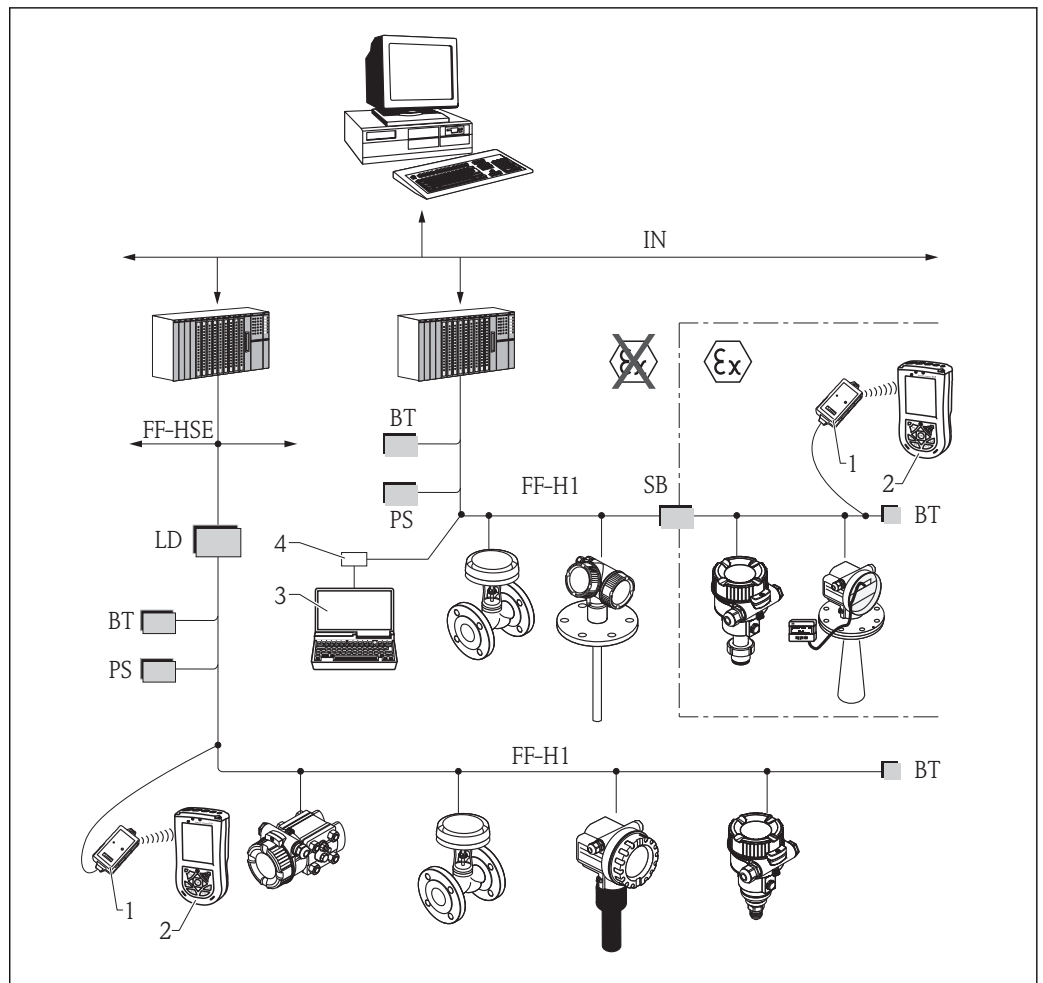

32 FOUNDATION Fieldbus system architecture with associated components

- 1 FFblue Bluetooth modem
- 2 Field Xpert SFX350/SFX370
- 3 FieldCare
- 4 NI-FF interface card

IN	Industrial network
FF-HSE	High Speed Ethernet
FF-H1	FOUNDATION Fieldbus-H1
LD	Linking Device FF-HSE/FF-H1
PS	Bus Power Supply
SB	Safety Barrier
BT	Bus Terminator

Via service interface (CDI)

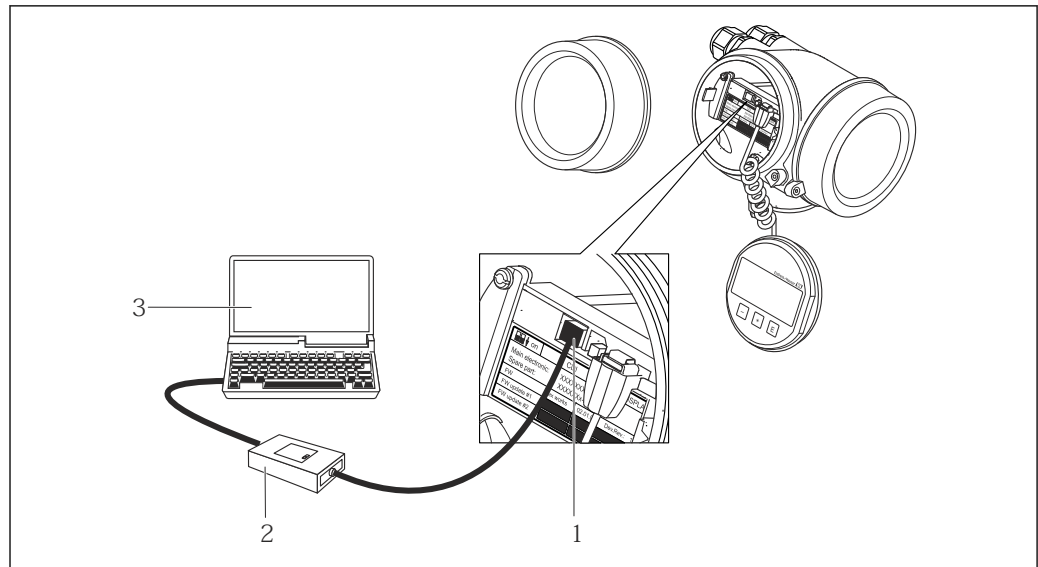

A0014019

- 1 Service interface (CDI) of the measuring device (= Endress+Hauser Common Data Interface)
- 2 Commubox FXA291
- 3 Computer with "FieldCare" operating tool

Integration in tank gauging system

The Endress+Hauser Tank Side Monitor NRF590 provides integrated communications for sites with multiple tanks, each with one or more sensors on the tank, such as radar, spot or average temperature, capacitive probe for water detection and/or pressure sensors. Multiple protocols out of the Tank Side Monitor guarantee connectivity to nearly any of the existing industry standard tank gauging protocols. Optional connectivity of analog 4...20 mA sensors, digital I/O and analog output simplify full tank sensor integration. Use of the proven concept of the intrinsically safe HART bus for all on-tank sensors yields extremely low wiring costs, while at the same time providing maximum safety, reliability and data availability.

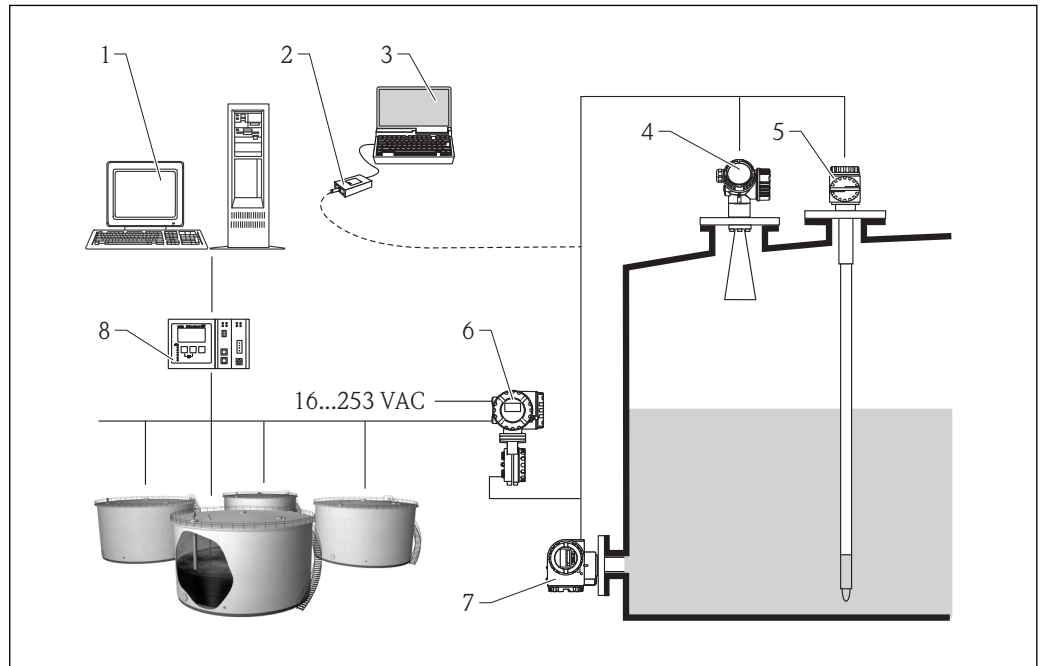

A0017982

33 The complete measuring system consists of:

- 1 Tankvision workstation
- 2 Commubox FXA195 (USB) - optional
- 3 Computer with operating tool (ControlCare) - optional
- 4 Level measuring device
- 5 Temperature measuring device
- 6 Tank Side Monitor NRF590
- 7 Pressure measuring device
- 8 Tankvision Tank Scanner NXA820

System integration via Fieldgate

Vendor Managed Inventory

By using Fieldgates to interrogate tank or silo levels remotely, suppliers of raw materials can provide their regular customers with information about the current supplies at any time and, for example, account for them in their own production planning. For their part, the Fieldgates monitor the configured level limits and, if required, automatically activate the next supply. The spectrum of options here ranges from a simple purchasing requisition via e-mail through to fully automatic order administration by coupling XML data into the planning systems on both sides.

Remote maintenance of measuring equipment

Fieldgates not only transfer the current measured values, they also alert the responsible standby personnel, if required, via e-mail or SMS. In the event of an alarm or also when performing routine checks, service technicians can diagnose and configure connected HART devices remotely. All that is required for this is the corresponding HART operating tool (e.g. FieldCare, ...) for the connected device. Fieldgate passes on the information transparently, so that all options for the respective operating software are available remotely. Some on-site service operations can be avoided by using remote diagnosis and remote configuration and all others can at least be better planned and prepared.

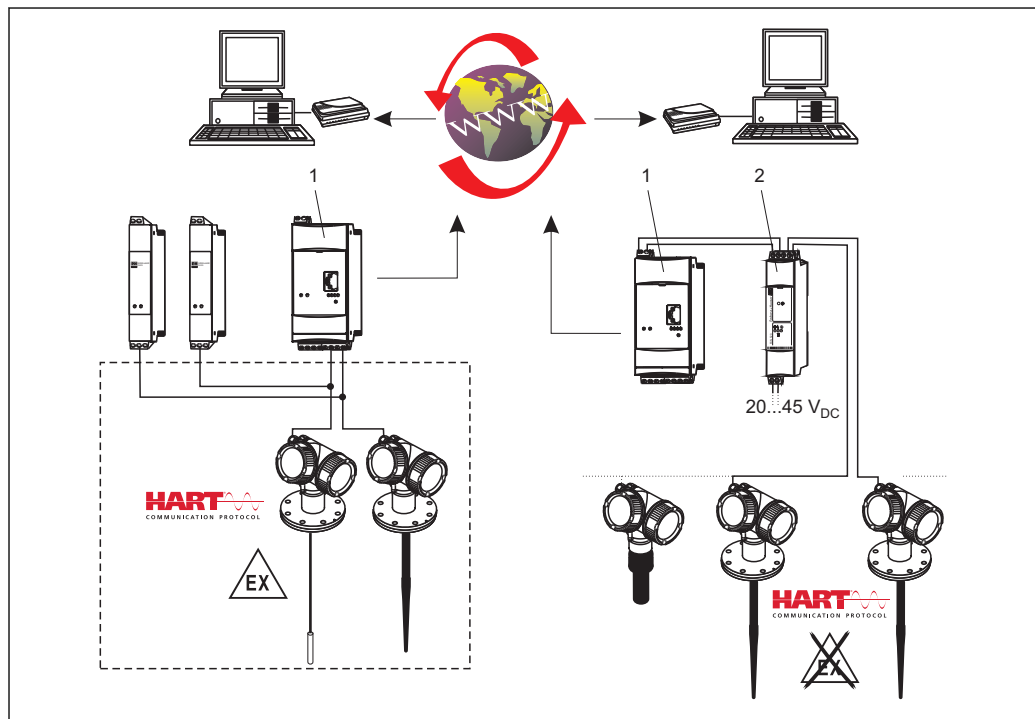





34 The complete measuring system consists of devices and:

- 1 Fieldgate FXA520
- 2 Multidrop Connector FXN520

i The number of instruments which can be connected in multidrop mode can be calculated by the "FieldNetCalc" program. A description of this program can be found in Technical Information TI 400F (Multidrop Connector FXN520). The program is available from your Endress+Hauser sales organisation or in the internet at: www.de.endress.com/Download (text search = "Fieldnetcalc").

Certificates and approvals

CE mark	<p>The measuring system meets the legal requirements of the applicable EC guidelines. These are listed in the corresponding EC Declaration of Conformity together with the standards applied.</p> <p>Endress+Hauser confirms successful testing of the device by affixing to it the CE mark.</p>
C-Tick symbol	<p>The measuring system meets the EMC requirements of the "Australian Communications and Media Authority (ACMA)".</p>
Ex approval	<ul style="list-style-type: none"> ▪ ATEX ▪ IEC Ex ▪ CSA ▪ FM ▪ NEPSI ▪ KC ▪ INMETRO ▪ TIIS (in preparation) <p>Additional safety instructions must be observed for applications in hazardous areas. They are contained in the separate "Safety Instructions" (XA) document, which is included in the scope of delivery. Reference is made to the XA on the nameplate of the device.</p> <p> Details on the available certificates as well as the associated XAs can be found in the Associated documentation chapter in the Safety instructions section: →  103.</p>
Dual seal according to ANSI/ISA 12.27.01	<p>The devices have been designed according to ANSI/ISA 12.27.01 as dual seal devices, allowing the user to waive the use and save the cost of installing external secondary process seals in the conduit as required by the process sealing sections of ANSI/NFPA 70 (NEC) and CSA 22.1 (CEC). These instruments comply with the North-American installation practice and provide a very safe and cost-saving installation for pressurized applications with hazardous fluids.</p> <p>Further information can be found in the Safety Instructions (XA) of the relevant devices.</p>
Functional Safety	<p>Used for level monitoring (MIN, MAX, range) up to SIL 3 (homogeneous or inhomogeneous redundancy), independently assessed by TÜV Rheinland as per IEC 61508. Other information see documentation SD01087F: "Functional Safety Manual".</p>
WHG	<p>WHG approval: Z-65.16-524</p>
Sanitary compatibility	<p>FMR52 with flange cladding made of PTFE conforms to FDA 21 CFR 177.1550 and USP <88> Class VI</p> <p>3A and EHEDG approval with Tri-Clamp and DIN11851 process connection.</p> <p> To avoid risk of contamination, install according to the "Hygienic Equipment Design Criteria (HDC)" as stated in the Subgroup Design Principles of the EHEDG, Doc. 8 from April 2004.</p> <p>Suitable fittings and seals must be used to ensure hygiene-compliant design according to the specifications of 3-A SSI and EHEDG.</p> <p> The leak-tight connections can be cleaned with the cleaning methods usually used in this industry without leaving residues.</p> <p> The 316L housing (GT18), option B in the order attribute 40, is not suitable for applications which need a 3A approval.</p>
NACE MR 0175 / ISO 15156	<p>For FMR51 and FMR54:</p> <ul style="list-style-type: none"> ▪ The wetted, metallic materials comply with the requirements of NACE MR 0175 / ISO 15156. ▪ Declaration of conformity: see product structure, feature 580, option JB.

NACE MR 0103

For FMR51 and FMR54:

- The wetted, metallic materials comply with the requirements of NACE MR 0103.
- The certificate of compliance is based on NACE MR 0175.
The hardness and the intercrystalline corrosion have been tested, as well as the heat treatment (solution annealed) has been carried out. The used materials comply therefore with the requirements of NACE MR 0103.
- Declaration of conformity: see product structure, feature 580, option JE.

Pressure Equipment Directive

The Micropilot is not subject to the scope of the Pressure Equipment Directive 97/23/EC, as it does not have a pressure-bearing housing according to article 1, section 2.1.4 of the directive.

Marine certificate (in preparation)

in preparation

Radio standard EN302729-1/2

The devices Micropilot FMR50, FMR51, FMR52, FMR56 and FMR57 are conform with the LPR (Level Probing Radar) standard EN302729-1/2. The devices are allowed to be used inside or outside of closed bins or tanks in countries of the EU and the EFTA. Precondition is that the country itself already has implemented the directive.

At present, the following countries have already implemented the directive:

Belgium, Bulgaria, Germany, Denmark, Estonia, France, Greece, Great Britain, Ireland, Iceland, Italy, Liechtenstein, Lithuania, Latvia, Malta, Netherland, Norway, Austria, Poland, Romania, Sweden, Switzerland, Slovakia, Spain, Czech Republic and Cyprus.

All countries not mentioned above are at present in the implementation phase.

For the use of the devices outside of closed bins or tanks, the following has to be observed:

1. The installation has to be done by trained personnel.
2. The antenna of the device has to be mounted on a fixed place and vertically to the bottom.
3. The mounting place has to be in a distance of at least 4 km to the mentioned astronomical stations or an appropriate permission has to be issued by the national authority. If the device is mounted at a distance of 4 to 40 km from the stations mentioned, the maximum mounting height is restricted to 15 m (49 ft).

Astronomical stations

Country	Name of the station	Geographical latitude	Geographical longitude
Germany	Effelsberg	50°31'32" N	06°53'00" E
Finland	Metsähovi	60°13'04" N	24°23'37" E
	Tuorla	60°24'56" N	24°26'31" E
France	Plateau de Bure	44°38'01" N	05°54'26" E
	Floirac	44°50'10" N	00°31'37" W
United Kingdom	Cambridge	52°09'59" N	00°02'20" E
	Damhall	53°09'22" N	02°32'03" W
	Jodrell Bank	53°14'10" N	02°18'26" W
	Knockin	52°47'24" N	02°59'45" W
	Pickmere	53°17'18" N	02°26'38" W
Italy	Medicina	44°31'14" N	11°38'49" E
	Noto	36°52'34" N	14°59'21" E
	Sardinia	39°29'50" N	09°14'40" E
Poland	Krakow Fort Skala	50°03'18" N	19°49'36" E
Russia	Dmitrov	56°26'00" N	37°27'00" E
	Kalyazin	57°13'22" N	37°54'01" E
	Pushchino	54°49'00" N	37°40'00" E
	Zelenchukskaya	43°49'53" N	41°35'32" E

Country	Name of the station	Geographical latitude	Geographical longitude
Sweden	Onsala	57°23'45" N	11°55'35" E
Switzerland	Bleien	47°20'26" N	08°06'44" E
Spain	Yebes	40°31'27" N	03°05'22" W
	Robledo	40°25'38" N	04°14'57" W
Hungary	Penc	47°47'22" N	19°16'53" E

 In general the requirements of EN 302729-1/2 have to be taken in consideration.

Radio standard EN302372-1/2 The devices Micropilot FMR50, FMR51, FMR52, FMR53, FMR54, FMR56 and FMR57 are conform with the TLPR (Tanks Level Probing Radar) standard EN302372-1/2 and can always be used in closed tanks or bins. For installation, points a to f in Annex B of EN302372-1 have to be taken into account.

FCC / Industry Canada This device complies with Part 15 of the FCC rules. Operation is subject to the following two conditions: (1) This device may not cause harmful interference, and (2) this device must accept any interference received, including interference that may cause undesired operation.

Canada CNR-Gen Section 7.1.3

This device complies with Industry Canada licence-exempt RSS standard(s). Operation is subject to the following two conditions: (1) This device may not interference, and (2) this device must accept any interference, including interference that may cause undesired operation of the device.

Le présent appareil est conforme aux CNR d'Industrie Canada applicables aux appareils radio exempts de licence. L'exploitation est autorisée aux deux conditions suivantes : (1) l'appareil ne doit pas produire de brouillage, et (2) l'utilisateur de l'appareil doit accepter tout brouillage radioélectrique subi, même si le brouillage est susceptible d'en compromettre le fonctionnement.

[Any] changes or modifications not expressly approved by the party responsible for compliance could void the user's authority to operate the equipment.

In addition, the devices FMR50¹⁰⁾, FMR51¹¹⁾, FMR52¹²⁾, FMR56 and FMR57 are compliant with the LPR (Level probe radar) regulation also for free space applications according to the FCC Code of Federal Regulations, CFR 47, Part 15, Sections 15.205, 15.207, 15.209, 15.256 for antenna sizes bigger than 50 mm (2.0 in)¹³⁾. For these applications the devices must be professionally installed in a downward operating position. In addition, the devices are not allowed to be mounted in a zone of 4 km around RAS stations and within a radius of 40 km around RAS stations the maximum operation height of devices is 15 m (49 ft) above ground.

Japanese radio approval The devices FMR50, FMR51, FMR52, FMR54 and FMR57 comply with the Japanese Radio Law, Article 6, Section 1(1).

CRN approval Some device versions have a CRN approval. Devices are CRN approved if the following two conditions are met:

- The device has a CSA approval (Product structure: Feature 010 "Approval")
- The device has a CRN approved process connection according to the following table.

Feature 100 of the product structure	Process connection
AFJ	NPS 2" Cl.150 RF, 316/316L
AFK	NPS 2" Cl.150, PTFE >316/316L
AFM	NPS 2" Cl.150, AlloyC >316/316L
AGJ	NPS 3" Cl.150 RF, 316/316L

10) Except of FMR50-#####BM* (Horn 40mm/1-1/2", PVDF encapsulated)
 11) Except for FMR51-#####BA* (Horn 40mm/1-1/2") and FMR51-#####BB* (Horn 50mm/2")
 12) Except for FMR52-#####BO* (Horn 50mm/2", flush mount)
 13)

Feature 100 of the product structure	Process connection
AGK	NPS 3" Cl.150, PTFE >316/316L
AGM	NPS 3" Cl.150, AlloyC >316/316L
AHJ	NPS 4" Cl.150 RF, 316/316L
AHK	NPS 4" Cl.150, PTFE >316/316L
AHM	NPS 4" Cl.150, AlloyC >316/316L
AJJ	NPS 6" Cl.150 RF, 316/316L
AJK	NPS 6" Cl.150, PTFE >316/316L
AJM	NPS 6" Cl.150, AlloyC >316/316L
ARJ	NPS 2" Cl.300 RF, 316/316L
ARM	NPS 2" Cl.300, AlloyC >316/316L
ASJ	NPS 3" Cl.300 RF, 316/316L
ASM	NPS 3" Cl.300, AlloyC >316/316L
ATJ	NPS 4" Cl.300 RF, 316/316L
ATM	NPS 4" Cl.300, AlloyC >316/316L
MRK	DIN11851 DN50 PN25 slotted nut, PTFE>316L
MTK	DIN11851 DN80 PN25 slotted nut, PTFE>316L
RGJ	Thread ANSI MNPT1-1/2, 316L
RVJ	Thread EN10226 R1-1/2, 316L
TDJ	Tri-Clamp ISO2852 DN40-51 (2"), 316L
TDK	Tri-Clamp ISO2852 DN40-51 (2"), PTFE>316L, 3A, EHEDG
TFJ	Tri-Clamp ISO2852 DN70-76.1 (3"), 316L
TFK	Tri-Clamp ISO2852 DN70-76.1 (3"), PTFE>316L, 3A, EHEDG
THK	Tri-Clamp ISO2852 DN101.6 (4"), PTFE>316L, 3A, EHEDG

- i** ■ Process connections without CRN approval are not included in this table.
- Refer to the product structure to see which process connections are available for a specific device type.
- CRN approved devices are marked with the registration number OF15872.5C on the nameplate.

i For device versions listed in the table below, the maximum allowed pressure is reduced if they have a CRN approval. For device versions not listed in the table below the pressure range as indicated in the "Process" chapter →  60 is not affected by the CRN approval.

Product	Antenna ¹⁾	Prozessanschluss ²⁾	Dichtung ³⁾	max. pressure
FMR52		TFK: Tri-Clamp 3"		10 bar (145 psi)
		THK: Tri-Clamp 4"		10 bar (145 psi)
FMR51			D2: Graphite (HT)	100 bar (1 450 psi)

- 1) Feature 070 of the product structure
 2) Feature 100 of the product structure
 3) Feature 090 of the product structure

Track record

FMR5x is the upgrade model of the corresponding FMR2xx series.

Test, Certificate

Feature 580 "Test, Certificate"	Designation	Available for
JA	3.1 Material certificate, wetted metallic parts, EN10204-3.1 inspection certificate	FMR51
JB	Conformity to NACE MR0175, wetted metallic parts	FMR51
JD	3.1 Material certificate, pressurized parts, EN10204-3.1 inspection certificate	FMR52
JE	Conformity to NACE MR0103, wetted metallic parts	FMR51
JF	Conformity to AD2000, wetted metallic parts: Material of all wetted/pressurized parts conform to AD2000 (Technical rules W2, W9, W10)	<ul style="list-style-type: none"> ■ FMR51 ■ FMR52
KD	Helium leak test, internal procedure, inspection certificate	FMR51
KE	Pressure test, internal procedure, inspection certificate	<ul style="list-style-type: none"> ■ FMR51 ■ FMR52
KG	3.1 Material certificate+PMI test (XRF), internal procedure, wetted metallic parts, EN10204-3.1 inspection certificate	<ul style="list-style-type: none"> ■ FMR51 ■ FMR52
KP	Liquid penetrant test AD2000-HP5-3(PT), wetted/pressurized metallic parts, inspection certificate	FMR51
KQ	Liquid penetrant test ISO23277-1 (PT), wetted/pressurized metallic parts, inspection certificate	FMR51
KR	Liquid penetrant test ASME VIII-1 (PT), wetted/pressurized metallic parts, inspection certificate	FMR51
KS	Welding documentation, wetted/pressurized seams consisting of <ul style="list-style-type: none"> ■ Drawing ■ WPQR (Welding Procedure Qualification Report) ■ WPS (Welding Process Specification) ■ Manufacturer Declaration 	FMR51
KV	Conformity to ASME B31.3: The dimensions, materials of construction, pressure / temperature ratings and identification markings of the device comply with the requirements of ASME B31.3	<ul style="list-style-type: none"> ■ FMR51 ■ FMR52

Other standards and guidelines

- EN 60529
Degrees of protection by housing (IP code)
- EN 61010-1
Protection Measures for Electrical Equipment for Measurement, Control, Regulation and Laboratory Procedures.
- IEC/EN 61326
"Emission in accordance with Class A requirements". Electromagnetic compatibility (EMC requirements)
- NAMUR NE 21
Electromagnetic compatibility (EMC) of industrial process and laboratory control equipment.
- NAMUR NE 43
Standardization of the signal level for the breakdown information of digital transmitters with analog output signal.
- NAMUR NE 53
Software of field devices and signal-processing devices with digital electronics
- NAMUR NE 107
Status classification as per NE107
- NAMUR NE 131
Requirements for field devices for standard applications
- IEC61508
Functional safety of electrical/electronic/programmable electronic safety-related systems

Ordering information

Ordering information

Detailed ordering information is available from the following sources:

- In the Product Configurator on the Endress+Hauser web site: www.endress.com → Choose your country → Products → Select measuring technology, software or components → Select product (picklists: measurement method, product family etc.) → Device support (right-hand column): Configure the selected product → The Product Configurator for the selected product is opened.
- From your Endress+Hauser Sales Center: www.addresses.endress.com



Product Configurator - the tool for individual product configuration

- Up-to-the-minute configuration data
- Depending on the device: Direct input of measuring point-specific information such as measuring range or operating language
- Automatic verification of exclusion criteria
- Automatic creation of the order code and its breakdown in PDF or Excel output format
- Ability to order directly in the Endress+Hauser Online Shop

3-point linearity protocol

 The following notes must be taken into account if option F3 ("3 point linearity protocol") has been selected in feature 550 ("Calibration").

The 3 points of the linearity protocol are defined as follows:

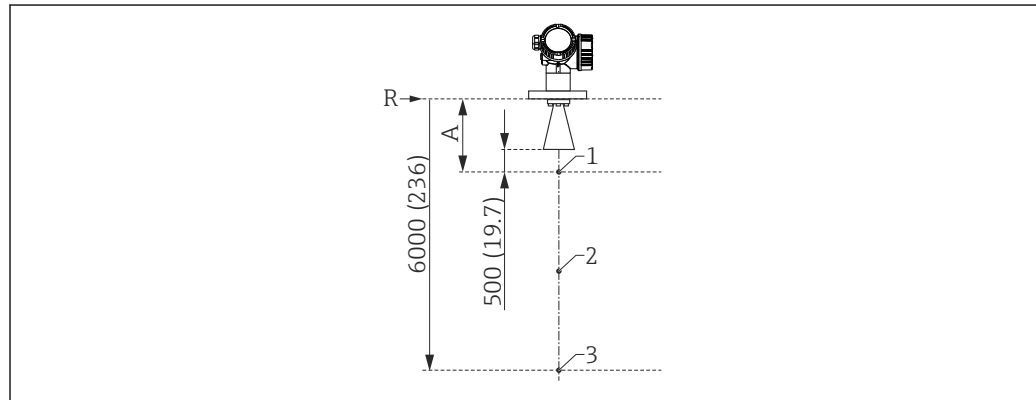

A0023272

 35 Points of the 3-point linearity protocol; Dimensions: mm (in)

- A Distance from reference point R to first measuring point
- R Reference point of the measurement
- 1 First measuring point
- 2 Second measuring point (centrally between first and third measuring point)
- 3 Third measuring point

Measuring point	Position
1 st measuring point	<ul style="list-style-type: none"> ■ At the distance A from the reference point ■ A = antenna length + antenna extension (if present) + 500 mm (19.7 in) ■ Minimum distance: $A_{\min} = 1000$ mm (39.4 in)
2 nd measuring point	centrally between 1 st and 3 rd measuring point
3 rd measuring point	6000 mm (236 in) below the reference point, R

 The position of the measuring points may vary by ± 1 cm (± 0.04 in).

 The linearity is checked under reference conditions.

5-point linearity protocol

i The following notes must be taken into account if option F4 ("5 point linearity protocol") has been selected in feature 550 ("Calibration").

The five points of the linearity protocol are evenly distributed across the measuring range (0% to 100%). In order to define the measuring range, **Empty calibration** (E) and **Full calibration** (F) have to be specified ¹⁴⁾.

The following restrictions have to be taken into account when defining E and F:

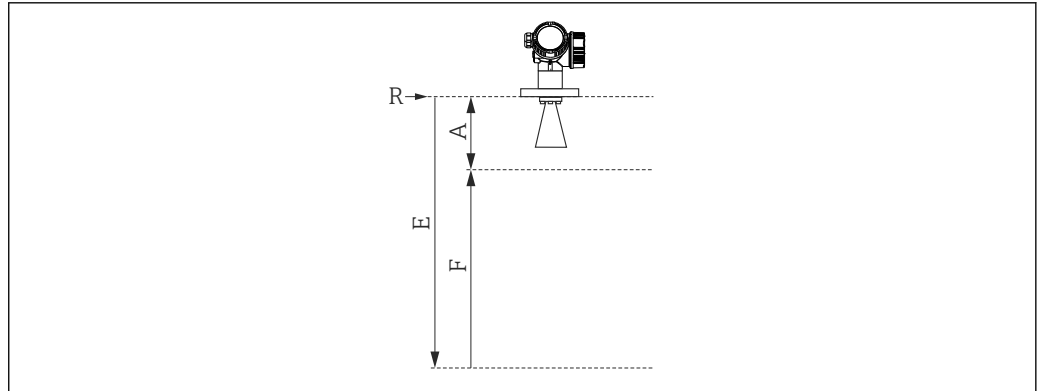

A0017983

Device version	Minimum distance between reference point (R) and 100% level	Minimum span	Maximum value for "Empty calibration"
FMR51/FMR52 Without antenna extension	$A \geq \text{antenna length} + 200 \text{ mm (8 in)}^1$	$F \geq 400 \text{ mm (16 in)}$	$E \leq 24 \text{ m (79 ft)}$
FMR51 with 100 mm/4" antenna extension ²⁾	$A \geq \text{antenna length} + \text{antenna extension} 100 \text{ mm (4 in)} + 200 \text{ mm (8 in)}$		
FMR51 with variable antenna extension ³⁾	$A \geq \text{antenna length} + \text{maximum antenna extension} 1000 \text{ mm (40 in)}^4) + 200 \text{ mm (8 in)}$		

- 1) Minimum value: $A \geq 400 \text{ mm (16 in)}$
- 2) Feature 610 "Accessory Mounted", option OM
- 3) Feature 610 "Accessory Mounted", option OU or OV
- 4) This value is independent of the actual size of the antenna extension.

i The linearity is checked under reference conditions.

i The selected values of **Empty calibration** and **Full calibration** are only used to record the linearity protocol and are reset to their probe specific default values thereafter. If values different from the default are required, they must be ordered as a customized parametrization → 96.

¹⁴⁾ If E and F are not specified, probe dependent default values will be used instead.



Customized parametrization

If the option IJ "Customized parametrization HART", IK "Customized parametrization PA" or IL "Customized parametrization FF" has been selected in feature 570 "Service", customer specific presettings can be selected for the following parameters:

Parameter	Communication	Selection list / range of values
Setup → Distance unit	<ul style="list-style-type: none"> ■ HART ■ PA ■ FF 	<ul style="list-style-type: none"> ■ in ■ mm
Setup → Empty calibration	<ul style="list-style-type: none"> ■ HART ■ PA ■ FF 	max. 70 m (230 ft)
Setup → Full calibration	<ul style="list-style-type: none"> ■ HART ■ PA ■ FF 	max. < 70 m (230 ft)
Setup → Adv. Setup → Current output 1/2 → Damping	HART	0 to 999.9 s
Setup → Adv. Setup → Current output 1/2 → Failure mode	HART	<ul style="list-style-type: none"> ■ Min ■ Max ■ Last valid value
Setup → Adv. Setup → Current output 1/2 → Burst mode	HART	<ul style="list-style-type: none"> ■ Off ■ On

Services



The following services can be selected via the product structure in the Product Configurator ¹⁵⁾:

- PWIS free (PWIS: paint wetting impairment substances)
- Customized parametrization HART →  96
- Customized parametrization PA →  96
- Customized parametrization FF →  96
- Without tooling DVD (FieldCare)

15) Feature 570 of the product structure

Accessories

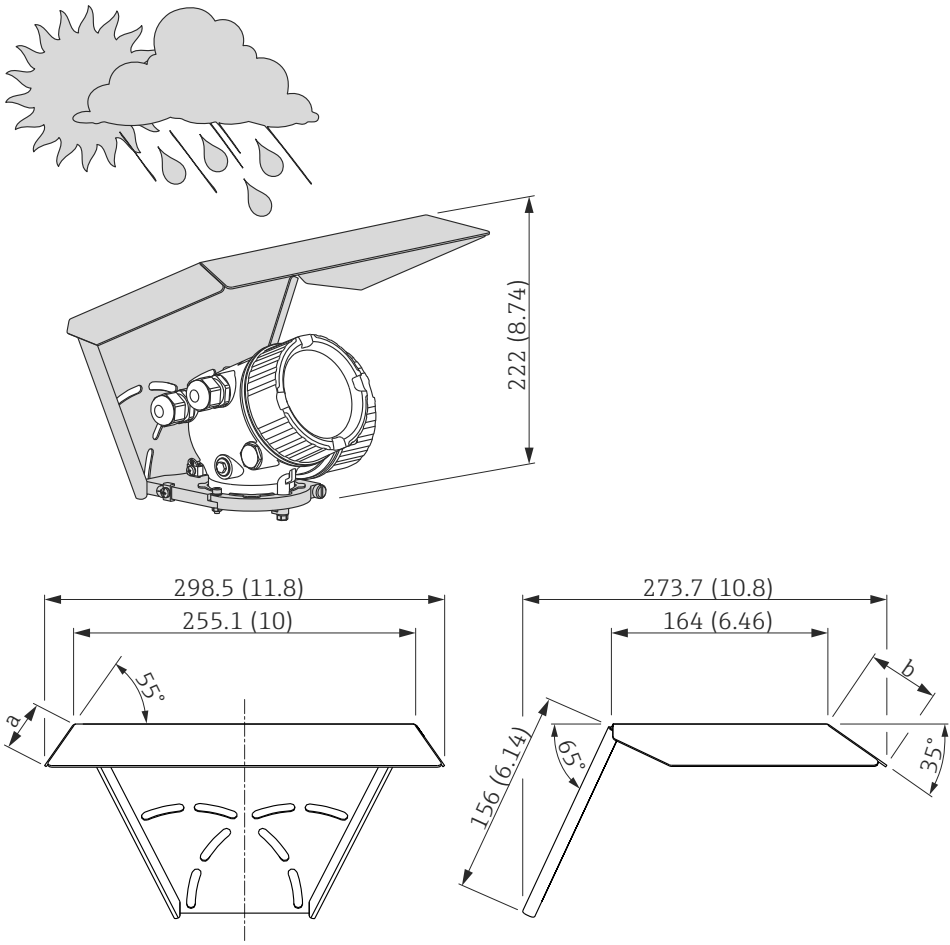

Device-specific accessories Weather protection cover

Accessory	Description
Weather protection cover	 <p data-bbox="1476 927 1528 943">A0015466</p> <p data-bbox="416 1368 925 1397">☑ 36 Weather protection cover; Dimensions: mm (in)</p> <p data-bbox="416 1408 622 1438">a 37,8 mm (1,5 in)</p> <p data-bbox="416 1438 606 1467">b 54 mm (2,1 in)</p> <p data-bbox="416 1491 1492 1572">  The weather protection cover can be ordered together with the device (product structure, feature 620 "Accessory Enclosed", option PB "Weather Protection Cover"). Alternatively, it can be separately ordered as an accessory; order code 71162242. </p> <p data-bbox="1476 1346 1528 1361">A0015472</p>

Remote display FHX50

Accessory	Description
Remote display FHX50	<div data-bbox="325 315 1203 757" style="text-align: center;"> </div> <p style="text-align: right; font-size: small;">A0019128</p> <ul style="list-style-type: none"> ▪ Material: <ul style="list-style-type: none"> – Plastics PBT – 316L ▪ Ingress protection: IP68 / NEMA 6P and IP66 / NEMA 4x ▪ Suitable for the display modules: <ul style="list-style-type: none"> – SD02 (push buttons) – SD03 (touch control) ▪ Connection cable: <ul style="list-style-type: none"> – Cable with M12 plug; supplied with the FHX50; up to 30 m (98 ft) – Customer supplied standard cable; up to 60 m (196 ft) ▪ Ambient temperature: –40 to 80 °C (–40 to 176 °F) <p> i ▪ If the remote display is to be used, the device must be ordered in the version "Prepared for display FHX50" (feature 030, option L or M). For the FHX50, on the other hand, the option A: "Prepared for display FHX50" has to be selected in feature 050: "Option Measurement Device". </p> <p> i ▪ If a device has not been ordered in the version "Prepared for display FHX50", but is nevertheless to be equipped with an FHX50, it is essential to select the option B: "Not prepared for display FHX50" in feature 050: "Option Measurement Device" of the FHX50. In this case, a retrofit kit, needed to prepare the device for the remote display, is supplied together with the FHX50. </p> <p> i For transmitters with approval, application of the FHX50 may be restricted. A device may only be retrofitted with the FHX50 if option L or M ("Prepared for FHX50") is quoted under <i>Basic specifications</i>, position 4 "Display, operation" in the associated Safety Instructions (XA). In addition to this, observe the Safety Instructions (XA) of the FHX50. </p> <p> i Do not retrofit transmitters with: <ul style="list-style-type: none"> ▪ approval for use in areas with combustible dusts (Dust-Ex approval) ▪ type of protection Ex nA </p> <p> i For details refer to the document SD01007F. </p>

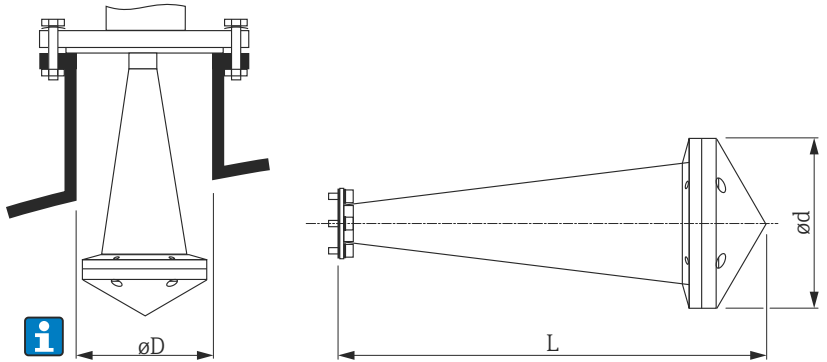
Horn protection for horn antenna

Accessory	Description
Horn protection for 80 mm (3 in) or 100 mm (4 in) horn antenna	 <p data-bbox="414 716 1005 750">For details please refer to the Mounting Instructions SD01084F.</p> <p data-bbox="414 757 598 784">Process conditions</p> <ul data-bbox="414 784 877 840" style="list-style-type: none"> Maximum vessel pressure: 0.5 bar (7.252 psi) Maximum process temperature: 130 °C (266 °F) <p data-bbox="414 851 933 907">  Danger of explosion Avoid electrostatic charging of the horn protection. </p> <p data-bbox="1476 683 1532 694">A0019143</p>

Horn protection FMR51

Antenna ¹⁾	Accessory mounted ²⁾	Order code of horn protection	Dimensions		
			Ød	L	ØD
BC: Horn 80mm/3"	<ul style="list-style-type: none"> OU: ... mm antenna extension OV: ... inch antenna extension 	71105890	96 mm (3.78 in)	203 mm (8 in)	≥ DN100
	any other version	71105890	96 mm (3.78 in)	238 mm (9.4 in)	≥ DN100
BD: Horn 100mm/4"	<ul style="list-style-type: none"> OU: ... mm antenna extension OV: ... inch antenna extension 	71105889	116 mm (4.57 in)	267 mm (10.5 in)	≥ DN150
	any other version	71105889	116 mm (4.57 in)	302 mm (11.9 in)	≥ DN150

- 1) Feature 070 of the product structure
- 2) Feature 610 of the product structure

 The horn protection can also be ordered together with the device. Product structure: Feature 610 "Accessory Mounted", option OW "Horn protection, PTFE".

Overvoltage protection

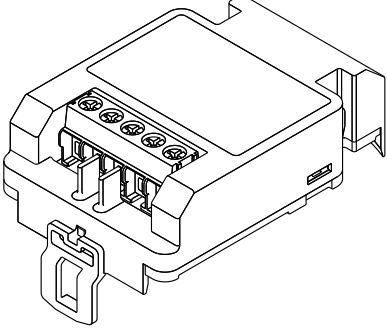
Accessory	Description
Overvoltage protection for 2-wire-devices OVP10 (1 channel) OVP20 (2 channel)	<div style="text-align: right; margin-bottom: 10px;">A0021734</div>  <p>Technical data</p> <ul style="list-style-type: none"> ▪ Resistance per channel: $2 * 0.5 \Omega_{max}$ ▪ Threshold DC voltage: 400 to 700 V ▪ Threshold impulse voltage: < 800 V ▪ Capacitance at 1 MHz: < 1.5 pF ▪ Nominal arrest impulse voltage (8/20 μs): 10 kA ▪ Suited for wire cross-sections: 0.2 to 2.5 mm² (24 to 14 AWG) <p>i Ordering with device The overvoltage protection module is preferably ordered with the device. See product structure, feature 610 "Accessory mounted", option NA "Overvoltage protection". Separate ordering of the module is only necessary if a device is to be retrofitted with the overvoltage protection.</p> <p>i Order code for retrofitting</p> <ul style="list-style-type: none"> ▪ For 1-channel devices (feature 020, option A) OVP10: 71128617 ▪ For 2-channel devices (feature 020, option B, C, E or G) OVP20 : 71128619 <p>Housing lid for retrofitting In order to keep the necessary safety distances, the housing lid needs to be replaced if the device is retrofitted with the overvoltage protection. Depending on the housing type, the order code of the suitable lid is as follows:</p> <ul style="list-style-type: none"> ▪ GT18 housing: Lid 71185516 ▪ GT19 housing: Lid 71185518 ▪ GT20 housing: Lid 71185516 <p>i Restrictions for retrofitting Depending on the approval of the transmitter the usage of the OVP module may be restricted. A device may only be retrofitted with an OVP module if the option NA (overvoltage protection) is quoted under <i>Optional Specifications</i> in the Safety Instructions (XA) pertaining to the device.</p> <p>i For details refer to SD01090F.</p>

Gas-tight feedthrough

Accessory	Description
Gas-tight feedthrough	Chemically inert glass feedthrough; prevents migration of gases into the electronics housing. To be ordered with the device: product structure, feature 610 "Accessory Mounted", option NC "Gas-tight feedthrough"

Communication-specific accessories

Accessory	Description
Commubox FXA195 HART	For intrinsically safe HART communication with FieldCare via the USB interface.  For details refer to Technical Information TI00404F

Accessory	Description
Commubox FXA291	Connects Endress+Hauser field devices with CDI interface (= Endress+Hauser Common Data Interface) to the USB interface of a computer. Order code: 51516983  For details refer to Technical Information TI00405C

Accessory	Description
HART Loop Converter HMX50	Evaluates the dynamic HART variables and converts them to analog current signals or limit values. Order code: 71063562  For details refer to Technical Information TI00429F and Operating Instructions BA00371F

Accessory	Description
WirelessHART Adapter SWA70	Connects field devices to a WirelessHART network. The WirelessHART adapter can be mounted directly at a HART device and is easily integrated into an existing HART network. It ensures safe data transmission and can be operated in parallel with other wireless networks.  For details refer to Operating Instructions BA00061S

Accessory	Description
Fieldgate FXA320	Gateway for remote monitoring of connected 4-20mA measuring devices via web browser.  For details refer to Technical Information TI00025S and Operating Instructions BA00053S

Accessory	Description
Fieldgate FXA520	Gateway for remote diagnosis and parametrization of connected HART measuring devices via web browser.  For details refer to Technical Information TI00025S and Operating Instructions BA00051S



Accessory	Description
Field Xpert SFX350	Field Xpert SFX350 is a mobile computer for commissioning and maintenance. It enables efficient device configuration and diagnostics for HART and FOUNDATION fieldbus devices in the non-Ex area .  For details, see Operating Instructions BA01202S

Accessory	Description
Field Xpert SFX370	Field Xpert SFX370 is a mobile computer for commissioning and maintenance. It enables efficient device configuration and diagnostics for HART and FOUNDATION fieldbus devices in the non-Ex area and the Ex area .  For details, see Operating Instructions BA01202S

Service-specific accessories

Accessory	Description
FieldCare	Endress+Hauser's FDT-based Plant Asset Management tool. Helps to configure and maintain all field devices of your plant. By supplying status information it also supports the diagnosis of the devices.  For details refer to Operating Instructions BA00027S and BA00059S.

System components

Accessory	Description
Graphic Data Manager Memograph M	The graphic data manager Memograph M provides information on all the relevant process variables. Measured values are recorded correctly, limit values are monitored and measuring points analyzed. The data are stored in the 256 MB internal memory and also on an SD card or USB stick.  For details refer to Technical Information TI00133R and Operating Instructions BA00247R
RN221N	Active barrier with power supply for safe separation of 4 to 20 mA current circuits. Provides bi-directional HART transmission.  For details refer to Technical Information TI00073R and Operating Instructions BA00202R
RNS221	Transmitter supply for 2-wire sensors or transmitters exclusively for non-Ex areas. Provides bi-directional communication using the HART communication sockets.  For details refer to Technical Information TI00081R and Operating Instructions KA00110R

Documentation



The following document types are available:

- On the CD supplied with the device
- In the Download Area of the Endress+Hauser Internet site: www.endress.com → Download

Standard documentation

Micropilot FMR51, FMR52

Correlation of documentations to the device:

Device	Power supply, output	Communication	Document type	Document code
FMR51 FMR52	A, B, C, K, L	HART	Operating Instructions	BA01049F/00/EN
			Brief Operating Instructions	KA01100F/00/EN
			Description of Device Parameters	GP01014F/00/EN
	G	PROFIBUS PA	Operating Instructions	BA01125F/00/EN
			Brief Operating Instructions	KA01129F/00/EN
			Description of Device Parameters	GP01018F/00/EN
	E	FOUNDATION Fieldbus	Operating Instructions	BA01121F/00/EN
			Brief Operating Instructions	KA01125F/00/EN
			Description of Device Parameters	GP01017F/00/EN

Supplementary documentation

Device	Document type	Document code
Fieldgate FXA520	Technical Information	TI369F/00/EN
Tank Side Monitor NRF590	Technical Information	TI402F/00/EN
	Operating Instructions	BA256F/00/EN
	Description of Device Parameters	BA257F/00/EN

Safety Instructions (XA)

Depending on the approval, the following Safety Instructions (XA) are supplied with the device. They are an integral part of the Operating Instructions.

Feature 010	Approval	Available for	Feature 020 "Power Supply; Output"				
			A ¹⁾	B ²⁾	C ³⁾	E ^{4)/G⁵⁾}	K ^{6)/L⁷⁾}
BA	ATEX: II 1 G Ex ia IIC T6-T1 Ga	<ul style="list-style-type: none"> ▪ FMR51 ▪ FMR52 	XA00677F	XA01224F	XA001225	XA00685F	-
BB	ATEX: II 1/2 G Ex ia IIC T6-T1 Ga/Gb	<ul style="list-style-type: none"> ▪ FMR51 ▪ FMR52 	XA00677F	XA01224F	XA001225	XA00685F	-
BC	ATEX: II 1/2 G Ex d [ia] IIC T6-T1 Ga/Gb	<ul style="list-style-type: none"> ▪ FMR51 ▪ FMR52 	XA00680F	XA00680F	XA01232F	XA00688F	XA01233F
BD	ATEX: II 1/2/3 G Ex ic [ia Ga] IIC T6-T1 Ga/Gb/Gc	<ul style="list-style-type: none"> ▪ FMR51 ▪ FMR52 	XA00678F	XA01226F	XA01227F	XA00686F	XA01228F
BG	ATEX: II 3 G Ex nA IIC T6-T1 Gc	<ul style="list-style-type: none"> ▪ FMR51 ▪ FMR52 	XA00679F	XA01229F	XA01230F	XA00687F	XA01231F
BH	ATEX: II 3 G Ex ic IIC T6-T1 Gc	<ul style="list-style-type: none"> ▪ FMR51 ▪ FMR52 	XA00679F	XA01229F	XA01230F	XA00687F	XA01231F
BL	ATEX: II 1/2/3 G Ex nA [ia Ga] IIC T6-T1 Ga/Gb/Gc	<ul style="list-style-type: none"> ▪ FMR51 ▪ FMR52 	XA00678F	XA01226F	XA01227F	XA00686F	XA01228F
B2	ATEX: II 1/2 G Ex ia IIC T6-T1 Ga/Gb ATEX: II 1/2 D Ex ia IIIC Txx°C Da/Db	<ul style="list-style-type: none"> ▪ FMR51 ▪ FMR52 	XA00683F	XA00683F	XA01235F	XA00691F	-

Feature 010	Approval	Available for	Feature 020 "Power Supply; Output"				
			A ¹⁾	B ²⁾	C ³⁾	E ⁴⁾ /G ⁵⁾	K ⁶⁾ /L ⁷⁾
B3	ATEX: II 1/2 G Ex d [ia] IIC T6-T1 Ga/Gb ATEX: II 1/2 D Ex ta IIIC Txx°C Da/Db	■ FMR51 ■ FMR52	XA00684F	XA00684F	XA00684F	XA00692F	XA01236F
B4	ATEX:II 1/2 G Ex ia IIC T6-T1 Ga/Gb ATEX: II 1/2 G Ex d [ia] IIC T6-T1 Ga/Gb	■ FMR51 ■ FMR52	XA00681F	XA00681F	XA01234F	XA00689F	-
CD	CSA C/US DIP Cl.II,III Div.1 Gr.E-G	FMR51	XA01113F	XA01113F	XA01113F	XA01115F	XA01113F
C2	CSA C/US IS Cl.I,II,III Div.1 Gr.A-G, NI Cl.1 Div.2, Ex ia	■ FMR51 ■ FMR52	XA01112F	XA01112F	XA01112F	XA01114F	-
C3	CSA C/US XP Cl.I,II,III Div.1 Gr.A-G, NI Cl.1 Div.2, Ex d	■ FMR51 ■ FMR52	XA01113F	XA01113F	XA01113F	XA01115F	XA01113F
FB	FM IS Cl.I,II,III Div.1 Gr.A-G, AEx ia, NI Cl.1 Div.2	■ FMR51 ■ FMR52	XA01116F	XA01116F	XA01116F	XA01118F	-
FD	FM XP Cl.I,II,III Div.1 Gr.A-G, AEx d, NI Cl.1 Div.2	■ FMR51 ■ FMR52	XA01117F	XA01117F	XA01117F	XA01119F	XA01117F
FE	FM DIP Cl.II,III Div.1 Gr.E-G	FMR51	XA01117F	XA01117F	XA01117F	XA01119F	XA01117F
IA	IECEX: Ex ia IIC T6-T1 Ga	■ FMR51 ■ FMR52	XA00677F	XA01224F	XA001225	XA00685F	-
IB	IECEX: Ex ia IIC T6-T1 Ga/Gb	■ FMR51 ■ FMR52	XA00677F	XA01224F	XA001225	XA00685F	-
IC	IECEX: Ex d [ia] IIC T6-T1 Ga/Gb	■ FMR51 ■ FMR52	XA00680F	XA00680F	XA01232F	XA00688F	XA01233F
ID	IECEX: Ex ic [ia Ga] IIC T6-T1 Ga/Gb/Gc	■ FMR51 ■ FMR52	XA00678F	XA01226F	XA01227F	XA00686F	XA01228F
IG	IECEX: Ex nA IIC T6-T1 Gc	■ FMR51 ■ FMR52	XA00679F	XA01229F	XA01230F	XA00687F	XA01231F
IH	IECEX: Ex ic IIC T6-T1 Gc	■ FMR51 ■ FMR52	XA00679F	XA01229F	XA01230F	XA00687F	XA01231F
IL	IECEX: Ex nA [ia Ga] IIC T6-T1 Ga/Gb/Gc	■ FMR51 ■ FMR52	XA00678F	XA01226F	XA01227F	XA00686F	XA01228F
I2	IECEX: Ex ia IIC T6-T1 Ga/Gb IECEX: Ex ia IIIC Txx°C Da/Db	■ FMR51 ■ FMR52	XA00683F	XA00683F	XA01235F	XA00691F	-
I3	IECEX: Ex d [ia] IIC T6-T1 Ga/Gb IECEX: Ex ta IIIC Txx°C Da/Db	■ FMR51 ■ FMR52	XA00684F	XA00684F	XA00684F	XA00692F	XA01236F
I4	IECEX: Ex ia IIC T6-T1 Ga/Gb IECEX: Ex d [ia] IIC T6-T1 Ga/Gb	■ FMR51 ■ FMR52	XA00681F	XA00681F	XA01234F	XA00689F	-
KA	KC Ex ia IIC T6 Ga	■ FMR51 ■ FMR52	XA01045F	XA01045F	XA01045F	XA01047F	-
KB	KC Ex ia IIC T6 Ga/Gb	■ FMR51 ■ FMR52	XA01045F	XA01045F	XA01045F	XA01047F	-
KC	KC Ex d[ia] IIC T6	■ FMR51 ■ FMR52	XA01046F	XA01046F	XA01046F	XA01048F	XA01046F
MA	INMETRO: Ex ia IIC T6 Ga	■ FMR51 ■ FMR52	XA01286F	XA01287F	XA01288F	XA01296F	-
MC	INMETRO: Ex d[ia] IIC T6 Ga/Gb	■ FMR51 ■ FMR52	XA01292F	XA01292F	XA01293F	XA01298F	XA01294F
MH	INMETRO: Ex ic IIC T6 Gc	■ FMR51 ■ FMR52	XA01289F	XA01290F	XA01291F	XA01297F	-
NA	NEPSI Ex ia IIC T6 Ga	■ FMR51 ■ FMR52	XA01199F	XA01199F	XA01199F	XA01208F	-
NB	NEPSI Ex ia IIC T6 Ga/Gb	■ FMR51 ■ FMR52	XA01199F	XA01199F	XA01199F	XA01208F	-

Feature 010	Approval	Available for	Feature 020 "Power Supply; Output"				
			A ¹⁾	B ²⁾	C ³⁾	E ^{4)/G⁵⁾}	K ^{6)/L⁷⁾}
NC	NEPSI Ex d[ia] IIC T6 Ga/Gb	<ul style="list-style-type: none"> ▪ FMR51 ▪ FMR52 	XA01202F	XA01202F	XA01202F	XA01211F	XA01202F
NG	NEPSI Ex nA II T6 Gc	<ul style="list-style-type: none"> ▪ FMR51 ▪ FMR52 	XA01201F	XA01201F	XA01201F	XA01210F	XA01201F
NH	NEPSI Ex ic IIC T6 Gc	<ul style="list-style-type: none"> ▪ FMR51 ▪ FMR52 	XA01201F	XA01201F	XA01201F	XA01210F	XA01201F
N2	NEPSI Ex ia IIC T6 Ga/Gb, Ex iaD 20/21 T85...90oC	<ul style="list-style-type: none"> ▪ FMR51 ▪ FMR52 	XA01205F	XA01205F	XA01205F	XA01214F	-
N3	NEPSI Ex d[ia] IIC T6 Ga/Gb, DIP A20/21 T85...90oC IP66	<ul style="list-style-type: none"> ▪ FMR51 ▪ FMR52 	XA01206F	XA01206F	XA01206F	XA01215F	XA01206F
8A	FM/CSA IS+XP Cl.I,II,III Div.1 Gr.A-G	<ul style="list-style-type: none"> ▪ FMR51 ▪ FMR52 	<ul style="list-style-type: none"> ▪ XA01112F ▪ XA01113F ▪ XA01116F ▪ XA01117F 	<ul style="list-style-type: none"> ▪ XA01112F ▪ XA01113F ▪ XA01116F ▪ XA01117F 	<ul style="list-style-type: none"> ▪ XA01112F ▪ XA01113F ▪ XA01116F ▪ XA01117F 	<ul style="list-style-type: none"> ▪ XA01114F ▪ XA01115F ▪ XA01118F ▪ XA01119F 	-

- 1) 2-wire; 4-20mA HART
- 2) 2-wire; 4-20mA HART, switch output
- 3) 2-wire; 4-20mA HART, 4-20mA
- 4) 2-wire; FOUNDATION Fieldbus, switch output
- 5) 2-wire; PROFIBUS PA, switch output
- 6) 4-wire 90-253VAC; 4-20mA HART
- 7) 4-wire 10.4-48VDC; 4-20mA HART

 For certified devices the relevant Safety Instructions (XA) are indicated on the nameplate.

If the device is prepared for the remote display FHX50 (product structure: feature 030: Display, Operation", option L or M), the Ex marking of some certificates changes according to the following table ¹⁶⁾:

Feature 010 ("Approval")	Feature 030 ("Display, Operation")	Ex marking
BE	L or M	ATEX II 1D Ex ta [ia] IIIC T ₅₀₀ xx°C Da
BF	L or M	ATEX II 1/2 D Ex ta [ia Db] IIIC Txx°C Da/Db
BG	L or M	ATEX II 3G Ex nA [ia Ga] IIC T6 Gc
BH	L or M	ATEX II 3G Ex ic [ia Ga] IIC T6 Gc
B3	L or M	ATEX II 1/2G Ex d [ia] IIC T6 Ga/Gb, ATEX II 1/2D Ex ta [ia Db] IIIC Txx°C Da/Db
IE	L or M	IECEX Ex ta [ia] IIIC T500 xx°C Da
IF	L or M	IECEX ta [ia Db] IIIC Txx°C Da/Db
IG	L or M	IECEX Ex nA [ia Ga] IIC T6 Gc
IH	L or M	IECEX Ex ic [ia Ga] IIC T6 Gc
I3	L or M	IECEX Ex d [ia] IIC T6 Ga/Gb, IECEX Ex ta [ia Db] IIIC Txx°C Da/Db
MH	L or M	Ex ic [ia Ga] IIC T6 Gc
NG	L or M	NEPSI Ex nA [ia Ga] IIC T6-T1 Gc
NH	L or M	NEPSI Ex ic [ia Ga] IIC T6-T1 Gc
N3	L or M	NEPSI Ex d [ia] IIC T6-T1 Ga/Gb, DIP A20/21 [ia D] TA, Txx°C IP6X

16) The marking of certificates not mentioned in this table are not affected by the FHX50.

Registered trademarks

HART®

Registered trademark of the HART Communication Foundation, Austin, USA

PROFIBUS®

Registered trademark of the PROFIBUS User Organization, Karlsruhe, Germany

FOUNDATION™ Fieldbus

Registered trademark of the Fieldbus Foundation, Austin, Texas, USA

KALREZ®, VITON®

Registered trademark of DuPont Performance Elastomers L.L.C., Wilmington, USA

TEFLON®

Registered trademark of E.I. DuPont de Nemours & Co., Wilmington, USA

TRI CLAMP®

Registered trademark of Alfa Laval Inc., Kenosha, USA

Patents

This product may be protected by at least one of the following patents.

Further patents are pending.

US Patents	EP Patents
5.948.979	882 957
6.087.978	955 527
6.140.940	-
6.155.112	834 722
-	882 955
6.266.022	1 083 413
6.295.874	210 567
6.512.358	1 301 914
6.606.904	-
6.640.628	-
6.679.115	1 360 523
-	1 389 337
6.779.397	-
7.201.050	-
7.412.337	-
7.552.634	-
7.730.760	-
7.819.002	-
-	1 774 616
7.966.141	-
8.040.274	-
8.049.371	-



71282556

www.addresses.endress.com
