

Type 846 and Model 3311 Electro-Pneumatic Transducers

The Type 846 and Model 3311 electro-pneumatic transducers (figure 1) are rugged, field-mountable transducers that accept an electrical input signal and converts it to a pneumatic output signal. Typically, the 4 to 20 mA is converted to 0.2 to 1.0 bar (3 to 15 psi). In the most common application, the transducer converts an electrical output signal from a controller to a pneumatic signal necessary to operate a control valve actuator or pneumatic positioner.

The transducer includes a patented deflector/nozzle design (figure 2) that consists of two nozzles positioned so that the constant air flow exiting the supply nozzle is directed at the entrance of the receiver nozzle. Each nozzle has a large bore of 0.41 mm (0.016 inches), which provides good resistance to plugging. The input current signal positions a deflector bar within the nozzle's flow

stream. As the input signal changes, the deflector bar moves to alter the flow stream to the receiver nozzle, establishing a pilot pressure at the receiver nozzle. The pilot pressure, in turn, controls the booster stage and output of the transducer.

An electronic feedback control network constantly compares the value of the pneumatic output signal with the input current signal. A solid-state pressure sensor is part of the electronics package monitoring the pneumatic output (figure 4). A comparator circuit in the control network detects input-output deviations and adjusts the output by moving the deflector in the pilot stage to a corrected position. Because of this feedback network, the transducer can correct for error-producing effects such as variations in supply pressure and downstream leakage.



**TYPE 846 AND MODEL 3311
ELECTRO-PNEUMATIC TRANSDUCER**



**TYPE 846 AND MODEL 311
MOUNTED ON TYPE 667 ACTUATOR**

Figure 1. Type 846 and Model 3311 Electro-Pneumatic Transducers



Specifications

Input Signal⁽¹⁾

4-20 mA dc, field adjustable split ranging.

Equivalent Circuit

See figure 5

Output Signal⁽¹⁾

Standard Performance: ■ 0.2 to 1.0 bar (3 to 15 psi). Rangeability between 0.1 to 1.2 bar (1 and 18 psi).

Multirange Performance: ■ 0 to 1.2 bar (0 to 18 psi), ■ 0.4 to 2.0 bar (6 to 30 psi), and ■ 0 to 2.3 bar (0 to 33 psi) nominal ranges. Actual rangeability available between 0.03 to 2.3 bar (0.5 and 33 psi).

Action: ■ Direct (increasing input signal increases transducer output) (Minimum span, 6 psi) or ■ Reverse (increasing input signal decreases transducer output) (Minimum span, 11 psi)

Supply Pressure⁽¹⁾

Standard Performance: 1.2 to 1.6 bar (18 to 24 psi)

Multirange Performance:

Minimum: 0.2 bar (3 psi) [0.14 bar (2 psi) for a 2.3 bar (33 psi) output] greater than the maximum calibrated output pressure.

Maximum: 2.4 bar (35 psi)

Medium: Air or natural gas⁽⁴⁾

Steady-State Air Consumption⁽¹⁾⁽²⁾

0.3 normal m³/hr (0.20 scfm) at 1.4 bar (20 psi) supply pressure.

Output Air Capacity⁽²⁾

Standard Performance: 6.7 normal m³/hr (4.0 scfm) at 1.4 bar (20 psi) supply pressure.

Multirange Performance: 9.0 normal m³/hr (6.0 scfm) at 2.5 bar (35 psi) supply pressure

Temperature Limits

Operating:⁽¹⁾ -40 to 85°C (-40 to 185°F).

Storage:⁽¹⁾ -40 to 93°C (-40 to 200°F).

Humidity Limits

0-100% condensing relative humidity.

Performance⁽³⁾

Linearity⁽¹⁾, Hysteresis⁽¹⁾, and Repeatability: ±0.3% of span.

Temperature Effect (total effect including zero and span): ±0.07%/°C (0.045%/°F) of span

Vibration Effect: ±0.3% of span per g during the following conditions:

5-15 Hz at 4 mm constant displacement

15-150 Hz at 2 g. 150-2000 Hz at 1 g.

per SAMA Standard PMC 31.1-1980, Sec. 5.3, Condition 3, Steady State.

Shock Effect: ±0.5% of span, when tested per SAMA Standard PMC 31.1, Sec. 5.4.

Supply Pressure Effect: Negligible

Electromagnetic Interference (EMI): Tested per IEC 61326-1 (Edition 1.1). Meets emission levels for Class A equipment (industrial locations) and Class B equipment (domestic locations). Meets immunity requirements for industrial locations (Table A.1). Immunity performance is shown in table 1.

Leak Sensitivity:⁽²⁾ Less than 1.0% of span for up to 5.0 normal m³/hr (3.0 scfm) downstream leakage.

Overpressure Effect: Less than 0.25% of span for misapplication of up to 7.0 bar (100 psi) supply pressure for less than 5 minutes to the input port.

Reverse Polarity Protection: No damage occurs from reversal of normal supply current (4-20 mA) or from misapplication of up to 100 mA.

Connections

Supply and Output Pressure: 1/4-18 NPT female connection.

Electrical: 1/2-14 NPT female conduit connection.

Adjustments

Zero and Span: Screwdriver adjustments located in terminal compartment.

Remote Pressure Reading (optional)

ON or OFF; jumper selectable

Frequency Range: 5,000-8,000 Hz.

Amplitude: 0.4-1.0 V_{p-p}

- Continued -

Specifications (Continued)

<p>Required Operating Voltage</p> <p>Min. 6.0 V (at 4 mA) Max. 7.2 V (at 20 mA) with Remote Pressure Reading ON Min. 6.4 V (at 4 mA) Max. 8.2 V (at 20 mA)</p> <p>Electrical Classification</p> <p>Hazardous area: Explosion proof, dust ignition proof, intrinsically safe, and non-incendive constructions available. Refer to the Hazardous Area Classification Bulletin 9.2:002.</p> <p>Electrical Housing: NEMA 4X, CSA Enclosure Type 4X, IP66 per IEC60529, Tropicalization (Fungus test per MIL-STD-810)</p>	<p>Construction Materials</p> <p>Housing: ■ Low-copper aluminum with polyurethane paint, or ■ 316 stainless steel O-Rings: Buna-N, except silicone for sensor O-rings.</p> <p>Mounting</p> <p>■ Actuator, ■ pipestand, or ■ surface</p> <p>Weight</p> <p>Aluminum: 2.9 kg (6.5 lb) excluding options Stainless Steel: 6.7 kg (14.8 lb) excluding options</p> <p>Options</p> <p>■ Type 67AFR filter regulator, ■ supply and output gauges, ■ remote pressure reading, or ■ stainless steel mounting bracket</p>
---	--

1. Defined in ISA Standard S51.1.
2. Normal m³/hr: normal cubic meters per hour (m³/hr, 0°C and 1.01325 bar, absolute). Scfm: standard cubic feet per minute (ft³/min, 60°F and 14.7 psig).
3. Performance values are obtained using a transducer with a 4 to 20 mA dc input signal, a 3 to 15 psig output, and 20 psig supply pressure.
4. This product is approved for use with Natural Gas. Refer to the Hazardous Area Classification Bulletin 9.2:002. Natural gas to contain no more than 20 ppm of H₂S.

Table 1. Immunity Performance

Port	Phenomenon	Basic Standard	Performance Criteria ⁽¹⁾
Enclosure	Electrostatic discharge (ESD)	IEC 61000-4-2	A
	Radiated EM field	IEC 61000-4-3	A
	Rated power frequency magnetic field	IEC 61000-4-8	A
I/O signal/control	Burst (fast transients)	IEC 61000-4-4	A
	Surge	IEC 61000-4-5	B
	Conducted RF	IEC 61000-4-6	B
Specification limit = ±1% of span 1. A = No degradation during testing. B = Temporary degradation during testing, but is self-recovering.			

Type 846 and Model 3311 Transducers

Features

- **Vibration Resistant**—The low-mass pilot stage, mechanically damped deflector bar, and rugged construction provide stable performance in vibration.
- **Tolerant of Dirty Supply Air**—Large diameter nozzles, free-flow pilot stage design and large internal air passages provide excellent tolerance to dirty air by reducing the effects of contaminant buildup and erosion.
- **Increased Accuracy, Reduced Sensitivity to Supply Pressure Variations and Downstream Leakage**—The electronic feedback control network monitors the pneumatic output signal, detects any input-output deviations and corrects them. This provides very high accuracy and allows the transducer to sense changes in the final element condition and rapidly optimize its air delivery.
- **Easy Maintenance**—Major mechanical and electrical components are incorporated into a single field-replaceable “master module” (figure 3). The transducer does not have to be removed from its mounting to facilitate troubleshooting or service. A separate field wiring compartment eases installation and maintenance.



W6287 / IL

Figure 2. Detail of Deflector/Nozzle Pilot Stage

- **Quick Diagnostic Checks and Remote Performance Monitoring**—With *Stroke Port*, a constant bleed from the pilot stage vents through a hole in the module cover. Covering the hole increases the transducer output to confirm the proper operation of the pilot and booster stages and stroke the actuator. With optional *Remote Pressure Reading*, a frequency directly proportional to the output pressure is superimposed on the input signal wires.

Using a Field Communicator or frequency counter, an operator can monitor the Type 846 and Model 3311 output pressure.

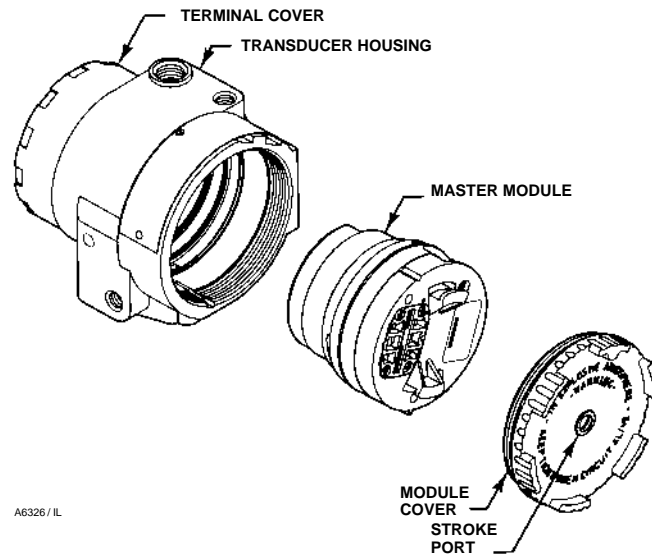

A6326 / IL

Figure 3. Master Module Construction

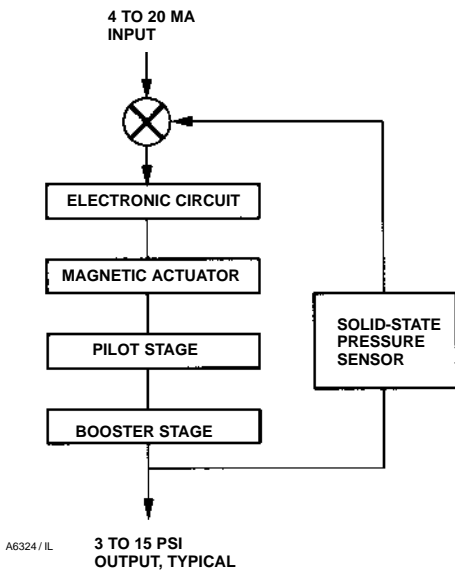

A6324 / IL

Figure 4. Functional Block Diagram

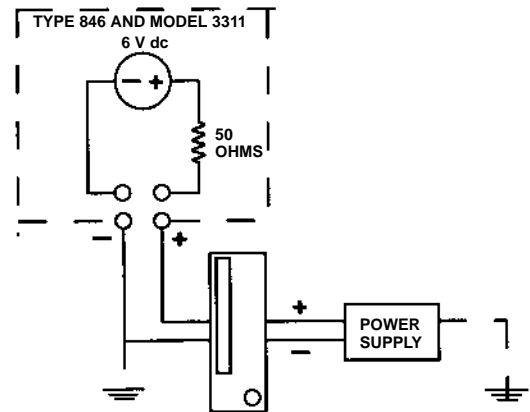

NOTE:
THE TYPE 846 AND MODEL 3311 ARE NOT CONSTANT RESISTORS IN SERIES WITH AN INDUCTOR. IT IS BETTER MODELED IN THE LOOP AS A 50 OHM RESISTOR IN SERIES WITH A 6-VOLT DC VOLTAGE DROP WITH NEGLIGIBLE INDUCTANCE.

A6325 / IL

Figure 5. Equivalent Circuit

Type 846 and Model 3311 Transducers

Product Bulletin

62.1:846

September 2003

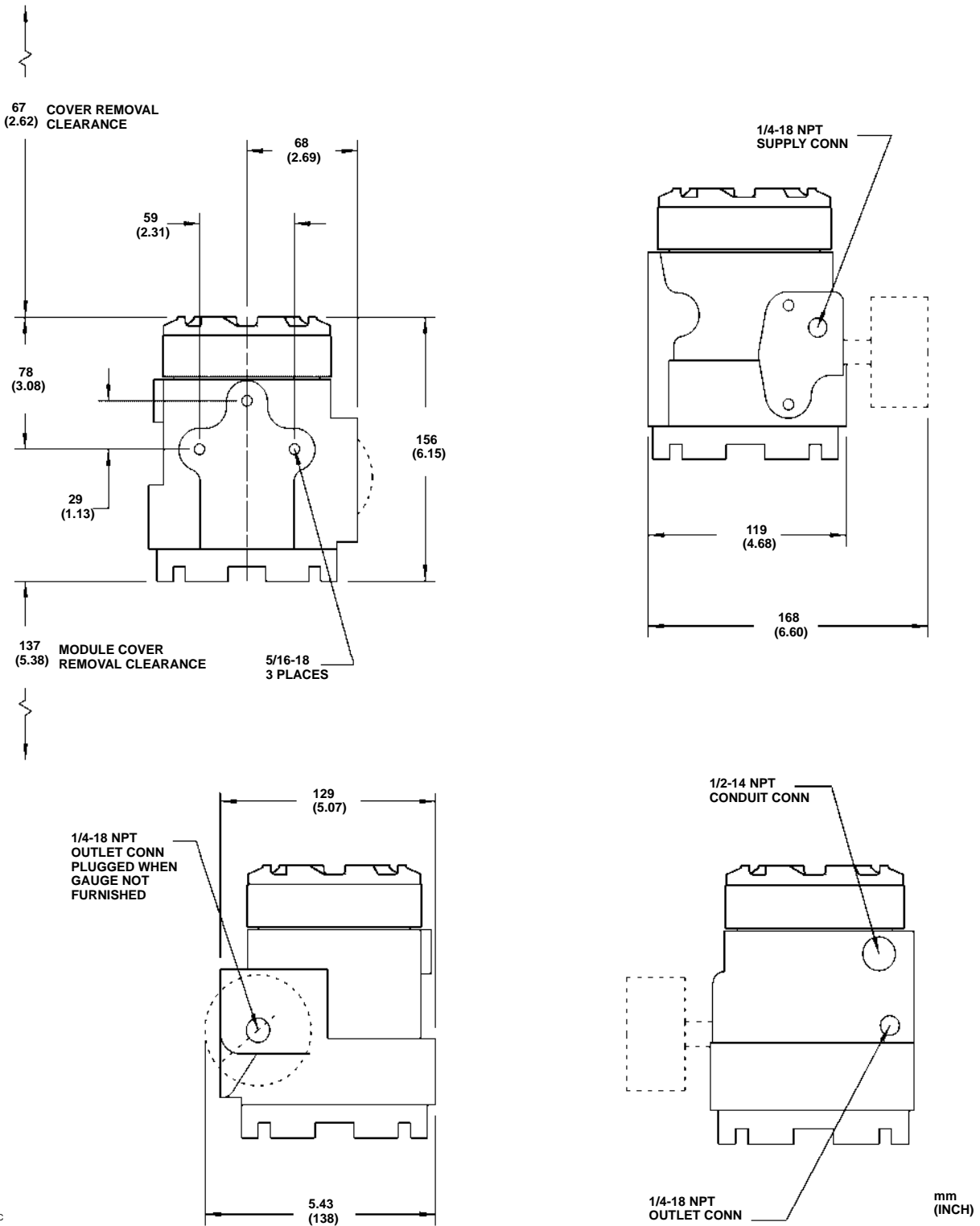
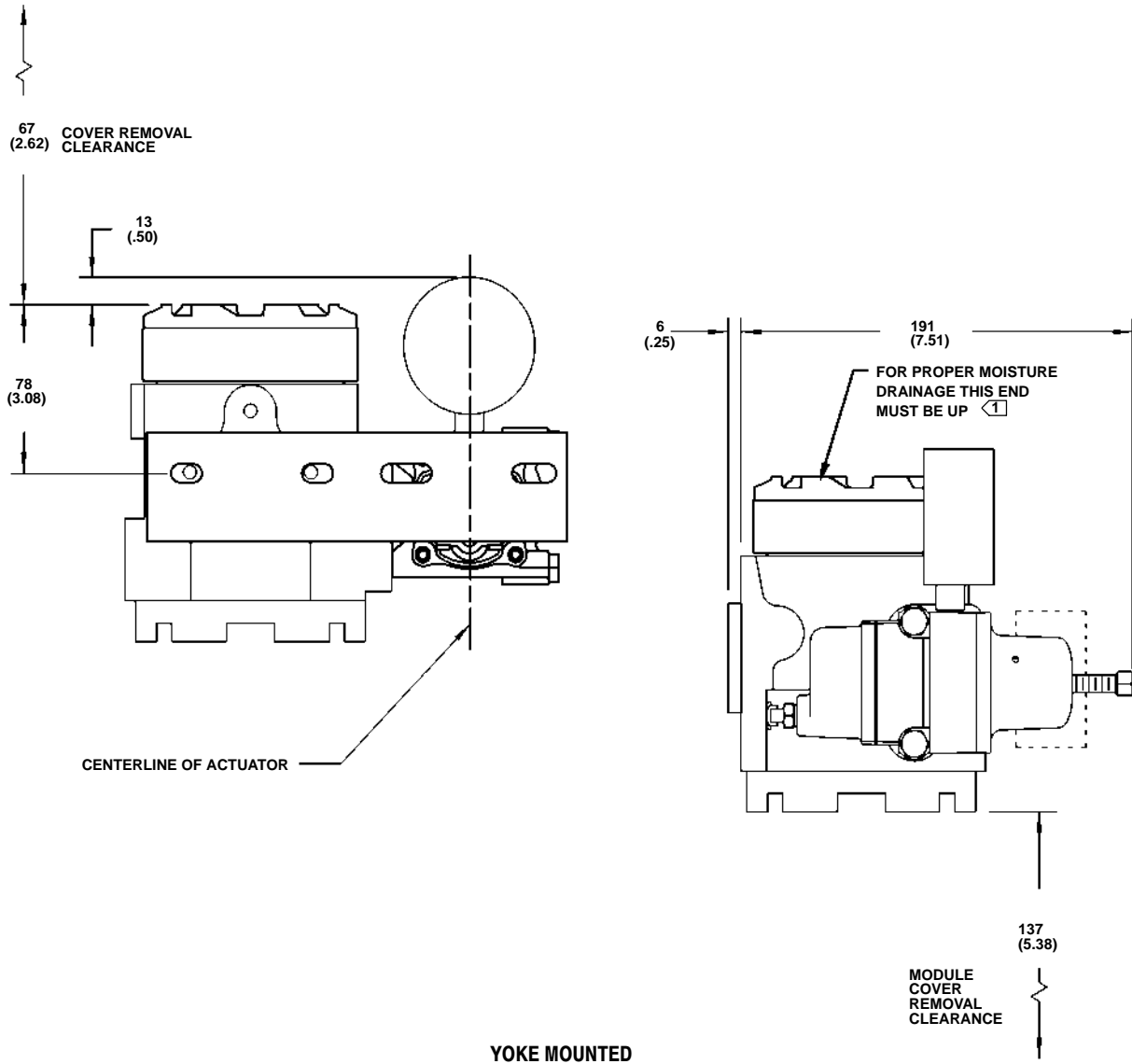

Figure 6. Dimensions

14B7364-C



NOTE:

1 THE MOUNTING POSITIONS SHOWN ALLOW ANY MOISTURE BUILDUP IN THE TERMINAL COMPARTMENT TO DRAIN TO THE SIGNAL WIRE CONDUIT ENTRANCE. DO NOT MOUNT THE TRANSDUCER WITH THE TERMINAL COMPARTMENT COVER ON THE BOTTOM; MOISTURE MAY ACCUMULATE IN THE TERMINAL COMPARTMENT OR PILOT STAGE, PREVENTING PROPER TRANSDUCER OPERATION. THE VERTICAL MOUNT IS MOST EFFECTIVE FOR MOISTURE DRAINAGE IN WET APPLICATIONS.

mm
(INCH)

14B7361-D

Figure 7. Dimensions with Optional 67 Filter-Regulator (Yoke Mounted)

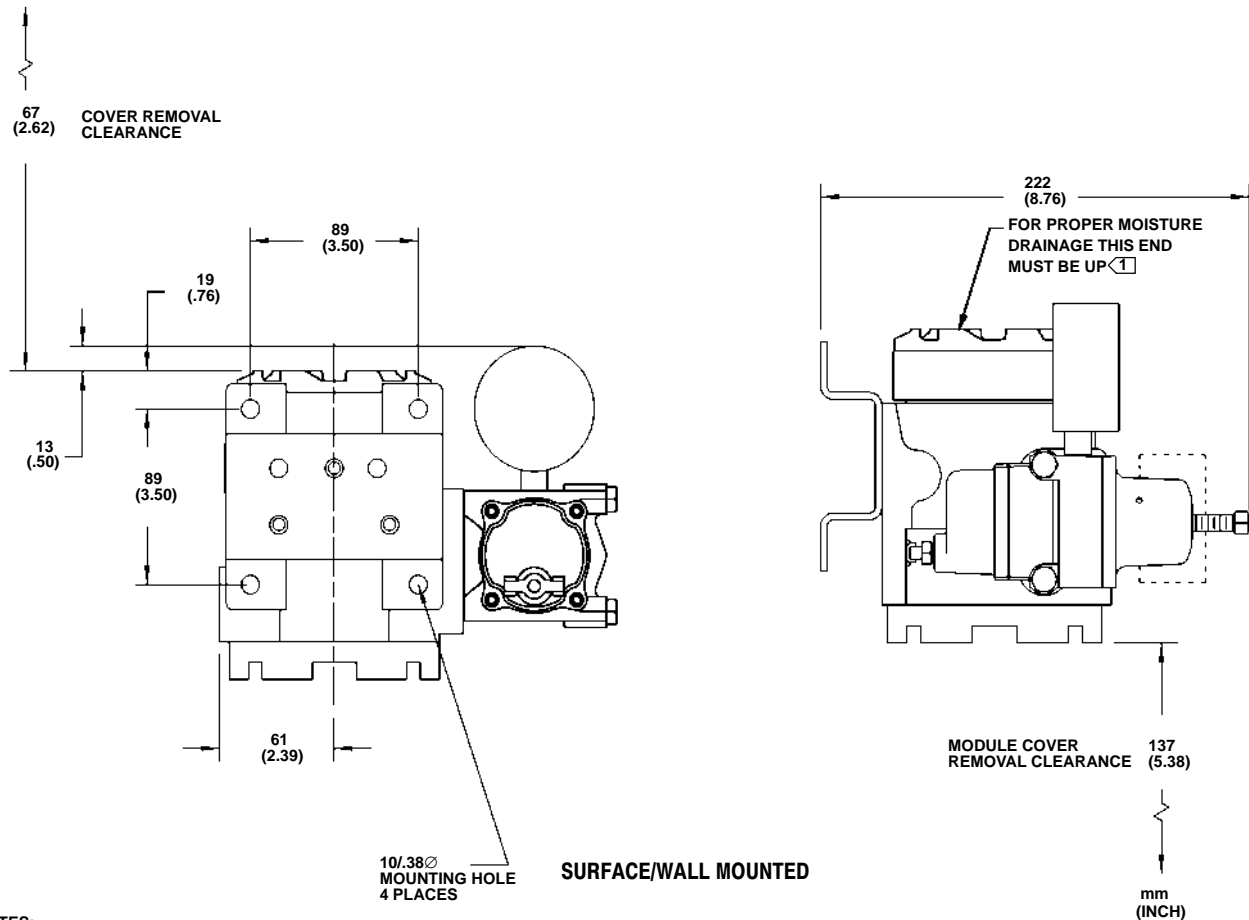

NOTES:

[1] THE MOUNTING POSITIONS SHOWN ALLOW ANY MOISTURE BUILDUP IN THE TERMINAL COMPARTMENT TO DRAIN TO THE SIGNAL WIRE CONDUIT ENTRANCE. DO NOT MOUNT THE TRANSDUCER WITH THE TERMINAL COMPARTMENT COVER ON THE BOTTOM; MOISTURE MAY ACCUMULATE IN THE TERMINAL COMPARTMENT OR PILOT STAGE, PREVENTING PROPER TRANSDUCER OPERATION. THE VERTICAL MOUNT IS MOST EFFECTIVE FOR MOISTURE DRAINAGE IN WET APPLICATIONS.

14B7332-D

Figure 8. Dimensions with Optional 67 Filter-Regulator (Surface/Wall Mounted)

Installation

The transducer may be actuator, wall, panel, or pipestand mounted. Dimensions are shown in figures 7, 8, and 9.

To determine what ordering information is required, refer to the specification table. Carefully review the description of each specification. Specify the desired choice whenever there is a selection available.

Ordering Information

Note: Fisher does not assume responsibility for the selection, use, or maintenance of any product. Responsibility for proper selection, use, and maintenance of any Fisher product remains solely with the purchaser and end user.

When ordering mounting parts, specify actuator, surface, or pipestand mounting. For actuator mounting, specify the actuator type, size, travel, and diaphragm pressure range. For all Type 657 and 667 actuators except size 80, specify whether actuator yoke or actuator casing mounting is desired (yoke mounting only is available on size 80 actuators).

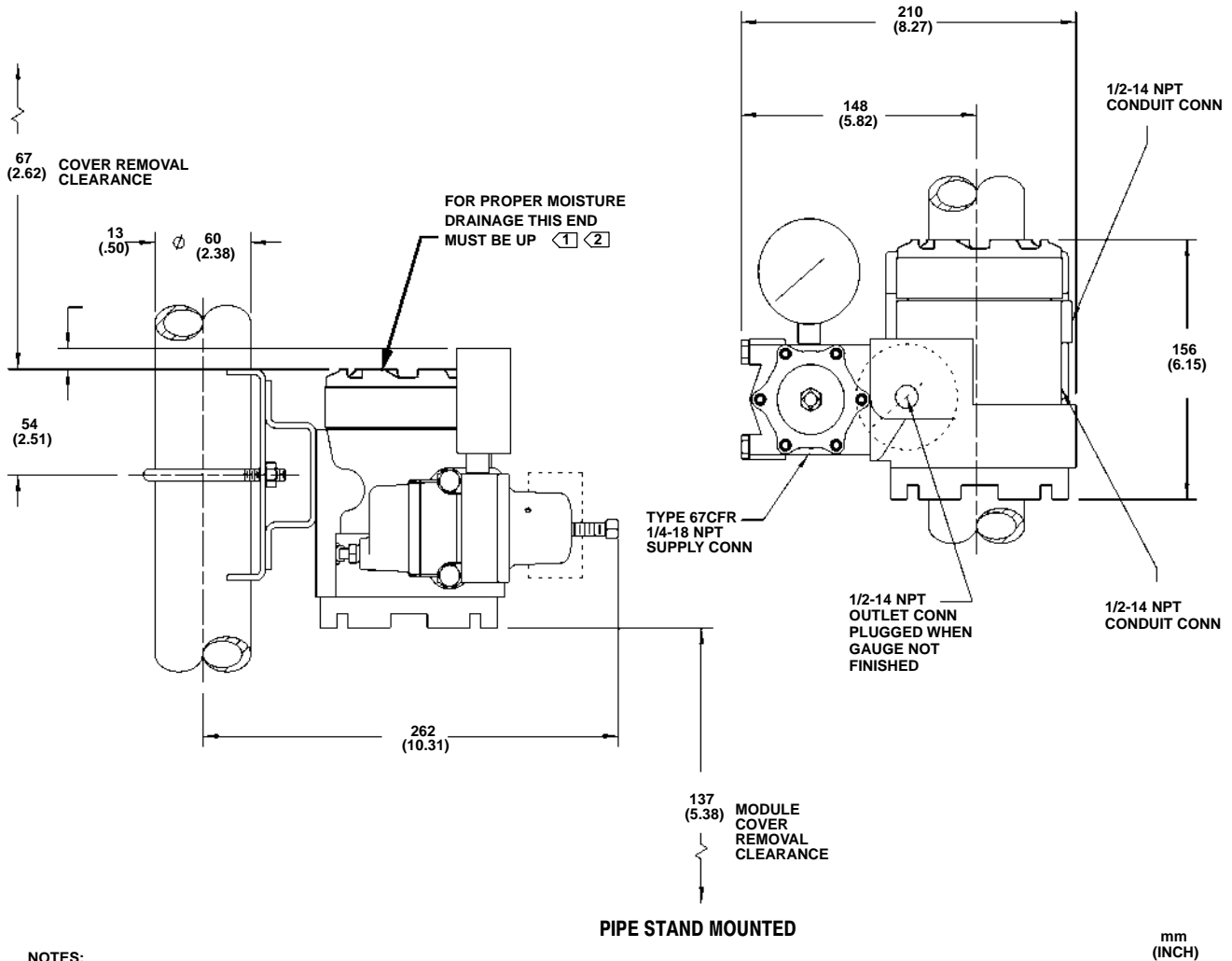

NOTES:

- 1 THE MOUNTING POSITIONS SHOWN ALLOW ANY MOISTURE BUILDUP IN THE TERMINAL COMPARTMENT TO DRAIN TO THE SIGNAL WIRE CONDUIT ENTRANCE. DO NOT MOUNT THE TRANSDUCER WITH THE TERMINAL COMPARTMENT COVER ON THE BOTTOM; MOISTURE MAY ACCUMULATE IN THE TERMINAL COMPARTMENT OR PILOT STAGE, PREVENTING PROPER TRANSDUCER OPERATION. THE VERTICAL MOUNT IS MOST EFFECTIVE FOR MOISTURE DRAINAGE IN WET APPLICATIONS.
- 2 IF MOUNTED ON HORIZONTAL PIPE, THE I/P MUST BE ON TOP OF THE PIPE FOR PROPER MOISTURE DRAINAGE.

14B7363-D

Figure 9. Dimensions with Optional 67 Filter-Regulator (Pipe Stand Mounted)

mm
(INCH)

Type 846 and Model 3311 Transducers

Product Bulletin

62.1:846

September 2003

Fisher is a mark owned by Fisher Controls International LLC, a business of Emerson Process Management. The Emerson logo is a trademark and service mark of Emerson Electric Co. All other marks are the property of their respective owners. This product may be covered by one or more of the following patents (4,481,967; 4,534,376; 4,638,830; 4,653,523; 4,665,938; 4,760,859; 4,777,826; 4,901,756) or under pending patent applications.

The contents of this publication are presented for informational purposes only, and while every effort has been made to ensure their accuracy, they are not to be construed as warranties or guarantees, express or implied, regarding the products or services described herein or their use or applicability. We reserve the right to modify or improve the designs or specifications of such products at any time without notice.

Fisher does not assume responsibility for the selection, use or maintenance of any product. Responsibility for proper selection, use and maintenance of any Fisher product remains solely with the purchaser and end-user.

Emerson Process Management

Fisher

Marshalltown, Iowa 50158 USA

Cernay 68700 France

Sao Paulo 05424 Brazil

Singapore 128461

www.Fisher.com

