

# Vortex Flow Measuring System *PROline prowirl 72*

## Reliable Flow Measurement of Gas, Steam and Liquids



### Application

For measuring the volume flow of steam, gases and liquids.

For utility and process applications in the chemical, petrochemical, power and district heating industries and in many other industries.

### Your benefits

- Proven capacitive sensor (installed base > 100,000)
- Immune to:
  - Vibration (over 1 g in all axes)
  - Temperature shock (> 150 K/s)
  - Dirty media
  - Water hammer
- Process temp. range -330° to +750°F (-200° to +400°C)
- Universal:
  - Compact or remote version
  - Dualsens version, with two sensors and electronics (for redundancy)
  - Alloy C-22 version
- Connection to all common systems:
  - HART
  - PROFIBUS-PA
  - FOUNDATION Fieldbus
- Galvanically isolated pulse output available (for alarm, limit value etc.).
- Permanent self-monitoring and diagnosis of electronics and sensor.
- Correction of diameter mismatch.
- No maintenance, no moving parts, no zero-point drift.

Endress + Hauser

The Power of Know How



## Function and system design

### Measuring principle

The operating principle is based on the Karman vortex street. When a fluid flows past a bluff body, vortices are alternately formed on the sides of that body and are then detached or shed by the flow. The frequency of vortex shedding is proportional to the mean flow velocity and, therefore, to the volumetric flow. Alternating pressure changes caused by the vortices are transmitted by the sensor. The DSC sensor is located behind the bluff body and is well protected from water hammer and temperature or pressure shocks.

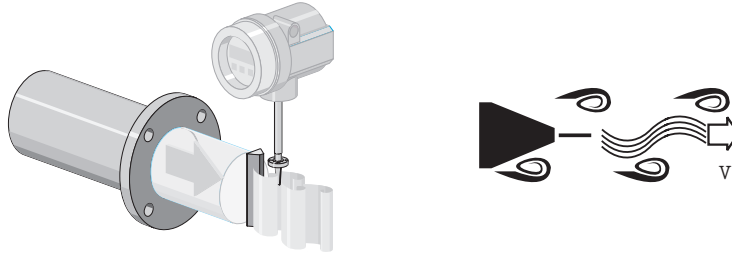

The K-factor is used as the proportional constant:

$$\text{K-Factor} = \frac{\text{pulses}}{\text{unit volume [gal]}} \quad \text{OR} \quad \text{K-Factor} = \frac{\text{pulses}}{\text{unit volume [dm}^3\text{]}}$$

Within the application limits of the device, the K-factor only depends on the geometry of the device. It is independent of the fluid velocity and its properties viscosity and density. In this way, the K-factor is also independent of the type of fluid to be measured, regardless of whether this is steam, a gas or a liquid.

The primary measuring signal is already digital (frequency signal) and a linear function of the flow. After manufacturing the meter, the K-factor is determined in the factory by means of calibration and is not subjected to any long term drift or zero point shift.

The device does not contain any moving parts and requires no maintenance.

### The capacitive sensor

The sensor of a vortex flowmeter has a major influence on the performance, robustness and reliability of the whole measuring system.

The Prowirl 72 uses Endress + Hauser's proven and patented capacitive measuring technology, with more than 100,000 Vortex measuring points installed to date world wide.

Due to its internal mechanical balance, the DSC sensor (Differential Switched Capacitance), reads only the pressure pulses caused by the vortices and stays immune to any influence from mechanical pipe line vibrations.

The DSC sensor measures low flow rates at low fluid density even when pipe line vibrations are present. Therefore, the Prowirl 72 keeps its wide turndown ratio even under rough operating conditions.

Vibrations of at least 1g at frequencies up to 500 Hz in all axes do not affect the flow measurement.

Thanks to its mechanical design, the capacitive sensor is especially resistant to temperature shocks and water hammer in steam lines.

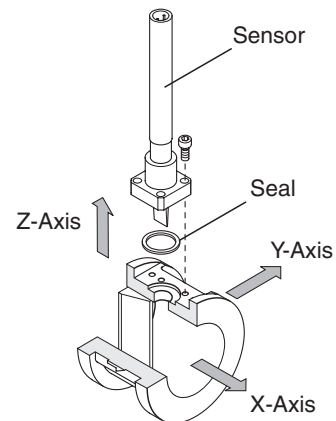

**Measuring system**

The measuring system consist of a sensor and a transmitter.

Two versions are available:

- Compact version: sensor and transmitter form a mechanical unit.
- Remote version: sensor is mounted separate from the transmitter.

Sensor

- Prowirl F 1/2" to 12" (DN 15 to 300)  
Flanged version (also available as version with two sensors and electronics for redundancy, 1-1/2" to 6" / DN 40 to 150)
- Prowirl W 1/2" to 6" (DN 15 to 150)  
Wafer version

Transmitter

- Prowirl 72

**Input****Measured variable**

Volumetric flow (volume flow), is proportional to the frequency of vortex shedding after the bluff body.

The output variables are volume flow or, if the process conditions are non-varying, calculated mass flow or corrected volume flow.

**Measuring range**

The measuring range depends on the fluid and the nominal diameter.

**Start of measuring range**

Depends on the density and the Reynolds number ( $Re_{min} = 4,000$ ,  $Re_{linear} = 20,000$ ).

The Reynolds number is dimensionless and indicates the ratio of a fluid's inertial forces to its viscous forces. It is used to characterize the flow. The Reynolds number is calculated as follows:

$$Re = \frac{4 \cdot Q [\text{ft}^3/\text{s}] \cdot \rho [\text{lb}/\text{ft}^3]}{\pi \cdot di [\text{ft}] \cdot \mu [0.001 \text{ cP}]} \quad Re = \frac{4 \cdot Q [\text{m}^3/\text{s}] \cdot \rho [\text{kg}/\text{m}^3]}{\pi \cdot di [\text{m}] \cdot \mu [\text{Pa} \cdot \text{s}]}$$

$Re$  = Reynolds number;  $Q$  = Flow;  $di$  = Internal diameter;  $\mu$  = Dynamic viscosity;  $\rho$  = Density

$$1/2'' \text{ to } 1'' \rightarrow v_{min.} = \frac{4.92}{\sqrt{\rho [\text{lb}/\text{ft}^3]}} [\text{ft}/\text{s}] \quad 1-1/2'' \text{ to } 6'' \rightarrow v_{min.} = \frac{5.74}{\sqrt{\rho [\text{lb}/\text{ft}^3]}} [\text{ft}/\text{s}]$$

$$\text{DN } 15 \text{ to } 25 \rightarrow v_{min.} = \frac{6}{\sqrt{\rho [\text{kg}/\text{m}^3]}} [\text{m}/\text{s}] \quad \text{DN } 40 \text{ to } 300 \rightarrow v_{min.} = \frac{7}{\sqrt{\rho [\text{kg}/\text{m}^3]}} [\text{m}/\text{s}]$$

**Full scale value**

- Gas/steam:  $v_{max} = 248 \text{ ft/s}$  (75 m/s), for 1/2"  $v_{max} = 152 \text{ ft/s}$  (DN 15:  $v_{max} = 46 \text{ m/s}$ )
- Liquids:  $v_{max} = 30 \text{ ft/s}$  (9 m/s)

Note!

By using the selection and sizing software "Applicator", you can determine the exact values for the fluid you use. The Applicator is available from your Endress+Hauser sales center or on the Internet at [www.endress.com](http://www.endress.com).

**Measuring range for gases ft<sup>3</sup>/hr or SCFH [m<sup>3</sup>/h or Nm<sup>3</sup>/h]**

In the case of gases, the start of the measuring range depends on the density. With ideal gases, the density  $[\rho]$  or corrected density  $\rho_S [\rho_N]$  can be calculated using the following formula:

$$\rho [\text{lb}/\text{ft}^3] = \frac{\rho_S [\text{lb}/\text{SCF}] \cdot P [\text{psia}] \cdot 530 [^\circ\text{R}]}{T [^\circ\text{F} + 460] \cdot 14.7 [\text{psia}]} \quad \rho_S [\text{lb}/\text{SCF}] = \frac{\rho [\text{lb}/\text{ft}^3] \cdot T [^\circ\text{F} + 460] \cdot 14.7 [\text{psia}]}{P [\text{psia}] \cdot 530 [^\circ\text{R}]}$$

$$\rho [\text{kg}/\text{m}^3] = \frac{\rho_N [\text{kg}/\text{Nm}^3] \cdot P [\text{bar abs}] \cdot 273.15 [\text{K}]}{T [\text{K}] \cdot 1.013 [\text{bar abs}]} \quad \rho_N [\text{kg}/\text{Nm}^3] = \frac{\rho [\text{kg}/\text{m}^3] \cdot T [\text{K}] \cdot 1.013 [\text{bar abs}]}{P [\text{bar abs}] \cdot 273.15 [\text{K}]}$$

The following formula can be used to calculate the volume [Q] or corrected volume  $Q_S$  [ $Q_N$ ] in the case of ideal gases:

$$Q \text{ [ft}^3\text{/h]} = \frac{Q_S \text{ [SCF/h]} \cdot T \text{ [}^\circ\text{F} + 460] \cdot 14.7 \text{ [psia]}}{P \text{ [psia]} \cdot 530 \text{ [}^\circ\text{R]}}$$

$$Q_S \text{ [SCF/h]} = \frac{Q \text{ [ft}^3\text{/h]} \cdot P \text{ [psia]} \cdot 530 \text{ [}^\circ\text{R]}}{T \text{ [}^\circ\text{F} + 460] \cdot 14.7 \text{ [psia]}}$$

$$Q \text{ [m}^3\text{/h]} = \frac{Q_N \text{ [Nm}^3\text{/h]} \cdot T \text{ [K]} \cdot 1.013 \text{ [bar abs]}}{P \text{ [bar abs]} \cdot 273.15 \text{ [K]}}$$

$$Q_N \text{ [Nm}^3\text{/h]} = \frac{Q \text{ [m}^3\text{/h]} \cdot P \text{ [bar abs]} \cdot 273.15 \text{ [K]}}{T \text{ [K]} \cdot 1.013 \text{ [bar abs]}}$$

$T$  = Operating temperature;  $P$  = Operating pressure

## Output

### Output signal

- Current output:  
4 to 20 mA with HART, Full scale value and time constant (0 to 100 s) can be set  
Temperature coefficient: typically 0.003% o.r./ °F (0.005% o.r. / °C)  
(o.r. = of reading)
- Pulse/status output:  
Open collector, passive,  
Galvanically isolated,  
Nonhazardous, Ex proof:  $U_{\max} = 36 \text{ V}$ , with 15 mA current limit,  $R_i = 500 \Omega$   
Intrinsically safe:  $U_{\max} = 30 \text{ V}$ , with 15 mA current limit,  $R_i = 500 \Omega$   
Can be configured as:
  - Pulse output:  
Pulse value and polarity can be selected (5 to 2000 ms),  
Pulse frequency max. 100 Hz
  - Status output:  
Can be configured for error messages or flow limit values
  - Vortex frequency:  
Direct output of unscaled vortex pulses 0.5 to 2850 Hz (pulse ratio 1:1).
  - PFM signal (pulse-frequency modulation):  
By connecting the pulse and current output.

### PROFIBUS-PA interface:

- PROFIBUS-PA in accordance with EN 50170 Volume 2, IEC 61158-2 (MBP), galvanically isolated
- Current consumption = 16 mA
- FDE (Fault Disconnection Electronic) = 0 mA
- Data transmission rate: Supported baudrate = 31.25 kBit/s
- Signal encoding = Manchester II
- Function blocks: 1 x Analog Input, 1 x Totalizer
- Output data: Volume flow, Calculated mass flow, Corrected volume flow, Totalizer
- Input data: Empty pipe detection (ON/OFF), Control totalizer
- Bus address adjustable via DIP-switches at the measuring device

### FOUNDATION Fieldbus interface:

- FOUNDATION Fieldbus H1, IEC 61158-2, galvanically isolated
- Current consumption = 16 mA
- Signal encoding = Manchester II
- FDE (Fault Disconnection Electronic) = 0 mA
- Data transmission rate: Supported baudrate = 31.25 kBit/s
- Function blocks: 2 x Analog Input, 1 x Discrete Output
- Output data: Volume flow, calculated Mass flow, corrected Volume flow, Totalizer
- Input data: Empty pipe detection (ON/OFF), Reset totalizer
- Link Master (LM) functionality is supported

**Signal on alarm**

- Current output: error response can be selected (e.g. in accordance with NAMUR Recommendation NE 43)
- Pulse output: error response can be selected
- Status output: "not conducting" in event of fault

**Load**

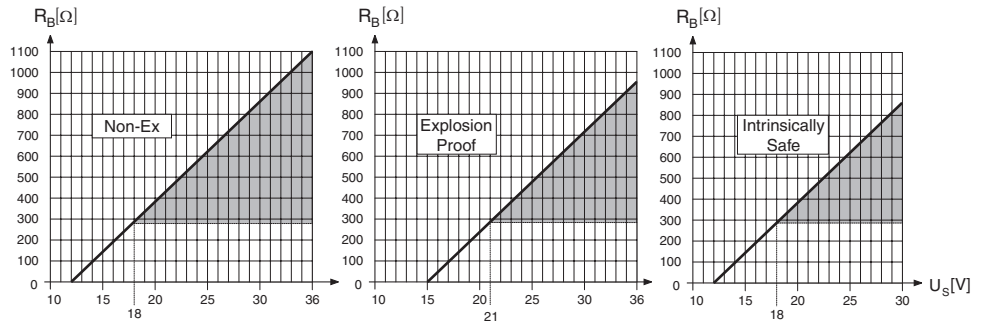

The grey shaded area indicates the permissible load (for HART: min. 250  $\Omega$ )  
 The load can be calculated as follows:

$$R_B = \frac{(U_S - U_{Kl})}{(I_{max} \cdot 10^{-3})} = \frac{(U_S - U_{Kl})}{0.022}$$

- $R_B$  Load
- $U_S$  Supply voltage: Nonhazardous = 12 to 36 V DC; Ex proof = 15 to 36 V DC; Intrins safe = 12 to 30 V DC
- $U_{Kl}$  Terminal voltage: Nonhazardous = min. 12 V DC; Ex proof = min. 15 V DC; Intrins safe = min. 12 V DC
- $I_{max}$  Output current (22.6 mA)

**Low flow cut off**

Switch points for low flow cut off can be selected as required

**Galvanic isolation**

The electrical connections are galvanically isolated from one another.

**Power supply**

**Electrical connection**

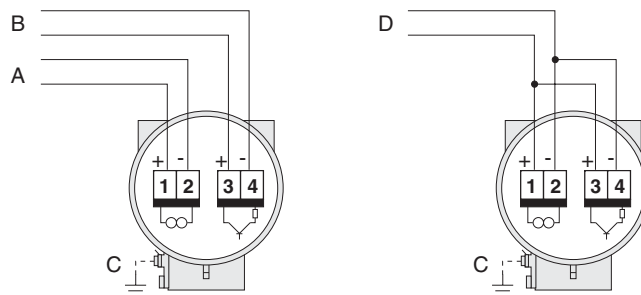

Electrical connection Prowirl 72

- A - HART: Power supply, current output  
 - PROFIBUS-PA: 1 = PA+, 2 = PA-  
 - FOUNDATION Fieldbus: 1 = FF+, 2 = FF-
- B Optional pulse output, can also be operated as status output (except PROFIBUS-PA and FOUNDATION Fieldbus)
- C Ground terminal (relevant for remote version)
- D PFM wiring (pulse-frequency modulation)

**Supply voltage**

Nonhazardous: 12 to 36 V DC (with HART 18 to 36 V DC)  
 Intrinsically safe: 12 to 30 V DC (with HART 18 to 30 V DC)  
 Explosion proof: 15 to 36 V DC (with HART 21 to 36 V DC)

PROFIBUS-PA and FOUNDATION Fieldbus  
 Nonhazardous: 9 to 32 V DC  
 Intrinsically safe: 9 to 24 V DC  
 Explosion proof: 9 to 32 V DC  
 Current consumption → PROFIBUS-PA: 16 mA, FOUNDATION Fieldbus: 16 mA

**Cable entry**

Power supply and signal cables (outputs):

- Cable entry M20 x 1.5 (8 to 11.5 mm)
- Thread for cable entry: ½" NPT, G ½" (not for remote version)
- Fieldbus connector

**Power supply failure**

- Totalizer stops at the last value determined (can be configured)
- All settings are kept in the EEPROM
- Error messages (incl. value of operated hours counter) are stored

**Performance characteristics**

**Reference operating conditions**

Error limits following ISO/DIN 11631:  
 60° to 86°F (20 to 30°C), 30 to 60 psi (2 to 4 bar), Calibration rig traceable to national standards  
 Calibration with the corresponding process connection of the respective norms

**Maximum measured error**

- Liquid:
  - < 0.75% o.r. for Re > 20,000
  - < 0.75% o.f.s for Re between 4000 to 20,000
- Gas/steam:
  - < 1% o.r. for Re > 20,000
  - < 1% o.f.s for Re between 4000 to 20,000

o.r. = Of reading, o.f.s = Of full scale, Re = Reynolds number

**Repeatability**

±0.25% o.r. (of reading)

**Operating conditions: installation**

**Installation instructions**

Vortex meters require a fully developed flow profile as a prerequisite for correct volume flow measurement. For this reason, please note the following points when installing the device:

**Orientation**

The device can generally be installed in any position in the piping.  
 In the case of liquids, upward flow is preferred in vertical pipes to avoid partial pipe filling (see orientation A).  
 In the case of hot fluids (e.g. steam or fluid temperature ≥ 390°F / 200 °C), select orientation C or D so that the permitted ambient temperature of the electronics is not exceeded. Orientations B and D are recommended for very cold fluid (e.g. liquid nitrogen).  
 Orientations B, C and D are possible with horizontal installation. The arrow indicated on the device must always point in the direction of flow in all mounting orientations.

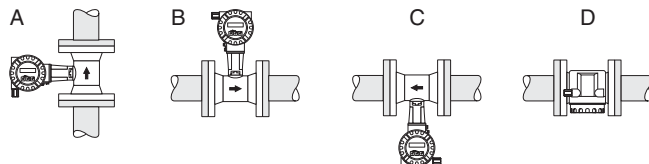

**Caution!**

- If fluid temperature is  $\geq 390^{\circ}\text{F}$  ( $200^{\circ}\text{C}$ ), orientation B is not permitted for the wafer version (Prowirl 72 W) with a nominal diameter of 4" and 6" (DN 100 and DN 150).
- In case of vertical orientation and downward flowing liquid, the piping has always to be completely filled.

**Minimum spacing and cable length**

We recommend you observe the following dimensions to guarantee problem-free access to the device for service purposes:

- Minimum spacing in all directions,  $A = 3.94''$  (100 mm)
- Necessary cable length  $L + 6''$  (150 mm)  
Allowing cable slack permits unplugging the electronics from the pipe stand without disconnecting the wiring

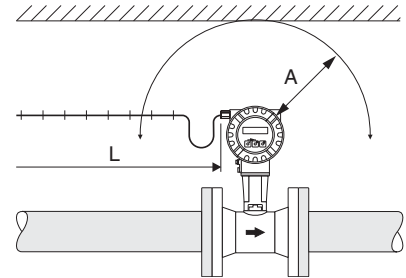
**Rotating the electronics housing and the display**

The electronics housing can be rotated continuously  $360^{\circ}$  on the housing support. The display unit can be rotated in  $45^{\circ}$  steps, allows viewing the display regardless of mounting position.

**Piping insulation**

When insulating, please ensure that a sufficiently large area of the housing support is exposed. The uncovered part serves as a radiator and protects the electronics from overheating (or undercooling).

The maximum insulation height permitted is illustrated in the diagrams. These apply equally to both the compact version and the sensor in the remote version.

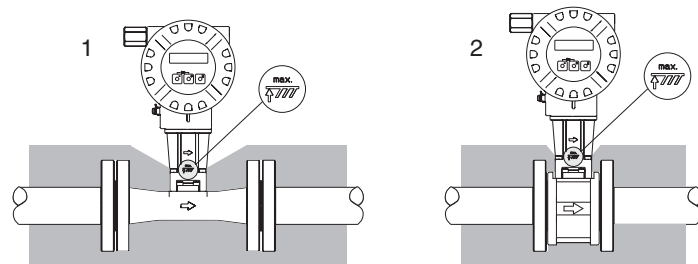

1 = Flanged version

2 = Wafer version

**Wafer version mounting set**

The centering rings supplied with the wafer style meters are used to mount and center the instrument. A mounting set consisting of tie rods, seals, nuts and washers can be ordered separately.

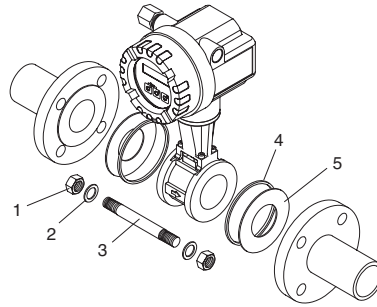

*Mounting wafer version*

- 1 = Nut
- 2 = Washer
- 3 = Tie rod
- 4 = Centering ring (supplied with the device)
- 5 = Seal

**Inlet and outlet run**

As a minimum, the inlet and outlet runs shown below must be observed to achieve the specified accuracy of the device. The longest inlet run shown must be observed if two or more flow disturbances are present. D = Pipe diameter.

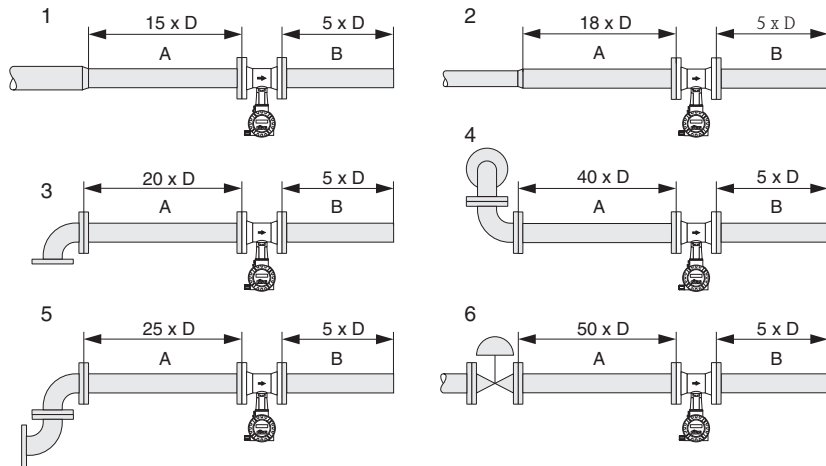

*Minimum inlet and outlet runs with various flow obstructions*

- A = Inlet run
- B = Outlet run
- 1 = Reduction
- 2 = Expansion
- 3 = 90° elbow or T-piece
- 4 = 2 x 90° elbow, 3-dimensional
- 5 = 2 x 90° elbow
- 6 = Control valve

Note!

A specially designed perforated plate flow conditioner can be installed if it is not possible to observe the inlet runs required (see Page 9).



### Outlet runs with pressure and temperature measuring points

If pressure and temperature measuring points are installed after the device, please ensure there is a large enough distance between the device and the measuring point so there are no negative effects on the vortex shedding.

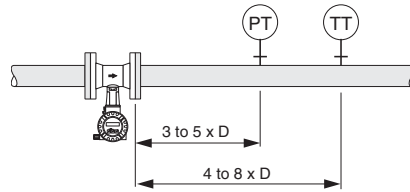

PT = Pressure measuring point

TT = Temperature measuring point

### Perforated plate flow conditioner

A specially designed perforated plate flow conditioner, available from Endress+Hauser, can be installed if it is not possible to observe the inlet runs required. The flow conditioner is fitted between two piping flanges and centered with mounting bolts. Generally, this reduces the inlet run required to 10 x D with complete accuracy.

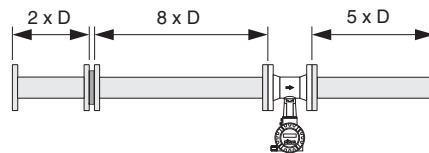

Flow conditioner

The pressure loss for flow conditioners is calculated as follows:

$$\Delta p \text{ [psi]} = 1.83 \cdot 10^{-4} \cdot \rho \text{ [lb/ft}^3\text{]} \cdot v^2 \text{ [f/s]}$$

Examples of pressure loss for flow conditioner

- Example with steam
  - $p = 145 \text{ psi}$
  - $t = 464^\circ\text{F} \rightarrow \rho = 0.27 \text{ lb/ft}^3$
  - $v = 131 \text{ ft/s}$
  - $\Delta p = 0.000183 \cdot 0.27 \cdot 131^2 = 0.86 \text{ psi}$
- Example with H<sub>2</sub>O condensate (176°F)
  - $\rho = 60 \text{ lb/ft}^3$
  - $v = 8.2 \text{ ft/s}$
  - $\Delta p = 0.000183 \cdot 60 \cdot 8.2^2 = 0.74 \text{ psi}$

## Operating conditions: environment

### Ambient temperature range

- Compact version: -40 to +158°F (-40 to +70°C)  
(EEx-d version: -40 to +140°F / -40 to +60°C; ATEX II 1/2 GD-version/dust ignition-proof: -4 to +131°F / -20 to +55°C)  
Display can be read between -4 to +158°F (-20 to +70°C)
- Remote version:
  - Sensor -40 to +185°F (-40 to +85°C)  
(ATEX II 1/2 GD-version/dust ignition-proof: -4 to +131°F / -20 to +55°C)
  - Transmitter -40 to +176°F (-40 to +80°C)  
(EEx-d version: -40 to +140°F / -40 to +60°C; ATEX II 1/2 GD-version/dust ignition-proof: -4 to +131°F / -20 to +55°C)
  - Display can be read between -4 to +158°F (-20 to +70°C)

When mounting outside, protect from direct sunlight with a protective cover (order number 543199), especially in warmer climates with high ambient temperatures.

**Storage temperature** -40 to +176°F (-40 to +80°C)  
 (ATEX II 1/2 GD-version/dust ignition-proof: -4 to +131°F / -20 to +55°C)

**Degree of protection** NEMA 4X (IP 67) according to EN 60529

**Vibration resistance** Acceleration up to 1 g, 10 to 500 Hz, following IEC 60068-2-6

**Electromagnetic compatibility (EMC)** According to EN 61326/A1 and NAMUR Recommendation NE 21.

## Operating conditions: process

**Medium temperature range**

- DSC sensor (differential switched capacitor) capacitive sensor:
 

DSC standard sensor	-40 to +500°F (-40 to +260°C)
DSC high/low temperature sensor	-330 to +750°F (-200 to +400°C)
DSC sensor Inconel (PN 64 to 160, Class 600, JIS 40K and Dualsens version)	-330 to +750°F (-200 to +400°C)
DSC sensor Alloy C-22	-330 to +750°F (-200 to +400°C)
- Seal:
 

Graphite	-330 to +750°F (-200 to +400°C)
Viton	5 to 345°F (-15 to +175°C)
Kalrez	-4 to +525°F (-20 to +275°C)
Gylon (PTFE)	-330 to +500°F (-200 to +260°C)

**Medium pressure** **Pressure-temperature curve according to ANSI B16.5, stainless steel**

ANSI B16.5:  
 Class 150 to 300 → Prowirl 72 W and 72 F  
 Class 600 → Prowirl 72 F

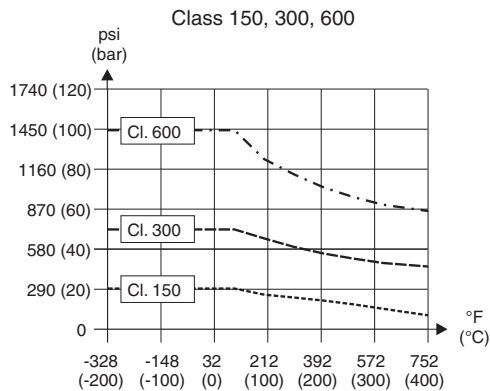

**Pressure-temperature curve according to ANSI B16.5, Alloy C-22**

Class 150 to 300, → Prowirl 72 F

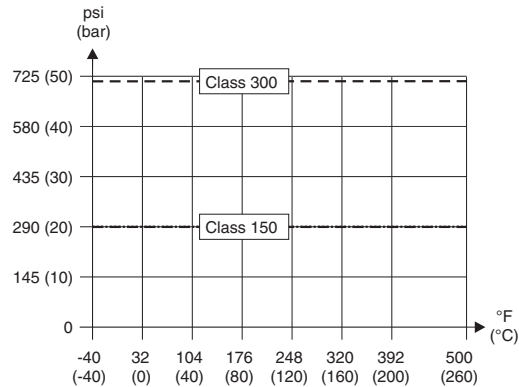

**Pressure loss**

The pressure loss can be determined with the aid of the Applicator, a software for selection and sizing of flowmeters. The software is available both via Internet ([www.applicator.com](http://www.applicator.com)) and on a CD-ROM for local PC installation.

**Measuring ranges**

The Prowirl 72 flowmeter determines the volumetric flow under operating conditions (ACFM), i.e. the effective volume at a particular operating pressure (e.g. 100 psig). Gas volumes are highly dependent on pressure and temperature. Gas quantities are, therefore, usually given at standard temperature and pressure (SCFM at 14.7 psia and 60°F), and steam quantities in pounds.

The following tables are given as a guideline for measuring ranges for a typical gas (air at 60°F and 14.7 psia) and a typical liquid (water at 70°F). Normally, the flowmeter is linear up to the maximum flow. Values down to the minimum are not always linear. Endress+Hauser will be pleased to help you select and dimension a flowmeter for your specific application.

Prowirl 72 W (Wafer Version)							
Size	SCFM Air at 14.7 psia / 60°F			GPM Water at 70°F			K-Factor Pulses/dm <sup>3</sup>
	Min	Max	F Range (Hz)	Min	Max	F Range (Hz)	
0.5"	2.35	20.6	330 - 2600	0.84	30.8	10 - 520	245 - 280
1"	6.47	94.2	180 - 2300	1.76	83.7	5.7 - 300	48 - 55
1.5"	18.2	221	140 - 1650	4.8	198	4.6 - 200	14 - 17
2"	29.4	359	100 - 1200	7.93	321	3.3 - 150	6 - 8
3"	65.9	806	75 - 850	17.6	722	2.2 - 110	1.9 - 2.4
4"	112	1371	70 - 800	30.4	1228	2 - 100	1.1 - 1.4
6"	252	3066	38 - 450	67.8	2752	1.2 - 55	0.27 - 0.32

Prowirl 72 F (Flanged Version)							
Size	SCFM Air at 14.7 psia / 60°F			GPM Water at 70°F			K-Factor Pulses/dm <sup>3</sup>
	Min	Max	F Range (Hz)	Min	Max	F Range (Hz)	
0.5"	1.77	14.1	380 - 2850	0.70	22	14 - 600	390 - 450
1"	5.30	73.6	200 - 2700	1.41	66	6.5 - 340	70 - 85
1.5"	14.7	182	150 - 1750	3.96	163	4.5 - 220	18 - 22
2"	24.7	300	120 - 1350	6.6	273	3.7 - 170	8 - 11
3"	55.9	677	80 - 900	15.0	616	2.5 - 115	2.5 - 3.2
4"	97.1	1177	60 - 700	26.4	1056	1.9 - 86	1.1 - 1.4
6"	220	2672	40 - 460	57	2422	1.2 - 57	0.3 - 0.4
8"	420	5126	27 - 322	114	4623	1.0 - 39	0.1266 - 0.1400
10"	663	8087	23 - 272	181	7265	0.8 - 33	0.0677 - 0.0748
12"	952	11,595	18 - 209	255	10,391	0.6 - 25	0.0364 - 0.0402

Saturated steam flow minimum and maximum rates by meter size are shown below. The diagram serves as a guideline for a quick estimation of measuring ranges.

NOTE: min./max. ranges below are in lbs/hr

Measuring Ranges for Prowirl 72 W Meter Sizes

Dia. (in)		psig 10	20	30	40	50	60	80	100	150	200	250	300	350
0.5	min	9.9	11.6	13.0	14.3	15.5	16.6	18.6	20.3	24.2	27.4	30.4	33.1	33.5
	max	54.5	74.9	95.0	114.8	134.4	153.9	192.6	230.9	326	420.6	515.3	610.4	706
1	min	26.1	30.6	34.4	37.9	41	43.8	49	53.7	63.8	72.5	80.6	91.6	102.1
	max	321	442	560	677	793	907.9	1136	1362	1923	2481	3039	3600	4164
1.5	min	61.7	72.3	81.4	89.5	96.9	103.6	115.9	126.9	150.8	171.3	190.6	216.4	241.4
	max	760	1045	1324	1601	1875	2146	2685	3220	4545	5865	7186	8511	9844
2	min	101.6	119.1	134.2	147.5	159.6	170.8	191	209.2	248.5	282.3	314.1	356.6	397.7
	max	1252	1721	2182	2638	3089	3537	4424	5305	7489	9664	11,839	14,023	16,220
3	min	223.7	262.3	295.4	324.7	351.4	376	420.6	460.5	547.2	621.5	691.5	785.1	875.7
	max	2756	3789	4805	5807	6801	7786	9741	11,680	16,489	21,276	26,067	30,875	35,712
4	min	385.8	452.4	509.4	560	606	648	725.3	794.2	943.6	1072	1193	1354	1510
	max	4753	6535	8286	10,015	11,728	13,428	16,799	20,143	28,436	36,692	44,954	53,246	61,587
6	min	875.4	1026	1156	1271	1375	1471	1646	1802	2141	2432	2706	3072	3427
	max	10,785	14,828	18,802	22,726	26,612	30,470	38,119	45,706	64,524	83,258	102,004	120,820	139,746
Temp <sub>sat</sub>	°F	239	259	274	287	298	307	324	338	366	388	406	422	436
Density <sub>sat</sub>	lb/ft <sup>3</sup>	0.061	0.083	0.106	0.128	0.150	0.171	0.214	0.257	0.363	0.469	0.574	0.679	0.787

Measuring Ranges for Prowirl 72 F Meter Sizes

Dia. (in)		psig 10	20	30	40	50	60	80	100	150	200	250	300	350
0.5	min	7	8	9	10	11	12	13	14	17	19	22	25	27
	max	53	73	93	112	131	150	188	226	319	411	504	597	691
1	min	21	25	28	31	34	36	40	44	53	60	67	76	85
	max	268	368	467	565	661	757	947	1137	1604	2070	2536	3004	3475
1.5	min	62	73	82	90	98	104	117	128	152	173	192	209	226
	max	659	906	1149	1389	1627	1863	2330	2794	3944	5089	6235	7386	8542
2	min	104	122	137	151	163	175	195	214	254	289	320	384	377
	max	1099	1512	1917	2317	2713	3106	3886	4659	6577	8487	10,398	12,316	12,245
3	min	233	273	308	339	366	392	439	480	571	649	718	781	846
	max	2467	3392	4301	5198	6087	6969	8714	10,455	14,759	19,044	23,332	27,636	31,965
4	min	404	474	534	587	635	680	760	833	989	1124	1244	1354	1467
	max	4273	5875	7450	9004	10,544	12,073	15,104	18,110	25,566	32,989	40,416	47,872	55,370
6	min	920	1079	1215	1336	1446	1547	1731	1895	2252	2558	2831	3081	3336
	max	9721	13,365	16,947	20,483	23,986	27,463	34,358	41,196	58,158	75,043	91,940	108,899	125,957
8	min	1766	2073	2334	2566	2775	2971	3321	3637	4322	4909	5435	5914	6405
	max	18,647	25,648	32,545	39,338	46,036	52,736	65,913	79,052	111,627	143,998	176,547	209,055	241,814
10	min	2867	3362	3788	4164	4505	4822	5390	5904	7015	7968	8869	10,067	11,229
	max	30,436	41,862	53,120	64,208	75,140	86,077	107,583	129,028	182,197	235,034	288,161	341,220	391,441
12	min	3947	4629	5215	5733	6202	6638	7421	8128	9659	10,970	12,211	13,862	15,460
	max	41,903	57,635	73,135	88,400	103,450	118,508	148,117	177,643	250,844	323,588	396,732	469,782	538,924
Temp <sub>sat</sub>	°F	239	259	274	287	298	307	324	338	366	388	406	422	436
Density <sub>sat</sub>	lb/ft <sup>3</sup>	0.061	0.083	0.106	0.128	0.150	0.171	0.214	0.257	0.363	0.469	0.574	0.679	0.787

## Mechanical construction

### Design, dimensions

### Transmitter dimensions, remote version

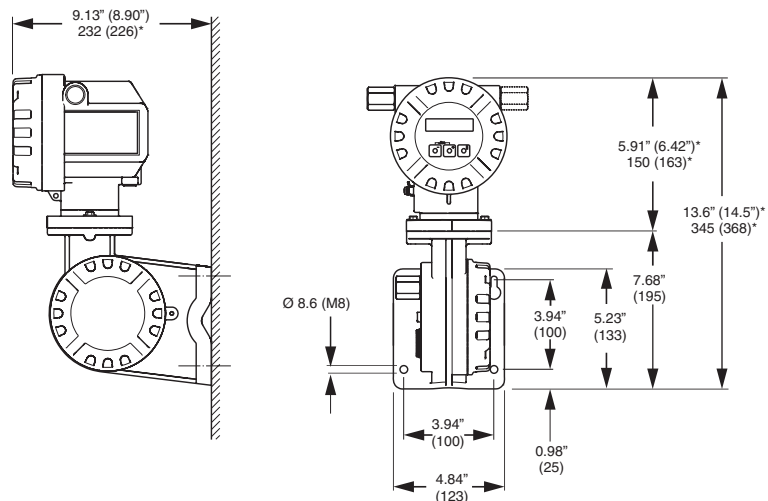

- \* The following dimensions differ depending on the version:
- The dimension 9.13 in (232 mm) changes to 8.90 in (226) mm in the blind version (without local operation).
  - The dimension 5.90 in (150 mm) changes to 6.42 in (163) mm in the Explosion proof version.
  - The dimension 13.6 in (345 mm) changes to 14.5 in (368) mm in the Explosion proof version.

**Prowirl 72 W dimensions**

Wafer version according to:

- ANSI B16.5, Class 150 to 300, Sch40
- DIN and JIS standards available, consult factory

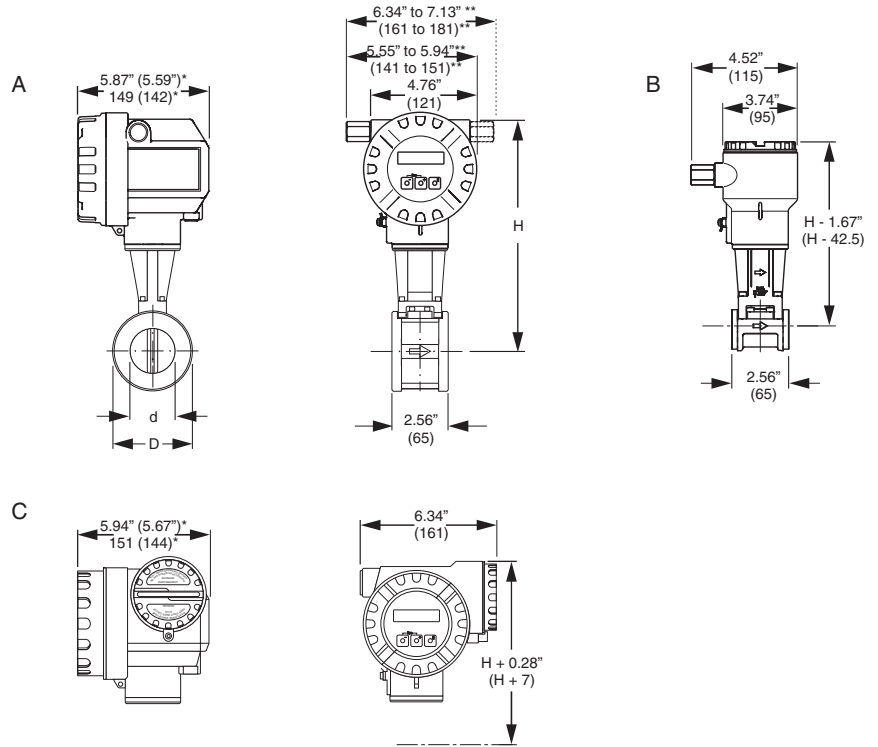

Dimensions:

A = Standard and Intrinsically safe version

B = Remote version

C = Explosion proof version (transmitter)

\* The following dimensions change as follows in the blind version (without local operation):

- Standard and Intrinsically safe version: the dimension 5.87 in (149 mm) changes to 5.59 in (142) mm in the blind version.
- Explosion proof version: the dimension 5.94 in (151 mm) changes to 5.67 in (144) mm in the blind version.

\*\* The dimension depends on the cable gland used.

Note!

- In the following table, dimension H increases by 1.14" (29 mm) in the version with extended temperature range (high temperature version) and in the version with a DSC sensor made of Alloy C-22.
- The weight data refer to the compact version.  
The weight increases by 1 lb (0.5 kg) for the version with extended temperature range.

Nominal Size	d in. (mm)	D in. (mm)	H in. (mm)	Weight lb. (kg)
0.5" 15mm	0.65 (16.5)	1.77 (45.0)	9.7 (247)	6.6 (3.0)
1" 25mm	1.08 (27.6)	2.52 (64.0)	10.1 (257)	7.1 (3.2)
1.5" 40mm	1.65 (42.0)	3.23 (82.0)	10.4 (265)	8.4 (3.8)
2" 50mm	2.10 (53.5)	3.62 (92.0)	10.7 (272)	9.0 (4.1)
3" 80mm	3.15 (80.2)	5.00 (127.0)	11.2 (286)	12.2 (5.5)
4" 100mm	4.12 (104.7)	6.20 (157.2)	11.7 (299)	14.3 (6.5)
6" 150mm	6.17 (156.7)	8.50 (215.9)	12.8 (325)	19.8 (9.0)

**Dimensions of Prowirl 72 F**

Flanged version according to:

- ANSI B16.5, Class 150 to 600,  $R_a = 125$  to  $250 \mu\text{in}$

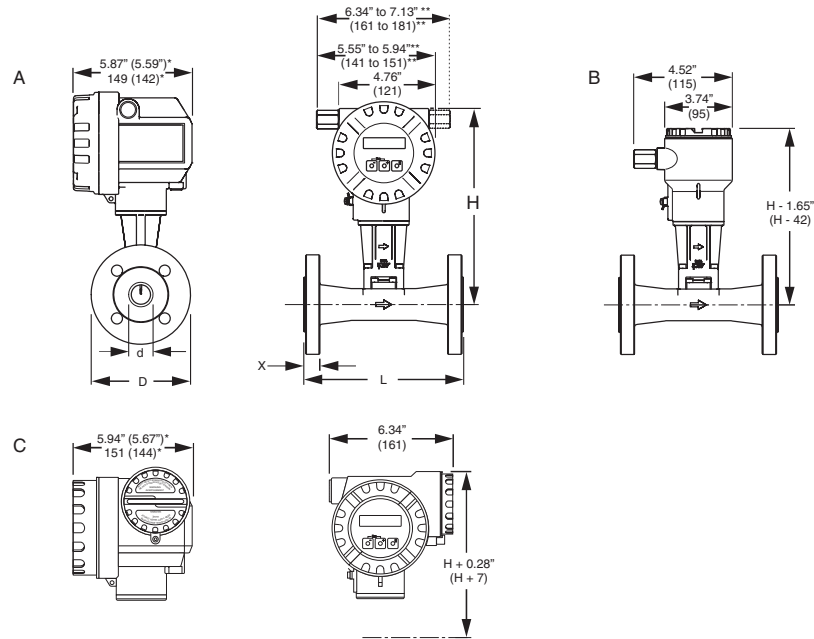

A = Standard and Intrinsically safe version

B = Remote version

C = Explosion proof version (transmitter)

\* The following dimensions change as follows in the blind version (without local operation):

- Standard and Intrinsically safe version: the dimension 5.87 in (149 mm) changes to 5.59 in (142 mm) in the blind version.
- Explosion proof version: the dimension 5.94 in (151 mm) changes to 5.67 in (144 mm) in the blind version.

\*\* The dimension depends on the cable gland used.

**Note!**

- In the following table, dimension H increases by 1.14" (29 mm) in the version with extended temperature range (high temperature version) and in the version with a DSC sensor made of Alloy C-22.
- The weight data refer to the compact version.  
The weight increases by 1 lb (0.5 kg) for the version with extended temperature range.

Nominal Size	Pressure Rating Sch.	ANSI	d	D	H	L	X	Weight					
			in. (mm)	in. (mm)					in. (mm)	in. (mm)	lbs (kg)		
0.5" 15mm	Sch 40	150	0.62 (15.7)	3.50 (88.9)	9.4 (248)	7.8 (200)	0.63 (16)	11 (5)					
		300	0.62 (15.7)	3.74 (95.0)									
	Sch 80	150	0.54 (13.9)	3.50 (88.9)									
		300	0.54 (13.9)	3.74 (95.0)									
	1" 25mm	Sch 40	150	1.05 (26.7)					4.25 (107.9)	11.3 (288)	7.8 (200)	0.91 (23)	13 (6)
			300	1.05 (26.7)					4.87 (123.8)				
Sch 80		150	0.95 (24.3)	4.25 (107.9)									
		300	0.95 (24.3)	4.87 (123.8)									
1.5" 40mm		Sch 40	150	1.05 (26.7)	4.88 (124.0)	11.6 (295)	7.8 (200)	1.06 (27)	20 (9)				
			300	1.05 (26.7)	4.88 (124.0)								
	Sch 80	150	1.61 (40.9)	5.00 (127)									
		300	1.61 (40.9)	6.13 (155.6)									
	2" 50mm	Sch 40	150	1.50 (38.1)	5.00 (127)					11.9 (303)	7.8 (200)	1.22 (31)	28 (13)
			300	1.50 (38.1)	6.12 (155.4)								
Sch 80		150	1.50 (38.1)	6.12 (155.4)									
		300	1.50 (38.1)	6.12 (155.4)									
3" 80mm		Sch 40	150	2.07 (52.6)	6.00 (152.4)	12.2 (310)	7.8 (200)	1.30 (33)	31 (14)				
			300	2.07 (52.6)	6.49 (165)								
	Sch 80	150	1.94 (49.2)	6.00 (152.4)									
		300	1.94 (49.2)	6.49 (165)									
	3" 80mm	Sch 40	150	1.94 (49.2)	6.50 (165.1)					12.7 (323)	7.8 (200)	1.14 (29)	44 (20)
			300	1.94 (49.2)	6.50 (165.1)								
Sch 80		150	3.07 (78)	7.50 (190.5)									
		300	3.07 (78)	8.27 (210)									
3" 80mm		Sch 40	150	2.90 (73.7)	7.50 (190.5)	12.7 (323)	7.8 (200)	1.54 (39)	48 (22)				
			300	2.90 (73.7)	8.27 (210)								
	Sch 80	150	2.90 (73.7)	8.27 (210)									
		300	2.90 (73.7)	8.27 (210)									

Nominal Size	Pressure Rating Sch.	ANSI	d in. (mm)	D in. (mm)	H in. (mm)	L in. (mm)	X in. (mm)	Weight lbs (kg)
4" 100mm	Sch 40	150	4.03 (102.4)	9.00 (228.6)	11.6 (295)	9.8 (250)	1.26 (32)	60 (27)
		300	4.03 (102.4)	10.0 (254)				
	Sch 80	150	3.82 (97)	9.00 (228.6)				
		600	3.82 (97)	10.7 (273.1)				
6" 150mm	Sch 40	150	6.07 (154.2)	11.0 (279.4)	12.5 (319)	11.8 (300)	1.46 (37)	112 (51)
		300	6.07 (154.2)	12.5 (317.5)				
	Sch 80	150	5.76 (146.3)	11.0 (279.4)				
		600	5.76 (146.3)	13.0 (355.6)				
8" 200mm	Sch 40	150	7.98 (202.7)	13.5 (342.9)	13.7 (348)	11.8 (300)	1.65 (42)	141 (64)
		300	7.98 (202.7)	15.0 (381.0)				168 (76)
10" 250mm	Sch 40	150	10.0 (254.5)	16.0 (406.4)	14.7 (375)	14.9 (375)	1.89 (48)	203 (92)
		300	10.0 (254.5)	17.5 (444.5)				240 (109)
12" 300mm	Sch 40	150	12.0 (304.8)	19.0 (482.6)	15.6 (398)	17.7 (450)	2.36 (60)	315 (143)
		300	12.0 (304.8)	20.5 (520.7)				357 (162)

**Dimensions of Prowirl 72 F, Dualsens version**

- ANSI B16.5, Class 150 to 600,  $R_a = 125$  to  $250 \mu\text{m}$

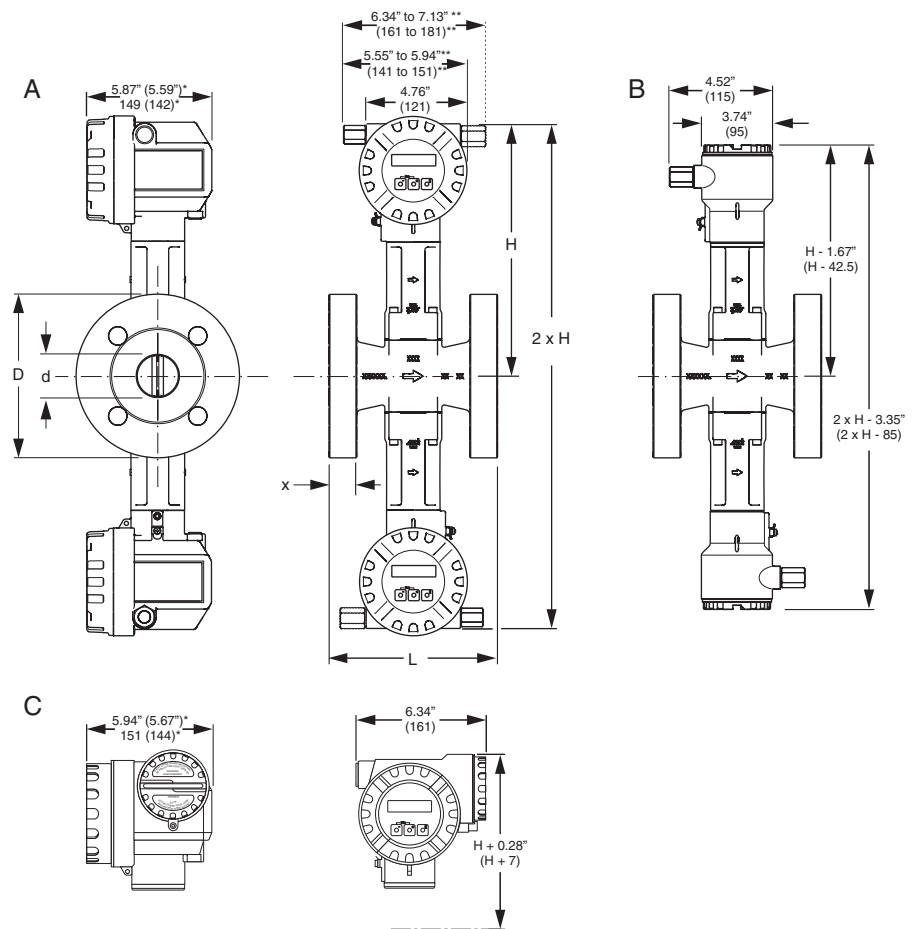

A = Standard and Intrinsically safe version

B = Remote version

C = Explosion proof version (transmitter)

\* The following dimensions change as follows in the blind version (without local operation):

- Standard and Intrinsically safe version: the dimension 5.87 in (149 mm) changes to 5.59 in (142 mm) in the blind version.
- Explosion proof version: the dimension 5.94 in (151 mm) changes to 5.67 in (144 mm) in the blind version.

\*\* The dimension depends on the cable gland used.

Nominal Size	Pressure Rating ANSI	Sch.	d in. (mm)	D in. (mm)	H in. (mm)	L in. (mm)	X in. (mm)	Weight lbs (kg)
1.5" 40mm	150	Sch 40	1.61 (40.9)	5.00 (127.0)	11.9 (303)	7.8 (200)	1.22 (31)	35 (16)
	300		1.61 (40.9)	6.13 (155.6)				
	150	Sch 80	1.50 (38.1)	5.00 (127.0)				
	300		1.50 (38.1)	6.13 (155.6)				
2" 50mm	150	Sch 40	2.07 (56.6)	6.00 (152.4)	12.2 (310)	7.8 (200)	1.30 (33)	40 (18)
	300		2.07 (56.6)	6.50 (165.0)				
	150	Sch 80	1.94 (49.2)	6.00 (152.4)				
	300		1.94 (49.2)	6.50 (165.0)				
3" 80mm	150	Sch 40	3.07 (78.0)	7.50 (190.5)	12.7 (323)	7.8 (200)	1.54 (39)	55 (25)
	300		3.07 (78.0)	8.27 (210.0)				
	150	Sch 80	2.90 (73.7)	7.50 (190.5)				
	300		2.90 (73.7)	8.27 (210.0)				
4" 100mm	150	Sch 40	4.03 (102.4)	9.00 (228.6)	13.2 (335)	9.8 (250)	1.93 (49)	93 (42)
	300		4.03 (102.4)	10.0 (254.0)				
	150	Sch 80	3.82 (97.0)	9.00 (228.6)				
	300		3.82 (97.0)	10.0 (254.0)				
6" 150mm	150	Sch 40	6.07 (154.2)	11.0 (279.4)	14.2 (359)	11.8 (300)	2.52 (64)	176 (80)
	300		6.07 (154.2)	12.5 (317.5)				
	150	Sch 80	5.76 (146.3)	11.0 (279.4)				
	300		5.76 (146.3)	12.5 (317.5)				
600		5.76 (146.3)	14.0 (355.6)					

**Dimensions of flow conditioner, ANSI**

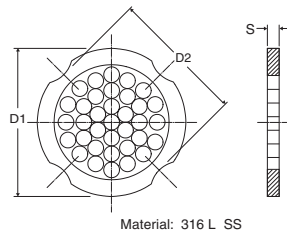

Size	Pressure Rating Class	D1 in. (mm)	D2 in. (mm)	s in. (mm)	Weight lbs (kg)
1/2"	150	2.01 (51.1)	-	0.08 (2.0)	0.07 (0.03)
	300	2.22 (56.5)	-	-	0.09 (0.04)
1"	150	-	2.72 (69.2)	0.14 (3.5)	0.26 (0.12)
	300	2.92 (74.3)	-	-	0.26 (0.12)
1.5"	150	-	3.47 (88.2)	0.21 (5.3)	0.66 (0.3)
	300	-	3.85 (97.7)	-	0.66 (0.3)
2"	150	-	4.20 (106.6)	0.27 (6.8)	1 (0.5)
	300	4.45 (113.0)	-	-	1 (0.5)
3"	150	5.45 (138.4)	-	0.40 (10.1)	3 (1.4)
	300	5.96 (151.3)	-	-	3 (1.4)
4"	150	-	6.95 (176.5)	0.52 (13.3)	6 (2.7)
	300	7.19 (182.6)	-	-	6 (2.7)
6"	150	8.81 (223.9)	-	0.79 (20.0)	14 (6.3)
	300	9.92 (252.0)	-	-	17 (7.8)
8"	150	-	10.8 (274.0)	1.03 (26.3)	27 (12.3)
	300	12.1 (309.0)	-	-	35 (15.8)
10"	150	13.3 (340.0)	-	1.30 (33.0)	57 (25.7)
	300	14.3 (363.0)	-	-	60 (27.5)
12"	150	15.9 (404.0)	-	1.56 (39.6)	80 (36.4)
	300	16.5 (420.0)	-	-	98 (44.6)

Flow conditioner according to ANSI, material 1.4435 (316L)

**Weight**

- Weight of Prowirl 72 W → see dimension table on Page 13.
- Weight of Prowirl 72 F → see dimension tables on Page 14 and 15.
- Weight of Prowirl 72 F, Dualsens version → see dimension table, top of this page.
- Weight of flow conditioner according to ANSI → see dimension table above.

**Material**

- Transmitter housing:
  - Powder-coated die-cast aluminum
- Sensor:
  - Flanged version:
    - 316L Stainless steel, A351-CF3M (1.4404), in conformity with NACE MR 0175;
    - Alloy C-22 version → Alloy C-22 2.4602 (A 494-CX2MW/N 26022), in conformity with NACE MR 0175
  - Wafer version:
    - 316L Stainless steel, A351-CF3M (1.4404), in conformity with NACE MR 0175



- Flanges:
  - EN (DIN) → **316L** Stainless steel, A351-CF3M (1.4404), in conformity with NACE MR 0175 (DN 15 to 150 with pressure rating up to PN 40: as of 2004 changeover from fully cast construction to construction with weld-on flanges in 1.4404)
  - ANSI and JIS → **316L** Stainless steel, A351-CF3M, in conformity with NACE MR 0175 ( ½" to 6" with pressure rating up to CI 300 and DN 15 to 150 with pressure rating up to 20 K: as of 2004 changeover from fully cast construction to construction with weld-on flanges in 316/316L, in conformity with NACE MR 0175)
  - Alloy C-22 version (EN/DIN/ANSI/JIS) → Alloy C-22 2.4602 (A 494-CX2MW/N 26022), in conformity with NACE MR 0175
- DSC sensor (differential switched capacitor; capacitive sensor)
 

Wetted parts (marked as "wet" on the DSC sensor flange):

  - Standard for pressure ratings up to PN 40, CI 300, JIS 40 K (apart from Dualsens version): Stainless steel 1.4435 (317L), in conformity with NACE MR 0175
  - Higher pressure ratings and Dualsens version: Inconel 2.4668/N 07718 (B637) (Inconel 718), in conformity with NACE MR 0175
  - Alloy C-22 sensor: Alloy C-22, 2.4602/N 06022, in conformity with NACE MR 0175
- Non-wetted parts:
  - 304 Stainless steel 1.4301 (CF3)
- Support:
  - 304L Stainless steel, 1.4308 (CF8)
- Seal:
  - Graphite (Grafoil)
  - Viton
  - Kalrez 6375
  - Gylon (PTFE) 3504

## Human interface

<b>Display elements</b>	Liquid crystal display, double-spaced, plain text display, 16 characters per line Display can be configured individually, e.g. for measured variables and status values, totalizers
<b>Operating elements (HART)</b>	Local operation with three keys (◀, ▶, ⏎) Quick Setup for quick commissioning Operating elements accessible also in hazardous areas
<b>Remote operation</b>	Remote operation possible via: <ul style="list-style-type: none"> <li>• HART</li> <li>• PROFIBUS-PA</li> <li>• FOUNDATION Fieldbus</li> <li>• Endress+Hauser Service Protocol</li> </ul>

## Certificates and approvals

<b>CE mark</b>	The device is in conformity with the statutory requirements of the EC Directives. Endress+Hauser confirms successful testing of the device by affixing the CE mark.
<b>Ex-approval</b>	<ul style="list-style-type: none"> <li>• Intrinsically safe:           <ul style="list-style-type: none"> <li>– ATEX/CENELEC               <ul style="list-style-type: none"> <li>II1/2G, EEx ia IIC T1 to T6 (T1 to T4 for PROFIBUS-PA and FOUNDATION Fieldbus)</li> <li>II1/2GD, EEx ia IIC T1 to T6 (T1 to T4 for PROFIBUS-PA and FOUNDATION Fieldbus)</li> <li>II1G, EEx ia IIC T1 to T6 (T1 to T4 for PROFIBUS-PA and FOUNDATION Fieldbus)</li> <li>II2G, EEx ia IIC T1 to T6 (T1 to T4 for PROFIBUS-PA and FOUNDATION Fieldbus)</li> <li>II3G, EEx nA IIC T1 to T6 X (T1 to T4 X for PROFIBUS-PA and FOUNDATION Fieldbus)</li> </ul> </li> </ul> </li> </ul>

- FM IS  
Class I/II/III Div. 1/2, Group A to G
- CSA  
Class I/II/III Div. 1/2, Group A to G  
Class II Div. 1, Group E to G  
Class III
- Explosion proof:
  - ATEX/CENELEC  
II1/2G, EEx d [ia] IIC T1 to T6 (T1 to T4 for PROFIBUS-PA and FOUNDATION Fieldbus)  
II1/2GD, EEx ia IIC T1 to T6 (T1 to T4 for PROFIBUS-PA and FOUNDATION Fieldbus)  
II2G, EEx d [ia] IIC T1 to T6 (T1 to T4 for PROFIBUS-PA and FOUNDATION Fieldbus)
  - FM  
Class I/II/III Div. 1, Groups A to G
  - CSA  
Class I/II/III Div. 1,2 Groups A to G  
Class II Div. 1, Groups E to G  
Class III

More information on the Ex-approvals can be found in the separate Ex-documentation.

---

**Pressure measuring device approval**

Devices with a nominal diameter smaller than or equal to 1" (DN 25) correspond to Article 3 (3) of the EC Directive 97/23/EC (Pressure Equipment Directive). For larger nominal diameters, certified flowmeters to Category III are optionally also available if necessary (depends on fluid and operating pressure). All devices are applicable for all fluids and instable gases on principle and have been designed and manufactured in accordance to sound engineering practice.

---

**Certification FOUNDATION Fieldbus**

The flowmeter has successfully passed all test procedures and is certified and registered by the Fieldbus FOUNDATION. The device thus meets all the requirements of the specifications following:

- Certified according to FOUNDATION Fieldbus Specification
- The device meets all the specifications of the FOUNDATION Fieldbus-H1
- Interoperability Test Kit (ITK), revision status 4.5 (device certification no. available on request):  
The device can also be operated with certified devices of other manufacturers
- Physical Layer Conformance Test of the Fieldbus FOUNDATION

---

**Certification PROFIBUS-PA**

The flowmeter has successfully passed all test procedures and is certified and registered by the PNO (PROFIBUS User Organization). The device thus meets all the requirements of the specifications following:

- Certified according to PROFIBUS-PA profile version 3.0 (device certification number available on request)
- The device can also be operated with certified devices of other manufacturers (interoperability)

---

**Other standards and guidelines**

- EN 60529: Degrees of protection by housing (IP code).
- EN 61010: Protection measures for electrical equipment for measurement, control, regulation and laboratory procedures.
- EN 61326/A1: Electromagnetic compatibility (EMC requirements).
- NAMUR NE 21: Electromagnetic compatibility (EMC) of industrial process and laboratory control equipment.
- NAMUR NE 43: Standardization of the signal level for the breakdown information of digital transmitters with analog output signal.
- NACE Standard MR0175: Standard Material Requirements - Sulfide Stress Cracking Resistant Metallic Materials for Oilfield Equipment.
- VDI 2643: Measurement of fluid flow by means of vortex flowmeters.
- ANSI/ISA-S82.01: Safety Standard for Electrical and Electronic Test, Measuring, Controlling and related Equipment - General Requirements. Pollution degree 2, Installation Category II
- CAN/CSA-C22.2 No. 1010.1-92: Safety Standard for Electrical Equipment for Measurement and Control and Labatory Use. Pollution degree 2, Installation Category II

## Accessories

- Wafer version mounting set
- Spare parts as per separate price list
- Replacement transmitter Prowirl 72
- Universal flow and energy computer RMC 621
- Steam computer RMS-621
- Compact DXF 351 flow computer
- Flow conditioner
- HART Communicator DXR 275 handheld terminal
- HART Communicator DXR 375 handheld terminal
- Active barrier preline RN 221 N
- Pressure transducer Cerabar T resp. Cerabar S (PROFIBUS-PA, FOUNDATION Fieldbus)
- Thermoresistance Omnigrad TR 10
- Process display RIA 250, RIA 251
- Field display RIA 261 resp. RID 261 (PROFIBUS-PA)
- Applicator
- ToF Tool - FieldTool Package
- Fieldgate FXA 520

## Documentation

- Operating Instructions PROline Prowirl 72
- Operating Instructions PROline Prowirl 72 PROFIBUS-PA
- Operating Instructions PROline Prowirl 72 FOUNDATION Fieldbus
- Related Ex-documentation
- System Information PROline Prowirl 72
- System Information PROline Prowirl 72/73
- Related documentation for Pressure Equipment Directive

## Additional ordering information for Prowirl 72

You can order Prowirl 72 with pre-programming of the most important parameters. For this purpose the following information is required when ordering the device:

- 20 mA value = measured value (e.g. 1000 kg/h) that shall result in a current of 20 mA
- Pulse value (if the device is ordered with a pulse output)

If you want to display the flow in mass units, please indicate in addition:

- the mean operation density of your media including units

If you want to display the flow in corrected volume flow units, please indicate in addition:

- the operation and the reference density of your media including units

You can reset the device to this ordered state later on.

**Ordering information**

PROline Prowirl 72 F (Flanged version)

72F -  1  2  3  4  5  6  7  8 (order codes 9 - 13, refer to page 21)

- 1 Nominal diameters / measuring range
  - 15 1/2" / Gas: 1.77 to 14.1 ft<sup>3</sup>/min, Liquid: 0.7 to 2.2 gpm
  - 25 1" / Gas: 5.3 to 73.6 ft<sup>3</sup>/min, Liquid: 1.41 to 66 gpm
  - 40 1-1/2" / Gas: 14.7 to 182 ft<sup>3</sup>/min, Liquid: 3.96 to 163 gpm
  - 50 2" / Gas: 24.7 to 300 ft<sup>3</sup>/min, Liquid: 6.6 to 273 gpm
  - 80 3" / Gas: 55.9 to 677 ft<sup>3</sup>/min, Liquid: 15 to 616 gpm
  - 1H 4" / Gas: 97.1 to 1177 ft<sup>3</sup>/min, Liquid: 26.4 to 1056 gpm
  - 1F 6" / Gas: 220 to 2672 ft<sup>3</sup>/min, Liquid: 57 to 2422 gpm
  - 2H 8" / Gas: 420 to 5126 ft<sup>3</sup>/min, Liquid: 114 to 4623 gpm
  - 2F 10" / Gas: 663 to 8087 ft<sup>3</sup>/min, Liquid: 181 to 6265 gpm
  - 3H 12" / Gas: 952 to 11,595 ft<sup>3</sup>/min, Liquid: 255 to 10,391 gpm
  
- 2 Sensor material
  - S 316L SS, -330° to +750°F
  - C Alloy C-22, -40° to +500°F
  
- 3 Process connections
  - K Class 150, Schedule 40, ANSI B16.5, RF
  - L Class 150, Schedule 80, ANSI B16.5, RF
  - M Class 300, Schedule 40, ANSI B16.5, RF
  - N Class 300, Schedule 80, ANSI B16.5, RF
  - P Class 600, Schedule 80, ANSI B16.5, RF (not for Alloy c-22, sensor material C. only for DSC sensor 2, Inconel, -330° to +750°F)

NOTE: DIN and JIS flanges available, contact factory
  
- 4 DSC sensor
  - 0 316L SS standard sensor, -40° to +500°F (not for process connection P, Class 600 ANSI)
  - 1 316L SS, high/low temperature, -330° to +750°F (not for process connection P, Class 600 ANSI)
  - 2 Inconel sensor, -330° to +750°F
  - 3 Alloy C-22 sensor, -330° to +750°F (not for process connection P, Class 600 ANSI)
  
- 5 DSC sensor seal
  - A Grafoil (graphite), -330° to +750°F
  - B Viton, +5° to +345°F
  - C Kalrez, -5° to +527°F
  - D Oil/fat/water-free, Grafoil (graphite), -330° to +750°F
  - E Oil/fat/water-free, Viton, +5° to +345°F
  - F Gylon (PTFE), -330° to +500°F
  - G Oil/fat/water-free, Gylon (PTFE), -330° to +500°F (not for 8" to 12" sensors)
  
- 6 Calibration
  - A 3-point calibration, standard
  - C 5-point calibration, standard
  - D SCS/A2LA 3-point calibration (ISO/IEC 17025), with certificate traceable to ISO 9000
  
- 7 Certificates
  - 1 Standard version without certificate
  - 3 2.3 pressure test certificate (1.5 x PN, 3 minutes)
  - 4 3.1B material and 2.3 pressure test certificate
  - 5 CRN approval (for ANSI flanges only)
  - 8 CRN approval, 3.1B and 2.3 pressure test (for ANSI flanges only)
  - P Approval according to PED Cat. III (not for 1/2", 1")
  - R Approval according to PED Cat. III, 3.1B material certificate included (not for 1/2", 1")
  
- 8 Approvals
  - A Standard, nonhazardous areas
  - N FM intrinsically safe, CL I, II, III; Div. 1,2; Grps. A-G  
CSA Class I, II, III; Div. 1, 2; Grps. A-G; Class II, Div. 1, Grps. E-G; Class III
  - P FM Explosion proof, Class I, II, III; Div. 1, Grps. A-G  
CSA Class I, II, III; Div. 1, 2; Grps. A-G; Class II, Div. 1, Grps. E-G; Class III

NOTE: ATEX approvals available, consult factory

## PROline Prowirl 72 F (con't)

9 10 11 12 13

- 9 Protection type / version
- A NEMA 4X (IP 67) / compact, aluminum field housing
  - E NEMA 4X (IP 67) / remote, aluminum field housing, 30 ft cable
  - F NEMA 4X (IP 67) / remote, aluminum field housing, 90 ft cable
  - J NEMA 4X (IP 67) / compact, dualsens aluminum field housing  
(not for sensor material C, Alloy C-22; only for DSC sensor 2, Inconel)
  - K NEMA 4X (IP 67) / dualsens remote, aluminum field housing, 30 ft cable  
(not for sensor material C, Alloy C-22 only for DSC sensor 2, Inconel)
  - L NEMA 4X (IP 67) / dualsens remote, aluminum field housing, 90 ft of cable  
(not for sensor material C, Alloy C-22 only for DSC sensor 2, Inconel)
- 10 Cable entries
- B 1/2" NPT
  - L Fieldbus connector and 1/2" NPT thread (not for protection type A, J; not for approvals N or P)
- 11 Display / operation
- 0 Without display, remote configuration only
  - 4 With display, push-button operation (not for output/input H, K)
  - 6 With display, remote configuration only (not for output/input W, A)
  - K Without display, remote configuration, enhanced climate resistance  
(not for output/input H, K)
- 12 Software
- A Standard software
- 13 Outputs / Inputs
- W 4 to 20 mA HART
  - A 4 to 20 mA HART, can be configured as PFM output
  - H PROFIBUS-PA
  - K FOUNDATION Fieldbus

**Ordering information**

PROline Prowirl 72 W (Wafer version)

72W -               (order codes 10-13, refer to page 23)

- 1 Nominal diameters / measuring range
  - 15 1/2" / Gas: 2.35 to 20.6 ft<sup>3</sup>/min, Liquid: 0.84 to 30.8 gpm
  - 25 1" / Gas: 6.47 to 94.2 ft<sup>3</sup>/min, Liquid: 1.76 to 83.7 gpm
  - 40 1-1/2" / Gas: 18.2 to 221 ft<sup>3</sup>/min, Liquid: 4.8 to 198 gpm
  - 50 2" / Gas: 29.4 to 359 ft<sup>3</sup>/min, Liquid: 7.93 to 321 gpm
  - 80 3" / Gas: 65.9 to 806 ft<sup>3</sup>/min, Liquid: 17.6 to 722 gpm
  - 1H 4" / Gas: 112 to 1371 ft<sup>3</sup>/min, Liquid: 30.4 to 1228 gpm
  - 1F 6" / Gas: 252 to 3066 ft<sup>3</sup>/min, Liquid: 67.8 to 2752 gpm
  
- 2 Sensor material
  - S 316L SS
  
- 3 Process connections
  - K Class 150, Schedule 40, ANSI B16.5, RF
  - M Class 300, Schedule 40, ANSI B16.5, RF
  - NOTE: DIN and JIS flanges available, contact factory
  
- 4 DSC sensor
  - 0 316L SS standard version, -40° to +500°F
  - 1 316L SS high/low temperature, -330° to +750°F
  - 3 Alloy C-22, -330° to +750°F
  - 4 316L with thermometer, -330° to +750°F
  
- 5 DSC sensor seal
  - A Grafoil (graphite), -330° to +750°F
  - B Viton, +5° to +345°F
  - C Kalrez, -5° to +527°F
  - D Oil/fat/water-free, Grafoil (graphite), -330° to +750°F
  - E Oil/fat/water-free, Viton, +5° to +345°F
  - F Gylon (PTFE), -330° to +500°F
  - G Oil/fat/water-free, Gylon (PTFE), -330° to +500°F (not for 8" to 12" sensors)
  
- 6 Calibration
  - A 3-point calibration, standard
  - C 5-point calibration, standard
  - D SCS/A2LA 3-point calibration (ISO/IEC 17025), with certificate traceable to ISO 9000
  
- 7 Certificates
  - 1 Standard version without certificate
  - 3 2.3 pressure test certificate (1.5 x PN, 3 minutes)
  - 4 3.1B material and 2.3 pressure test certificate
  - 5 CRN approval (for ANSI flanges only)
  - 8 CRN approval, 3.1B and 2.3 pressure test (for ANSI flanges only)
  - P Approval according to PED Cat. III (not for 1/2", 1")
  - R Approval according to PED Cat. III, 3.1B material certificate included (not for 1/2", 1")
  
- 8 Approvals
  - A Standard, nonhazardous areas
  - N FM intrinsically safe, CL I, II, III; Div. 1,2; Grps. A-G  
CSA Class I, II, III; Div. 1, 2; Grps. A-G; Class II, Div. 1, Grps. E-G; Class III
  - P FM Explosion proof, Class I, II, III; Div. 1, Grps. A-G  
CSA Class I, II, III; Div. 1, 2; Grps. A-G; Class II, Div. 1, Grps. E-G; Class III
  - NOTE: ATEX approvals available, consult factory
  
- 9 Protection type / version
  - A NEMA 4X (IP 67) / compact, aluminum field housing
  - E NEMA 4X (IP 67) / remote, aluminum field housing, 30 ft cable
  - F NEMA 4X (IP 67) / remote, aluminum field housing, 90 ft cable

## PROline Prowirl 72 W(con't)

10 11 12 13

- 10 Cable entries  
 B 1/2" NPT  
 L Fieldbus connector and 1/2" NPT thread (not for protection type A, J; not for approvals N or P)
- 11 Display / operation  
 0 Without display, remote configuration only  
 4 With display, push-button operation (not for output/input H, K)  
 6 With display, remote configuration only (not for output/input W, A)  
 K Without display, remote configuration, enhanced climate resistance (not for output/input H, K)
- 12 Software  
 A Standard software, steam, water and compressed air data
- 13 Outputs / Inputs  
 W 4 to 20 mA HART  
 A 4 to 20 mA HART, pulse, can be configured as PFM output  
 H PROFIBUS-PA  
 K FOUNDATION Fieldbus

DKW Mounting set for Prowirl 72/73 Wafer version.  
 Kit includes mounting hardware - centering rings, threaded bolts, nuts, washers and a pair of flange gaskets.

DKW -

- 1 Nominal diameters  
 15 1/2"  
 25 1"  
 40 1-1/2"  
 50 2"  
 80 3"  
 1H 4"  
 1F 6"
- 2 Process connections  
 K Class 150, ANSI B16.5  
 M Class 300, ANSI B16.5  
 NOTE: DIN and JIS flanges available, contact factory
- 3 Mounting hardware material  
 0 Galvanized steel, T > -60°F  
 1 A2-70 bolts and nuts  
 2 A2-70 bolts and nuts, 3.1B (not for ANSI or JIS)
- 4 Seal material  
 0 Graphite, -330° to +750°F  
 1 Fat-free graphite, -330° to +750°F  
 2 Viton gaskets, fat-free, +5° to +345°F  
 3 Viton gaskets, +5° to +345°F

For application and selection assistance,  
in the U.S. call 888-ENDRESS

For total support of your installed base, 24 hours  
a day, in the U.S. call 800-642-8737

Visit us on our web site, [www.us.endress.com](http://www.us.endress.com)

---

**United States**

Endress+Hauser, Inc.  
2350 Endress Place  
Greenwood, IN 46143  
Phone: (317) 535-7138  
888-ENDRESS  
FAX: (317) 535-8498

**Canada**

Endress+Hauser  
Canada Ltd.  
1440 Graham's Lane  
Unit 1, Burlington  
ON, L7S 1W3  
Phone: (905) 681-9292  
800-668-3199  
FAX: (905) 681-9444

**Mexico**

Endress+Hauser  
Paseo del Pedregal No. 610  
Col. Jardines del Pedregal  
01900, Mexico D.F.  
Mexico  
Phone: (525) 568-2405  
FAX: (525) 568-7459

---

**Endress+Hauser**  
The Power of Know How

