

# Model 266DRH Differential Model 266PRH and 266HRH Gauge Model 266VRH and 266NRH Absolute

## 2600T Series Pressure Transmitters Engineered solutions for all applications



### Base accuracy

- from 0.06 % of calibrated span

### Reliable sensing system coupled with very latest digital technologies

- provides large turn down ratio up to 60:1

### Comprehensive sensor choice

- optimize in-use total performance and stability

### Flexible configuration facilities

- provided locally via local LCD keypad

### New TTG (Through-The-Glass) keypad technology

- allows quick and easy local configuration without opening the cover, even in explosion proof environments

### IEC 61508 certification

- for SIL2 (1oo1) and SIL3 (1oo2) applications

### PED compliance to sound engineering practice (SEP)

# Model 266DRH Differential Model 266PRH and 266HRH Gauge Model 266VRH and 266NRH Absolute

## General description

Models detailed in this data sheet apply for those transmitters which include one or two remote seal(s) connected via a capillary to the transmitter sensor. Depending on the selected ordering code the following models are available:

- a) model 266DRH which allows a differential measurement using either two remote seals of same type and size or one remote seal (on positive or negative side) and a standard threaded connection direct 1/4 – 18 NPT on flange or 1/2 – 14 NPT through adapter, for the wet or dry leg on the side opposite to seal.
- b) models 266PRH or 266VRH allowing gauge or absolute measurement respectively with the reference side at atmosphere or at vacuum. The other side which can be the positive or negative (high or low pressure side) features the required remote seal. Model 266HRH or 266NRH have the remote seal on the positive side and the user can select the suitable code for having the reference at atmospheric or vacuum pressure respectively for gauge or absolute measure. The following table list the types of standard seal which can be combined with 266xR transmitters. Refer to seal data sheet for all data and details relevant to seal element. All following data apply for identical characteristics of the two sides when the transmitter is differential with two seals.

Seal model	Seal type	Seal diaphragm size (thickness)	Mnemonic
S26WA S26WE	Wafer (ASME and EN standards)	1.5 in. /DN 40	P1.5
		2 in. / DN 50	P2
		3 in. / DN 80	P3
		1.5 in. /DN 40 (low)	F1.5
		2 in. / DN 50 (low)	F2
		3 in. / DN 80 (low)	F3
S26FA S26FE S26RA S26RE	Flanged flush diaphragm (ASME and EN standards; fixed and rotating flange)	2 in. / DN 50	P2
		3 in. / DN 80	P3
		4 in. / DN 100	P3
		2 in. / DN 50 (low)	F2
	Flanged extended diaphragm (ASME and EN standards; only rotating flange S26RA and S26RE)	3 in. / DN 80 (low)	F3
		4 in. / DN 100 (low)	F3
S26RJ	Flanged flush diaphragm (JIS standards; only rotating flange)	A 50	P2
		A 80	P3
		A 100	P3
S26RR	Flanged flush diaphragm (Ring Joint ASME standards; rotating flange)	1.5 in.	P1.5
		2 in.	P2
		3 in.	P3
S26CN	Flanged Chemical Tee	3 in.	P3
S26TT	Threaded off-line flanged	2 1/2 in.	T 2.5
S26MA, S26ME	Off-line flanged (ASME and EN standards)	2 1/2 in.	T 2.5
S26SS	Union nut, Triclamp Cherry Burrel Sanitary, Aseptic	2 in. / F50	S2
		3 in. / F80	S3
		4 in.	S3
S26VN	Saddle and Socket	2 1/2 in.	P1.5
S26UN	Union connection type	1 1/2 in.	Z 1.5
S26BN	Button type	1 in.	B1
S26PN	Urea service flanged	1 1/2 in.	U1.5
		2 1/2 in.	U 2.5

## Functional Specifications

### Range and span limits

Sensor Code	Upper Range Limit (URL)	Lower Range Limit (LRL)				266NRH absolute	Minimum span
		266DRH differential	266PRH gauge	266VRH absolute	266HRH gauge		
B	4 kPa 40 mbar 16 inH2O	-4 kPa -40 mbar -16 inH2O					0.2 kPa 2 mbar 0.8 inH2O
E	16 kPa 160 mbar 64 inH2O	-16 kPa -160 mbar -64 inH2O	-16 kPa -160 mbar -64 inH2O	0.07 kPa abs (\$) 0.7 mbar abs (\$) 0.5 mmHg (\$)			0.8 kPa 8 mbar 3.2 inH2O
F	40 kPa 400 mbar 160 inH2O	-40 kPa -400 mbar -160 inH2O	-40 kPa -400 mbar -160 inH2O	0.07 kPa abs (\$) 0.7 mbar abs (\$) 0.5 mmHg (\$)			0.67 kPa 6.7 mbar 2.67 inH2O
G	65 kPa 650 mbar 260 inH2O	-65 kPa -650 mbar -260 inH2O	-65 kPa -650 mbar -260 inH2O	0.07 kPa abs (\$) 0.7 mbar abs (\$) 0.5 mmHg (\$)	-65 kPa -650 mbar -260 inH2O	0.07 kPa abs (\$) 0.7 mbar abs (\$) 0.5 mmHg (\$)	1.1kPa 11 mbar 4.35 inH2O
H	160 kPa 1600 mbar 642 inH2O	-160 kPa -1600 mbar -642 inH2O	0.07 kPa abs (\$) 0.7 mbar abs (\$) 0.5 mmHg (\$)	0.07 kPa abs (\$) 0.7 mbar abs (\$) 0.5 mmHg (\$)	0.07 kPa abs (\$) 0.7 mbar abs (\$) 0.5 mmHg (\$)	0.07 kPa abs (\$) 0.7 mbar abs (\$) 0.5 mmHg (\$)	2.67 kPa 26.7 mbar 10.7 inH2O
M	600 kPa 6 bar 87 psi	-600 kPa -6 bar -87 psi	0.07 kPa abs (\$) 0.7 mbar abs (\$) 0.5 mmHg (\$)	0.07 kPa abs (\$) 0.7 mbar abs (\$) 0.5 mmHg (\$)	0.07 kPa abs (\$) 0.7 mbar abs (\$) 0.5 mmHg (\$)	0.07 kPa abs (\$) 0.7 mbar abs (\$) 0.5 mmHg (\$)	10kPa 0.1 bar 1.45 psi
P	2400 kPa 24 bar 348 psi	-2400 kPa -24 bar -348 psi	0.07 kPa abs (\$) 0.7 mbar abs (\$) 0.5 mmHg (\$)	0.07 kPa abs (\$) 0.7 mbar abs (\$) 0.5 mmHg (\$)	0.07 kPa abs (\$) 0.7 mbar abs (\$) 0.5 mmHg (\$)	0.07 kPa abs (\$) 0.7 mbar abs (\$) 0.5 mmHg (\$)	40 kPa 0.4 bar 5.8 psi
Q	8000 kPa 80 bar 1160 psi	-8000 kPa -80 bar -1160 psi	0.07 kPa abs (\$) 0.7 mbar abs (\$) 0.5 mmHg (\$)	0.07 kPa abs (\$) 0.7 mbar abs (\$) 0.5 mmHg (\$)	0.07 kPa abs (\$) 0.7 mbar abs (\$) 0.5 mmHg (\$)	0.07 kPa abs (\$) 0.7 mbar abs (\$) 0.5 mmHg (\$)	134 kPa 1.34 bar 19.4 psi
S	16000 kPa 160 bar 2320 psi	-16000 kPa -160 bar -2320 psi	0.07 kPa abs (\$) 0.7 mbar abs (\$) 0.5 mmHg (\$)	0.07 kPa abs (\$) 0.7 mbar abs (\$) 0.5 mmHg (\$)	0.07 kPa abs (\$) 0.7 mbar abs (\$) 0.5 mmHg (\$)	0.07 kPa abs (\$) 0.7 mbar abs (\$) 0.5 mmHg (\$)	267 kPa 2.67 bar 38.7 psi
V	60000 kPa 600 bar 8700 psi				0.07 kPa abs (\$) 0.7 mbar abs (\$) 0.5 mmHg (\$)		1000 kPa 10 bar 145 psi

(§) Lower Range Limit is 0.135 kPa abs, 1.35 mbar abs, 1 mmHg for inert Galden or 0.4 kPa abs, 4 mbar abs, 3 mmHg for inert Halocarbon.

### Span limits

Maximum span = URL (can be further adjusted up to  $\pm$  URL (TD = 0.5) for differential models, within the range limits)  
IT IS RECOMMENDED TO SELECT THE TRANSMITTER SENSOR CODE PROVIDING THE TURNDOWN VALUE AS LOWEST AS POSSIBLE TO OPTIMIZE PERFORMANCE CHARACTERISTICS.

### Zero suppression and elevation

Zero and span can be adjusted to any value within the range limits detailed in the table as long as:  
– calibrated span  $\geq$  minimum span

### Damping

Selectable time constant : between 0 and 60 s  
This is in addition to sensor response time.

### Turn on time

Operation within specification in less than 10 s with minimum damping.

### Insulation resistance

> 100 M $\Omega$  at 500 V DC (terminals to earth)

# Model 266DRH Differential Model 266PRH and 266HRH Gauge Model 266VRH and 266NRH Absolute

## Operative limits

REFER ALSO TO S26X DATA SHEET FOR POSSIBLE FURTHER LIMITATION DUE TO SEAL VARIANTS

### Pressure limits:

#### Overpressure limits

Without damage to the transmitter

Models 266DRH, 266PRH, 266VRH	Fill fluid	Overpressure limits
Sensor F to S	Silicone oil	0.07 kPa abs, 0.7 mbar abs, 0.5 mmHg and 21 MPa, 210 bar, 3045 psi <sup>(1)</sup>
Sensor E	Silicone oil	0.07 kPa abs, 0.7 mbar abs, 0.5 mmHg and 16 MPa, 160 bar, 2320 psi
Sensor B	Silicone oil	0.07 kPa abs, 0.7 mbar abs, 0.5 mmHg and 7 MPa, 70 bar, 1015 psi
Sensor F to S	Inert (Galden)	0.135 kPa abs, 1.35 mbar abs, 1 mmHg and 21 MPa, 210 bar, 3045 psi <sup>(1)</sup>
Sensor E	Inert (Galden)	0.135 kPa abs, 1.35 mbar abs, 1 mmHg and 16 MPa, 160 bar, 2320 psi
Sensor F to S	Inert (Halocarbon)	0.4 kPa abs, 4 mbar abs, 3 mmHg and 21 MPa, 210 bar, 3045 psi <sup>(1)</sup>
Sensor E	Inert (Halocarbon)	0.4 kPa abs, 4 mbar abs, 3 mmHg and 16 MPa, 160 bar, 2320 psi

(1) 16 MPa, 160 bar, 2320 psi for AISI 316 ss NACE bolting

Models 266HRH and 266NRH	Fill fluid	Overpressure limits
Sensor P, Q, S	Silicone oil	0.07 kPa abs, 0.7 mbar abs, 0.5 mmHg and 21 MPa, 210 bar, 3045 psi
Sensor G, H, M	Silicone oil	0.07 kPa abs, 0.7 mbar abs, 0.5 mmHg and 14 MPa, 140 bar, 2030 psi
Sensor P, Q, S	Inert (Galden)	0.135 kPa abs, 1.35 mbar abs, 1 mmHg and 21 MPa, 210 bar, 3045 psi
Sensor G, H, M	Inert (Galden)	0.135 kPa abs, 1.35 mbar abs, 1 mmHg and 14 MPa, 140 bar, 2030 psi
Sensor P, Q, S	Inert (Halocarbon)	0.4 kPa abs, 4 mbar abs, 3 mmHg and 21 MPa, 210 bar, 3045 psi
Sensor G, H, M	Inert (Halocarbon)	0.4 kPa abs, 4 mbar abs, 3 mmHg and 14 MPa, 140 bar, 2030 psi
Sensor V	Silicone oil	0.07 kPa abs, 0.7 mbar abs, 0.5 mmHg and 90 MPa, 900 bar, 13050 psi

## Static pressure limits

Transmitters for differential pressure model 266DRH operates within specifications between the following limits:

Sensors	Static pressure limits
Sensor F to S with 2 seals	0.07 kPa abs, 0.7 mbar abs, 0.5 mmHg and 21 MPa, 210 bar, 3045 psi <sup>(1)</sup>
Sensor F to S with 1 seal	1.3 kPa abs, 13 mbar abs, 0.2 psia and 21 MPa, 210 bar, 3045 psi <sup>(1)</sup>
Sensor E with 2 seals	0.07 kPa abs, 0.7 mbar abs, 0.5 mmHg and 16 MPa, 160 bar, 2320 psi
Sensor E with 1 seal	1.3 kPa abs, 13 mbar abs, 0.2 psia and 16 MPa, 160 bar, 2320 psi
Sensor B with 2 seals	0.07 kPa abs, 0.7 mbar abs, 0.5 mmHg and 7 MPa, 70 bar, 1015 psi
Sensor B with 1 seal	1.3 kPa abs, 13 mbar abs, 0.2 psia and 7 MPa, 70 bar, 1015 psi

(1) 16 MPa, 160 bar, 2320 psi for AISI 316 ss NACE bolting

Overpressure and static upper limit can be derated by the flange rating of seal; refer to relevant S26 data sheet

## Proof pressure

The transmitter can be exposed without leaking to line pressure of up to

Model	Sensor	Proof pressure
266DRH	Sensor F to S	40.25 MPa, 402.5 bar, 5836 psi
	Sensor E	31.5 MPa, 315 bar, 4567 psi
	Sensor B	14 MPa, 140 bar, 2030 psi
266PRH	Sensor F to S	40.25 MPa, 402.5 bar, 5836 psi
266VRH	Sensor E	31.5 MPa, 315 bar, 4567 psi
266HRH	Sensor G, H, M	28 MPa, 280 bar, 4060 psi
266NRH	Sensor P, Q, S	40.25 MPa, 402.5 bar, 5836 psi
266HRH	Sensor V	90 MPa, 900 bar, 13050 psi

or two times the flange rating of seal, whichever is less. Meet ANSI/ISA-S 82.03 hydrostatic test requirements.

## Temperature limits °C ( °F) :

### Ambient

is the operating temperature

Models 266DRH, 266PRH, 266VRH	Ambient temperature limits
Silicone oil for sensor F to S	-40 and 85 °C (-40 and 185 °F)
Silicone oil for sensor B and E	-25 and 85 °C (-13 and 185 °F)
Inert (Galden) for sensor F to S	-20 and 85 °C (-4 and 185 °F)
Inert (Galden) for sensor E	-10 and 85 °C (14 and 185 °F)
Inert (Halocarbon) for sensor F to S	-20 and 85 °C (-4 and 185 °F)
Inert (Halocarbon) for sensor E	-10 and 85 °C (14 and 185 °F)

Model 266HRH - 266NRH	Ambient temperature limits
Silicone oil for sensor G to V	-40 and 85 °C (-40 and 185 °F)
Inert (Galden) for sensor G to S	-20 and 85 °C (-4 and 185 °F)
Inert (Halocarbon) for sensor G to S	-20 and 85 °C (-4 and 185 °F)

Models 266XRH	Ambient temperature limits
LCD integral display	-40 and 85 °C (-40 and 185 °F)

LCD display may not be clearly readable below -20 °C (-4 °F) or above +70 °C (+158 °F)

### IMPORTANT

For Hazardous Atmosphere applications see the temperature range specified on the certificate/approval relevant to the aimed type of protection

### Process

Model 266DRH (side without seal)	Process temperature limits
Silicone oil for sensor F to S	-40 and 121 °C (-40 and 250 °F) <sup>(1)</sup>
Silicone oil for sensor B and E	-25 and 121 °C (-13 and 250 °F) <sup>(1)</sup>
Inert (Galden) for sensor F to S	-20 and 100 °C (-4 and 212 °F) <sup>(2)</sup>
Inert (Galden) for sensor E	-10 and 100 °C (14 and 212 °F) <sup>(2)</sup>
Inert (Halocarbon) for sensor F to S	-20 and 100 °C (-4 and 212 °F) <sup>(2)</sup>
Inert (Halocarbon) for sensor E	-10 and 100 °C (14 and 212 °F) <sup>(2)</sup>
Viton gasket	-20 and 121 °C (-4 and 250 °F)

(1) 100 °C (212 °F) for application below atmospheric pressure

(2) 65 °C (150 °F) for application below atmospheric pressure

The following table show characteristics of fill fluids when used in transmitters with remote seal(s).

Fill fluid (application)	Process temperature and pressure limits			
	Tmax @ Pabs > of	Pmin mbar abs (mmHg)	Tmax @ Pmin	Tmin
Silicone oil DC 200 10 cSt	250 (480) @ 385 mbar	0.7 (0.5)	130 (266)	-40 (-40)
Silicone oil Baysilone PD5 5 cSt	250 (480) @ 900 mbar	0.7 (0.5)	45 (123)	-85 (-121)
Inert oil Galden G5 (oxygen service)	160 (320) @ 1 bar	2.1 (1.52)	60 (140)	-20 (-4)
Inert oil Halocarbon 4.2 (oxygen service)	180 (356) @ 425 mbar	4 (3)	70 (158)	-20 (-4)
Silicone polymer Syltherm XLT (cryogenic service)	100 (212) @ 118 mbar	2.1 (1.52)	20 (68)	-100 (-148)
Silicone oil DC 704 (high temperature)	375 (707) @ 1 bar	0.7 (0.5)	220 (428)	-10 (14)
Vegetable oil Neobee M-20 (food - sanitary) FDA approved	200 (390) @ 1 bar	10 (7.2)	20 (68)	-18 (0)
Mineral oil Esso Marcol 122 (food - sanitary) FDA approved	250 (480) @ 630 mbar	0.7 (0.5)	110 (230)	-6 (21)
Glycerin Water 70% (food - sanitary) FDA approved	93 (200) @ 1 bar	1000 (760)	93 (200)	-7 (20)

Flushing ring gasket material	Process limits		
	Pressure (max.)	Temperature	P x T
Garlock	6.9 MPa, 69 bar, 1000 psi	-73 and 204 °C (-100 and 400 °F)	250000 ( °F x psi)
Graphite	2.5 MPa, 25 bar, 362 psi	-100 and 380 °C (-148 and 716 °F)	
PTFE	6 MPa, 60 bar, 870 psi	-100 and 250 °C (-148 and 482 °F)	

### Storage

Models 266XRH	Storage temperature limits
Storage limits	-50 and 85 °C (-58 and 185 °F)
LCD integral display	-40 and 85 °C (-40 and 185 °F)

# Model 266DRH Differential Model 266PRH and 266HRH Gauge Model 266VRH and 266NRH Absolute

## Environmental limits

### Electromagnetic compatibility (EMC)

Comply with EN 61326 and NAMUR NE-21  
Surge immunity level (with surge protector): 4 kV  
(according to IEC 1000-4-5 EN 61000-4-5)

### Pressure equipment directive (PED)

Comply with 97/23/EEC following sound engineering practice (SEP).

### Humidity

Relative humidity: up to 100 %  
Condensing, icing: admissible

### Vibration resistance

Accelerations up to 2 g at frequency up to 1000 Hz  
(according to IEC 60068-2-6)

### Shock resistance

Acceleration: 50 g  
Duration: 11 ms  
(according to IEC 60068-2-27)

### Wet and dust-laden atmospheres

The transmitter is dust and sand tight and protected against immersion effects as defined by EN 60529 (1989) to IP 67 (IP 68 on request) or by NEMA to 4X or by JIS to C0920. IP65 with Harting Han connector.

## Hazardous atmospheres

With or without integral display

---

INTRINSIC SAFETY:

ATEX Europe (code E1) and IEC Ex (code E8) approval

II 1 G Ex ia IIC T6/T5/T4 and

II 1/2 G Ex ia IIC T6/T5/T4; IP67.

II 1 D Ex iaD 20 T85 °C and

II 1/2 D Ex iaD 21 T85 °C; IP67.

NEPSI China (code EY)

Ex ia IIC T4~T6, DIP A20TA, T4~T6.

---

EXPLOSION PROOF:

ATEX Europe (code E2) and IEC Ex (code E9) approval

II 1/2 G Ex d IIC T6 and

II 1/2 D Ex tD A21 T85 °C (–50 °C ≤ Ta ≤ +75 °C); IP67.

NEPSI China (code EZ)

Ex d IIC T6, DIP A21TA, T6.

---

TYPE "N":

ATEX Europe (code E3 ) and IEC Ex (code ER) type examination

II 3 G Ex nL IIC T6/T5/T4 and

II 3 D Ex tD A22 T85 °C; IP67.

NEPSI China (code ES) type examination

Ex nL IIC T4~T6, DIP A22TA, T6.

---

FM Approvals US (code E6) and

FM Approvals Canada (code E4):

– Explosionproof (US): Class I, Div. 1, Groups A, B, C, D

– Explosionproof (Canada): Class I, Div. 1, Groups B, C, D

– Dust ignitionproof : Class II, Div. 1, Groups E, F, G

– Suitable for: Class II, Div. 2, Groups F, G; Class III, Div.1, 2

– Nonincendive: Class I, Div. 2, Groups A, B, C, D

– Intrinsically safe: Class I, II, III, Div. 1, Groups A, B, C, D, E, F, G

Class I, Zone 0 AEx ia IIC T6/T4, Zone 0 (FM US)

Class I, Zone 0 Ex ia IIC T6/T4, Zone 0 (FM Canada)

---

COMBINED ATEX (code EW = E1 + E2 + E3), (code E7 = E1 + E2)

COMBINED ATEX and FM Approvals (code EN = EW + E4 + E6)

---

COMBINED FM Approvals US and Canada

– Intrinsically safe (code EA)

– Explosionproof (code EB)

– Nonincendive (code EC)

---

COMBINED IEC (code EH = E8 + E9), (code EI = E8 + E9 + ER)

COMBINED NEPSI (code EP = EY + EZ), (code EQ = EY + EZ + ES)

---

– GOST (Russia), GOST (Kazakhstan), Inmetro (Brazil)

based on ATEX

---

REFER TO CERTIFICATES FOR AMBIENT TEMPERATURE RANGES (WITHIN THE LIMITS OF -50 TO 85°C) RELATED TO THE DIFFERENT TEMPERATURE CLASSES

## Electrical Characteristics and Options

### HART digital communication and 4 to 20 mA output Power Supply

The transmitter operates from 10.5 to 42 V DC with no load and is protected against reverse polarity connection (additional load allows operations over 42 V DC).

For EEx ia and other intrinsically safe approval power supply must not exceed 30 V DC.

Minimum operating voltage increase to 12.3 V DC with optional surge protector

### Ripple

20 mV max on a 250  $\Omega$  load as per HART specifications.

### Load limitations

4 to 20 mA and HART total loop resistance :

$$R \text{ (k}\Omega\text{)} = \frac{\text{Supply voltage} - \text{min. operating voltage (V DC)}}{22 \text{ mA}}$$

A minimum of 250  $\Omega$  is required for HART communication.

### Optional indicators

#### Integral display (code L1)

Wide screen LCD, 128 x 64 pixel,

52.5 x 27.2 mm (2.06 x 1.07 in.) dot matrix. Multilanguage.

Four keys for configuration and management of device.

Easy setup for quick commissioning.

User selectable application-specific visualizations.

Totalized and instantaneous flow indication.

Display may also indicate static pressure, sensor temperature and diagnostic messages and provides configuration facilities.

#### Through-the-glass (TTG) controlled display (code L5)

As above integral display but equipped with the innovative TTG keypad allowing the activation of the configuration and management menus of the device without the need of removing the transmitter housing cover.

TTG keypad is protected against accidental activations.

### Optional surge protection

Up to 4kV

– voltage 1.2  $\mu$ s rise time / 50  $\mu$ s delay time to half value

– current 8  $\mu$ s rise time / 20  $\mu$ s delay time to half value

### Output signal

Two-wire 4 to 20 mA, user-selectable for linear or square root output, power of  $3/2$  or  $5/2$ , square root for bidirectional flow, 22 points linearization table (i.e. for horizontal or spherical tank level measurement).

HART® communication provides digital process variable superimposed on 4 to 20 mA signal, with protocol based on Bell 202 FSK standard.

### Output current limits (to NAMUR standard)

Overload condition

- Lower limit: 3.8 mA (configurable from 3.8 to 4 mA)

- Upper limit: 20.5 mA (configurable from 20 to 21 mA)

### Alarm current

- Lower limit: 3.6 mA (configurable from 3.6 to 4 mA)

- Upper limit: 21 mA (configurable from 20 to 22 mA)

Factory setting: high alarm current

### Process diagnostics (PILD)

Plugged impulse line detection (PILD) generates a warning via HART communication. The device can also be configured to drive the analog output signal to the "Alarm current".



# Model 266DRH Differential

## Model 266PRH and 266HRH Gauge

## Model 266VRH and 266NRH Absolute

### FOUNDATION Fieldbus output

#### Device type

LINK MASTER DEVICE

Link Active Scheduler (LAS) capability implemented.

Manufacturer code: 000320 (hex)

Device type code: 0007 (hex)

#### Power supply

The transmitter operates from 9 to 32 V DC, polarity independent, with or without surge protector.

For EEx ia approval power supply must not exceed 24 V DC (entity certification) or 17.5 V DC (FISCO certification), according to FF-816.

#### Current consumption

operating (quiescent): 15 mA

fault current limiting: 20 mA max.

#### Output signal

Physical layer in compliance to IEC 1158-2/EN 61158-2 with transmission to Manchester II modulation, at 31.25 kbit/s.

#### Function blocks/execution period

3 enhanced Analog Input blocks/25 ms max (each)

1 enhanced PID block/40 ms max.

1 standard ARithmetic block/25 ms

1 standard Input Selector block/25 ms

1 standard Control Selector block/25 ms

1 standard Signal Characterization block/25 ms

1 standard Integrator/Totalizer block/25 ms

#### Additional blocks

1 enhanced Resource block,

1 custom Pressure with calibration transducer block

1 custom Advanced Diagnostics transducer block including

Plugged Input Line Detection

1 custom Local Display transducer block

#### Number of link objects

35

#### Number of VCRs

35

### Output interface

FOUNDATION fieldbus digital communication protocol to standard H1, compliant to specification V. 1.7.

#### Integral display

Wide screen LCD, 128 x 64 pixel,

52.5 x 27.2 mm (2.06 x 1.07 in.) dot matrix. Multilanguage.

Four keys for configuration and management of device.

Easy setup for quick commissioning.

User selectable application-specific visualizations.

Totalized and instantaneous flow indication.

Display may also indicate static pressure, sensor temperature and diagnostic messages and provides configuration facilities.

#### Transmitter failure mode

The output signal is “frozen” to the last valid value on gross transmitter failure condition, detected by self-diagnostics which also indicate a BAD conditions. If electronic failure or short circuit occur the transmitter consumption is electronically limited at a defined value (20 mA approx), for safety of the network.



## PROFIBUS PA output

### Device type

Pressure transmitter compliant to Profiles 3.0.1  
Identification number: 3450 (hex)

### Power supply

The transmitter operates from 9 to 32 V DC , polarity independent, with or without surge protector.  
For EEx ia approval power supply must not exceed 17.5 V DC.  
Intrinsic safety installation according to FISCO model.

### Current consumption

operating (quiescent): 15 mA  
fault current limiting: 20 mA max.

### Output signal

Physical layer in compliance to IEC 1158–2/EN 61158–2 with transmission to Manchester II modulation, at 31.25 kbit/s.

### Output interface

PROFIBUS PA communication according to Profibus DP50170 Part 2/DIN 19245 part 1–3.

### Output update time

25 ms

### Data blocks

3 analog input, 1 physical.

### Additional blocks

1 Pressure with calibration transducer block  
1 Advanced Diagnostics transducer block including Plugged Input Line Detection  
1 Local Display transducer block

### Integral display

Wide screen LCD, 128 x 64 pixel,  
52.5 x 27.2 mm (2.06 x 1.07 in.) dot matrix. Multilanguage.  
Four keys for configuration and management of device.  
Easy setup for quick commissioning.  
User selectable application-specific visualizations.  
Instantaneous flow indication.  
Display may also indicate static pressure, sensor temperature and diagnostic messages and provides configuration facilities.

### Transmitter failure mode

On gross transmitter failure condition, detected by self-diagnostics, the output signal can be driven to defined conditions, selectable by the user as safe, last valid or calculated value.  
If electronic failure or short circuit occur the transmitter consumption is electronically limited at a defined value (20 mA approx), for safety of the network.

## Performance specifications

Stated at reference condition to IEC 60770 ambient temperature of 20 °C (68 °F), relative humidity of 65 %, atmospheric pressure of 1013 hPa (1013 mbar), mounting position with vertical diaphragm and zero based range for transmitter with isolating diaphragms in AISI 316 L ss or Hastelloy and silicone oil fill and HART digital trim values equal to 4 mA and to 20 mA span end points, in linear mode. Unless otherwise specified, errors are quoted as % of span. Some performance referring to the Upper Range Limit are affected by the actual turndown (TD) as ratio between Upper Range Limit (URL) and calibrated span.

IT IS RECOMMENDED TO SELECT THE TRANSMITTER SENSOR CODE PROVIDING THE TURNDOWN VALUE AS LOWEST AS POSSIBLE TO OPTIMIZE PERFORMANCE CHARACTERISTICS.

### Accuracy rating

% of calibrated span, including combined effects of terminal based linearity, hysteresis and repeatability.  
For fieldbus versions SPAN refer to analog input function block outscale range

Model	Sensor	for TD up to	
266DRH, 266PRH with seals	F and G	from 1:1 to 10:1	± 0.06 %
	F and G	from 10:1 to 60:1	± (0.006 x TD) %
mnemonic	H to S	from 1:1 to 10:1	± 0.075 %
P3, F3, E3, S3, F2	H to S	from 10:1 to 60:1	± (0.0075 x TD) %
	E and B	from 1:1 to 5:1	± 0.10 %
	E and B	from 5:1 to 20:1	± (0.02 x TD) %
266DRH, 266PRH with seals	F to S	from 1:1 to 10:1	± 0.10 %
	F to S	from 10:1 to 60:1	± (0.01 x TD) %
mnemonic different from above	E and B	from 1:1 to 5:1	± 0.15 %
	E and B	from 5:1 to 20:1	± (0.03 x TD) %

# Model 266DRH Differential Model 266PRH and 266HRH Gauge Model 266VRH and 266NRH Absolute

## Accuracy rating

% of calibrated span, including combined effects of terminal based linearity, hysteresis and repeatability.

For fieldbus versions SPAN refer to analog input function block outscale range

Model	Sensor	for TD up to	
266VRH	F to S	from 1:1 to 10:1	± 0.10 %
with seals mnemonic P3, F3, E3, S3, F2	F to S	from 10:1 to 60:1	± (0.01 x TD) %
	E	from 1:1 to 5:1	± 0.10 %
	E	from 5:1 to 20:1	± (0.02 x TD) %
266VRH	F to S	from 1:1 to 10:1	± 0.10 %
with seals mnemonic different from above	F to S	from 10:1 to 60:1	± (0.01 x TD) %
	E	from 1:1 to 5:1	± 0.15 %
	E	from 5:1 to 20:1	± (0.03 x TD) %
266HRH	M and P	from 1:1 to 10:1	± 0.06 %
with seals mnemonic P3, F3, E3, S3, F2	M and P	from 10:1 to 60:1	± (0.006 x TD) %
	G, H, Q,	from 1:1 to 10:1	± 0.075 %
	S, V	from 10:1 to 60:1	± (0.0075 x TD) %
266HRH with seals different from above	G, H, M,	from 1:1 to 10:1	± 0.10 %
	P, Q, S, V	from 10:1 to 60:1	± (0.01 x TD) %
266NRH with seals mne- monic P3, F3, E3, S3, F2	G to S	from 1:1 to 10:1	± 0.10 %
	G to S	from 10:1 to 60:1	± (0.01 x TD) %
266NRH with seals different from above	G to S	from 1:1 to 10:1	± 0.15 %
	G to S	from 10:1 to 60:1	± (0.015 x TD) %

## Ambient temperature

Transmitter effect per 20K change between the limits of -40 °C to +85 °C (per 36 °F change between the limits of -40 to +185 °F):

Model	Sensor	for TD up to	
266DRH, 266PRH	E to S	10 : 1	± (0.04 % URL + 0.065 % span)
266DRH	B	10 : 1	± (0.06 % URL + 0.10 % span)
266VRH	E to S	10 : 1	± (0.08 % URL + 0.13 % span)
266HRH	G to V	10 : 1	± (0.04 % URL + 0.065 % span)
266NDH	G to S	10 : 1	± (0.08 % URL + 0.13 % span)

REFER TO S26 SEALS DATA SHEET FOR TEMPERATURE ADDITIONAL EFFECTS OF REMOTE SEAL(S)

## Static pressure

(zero errors can be calibrated out at line pressure)

per 2 MPa, 20 bar or 290 psi

Model 266DRH with remote seal(s)

– zero error: ±0.25% of URL

– span error: ±0.25% of reading

## Supply voltage

Within voltage/load specified limits the total effect is less than 0.005 % of URL per volt.

## Load

Within load/voltage specified limits the total effect is negligible.

## Electromagnetic field

Meets all the requirements of EN 61326 and NAMUR NE-21.

## Common mode interference

No effect from 100Vrms @ 50Hz, or 50 V DC

## Physical Specification

(Refer to ordering information sheets for variant availability related to specific model or versions code)

### **Model 266DRH only - side without seal materials**

#### **Process isolating diaphragms (\*)**

AISI 316 L ss; Hastelloy C-276™; Monel 400™; Tantalum.  
A remote seal can be selected with required diaphragm material (refer to high pressure side).

#### **Process flanges, adapters, plugs and drain/vent valves (\*)**

AISI 316 L ss; Hastelloy C-276™; Monel 400™.

#### **Bolts and nuts**

AISI 316 ss bolts Class A4–80 and nuts Class A4-70 per UNI 7323 (ISO 3506);

AISI 316 ss bolts and nuts Class A4–50 per UNI 7323 (ISO 3506), in compliance with NACE MR0175 Class II.

#### **Gaskets (\*)**

Viton™; PTFE.

### **Model 266DRH, 266PRH, 266HRH, 266VRH, 266NRH materials**

#### **Seal side process diaphragm (remote seal) (\*)**

AISI 316 L ss; Hastelloy C-276™; Hastelloy C-2000™; Inconel 625; Tantalum; AISI 316 L ss or Hastelloy C-276™ with anti-stick coating; AISI 316 L ss with anti-corrosion coating; AISI 316 L ss gold plated; Superduplex ss (UNS S32750 to ASTM SA479); Diaflex (AISI with anti-abrasion treatment).

#### **Extension material (\*)**

AISI 316 L ss (also for Diaflex and gold plated diaphragms); Hastelloy C-276™; AISI 316 L ss or Hastelloy C-276™ with coating same as diaphragm

#### **Seal side fill fluid (remote seal)**

Silicone oil-DC200™; Silicone oil-DC704™; Inert-Galden™; Inert-Halocarbon™ 4.2; Silicone Polymer-Syltherm XLT™; Low viscosity silicone oil-Baysilone™ M5; Glycerin Water; Vegetable oil-Neobee M-20™; Mineral oil-Esso Marcol 122™.

#### **Sensor fill fluid**

Silicone oil; Inert fill (Halocarbon™ 4.2 or Galden™).

#### **Sensor housing**

AISI 316 L ss.

#### **Electronic housing and covers**

Aluminium alloy (copper content ≤ 0.3 %) with baked epoxy finish (colour RAL9002); AISI 316 L ss.

#### **Covers O-ring**

Buna N.

#### **Mounting bracket (\*\*)**

Zinc plated carbon steel with chrome passivation; AISI 316 ss; AISI 316 L ss.

### **Local adjustments (zero, span and write protect)**

Glass filled polyphenylene oxide (removable).

#### **Plates**

AISI 316ss for transmitter nameplate, certification plate, optional tag/calibration plate attached to the electronics housing and optional wired-on customer data plate. All printing by laser.

#### **Calibration**

Standard: at maximum span, zero based range, ambient temperature and pressure;

Optional: at specified range and ambient conditions.

#### **Optional extras**

##### **Mounting bracket**

For vertical and horizontal 60mm. (2in) pipes or wall mounting.

##### **Display**

4-position (at 90°) user orientable.

##### **Optional plates**

Code I2: for tag (up to 31 characters) and calibration details (up to 31 characters: lower and upper values plus unit) fixed onto transmitter housing.

Code I1: for customer data (32 character x 4 lines) wired-on transmitter housing

##### **Surge protection**

##### **Test Certificates (test, design, calibration, material traceability)**

##### **Tag and manual language**

##### **Communication connectors**

# Model 266DRH Differential

## Model 266PRH and 266HRH Gauge

## Model 266VRH and 266NRH Absolute

### Process connections

on conventional flanges : 1/4 – 18 NPT on process axis  
on adapters : 1/2 – 14 NPT on process axis  
fixing threads: 7/16 – 20 UNF at 41.3mm centre distance  
Refer to S26 seal data sheet for process connection variants  
through remote seal

### Electrical connections

Two 1/2 – 14 NPT or M20x1.5 threaded conduit entries, direct on housing.  
Special communication connector (on request)  
– HART: straight or angle Harting Han 8D connector and one plug.  
– FOUNDATION Fieldbus, PROFIBUS PA: M12x1 or 7/8 in.

### Terminal block

HART version: three terminals for signal/external meter wiring up to 2.5 mm<sup>2</sup> (14 AWG), also connection points for test and communication purposes.  
Fieldbus versions: two terminals for signal wiring (bus connection) up to 2.5 mm<sup>2</sup> (14 AWG)

### Grounding

Internal and external 6 mm<sup>2</sup> (10 AWG) ground termination points are provided.

### Mounting position

Transmitter can be mounted in any position.  
Electronics housing may be rotated to any position. A positive stop prevents over travel.

### Mass (without options and seals)

models 266DRH, 266PRH, 266VRH : 4 kg approx (8.8 lb)  
models 266HRH, 266NRH: 2 kg approx (4.4 lb)  
Add 1.5kg (3.4lb) for AISI housing.  
Add 650g (1.5lb) for packing.  
Consider additional weight up to 50 kg (up to 110 lb) for seals.

### Packing

Carton

(\*) Wetted parts of the transmitter.

(\*\*) U-bolt material: high-strength alloy steel or AISI 316 L ss;  
bolts/nuts material: high-strength alloy steel or AISI 316 ss.

## Configuration

### Transmitter with HART communication and 4 to 20 mA Standard configuration

Transmitters are factory calibrated to customer's specified range. Calibrated range and tag number are stamped on the tag plate. If a calibration range and tag data are not specified, the transmitter will be supplied with the plate left blank and configured as follows:

Engineering Unit	kPa
4 mA	Zero
20 mA	Upper Range Limit (URL)
Output	Linear
Damping	1 s
Transmitter failure mode	Upscale
Software tag (8 characters max)	Blank
Optional LCD display	PV in kPa; output in mA and in percentage on bargraph

Any or all the above configurable parameters, including Lower range-value and Upper range-value which must be the same unit of measure, can be easily changed using the HART hand-held communicator or by a PC running the configuration software with DTM for 266 models. The transmitter database is customized with specified flange type and material, O-ring and drain/vent materials and meter code option.

#### Custom configuration (option N6)

The following data may be specified in addition to the standard configuration parameters:

Descriptor	16 alphanumeric characters
Message	32 alphanumeric characters
Date	Day, month, year

For HART protocol available engineering units of pressure measure are :

Pa, kPa, MPa

inH<sub>2</sub>O@4 °C, mmH<sub>2</sub>O@4 °C, psi

inH<sub>2</sub>O@20 °C, ftH<sub>2</sub>O@20 °C, mmH<sub>2</sub>O@20 °C

inHg, mmHg, Torr

g/cm<sup>2</sup>, kg/cm<sup>2</sup>, atm

mbar, bar

These and others are available for PROFIBUS and FOUNDATION Fieldbus.

### Transmitter with PROFIBUS PA communication Standard configuration

Transmitters are factory calibrated to customer's specified range. Calibrated range and tag number are stamped on the tag plate. If a calibration range and tag data are not specified, the transmitter will be supplied with the plate left blank and configured as follows:

Measure Profile	Pressure
Engineering Unit	kPa
Output scale 0 %	Lower Range Limit (LRL)
Output scale 100 %	Upper Range Limit (URL)
Output	Linear
Hi-Hi Limit	Upper Range Limit (URL)
Hi Limit	Upper Range Limit (URL)
Low Limit	Lower Range Limit (LRL)
Low-Low Limit	Lower Range Limit (LRL)
Limits hysteresis	0.5 % of output scale
PV filter	0 s
Address (set by local key)	126
Tag	32 alphanumeric characters
Optional LCD display	PV in kPa; output in percentage on bargraph

Any or all the above configurable parameters, including the range values which must be the same unit of measure, can be easily changed by a PC running the configuration software with DTM for 266 models. The transmitter database is customized with specified flange type and material, O-ring and drain/vent materials and meter code option.

#### Custom configuration (option N6)

The following data may be specified in addition to the standard configuration parameters:

Descriptor	32 alphanumeric characters
Message	32 alphanumeric characters
Date	Day, month, year

# Model 266DRH Differential

## Model 266PRH and 266HRH Gauge

## Model 266VRH and 266NRH Absolute

### Transmitter with FOUNDATION Fieldbus communication

#### Standard configuration

Transmitters are factory calibrated to customer's specified range. Calibrated range and tag number are stamped on the tag plate. If a calibration range and tag data are not specified, the transmitter will be supplied with the plate left blank and the analog input function block FB1 is configured as follows:

Measure Profile	Pressure
Engineering Unit	kPa
Output scale 0 %	Lower Range Limit (LRL)
Output scale 100 %	Upper Range Limit (URL)
Output	Linear
Hi-Hi Limit	Upper Range Limit (URL)
Hi Limit :	Upper Range Limit (URL)
Low Limit	Lower Range Limit (LRL)
Low-Low Limit	Lower Range Limit (LRL)
Limits hysteresis	0.5 % of output scale
PV filter time	0 s
Tag	32 alphanumeric characters
Optional LCD display	PV in kPa; output in percentage on bargraph

The analog input function block FB2 and FB3 are configured respectively for the sensor temperature measured in °C and for the static pressure measured in MPa.

Any or all the above configurable parameters, including the range values, can be changed using any host compliant to FOUNDATION fieldbus. The transmitter database is customized with specified flange type and material, O-ring and drain/vent materials and meter code option.

#### Custom configuration (option N6)

The following data may be specified in addition to the standard configuration parameters:

Descriptor	32 alphanumeric characters
Message	32 alphanumeric characters
Date	Day, month, year

## MOUNTING DIMENSIONS (not for construction unless certified) – dimensions in mm (in.)

### 266DRH, 266PRH, 266VRH with barrel housing

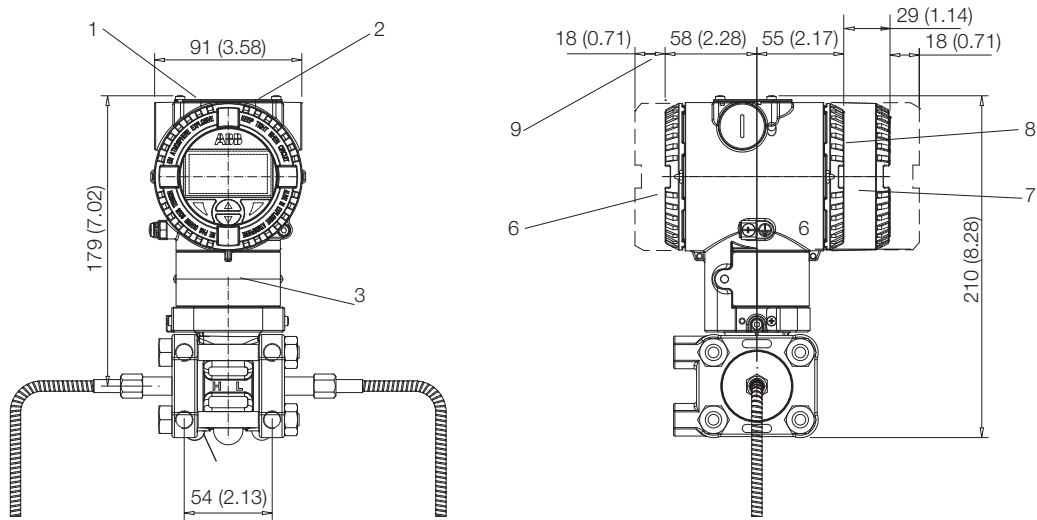

1 Adjustments | 2 Identification plate | 3 Certification plate | 4 Drain/vent valve | 5 Process connection | 6 Terminal side | 7 Integral display housing |  
8 Electronic side | 9 Space for cover removal

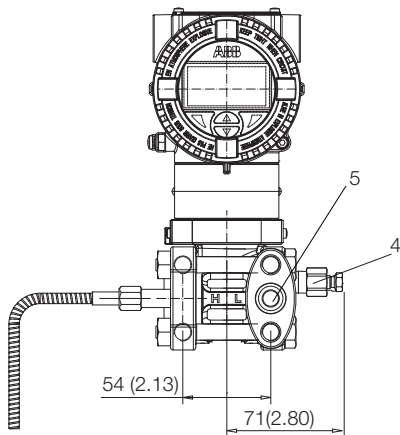

NOTE : For 266DRH using one seal only, the threaded connection (1/4 – 18 NPT direct or 1/2 – 14 NPT through adapter) of conventional flange, gasket groove and gaskets are in accordance with IEC 61518.  
Bolting threads for fixing adapter or other devices (i.e. manifold etc.) on process flange is  $\frac{7}{16}$  – 20 UNF.

# Model 266DRH Differential Model 266PRH and 266HRH Gauge Model 266VRH and 266NRH Absolute

266DRH, 266PRH, 266VRH with barrel housing on bracket for vertical or horizontal 60 mm (2in) pipe

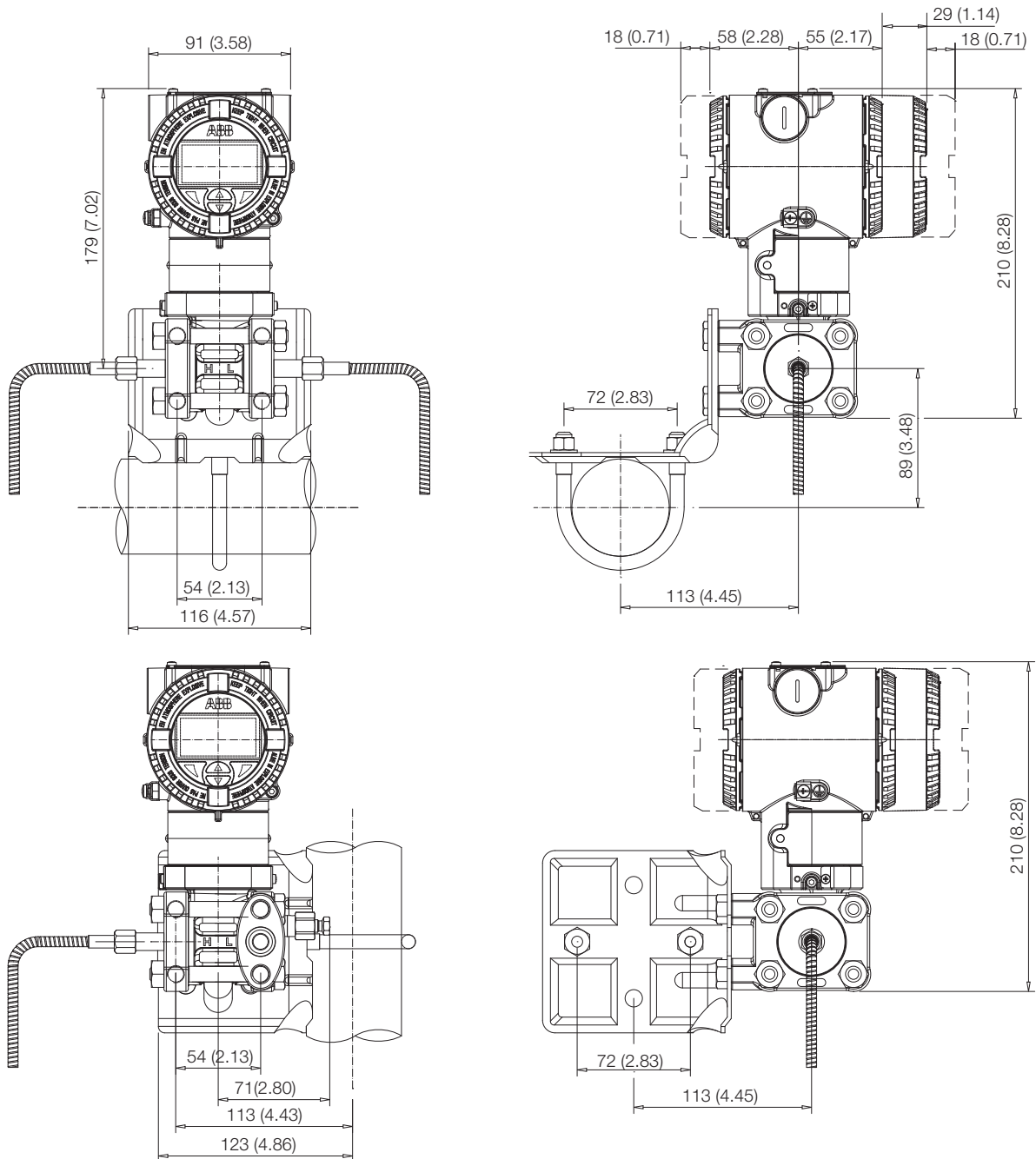



266DRH, 266PRH, 266VRH with DIN housing on bracket for vertical or horizontal 60 mm (2in) pipe

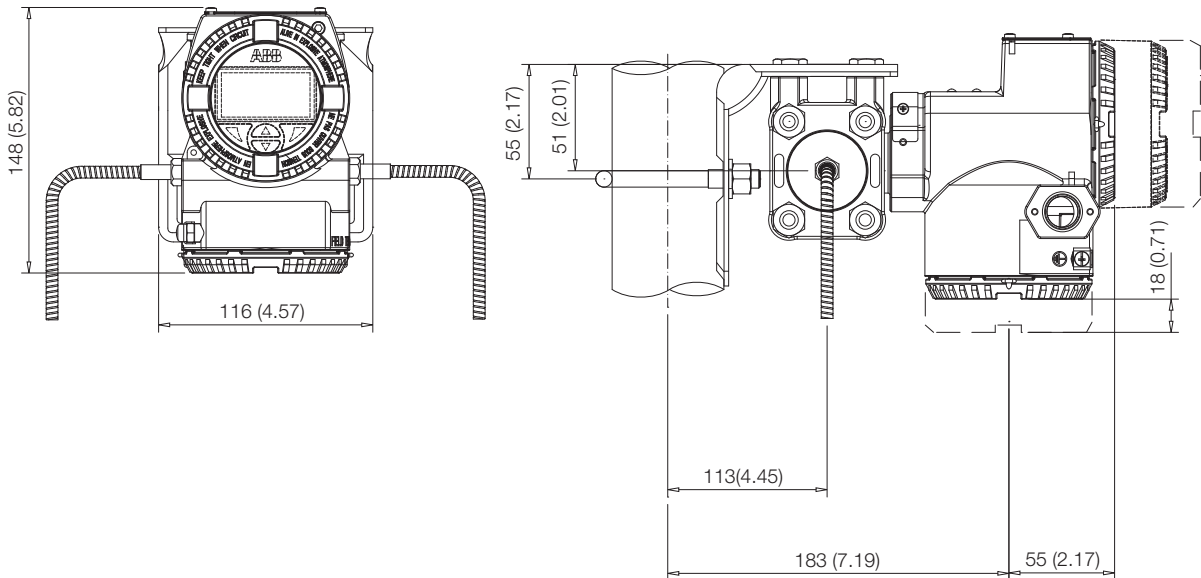
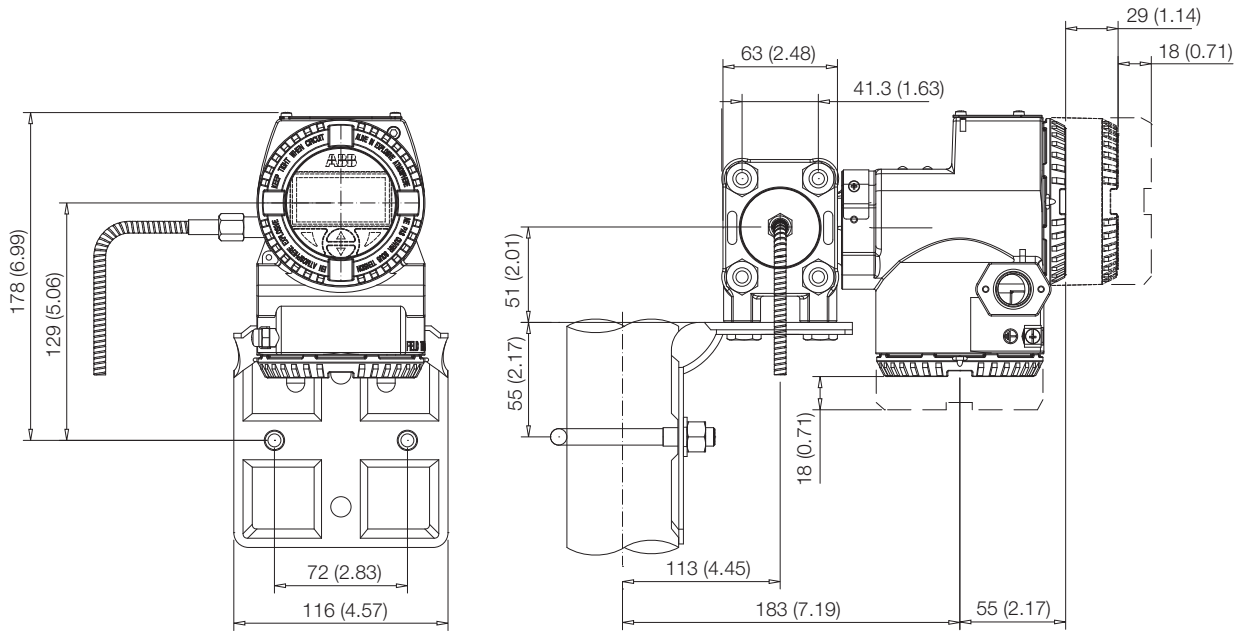

Model 266DRH Differential  
 Model 266PRH and 266HRH Gauge  
 Model 266VRH and 266NRH Absolute

266DRH with barrel housing on flat bracket for vertical or horizontal 60 mm (2in) pipe

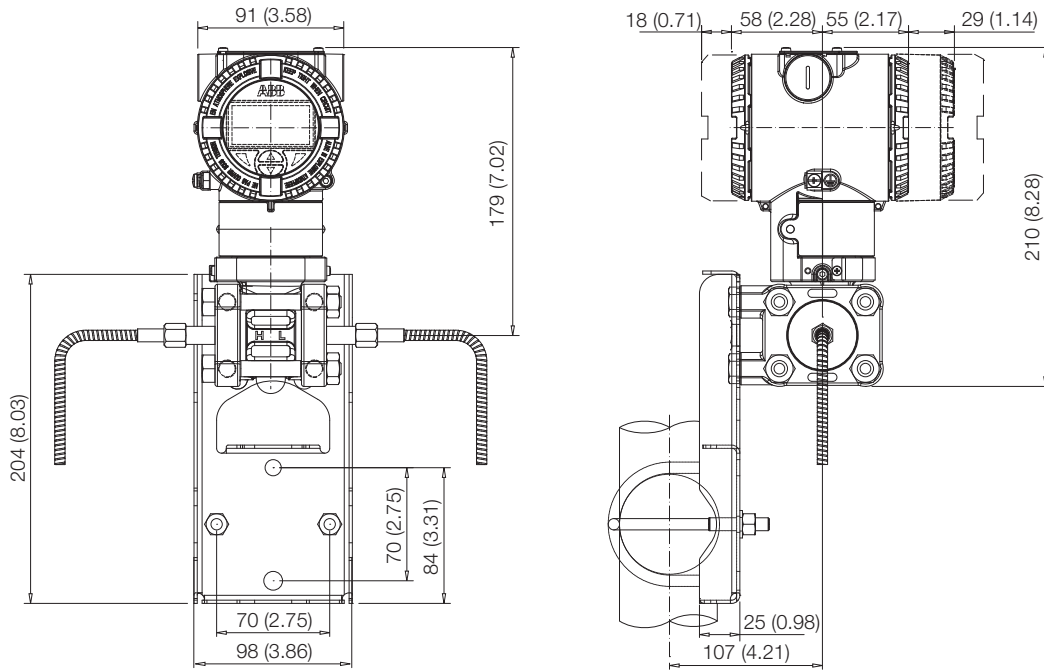

266HRH, 266NRH with barrel housing on bracket for vertical or horizontal 60 mm (2in) pipe - sensors G, H, M, P, Q, S

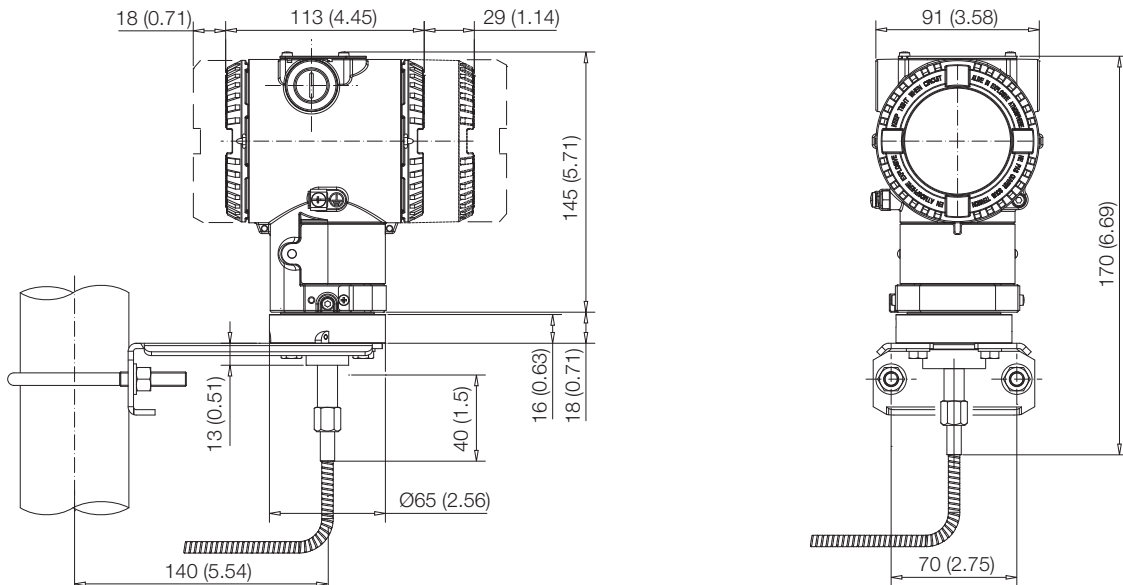

266HRH, 266NRH with barrel housing on bracket for vertical or horizontal 60 mm (2in) pipe - sensor V

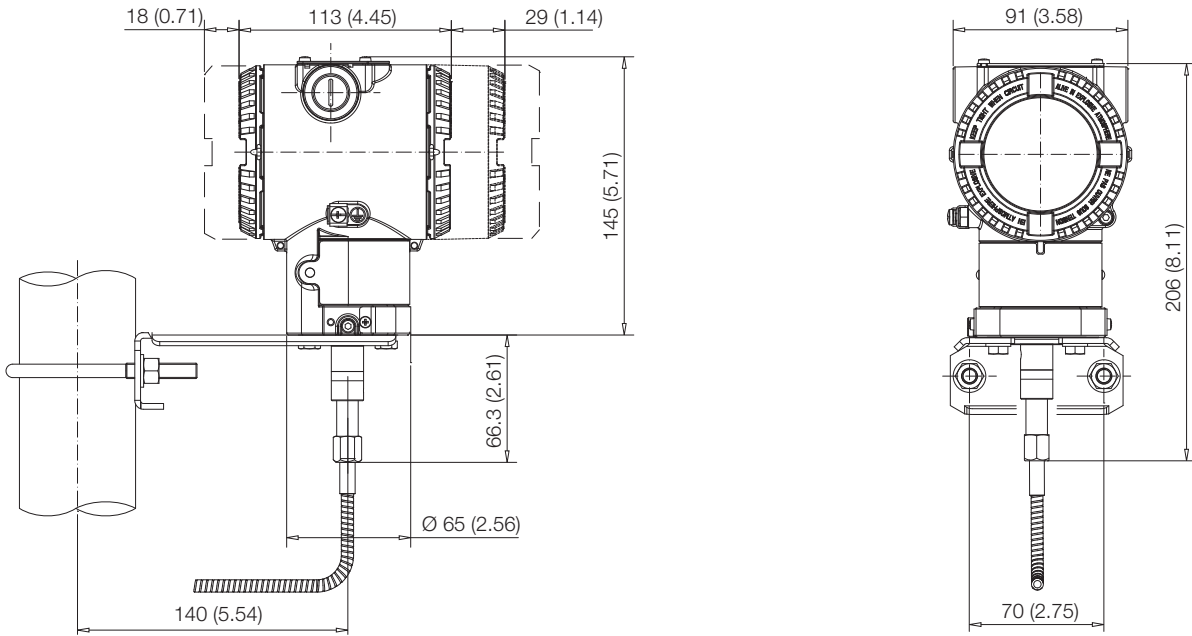

266HRH, 266NRH with DIN housing on bracket for vertical or horizontal 60 mm (2in) pipe - sensors G, H, M, P, Q, S

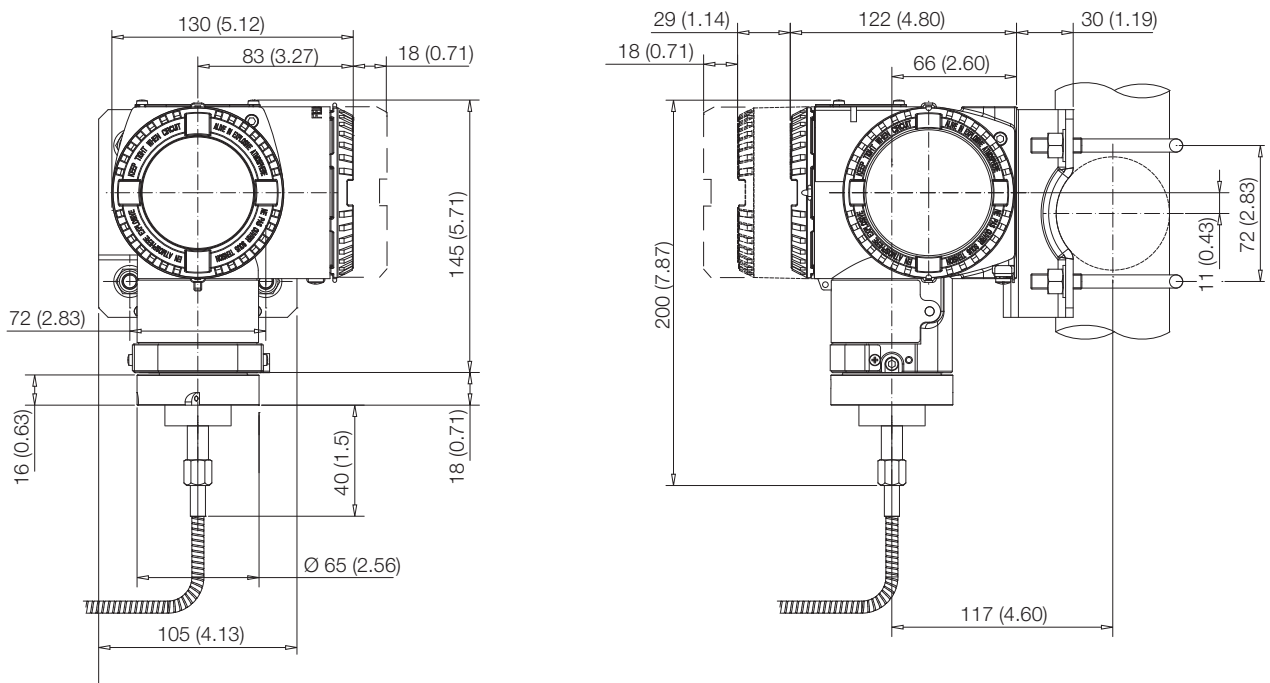

# Model 266DRH Differential Model 266PRH and 266HRH Gauge Model 266VRH and 266NRH Absolute

## Electrical connections

### HART Version

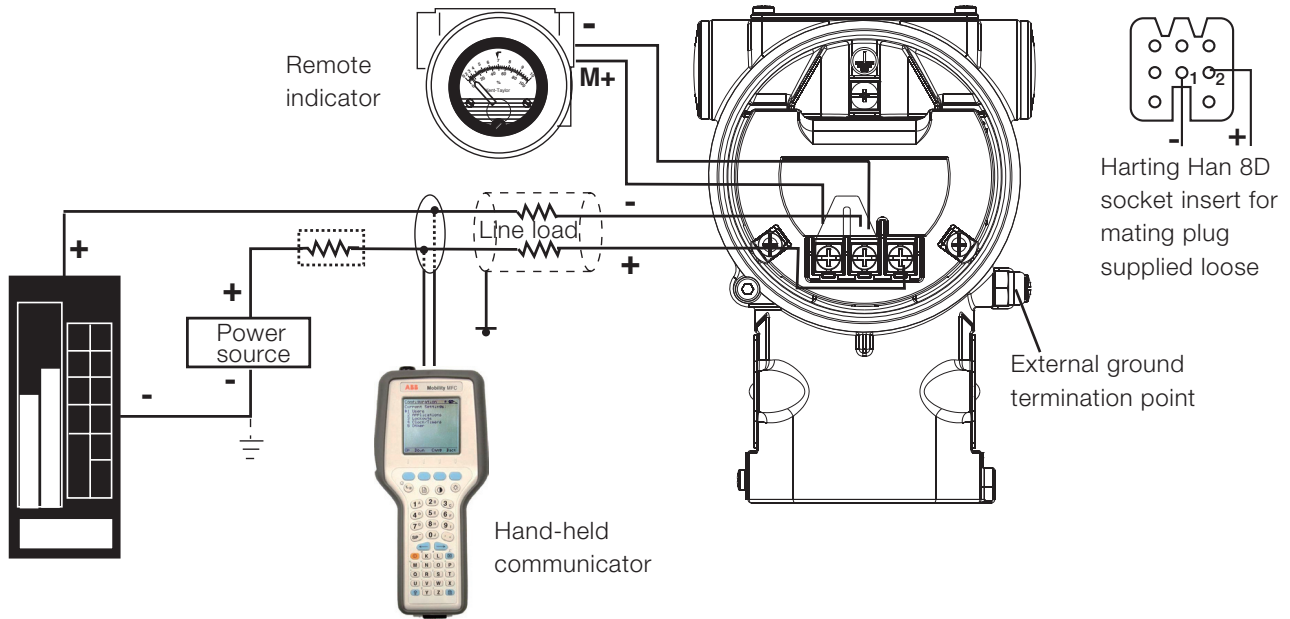

HART hand-held communicator may be connected at any wiring termination point in the loop, providing the minimum resistance is 250 ohm. If this is less than 250 ohm, additional resistance should be added to allow communications.

### FIELDBUS Versions

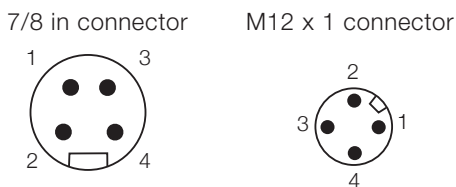

PIN (male) IDENTIFICATION		
	FOUNDATION Fieldbus	PROFIBUS PA
1	DATA -	DATA +
2	DATA +	GROUND
3	SHIELD	DATA -
4	GROUND	SHIELD

CONNECTOR IS SUPPLIED LOOSE  
WITHOUT MATING FEMALE PLUG

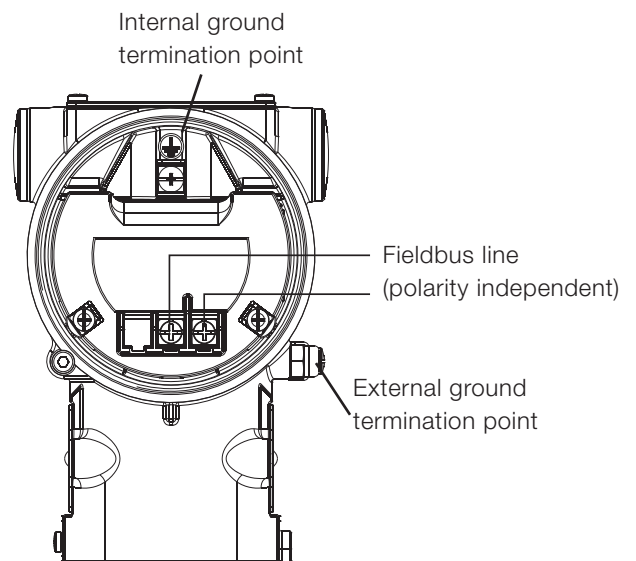

## Ordering information

### BASIC ORDERING INFORMATION model 266DRH Differential Pressure Transmitter with remote seal

Select one character or set of characters from each category and specify complete catalog number.

Refer to additional ordering information and specify one or more codes for each transmitter if additional options are required.

BASE MODEL - 1 <sup>st</sup> to 6 <sup>th</sup> characters				2	6	D	R	H	X	S	X	X	X	X	X
Differential Pressure Transmitter with remote seal- BASE ACCURACY 0.06 %															
<b>SENSOR - Span limits</b> - 7 <sup>th</sup> character															
0.2 and 4 kPa	2 and 40 mbar	0.8 and 16 inH2O							B						
0.8 and 16 kPa	8 and 160 mbar	3.2 and 64 inH2O							E						
0.67 and 40 kPa	6.7 and 400 mbar	2.67 and 160 inH2O							F						
1.1 and 65 kPa	11 and 650 mbar	4.35 and 260 inH2O							G						
2.67 and 160 kPa	26.7 and 1600 mbar	10.7 and 642 inH2O							H						
10 and 600 kPa	0.1 and 6 bar	1.45 and 87 psi							M						
40 and 2400 kPa	0.4 and 24 bar	5.8 and 348 psi							P						
134 and 8000 kPa	1.34 and 80 bar	19.4 and 1160 psi							Q						
267 and 16000 kPa	2.67 and 160 bar	38.7 and 2320 psi							S						
<b>Use code</b> - 8 <sup>th</sup> character															
<b>Diaphragm material / Fill fluid (wetted parts)</b> - 9 <sup>th</sup> character															
AISI 316 L ss	Silicone oil	(one remote seal only to be quoted)	(Note 3)						NACE		S				
Hastelloy C-276™	Silicone oil	(one remote seal only to be quoted)	(Note 3)						NACE		K				
Monel 400™	Silicone oil	(one remote seal only to be quoted)	(Note 3)						NACE		M				
Tantalum	Silicone oil	(one remote seal only to be quoted)	(Note 3)						NACE		T				
AISI 316 L ss	Inert fluid - Galden	(one remote seal only to be quoted)	(Notes 1, 3)						NACE		A				
Hastelloy C-276™	Inert fluid - Galden	(one remote seal only to be quoted)	(Notes 1, 3)						NACE		F				
Monel 400™	Inert fluid - Galden	(one remote seal only to be quoted)	(Notes 1, 3)						NACE		C				
Tantalum	Inert fluid - Galden	(one remote seal only to be quoted)	(Notes 1, 3)						NACE		D				
AISI 316 L ss	Inert fluid - Halocarbon	(one remote seal only to be quoted)	(Notes 1, 3)						NACE		L				
Hastelloy C-276™	Inert fluid - Halocarbon	(one remote seal only to be quoted)	(Notes 1, 3)						NACE		P				
Monel 400™	Inert fluid - Halocarbon	(one remote seal only to be quoted)	(Notes 1, 3)						NACE		4				
Tantalum	Inert fluid - Halocarbon	(one remote seal only to be quoted)	(Notes 1, 3)						NACE		5				
AISI 316 L ss	Silicone oil	(two remote seals to be quoted)	(Note 2)						NACE		R				
AISI 316 L ss	Inert fluid - Galden	(two remote seals to be quoted)	(Notes 1, 3)						NACE		2				
AISI 316 L ss	Inert fluid - Halocarbon	(two remote seals to be quoted)	(Notes 1, 3)						NACE		W				

continued  
see next page

# Model 266DRH Differential Model 266PRH and 266HRH Gauge Model 266VRH and 266NRH Absolute

BASIC ORDERING INFORMATION model 266DRH Differential Pressure Transmitter				2	6	D	R	H	X	S	X	X	X
<b>Process flanges/adapters material and connection (wetted parts) - 10<sup>th</sup> character</b>													
AISI 316 L ss for two seals construction		(Note 4)	NACE						R				
AISI 316 L ss (Horizontal connection)	1/4 – 18 NPT-f direct	(Note 5)	NACE						A				
AISI 316 L ss (Horizontal connection)	1/2 – 14 NPT-f through adapter	(Note 5)	NACE						B				
Hastelloy C-276™ (Horizontal connection)	1/4 – 18 NPT-f direct	(Notes 5, 6)	NACE						D				
Hastelloy C-276™ (Horizontal connection)	1/2 – 14 NPT-f through adapter	(Notes 5, 6)	NACE						E				
Monel 400™ (Horizontal connection)	1/4 – 18 NPT-f direct	(Notes 5, 6)	NACE						G				
Monel 400™ (Horizontal connection)	1/2 – 14 NPT-f through adapter	(Notes 5, 6)	NACE						H				
<b>Bolts/Gasket (wetted parts) - 11<sup>th</sup> character</b>													
AISI 316 ss (NACE) without gaskets for two seals construction – (MWP = 16 MPa)		(Note 4)	NACE								R		
AISI 316 ss without gaskets for two seals construction		(Note 4)									S		
AISI 316 ss	Viton™	(Note 5)									1		
AISI 316 ss	PTFE	(Notes 1, 5)									2		
AISI 316 ss (NACE) – (MWP = 16 MPa)	Viton™	(Note 5)	NACE								3		
AISI 316 ss (NACE) – (MWP = 16 MPa)	PTFE	(Notes 1, 5)	NACE								4		
<b>Housing material and electrical connection - 12<sup>th</sup> character</b>													
Aluminium alloy ( barrel version)	1/2 – 14 NPT												A
Aluminium alloy ( barrel version)	M20 x 1.5 (CM 20)												B
Aluminium alloy ( barrel version)	Harting Han 8D connector	(general purpose only)							(Note 7)				E
Aluminium alloy ( barrel version)	Fieldbus connector	(general purpose only)							(Note 7)				G
AISI 316 L ss ( barrel version)	1/2 – 14 NPT												S
AISI 316 L ss ( barrel version)	M20 x 1.5 (CM20)												T
AISI 316 L ss ( barrel version)	Fieldbus connector	(general purpose only)							(Note 7)				Z
Aluminium alloy (DIN version)	M20 x 1.5 (CM20)	(not Ex d or XP)											J
Aluminium alloy (DIN version)	Harting Han 8D connector	(general purpose only)							(Note 7)				K
Aluminium alloy (DIN version)	Fieldbus connector	(general purpose only)							(Note 7)				W
<b>Output/Additional options - 13<sup>th</sup> character</b>													
HART digital communication and 4 to 20 mA		No additional options							(Notes 8, 9)				H
HART digital communication and 4 to 20 mA		Options requested by “Additional ordering code”							(Note 8)				1
PROFIBUS PA		No additional options							(Notes 8, 9)				P
PROFIBUS PA		Options requested by “Additional ordering code”							(Note 9)				2
FOUNDATION Fieldbus		No additional options							(Notes 8, 9)				F
FOUNDATION Fieldbus		Options requested by “Additional ordering code”							(Note 9)				3
HART and 4 to 20 mA Safety - certified to IEC 61508		No additional options							(Notes 8, 9)				T
HART and 4 to 20 mA Safety - certified to IEC 61508		Options requested by “Additional ordering code”							(Note 8)				8

## ADDITIONAL ORDERING INFORMATION for model 266DRH

Add one or more 2-digit code(s) after the basic ordering information to select all required options

				XX	XX	XX
<b>Drain/vent valve (material and position) (wetted parts)</b>						
AISI 316 L ss	on process axis	(Note 10)	NACE	V1		
AISI 316 L ss	on flange side top	(Note 10)	NACE	V2		
AISI 316 L ss	on flange side bottom	(Note 10)	NACE	V3		
Hastelloy C-276™	on process axis	(Note 11)	NACE	V4		
Hastelloy C-276™	on flange side top	(Note 11)	NACE	V5		
Hastelloy C-276™	on flange side bottom	(Note 11)	NACE	V6		
Monel 400™	on process axis	(Note 12)	NACE	V7		
Monel 400™	on flange side top	(Note 12)	NACE	V8		
Monel 400™	on flange side bottom	(Note 12)	NACE	V9		
<b>Hazardous area certifications</b>						
ATEX Intrinsic Safety II 1 G and II 1/2 G Ex ia IIC T6; II 1 D Ex iaD 20 T 95 °C and II 1/2D Ex iaD 21 T95 °C			(Notes 8, 9)			E1
ATEX Explosion Proof Group II Category 1/2 G Ex d IIC T6 and Group II Category 1/2 D Ex tD A21 IP67 T85 °C			(Notes 8, 9, 13)			E2
ATEX Type „N“ Group II Category 3 G Ex nL IIC T6 and Group II Category 3 D Ex tD A22 IP67 T85 °C			(Notes 8, 9)			E3
Combined ATEX - Intrinsic Safety, Explosion Proof and Type „N“			(Notes 8, 9, 13)			EW
Combined ATEX - Intrinsic Safety and Explosion Proof			(Notes 8, 9, 13)			E7
Combined ATEX, FM Approvals (USA) and FM Approvals (Canada)			(Notes 8, 9, 13)			EN
FM Approvals (Canada) approval			(Notes 8, 9, 13)			E4
FM Approvals (USA) approval			(Notes 8, 9, 13)			E6
FM Approvals (USA and Canada) Intrinsic Safety			(Notes 8, 9)			EA
FM Approvals (USA and Canada) Explosion Proof			(Notes 8, 9, 13)			EB
FM Approvals (USA and Canada) Nonincendive			(Notes 8, 9)			EC
IEC Intrinsic Safety II 1 G and II 1/2 G Ex ia IIC T6; II 1 D Ex iaD 20 T 95 °C and II 1/2D Ex iaD 21 T95 °C;			(Notes 8, 9)			E8
IEC Explosion Proof Group II Category 1/2 G Ex d IIC T6 and Group II Category 1/2 D Ex tD A21 IP67 T85 °C			(Notes 8, 9, 13)			E9
IEC Group II Category 3 G Ex nL IIC T6 and Group II Category 3 D Ex tD A22 IP67 T85 °C			(Notes 8, 9)			ER
Combined IEC - Intrinsic Safety, Explosion Proof and Type „N“			(Notes 8, 9, 13)			EI
Combined IEC - Intrinsic Safety and Explosion Proof			(Notes 8, 9, 13)			EH
NEPSI Intrinsic Safety Ex ia IIC T4~T6, DIP A20TA, T4~T6			(Notes 8, 9)			EY
NEPSI Explosion Proof Ex d IIC T6, DIP A21TA, T6			(Notes 8, 9, 13)			EZ
NEPSI Type „N“ Ex nL IIC T4~T6, DIP A22TA, TT6			(Notes 8, 9)			ES
Combined NEPSI - Intrinsic Safety, Explosion Proof and Type „N“			(Notes 8, 9, 13)			EQ
Combined NEPSI - Intrinsic Safety and Explosion Proof			(Notes 8, 9, 13)			EP
<b>Other hazardous area certifications</b>						
GOST (Russia) EEx ia			(Notes 8, 9)			W1
GOST (Russia) EEx d			(Notes 8, 9, 13)			W2
GOST (Kazakhstan) EEx ia			(Notes 8, 9)			W3
GOST (Kazakhstan) EEx d			(Notes 8, 9, 13)			W4
Inmetro (Brazil) EEx ia			(Notes 8, 9)			W5
Inmetro (Brazil) EEx d			(Notes 8, 9, 13)			W6
Inmetro (Brazil) EEx nL			(Notes 8, 9)			W7
Combined Inmetro (Brazil) - Intrinsic Safety, Explosion Proof and Type „N“			(Notes 8, 9, 13)			W8
<b>Integral LCD</b>						
Digital LCD integral display						L1
TTG (Through-The-Glass) digital LCD controlled display						L5

# Model 266DRH Differential

## Model 266PRH and 266HRH Gauge

## Model 266VRH and 266NRH Absolute

ADDITIONAL ORDERING INFORMATION for model 266DRH		XX	XX	XX	XX	XX	XX
<b>Mounting bracket (shape and material)</b>							
For pipe mounting - Carbon steel	(Not suitable for AISI housing)	B1					
For pipe mounting - AISI 316 L ss	(Not suitable for AISI housing)	B2					
For wall mounting - Carbon steel	(Not suitable for AISI housing)	B3					
For wall mounting - AISI 316 L ss	(Not suitable for AISI housing)	B4					
Flat type for box - AISI 316 ss		B5					
<b>Surge</b>							
Surge/Transient Protector			S2				
<b>Operating manual (up to 2 different selections allowed)</b>							
German (ONLY FOR HART and PROFIBUS VERSIONS)			M1				
Italian (ONLY FOR HART VERSION)			M2				
Spanish (ONLY FOR HART VERSION)			M3				
French (ONLY FOR HART VERSION)			M4				
English			M5				
Chinese (ONLY FOR HART VERSION)			M6				
Swedish (ONLY FOR HART VERSION)			M7				
Polish (ONLY FOR HART VERSION)			M9				
Turkish (ONLY FOR HART VERSION)			MT				
<b>Plates language</b>							
German				T1			
Italian				T2			
Spanish				T3			
French				T4			
<b>Additional tag plate</b>							
Supplemental wired-on stainless steel plate					I1		
Laser printing of tag on stainless steel plate					I2		
<b>Configuration</b>							
Standard – Pressure = inH2O/ psi at 68 °F; Temperature = deg. F						N2	
Standard – Pressure = inH2O/ psi at 39.2 °F; Temperature = deg. F						N3	
Standard – Pressure = inH2O/ psi at 20 °C; Temperature = deg. C						N4	
Standard – Pressure = inH2O/ psi at 4 °C; Temperature = deg. C						N5	
Custom						N6	
<b>Certificates (up to 2 different selections allowed)</b>							
Inspection certificate EN 10204–3.1 of calibration (9-point)							C1
Inspection certificate EN 10204–3.1 of the cleanliness stage							C3
Inspection certificate EN 10204–3.1 of helium leakage test of the sensor module							C4
Inspection certificate EN 10204–3.1 of the pressure test							C5
Certificate of compliance with the order EN 10204–2.1 of instrument design							C6
Overfill protection							C9
Printed record of configured data of transmitter							CG
PMI test of wetted parts							CT



ADDITIONAL ORDERING INFORMATION FOR MODEL 266DRH		XX	XX	XX	XX
<b>Approvals</b>					
GOST (Russia) without Ex	(NOT APPLICABLE WITH ANY HAZARDOUS AREA CERTIFICATION)	Y1			
GOST (Kazakhstan) without Ex	(NOT APPLICABLE WITH ANY HAZARDOUS AREA CERTIFICATION)	Y2			
GOST (Belarus) without Ex	(NOT APPLICABLE WITH ANY HAZARDOUS AREA CERTIFICATION)	Y4			
Chinese pattern without Ex	(NOT APPLICABLE WITH ANY HAZARDOUS AREA CERTIFICATION)	Y5			
DNV approval			YA		
Lloyd approval			YB		
Approval for Custody transfer			YC		
Bureau Veritas approval			YD		
<b>Material traceability</b>					
Certificate of compliance with the order EN 10204–2.1 of process wetted parts					H1
Inspection certificate EN 10204–3.1 of process wetted parts					H3
Test report EN 10204–2.2 of pressure bearing and process wetted parts					H4
<b>Connector</b>					
Fieldbus 7/8 in. (Recommended for FOUNDATION Fieldbus) - (supplied loose without mating female plug)		(Notes 9, 14)			U1
Fieldbus M12x1 (Recommended for PROFIBUS PA) - (supplied loose without mating female plug)		(Notes 9, 14)			U2
Harting Han 8D – straight entry - (supplied loose)		(Notes 8, 14)			U3
Harting Han 8D – angle entry - (supplied loose)		(Notes 8, 14)			U4

Note 1: Suitable for oxygen service

Note 2: Not wetted – Hastelloy C276™ on AISI seat for sensor code B

Note 3: Not wetted – Not available with sensor code B

Note 4: Not available with low side diaphragm code S, K, M, T, A, F, C, D, L, P, 4, 5

Note 5: Not available with low side diaphragm code R, 2, W

Note 6: Not available with diaphragm material/fill fluid code S, A, L

Note 7: Select type in additional ordering code

Note 8: Not available with Housing code G, Z, W

Note 9: Not available with Housing code E, K

Note 10: Not available with Process flanges/adapters code D, E, G, H, R

Note 11: Not available with Process flanges/adapters code A, B, G, H, R

Note 12: Not available with Process flanges/adapters code A, B, D, E, R

Note 13: Not available with Housing code J, K, W

Note 14: Not available with Housing code A, B, S, T, J

### Standard delivery items (can be differently specified by additional ordering code)

- Adapter supplied loose
- Plug on axis (no drain/vent valve)
- General purpose (no electrical certification)
- No display, no mounting bracket, no surge protection
- Multilanguage short-form operating instruction manual and labels in english
- Configuration with kPa and deg. C units
- No test, inspection or material traceability certificates

# Model 266DRH Differential Model 266PRH and 266HRH Gauge Model 266VRH and 266NRH Absolute

## BASIC ORDERING INFORMATION model 266PRH Gauge Pressure Transmitter with remote seal

Select one character or set of characters from each category and specify complete catalog number.

Refer to additional ordering information and specify one or more codes for each transmitter if additional options are required.

BASE MODEL - 1 <sup>st</sup> to 6 <sup>th</sup> characters			2	6	P	R	H	X	S	X	X	X	X	X
Gauge Pressure Transmitter with remote seal- BASE ACCURACY 0.06 %														
SENSOR - Span limits - 7 <sup>th</sup> character														
0.8 and 16 kPa	8 and 160 mbar	3.2 and 64 inH2O							E					
0.67 and 40 kPa	6.7 and 400 mbar	2.67 and 160 inH2O							F					
1.1 and 65 kPa	11 and 650 mbar	4.35 and 260 inH2O							G					
2.67 and 160 kPa	26.7 and 1600 mbar	10.7 and 642 inH2O							H					
10 and 600 kPa	0.1 and 6 bar	1.45 and 87 psi							M					
40 and 2400 kPa	0.4 and 24 bar	5.8 and 348 psi							P					
134 and 8000 kPa	1.34 and 80 bar	19.4 and 1160 psi							Q					
267 and 16000 kPa	2.67 and 160 bar	38.7 and 2320 psi							S					
Use code - 8 <sup>th</sup> character										S				
Diaphragm material / Fill fluid - 9 <sup>th</sup> character														
AISI 316 L ss	Silicone oil								NACE				R	
AISI 316 L ss	Inert fluid - Galden	(Note 1)							NACE				2	
AISI 316 L ss	Inert fluid - Halocarbon	(Note 1)							NACE				W	
Process flanges material and connection - 10 <sup>th</sup> character														
AISI 316 L ss for seal construction	(one remote seal to be quoted)								NACE				R	
Bolts/Gasket - 11 <sup>th</sup> character														
AISI 316 ss (NACE) without gaskets for seal construction – (MWP = 16 MPa)									NACE				R	
AISI 316 ss without gaskets for seal construction													S	
Housing material and electrical connection - 12 <sup>th</sup> character														
Aluminium alloy ( barrel version)	1/2 – 14 NPT													A
Aluminium alloy ( barrel version)	M20 x 1.5 (CM 20)													B
Aluminium alloy ( barrel version)	Harting Han 8D connector	(general purpose only)											(Note 2)	E
Aluminium alloy ( barrel version)	Fieldbus connector	(general purpose only)											(Note 2)	G
AISI 316 L ss ( barrel version)	1/2 – 14 NPT													S
AISI 316 L ss ( barrel version)	M20 x 1.5 (CM20)													T
AISI 316 L ss ( barrel version)	Fieldbus connector	(general purpose only)											(Note 2)	Z
Aluminium alloy (DIN version)	M20 x 1.5 (CM20)	(not Ex d or XP)												J
Aluminium alloy (DIN version)	Harting Han 8D connector	(general purpose only)											(Note 2)	K
Aluminium alloy (DIN version)	Fieldbus connector	(general purpose only)											(Note 2)	W
Output/Additional options - 13 <sup>th</sup> character														
HART digital communication and 4 to 20 mA	No additional options												(Notes 3, 4)	H
HART digital communication and 4 to 20 mA	Options requested by "Additional ordering code"												(Note 3)	1
PROFIBUS PA	No additional options												(Notes 3, 4)	P
PROFIBUS PA	Options requested by "Additional ordering code"												(Note 4)	2
FOUNDATION Fieldbus	No additional options												(Notes 3, 4)	F
FOUNDATION Fieldbus	Options requested by "Additional ordering code"												(Note 4)	3
HART and 4 to 20 mA Safety - certified to IEC 61508	No additional options												(Notes 3, 4)	T
HART and 4 to 20 mA Safety - certified to IEC 61508	Options requested by "Additional ordering code"												(Note 3)	8

## ADDITIONAL ORDERING INFORMATION for model 266PRH

Add one or more 2-digit code(s) after the basic ordering information to select all required options

	XX	XX	XX	XX
<b>Hazardous area certifications</b>				
ATEX Intrinsic Safety II 1 G and II 1/2 G Ex ia IIC T6; II 1 D Ex iaD 20 T 95 °C and II 1/2D Ex iaD 21 T95 °C	(Notes 3, 4)	E1		
ATEX Explosion Proof Group II Category 1/2 G Ex d IIC T6 and Group II Category 1/2 D Ex tD A21 IP67 T85 °C	(Notes 3, 4, 5)	E2		
ATEX Type „N“ Group II Category 3 G Ex nL IIC T6 and Group II Category 3 D Ex tD A22 IP67 T85 °C	(Notes 3, 4)	E3		
Combined ATEX - Intrinsic Safety, Explosion Proof and Type „N“	(Notes 3, 4, 5)	EW		
Combined ATEX - Intrinsic Safety and Explosion Proof	(Notes 3, 4, 5)	E7		
Combined ATEX, FM Approvals (USA) and FM Approvals (Canada)	(Notes 3, 4, 5)	EN		
FM Approvals (Canada) approval	(Notes 3, 4, 5)	E4		
FM Approvals (USA) approval	(Notes 3, 4, 5)	E6		
FM Approvals (USA and Canada) Intrinsic Safety	(Notes 3, 4)	EA		
FM Approvals (USA and Canada) Explosion Proof	(Notes 3, 4, 5)	EB		
FM Approvals (USA and Canada) Nonincendive	(Notes 3, 4)	EC		
IEC Intrinsic Safety II 1 G and II 1/2 G Ex ia IIC T6; II 1 D Ex iaD 20 T 95 °C and II 1/2D Ex iaD 21 T95 °C;	(Notes 3, 4)	E8		
IEC Explosion Proof Group II Category 1/2 G Ex d IIC T6 and Group II Category 1/2 D Ex tD A21 IP67 T85 °C	(Notes 3, 4, 5)	E9		
IEC Group II Category 3 G Ex nL IIC T6 and Group II Category 3 D Ex tD A22 IP67 T85 °C	(Notes 3, 4)	ER		
Combined IEC - Intrinsic Safety, Explosion Proof and Type „N“	(Notes 3, 4, 5)	EI		
Combined IEC - Intrinsic Safety and Explosion Proof	(Notes 3, 4, 5)	EH		
NEPSI Intrinsic Safety Ex ia IIC T4~T6, DIP A20TA, T4~T6	(Notes 3, 4)	EY		
NEPSI Explosion Proof Ex d IIC T6, DIP A21TA, T6	(Notes 3, 4, 5)	EZ		
NEPSI Type „N“ Ex nL IIC T4~T6, DIP A22TA, TT6	(Notes 3, 4)	ES		
Combined NEPSI - Intrinsic Safety, Explosion Proof and Type „N“	(Notes 3, 4, 5)	EQ		
Combined NEPSI - Intrinsic Safety and Explosion Proof	(Notes 3, 4, 5)	EP		
<b>Other hazardous area certifications</b>				
GOST (Russia) EEx ia	(Notes 3, 4)	W1		
GOST (Russia) EEx d	(Notes 3, 4, 5)	W2		
GOST (Kazakhstan) EEx ia	(Notes 3, 4)	W3		
GOST (Kazakhstan) EEx d	(Notes 3, 4, 5)	W4		
Inmetro (Brazil) EEx ia	(Notes 3, 4)	W5		
Inmetro (Brazil) EEx d	(Notes 3, 4, 5)	W6		
Inmetro (Brazil) EEx nL	(Notes 3, 4)	W7		
Combined Inmetro (Brazil) - Intrinsic Safety, Explosion Proof and Type „N“	(Notes 3, 4, 5)	W8		
<b>Integral LCD</b>				
Digital LCD integral display			L1	
TTG (Through-The-Glass) digital LCD controlled display			L5	
<b>Mounting bracket (shape and material)</b>				
For pipe mounting - Carbon steel	(Not suitable for AISI housing)			B1
For pipe mounting - AISI 316 L ss	(Not suitable for AISI housing)			B2
For wall mounting - Carbon steel	(Not suitable for AISI housing)			B3
For wall mounting - AISI 316 L ss	(Not suitable for AISI housing)			B4
Flat type for box - AISI 316 ss				B5
<b>Surge</b>				
Surge/Transient Protector				S2

# Model 266DRH Differential

## Model 266PRH and 266HRH Gauge

## Model 266VRH and 266NRH Absolute

<b>ADDITIONAL ORDERING INFORMATION for model 266PRH</b>	XX	XX	XX	XX	XX
<b>Operating manual (up to 2 different selections allowed)</b>					
German (ONLY FOR HART and PROFIBUS VERSIONS)	M1				
Italian (ONLY FOR HART VERSION)	M2				
Spanish (ONLY FOR HART VERSION)	M3				
French (ONLY FOR HART VERSION)	M4				
English	M5				
Chinese (ONLY FOR HART VERSION)	M6				
Swedish (ONLY FOR HART VERSION)	M7				
Polish (ONLY FOR HART VERSION)	M9				
Turkish (ONLY FOR HART VERSION)	MT				
<b>Plates language</b>					
German		T1			
Italian		T2			
Spanish		T3			
French		T4			
<b>Additional tag plate</b>					
Supplemental wired-on stainless steel plate				I1	
Laser printing of tag on stainless steel plate				I2	
<b>Configuration</b>					
Standard – Pressure = inH2O/ psi at 68 °F; Temperature = deg. F					N2
Standard – Pressure = inH2O/ psi at 39.2 °F; Temperature = deg. F					N3
Standard – Pressure = inH2O/ psi at 20 °C; Temperature = deg. C					N4
Standard – Pressure = inH2O/ psi at 4 °C; Temperature = deg. C					N5
Custom					N6
<b>Certificates (up to 2 different selections allowed)</b>					
Inspection certificate EN 10204–3.1 of calibration (9-point)					C1
Inspection certificate EN 10204–3.1 of the cleanliness stage					C3
Inspection certificate EN 10204–3.1 of helium leakage test of the sensor module					C4
Inspection certificate EN 10204–3.1 of the pressure test					C5
Certificate of compliance with the order EN 10204–2.1 of instrument design					C6
Overfill protection					C9
Printed record of configured data of transmitter					CG
PMI test of wetted parts					CT

ADDITIONAL ORDERING INFORMATION FOR MODEL 266PRH		XX	XX	XX	XX
<b>Approvals</b>					
GOST (Russia) without Ex	(NOT APPLICABLE WITH ANY HAZARDOUS AREA CERTIFICATION)	Y1			
GOST (Kazakhstan) without Ex	(NOT APPLICABLE WITH ANY HAZARDOUS AREA CERTIFICATION)	Y2			
GOST (Belarus) without Ex	(NOT APPLICABLE WITH ANY HAZARDOUS AREA CERTIFICATION)	Y4			
Chinese pattern without Ex	(NOT APPLICABLE WITH ANY HAZARDOUS AREA CERTIFICATION)	Y5			
DNV approval			YA		
Lloyd approval			YB		
Approval for Custody transfer			YC		
Bureau Veritas approval			YD		
<b>Material traceability</b>					
Certificate of compliance with the order EN 10204–2.1 of process wetted parts					H1
Inspection certificate EN 10204–3.1 of process wetted parts					H3
Test report EN 10204–2.2 of pressure bearing and process wetted parts					H4
<b>Connector</b>					
Fieldbus 7/8 in. (Recommended for FOUNDATION Fieldbus) - (supplied loose without mating female plug)		(Notes 4, 6)			U1
Fieldbus M12x1 (Recommended for PROFIBUS PA) - (supplied loose without mating female plug)		(Notes 4, 6)			U2
Harting Han 8D – straight entry - (supplied loose)		(Notes 3, 6)			U3
Harting Han 8D – angle entry - (supplied loose)		(Notes 3, 6)			U4

Note 1: Suitable for oxygen service

Note 2: Select type in additional ordering code

Note 3: Not available with Housing code G, Z, W

Note 4: Not available with Housing code E, K

Note 5: Not available with Housing code J, K, W

Note 6: Not available with Housing code A, B, S, T, J

### Standard delivery items (can be differently specified by additional ordering code)

- General purpose (no electrical certification)
- No display, no mounting bracket, no surge protection
- Multilanguage short-form operating instruction manual and labels in english
- Configuration with kPa and deg. C units
- No test, inspection or material traceability certificates

# Model 266DRH Differential

## Model 266PRH and 266HRH Gauge

## Model 266VRH and 266NRH Absolute

### BASIC ORDERING INFORMATION model 266HRH Gauge Pressure Transmitter with remote seal

Select one character or set of characters from each category and specify complete catalog number.

Refer to additional ordering information and specify one or more codes for each transmitter if additional options are required.

<b>BASE MODEL</b> - 1 <sup>st</sup> to 6 <sup>th</sup> characters			<b>2 6 6 H R H</b>	<b>X</b>	<b>X</b>	<b>X</b>	<b>X</b>	<b>X</b>
Gauge Pressure Transmitter with remote seal – BASE ACCURACY 0.06 %								
<b>SENSOR - Span limits</b> - 7 <sup>th</sup> character								
1.1 and 65 kPa	11 and 650 mbar	4.35 and 260 inH2O		G				
2.67 and 160 kPa	26.7 and 1600 mbar	10.7 and 642 inH2O		H				
10 and 600 kPa	0.1 and 6 bar	1.45 and 87 psi		M				
40 and 2400 kPa	0.4 and 24 bar	5.8 and 348 psi		P				
134 and 8000 kPa	1.34 and 80 bar	19.4 and 1160 psi		Q				
267 and 16000 kPa	2.67 and 160 bar	38.7 and 2320 psi		S				
1000 and 60000 kPa	10 and 600 bar	145 and 8700 psi		V				
<b>Diaphragm material / Fill fluid</b> - 8 <sup>th</sup> character								
AISI 316 L ss		Silicone oil		NACE	R			
AISI 316 L ss		Inert fluid - Galden	(Note 1)	NACE	2			
AISI 316 L ss		Inert fluid - Halocarbon	(Note 1)	NACE	W			
<b>Process connection</b> - 9 <sup>th</sup> character								
Remote seal (except button type)		(one seal to be quoted separately)			R			
Button type remote seal		(one button seal to be quoted separately)	(Note 2)		G			
<b>Housing material and electrical connection</b> - 10 <sup>th</sup> character								
Aluminium alloy ( barrel version)		1/2 – 14 NPT						A
Aluminium alloy ( barrel version)		M20 x 1.5 (CM 20)						B
Aluminium alloy ( barrel version)		Harting Han 8D connector	(general purpose only)		(Note 3)			E
Aluminium alloy ( barrel version)		Fieldbus connector	(general purpose only)		(Note 3)			G
AISI 316 L ss ( barrel version)		1/2 – 14 NPT						S
AISI 316 L ss ( barrel version)		M20 x 1.5 (CM20)						T
AISI 316 L ss ( barrel version)		Fieldbus connector	(general purpose only)		(Note 3)			Z
Aluminium alloy (DIN version)		M20 x 1.5 (CM20)	(not Ex d or XP)					J
Aluminium alloy (DIN version)		Harting Han 8D connector	(general purpose only)		(Note 3)			K
Aluminium alloy (DIN version)		Fieldbus connector	(general purpose only)		(Note 3)			W
<b>Output/Additional options</b> - 11 <sup>th</sup> character								
HART digital communication and 4 to 20 mA		No additional options				(Notes 4, 5)		H
HART digital communication and 4 to 20 mA		Options requested by "Additional ordering code"				(Note 5)		1
PROFIBUS PA		No additional options				(Notes 4, 5)		P
PROFIBUS PA		Options requested by "Additional ordering code"				(Note 5)		2
FOUNDATION Fieldbus		No additional options				(Notes 4, 5)		F
FOUNDATION Fieldbus		Options requested by "Additional ordering code"				(Note 5)		3
HART and 4 to 20 mA Safety - certified to IEC 61508		No additional options				(Notes 4, 5)		T
HART and 4 to 20 mA Safety - certified to IEC 61508		Options requested by "Additional ordering code"				(Note 4)		8

## ADDITIONAL ORDERING INFORMATION for model 266HRH

Add one or more 2-digit code(s) after the basic ordering information to select all required options

	XX	XX	XX	XX
<b>Hazardous area certifications</b>				
ATEX Intrinsic Safety II 1 G and II 1/2 G Ex ia IIC T6; II 1 D Ex iaD 20 T 95 °C and II 1/2D Ex iaD 21 T95 °C	(Notes 4, 5)	E1		
ATEX Explosion Proof Group II Category 1/2 G Ex d IIC T6 and Group II Category 1/2 D Ex tD A21 IP67 T85 °C	(Notes 4, 5, 6)	E2		
ATEX Type „N“ Group II Category 3 G Ex nL IIC T6 and Group II Category 3 D Ex tD A22 IP67 T85 °C	(Notes 4, 5)	E3		
Combined ATEX - Intrinsic Safety, Explosion Proof and Type „N“	(Notes 4, 5, 6)	EW		
Combined ATEX - Intrinsic Safety and Explosion Proof	(Notes 4, 5, 6)	E7		
Combined ATEX, FM Approvals (USA) and FM Approvals (Canada)	(Notes 4, 5, 6)	EN		
FM Approvals (Canada) approval	(Notes 4, 5, 6)	E4		
FM Approvals (USA) approval	(Notes 4, 5, 6)	E6		
FM Approvals (USA and Canada) Intrinsic Safety	(Notes 4, 5)	EA		
FM Approvals (USA and Canada) Explosion Proof	(Notes 4, 5, 6)	EB		
FM Approvals (USA and Canada) Nonincendive	(Notes 4, 5)	EC		
IEC Intrinsic Safety II 1 G and II 1/2 G Ex ia IIC T6; II 1 D Ex iaD 20 T 95 °C and II 1/2D Ex iaD 21 T95 °C;	(Notes 4, 5)	E8		
IEC Explosion Proof Group II Category 1/2 G Ex d IIC T6 and Group II Category 1/2 D Ex tD A21 IP67 T85 °C	(Notes 4, 5, 6)	E9		
IEC Group II Category 3 G Ex nL IIC T6 and Group II Category 3 D Ex tD A22 IP67 T85 °C	(Notes 4, 5)	ER		
Combined IEC - Intrinsic Safety, Explosion Proof and Type „N“	(Notes 4, 5, 6)	EI		
Combined IEC - Intrinsic Safety and Explosion Proof	(Notes 4, 5, 6)	EH		
NEPSI Intrinsic Safety Ex ia IIC T4~T6, DIP A20TA, T4~T6	(Notes 4, 5)	EY		
NEPSI Explosion Proof Ex d IIC T6, DIP A21TA, T6	(Notes 4, 5, 6)	EZ		
NEPSI Type „N“ Ex nL IIC T4~T6, DIP A22TA, TT6	(Notes 4, 5)	ES		
Combined NEPSI - Intrinsic Safety, Explosion Proof and Type „N“	(Notes 4, 5, 6)	EQ		
Combined NEPSI - Intrinsic Safety and Explosion Proof	(Notes 4, 5, 6)	EP		
<b>Other hazardous area certifications</b>				
GOST (Russia) EEx ia	(Notes 4, 5)	W1		
GOST (Russia) EEx d	(Notes 4, 5, 6)	W2		
GOST (Kazakhstan) EEx ia	(Notes 4, 5)	W3		
GOST (Kazakhstan) EEx d	(Notes 4, 5, 6)	W4		
Inmetro (Brazil) EEx ia	(Notes 4, 5)	W5		
Inmetro (Brazil) EEx d	(Notes 4, 5, 6)	W6		
Inmetro (Brazil) EEx nL	(Notes 4, 5)	W7		
Combined Inmetro (Brazil) - Intrinsic Safety, Explosion Proof and Type „N“	(Notes 4, 5, 6)	W8		
<b>Integral LCD</b>				
Digital LCD integral display			L1	
TTG (Through-The-Glass) digital LCD controlled display			L5	
<b>Mounting bracket (shape and material)</b>				
For pipe/wall mounting - Carbon steel	(Not suitable for AISI housing)			B1
For pipe/wall mounting - AISI 316 L ss				B2
<b>Surge</b>				
Surge/Transient Protector				S2

# Model 266DRH Differential

## Model 266PRH and 266HRH Gauge

## Model 266VRH and 266NRH Absolute

<b>ADDITIONAL ORDERING INFORMATION for model 266HRH</b>	<b>XX</b>	<b>XX</b>	<b>XX</b>	<b>XX</b>	<b>XX</b>
<b>Operating manual (up to 2 different selections allowed)</b>					
German (ONLY FOR HART and PROFIBUS VERSIONS)	M1				
Italian (ONLY FOR HART VERSION)	M2				
Spanish (ONLY FOR HART VERSION)	M3				
French (ONLY FOR HART VERSION)	M4				
English	M5				
Chinese (ONLY FOR HART VERSION)	M6				
Swedish (ONLY FOR HART VERSION)	M7				
Polish (ONLY FOR HART VERSION)	M9				
Turkish (ONLY FOR HART VERSION)	MT				
<b>Plates language</b>					
German		T1			
Italian		T2			
Spanish		T3			
French		T4			
<b>Additional tag plate</b>					
Supplemental wired-on stainless steel plate				I1	
Laser printing of tag on stainless steel plate				I2	
<b>Configuration</b>					
Standard – Pressure = inH2O/ psi at 68 °F; Temperature = deg. F					N2
Standard – Pressure = inH2O/ psi at 39.2 °F; Temperature = deg. F					N3
Standard – Pressure = inH2O/ psi at 20 °C; Temperature = deg. C					N4
Standard – Pressure = inH2O/ psi at 4 °C; Temperature = deg. C					N5
Custom					N6
<b>Certificates (up to 2 different selections allowed)</b>					
Inspection certificate EN 10204–3.1 of calibration (9-point)					C1
Inspection certificate EN 10204–3.1 of the cleanliness stage					C3
Inspection certificate EN 10204–3.1 of helium leakage test of the sensor module					C4
Inspection certificate EN 10204–3.1 of the pressure test					C5
Certificate of compliance with the order EN 10204–2.1 of instrument design					C6
Overfill protection					C9
Printed record of configured data of transmitter					CG
PMI test of wetted parts					CT



ADDITIONAL ORDERING INFORMATION FOR MODEL 266HRH			XX	XX	XX	XX
<b>Approvals</b>						
GOST (Russia) without Ex	(NOT APPLICABLE WITH ANY HAZARDOUS AREA CERTIFICATION)	Y1				
GOST (Kazakhstan) without Ex	(NOT APPLICABLE WITH ANY HAZARDOUS AREA CERTIFICATION)	Y2				
GOST (Belarus) without Ex	(NOT APPLICABLE WITH ANY HAZARDOUS AREA CERTIFICATION)	Y4				
Chinese pattern without Ex	(NOT APPLICABLE WITH ANY HAZARDOUS AREA CERTIFICATION)	Y5				
DNV approval					YA	
Lloyd approval					YB	
Approval for Custody transfer					YC	
Bureau Veritas approval					YD	
<b>Material traceability</b>						
Certificate of compliance with the order EN 10204–2.1 of process wetted parts						H1
Inspection certificate EN 10204–3.1 of process wetted parts						H3
Test report EN 10204–2.2 of pressure bearing and process wetted parts						H4
<b>Connector</b>						
Fieldbus 7/8 in. (Recommended for FOUNDATION Fieldbus) - (supplied loose without mating female plug)		(Notes 5, 7)				U1
Fieldbus M12x1 (Recommended for PROFIBUS PA) - (supplied loose without mating female plug)		(Notes 5, 7)				U2
Harting Han 8D – straight entry - (supplied loose)		(Notes 4, 7)				U3
Harting Han 8D – angle entry - (supplied loose)		(Notes 4, 7)				U4

Note 1: Suitable for oxygen service - NOT AVAILABLE FOR SENSOR CODE V

Note 2: Not available with Sensor code G, H, M, P

Note 3: Select type in additional ordering code

Note 4: Not available with Housing code G, Z, W

Note 5: Not available with Housing code E, K

Note 6: Not available with Housing code J, K, W

Note 7: Not available with Housing code A, B, S, T, J

### Standard delivery items (can be differently specified by additional ordering code)

- General purpose (no electrical certification)
- No display, no mounting bracket, no surge protection
- Multilanguage short-form operating instruction manual and labels in english
- Configuration with kPa and deg. C units
- No test, inspection or material traceability certificates

# Model 266DRH Differential

## Model 266PRH and 266HRH Gauge

## Model 266VRH and 266NRH Absolute

### BASIC ORDERING INFORMATION model 266VRH Absolute Pressure Transmitter with remote seal

Select one character or set of characters from each category and specify complete catalog number.

Refer to additional ordering information and specify one or more codes for each transmitter if additional options are required.

BASE MODEL - 1 <sup>st</sup> to 6 <sup>th</sup> characters			2	6	V	R	H	X	S	X	X	X	X	X
Gauge Pressure Transmitter with remote seal- BASE ACCURACY 0.10 %														
<b>SENSOR - Span limits</b> - 7 <sup>th</sup> character														
0.8 and 16 kPa	8 and 160 mbar	6 and 120 mmHg						E						
0.67 and 40 kPa	6.7 and 400 mbar	5 and 300 mmHg						F						
1.1 and 65 kPa	11 and 650 mbar	8 and 480 mmHg						G						
2.67 and 160 kPa	26.7 and 1600 mbar	20 and 1200 mmHg						H						
10 and 600 kPa	0.1 and 6 bar	1.45 and 87 psi						M						
40 and 2400 kPa	0.4 and 24 bar	5.8 and 348 psi						P						
134 and 8000 kPa	1.34 and 80 bar	19.4 and 1160 psi						Q						
267 and 16000 kPa	2.67 and 160 bar	38.7 and 2320 psi						S						
<b>Use code</b> - 8 <sup>th</sup> character									S					
<b>Diaphragm material / Fill fluid</b> - 9 <sup>th</sup> character														
AISI 316 L ss	Silicone oil							NACE		R				
AISI 316 L ss	Inert fluid - Galden	(Note 1)						NACE		2				
AISI 316 L ss	Inert fluid - Halocarbon	(Note 1)						NACE		W				
<b>Process flanges/adapters material and connection</b> - 10 <sup>th</sup> character														
AISI 316 L ss for seal construction	(one remote seal to be quoted)							NACE				R		
<b>Bolts/Gasket</b> - 11 <sup>th</sup> character														
AISI 316 ss (NACE) without gaskets for seal construction – (MWP = 16 MPa)								NACE					R	
AISI 316 ss without gaskets for seal construction													S	
<b>Housing material and electrical connection</b> - 12 <sup>th</sup> character														
Aluminium alloy ( barrel version)	1/2 – 14 NPT													A
Aluminium alloy ( barrel version)	M20 x 1.5 (CM 20)													B
Aluminium alloy ( barrel version)	Harting Han 8D connector	(general purpose only)								(Note 2)				E
Aluminium alloy ( barrel version)	Fieldbus connector	(general purpose only)								(Note 2)				G
AISI 316 L ss ( barrel version)	1/2 – 14 NPT													S
AISI 316 L ss ( barrel version)	M20 x 1.5 (CM20)													T
AISI 316 L ss ( barrel version)	Fieldbus connector	(general purpose only)								(Note 2)				Z
Aluminium alloy (DIN version)	M20 x 1.5 (CM20)	(not Ex d or XP)												J
Aluminium alloy (DIN version)	Harting Han 8D connector	(general purpose only)								(Note 2)				K
Aluminium alloy (DIN version)	Fieldbus connector	(general purpose only)								(Note 2)				W
<b>Output/Additional options</b> - 13 <sup>th</sup> character														
HART digital communication and 4 to 20 mA	No additional options									(Notes 3, 4)				H
HART digital communication and 4 to 20 mA	Options requested by "Additional ordering code"									(Note 3)				1
PROFIBUS PA	No additional options									(Notes 3, 4)				P
PROFIBUS PA	Options requested by "Additional ordering code"									(Note 4)				2
FOUNDATION Fieldbus	No additional options									(Notes 3, 4)				F
FOUNDATION Fieldbus	Options requested by "Additional ordering code"									(Note 4)				3
HART and 4 to 20 mA Safety - certified to IEC 61508	No additional options									(Notes 3, 4)				T
HART and 4 to 20 mA Safety - certified to IEC 61508	Options requested by "Additional ordering code"									(Note 3)				8

## ADDITIONAL ORDERING INFORMATION for model 266VRH

Add one or more 2-digit code(s) after the basic ordering information to select all required options

	XX	XX	XX	XX
<b>Hazardous area certifications</b>				
ATEX Intrinsic Safety II 1 G and II 1/2 G Ex ia IIC T6; II 1 D Ex iaD 20 T 95 °C and II 1/2D Ex iaD 21 T95 °C	(Notes 3, 4)	E1		
ATEX Explosion Proof Group II Category 1/2 G Ex d IIC T6 and Group II Category 1/2 D Ex tD A21 IP67 T85 °C	(Notes 3, 4, 5)	E2		
ATEX Type „N“ Group II Category 3 G Ex nL IIC T6 and Group II Category 3 D Ex tD A22 IP67 T85 °C	(Notes 3, 4)	E3		
Combined ATEX - Intrinsic Safety, Explosion Proof and Type „N“	(Notes 3, 4, 5)	EW		
Combined ATEX - Intrinsic Safety and Explosion Proof	(Notes 3, 4, 5)	E7		
Combined ATEX, FM Approvals (USA) and FM Approvals (Canada)	(Notes 3, 4, 5)	EN		
FM Approvals (Canada) approval	(Notes 3, 4, 5)	E4		
FM Approvals (USA) approval	(Notes 3, 4, 5)	E6		
FM Approvals (USA and Canada) Intrinsic Safety	(Notes 3, 4)	EA		
FM Approvals (USA and Canada) Explosion Proof	(Notes 3, 4, 5)	EB		
FM Approvals (USA and Canada) Nonincendive	(Notes 3, 4)	EC		
IEC Intrinsic Safety II 1 G and II 1/2 G Ex ia IIC T6; II 1 D Ex iaD 20 T 95 °C and II 1/2D Ex iaD 21 T95 °C;	(Notes 3, 4)	E8		
IEC Explosion Proof Group II Category 1/2 G Ex d IIC T6 and Group II Category 1/2 D Ex tD A21 IP67 T85 °C	(Notes 3, 4, 5)	E9		
IEC Group II Category 3 G Ex nL IIC T6 and Group II Category 3 D Ex tD A22 IP67 T85 °C	(Notes 3, 4)	ER		
Combined IEC - Intrinsic Safety, Explosion Proof and Type „N“	(Notes 3, 4, 5)	EI		
Combined IEC - Intrinsic Safety and Explosion Proof	(Notes 3, 4, 5)	EH		
NEPSI Intrinsic Safety Ex ia IIC T4~T6, DIP A20TA, T4~T6	(Notes 3, 4)	EY		
NEPSI Explosion Proof Ex d IIC T6, DIP A21TA, T6	(Notes 3, 4, 5)	EZ		
NEPSI Type „N“ Ex nL IIC T4~T6, DIP A22TA, TT6	(Notes 3, 4)	ES		
Combined NEPSI - Intrinsic Safety, Explosion Proof and Type „N“	(Notes 3, 4, 5)	EQ		
Combined NEPSI - Intrinsic Safety and Explosion Proof	(Notes 3, 4, 5)	EP		
<b>Other hazardous area certifications</b>				
GOST (Russia) EEx ia	(Notes 3, 4)	W1		
GOST (Russia) EEx d	(Notes 3, 4, 5)	W2		
GOST (Kazakhstan) EEx ia	(Notes 3, 4)	W3		
GOST (Kazakhstan) EEx d	(Notes 3, 4, 5)	W4		
Inmetro (Brazil) EEx ia	(Notes 3, 4)	W5		
Inmetro (Brazil) EEx d	(Notes 3, 4, 5)	W6		
Inmetro (Brazil) EEx nL	(Notes 3, 4)	W7		
Combined Inmetro (Brazil) - Intrinsic Safety, Explosion Proof and Type „N“	(Notes 3, 4, 5)	W8		
<b>Integral LCD</b>				
Digital LCD integral display			L1	
TTG (Through-The-Glass) digital LCD controlled display			L5	
<b>Mounting bracket (shape and material)</b>				
For pipe mounting - Carbon steel	(Not suitable for AISI housing)			B1
For pipe mounting - AISI 316 L ss	(Not suitable for AISI housing)			B2
For wall mounting - Carbon steel	(Not suitable for AISI housing)			B3
For wall mounting - AISI 316 L ss	(Not suitable for AISI housing)			B4
Flat type for box - AISI 316 ss				B5
<b>Surge</b>				
Surge/Transient Protector				S2

# Model 266DRH Differential

## Model 266PRH and 266HRH Gauge

## Model 266VRH and 266NRH Absolute

<b>ADDITIONAL ORDERING INFORMATION for model 266VRH</b>	<b>XX</b>	<b>XX</b>	<b>XX</b>	<b>XX</b>	<b>XX</b>
<b>Operating manual (up to 2 different selections allowed)</b>					
German (ONLY FOR HART and PROFIBUS VERSIONS)	M1				
Italian (ONLY FOR HART VERSION)	M2				
Spanish (ONLY FOR HART VERSION)	M3				
French (ONLY FOR HART VERSION)	M4				
English	M5				
Chinese (ONLY FOR HART VERSION)	M6				
Swedish (ONLY FOR HART VERSION)	M7				
Polish (ONLY FOR HART VERSION)	M9				
Turkish (ONLY FOR HART VERSION)	MT				
<b>Plates language</b>					
German		T1			
Italian		T2			
Spanish		T3			
French		T4			
<b>Additional tag plate</b>					
Supplemental wired-on stainless steel plate				I1	
Laser printing of tag on stainless steel plate				I2	
<b>Configuration</b>					
Standard – Pressure = inH2O/ psi at 68 °F; Temperature = deg. F					N2
Standard – Pressure = inH2O/ psi at 39.2 °F; Temperature = deg. F					N3
Standard – Pressure = inH2O/ psi at 20 °C; Temperature = deg. C					N4
Standard – Pressure = inH2O/ psi at 4 °C; Temperature = deg. C					N5
Custom					N6
<b>Certificates (up to 2 different selections allowed)</b>					
Inspection certificate EN 10204–3.1 of calibration (9-point)					C1
Inspection certificate EN 10204–3.1 of the cleanliness stage					C3
Inspection certificate EN 10204–3.1 of helium leakage test of the sensor module					C4
Inspection certificate EN 10204–3.1 of the pressure test					C5
Certificate of compliance with the order EN 10204–2.1 of instrument design					C6
Overfill protection					C9
Printed record of configured data of transmitter					CG
PMI test of wetted parts					CT

ADDITIONAL ORDERING INFORMATION FOR MODEL 266VRH			XX	XX	XX	XX
<b>Approvals</b>						
GOST (Russia) without Ex	(NOT APPLICABLE WITH ANY HAZARDOUS AREA CERTIFICATION)		Y1			
GOST (Kazakhstan) without Ex	(NOT APPLICABLE WITH ANY HAZARDOUS AREA CERTIFICATION)		Y2			
GOST (Belarus) without Ex	(NOT APPLICABLE WITH ANY HAZARDOUS AREA CERTIFICATION)		Y4			
Chinese pattern without Ex	(NOT APPLICABLE WITH ANY HAZARDOUS AREA CERTIFICATION)		Y5			
DNV approval				YA		
Lloyd approval				YB		
Approval for Custody transfer				YC		
Bureau Veritas approval				YD		
<b>Material traceability</b>						
Certificate of compliance with the order EN 10204–2.1 of process wetted parts						H1
Inspection certificate EN 10204–3.1 of process wetted parts						H3
Test report EN 10204–2.2 of pressure bearing and process wetted parts						H4
<b>Connector</b>						
Fieldbus 7/8 in. (Recommended for FOUNDATION Fieldbus) - (supplied loose without mating female plug)			(Notes 4, 6)			U1
Fieldbus M12x1 (Recommended for PROFIBUS PA) - (supplied loose without mating female plug)			(Notes 4, 6)			U2
Harting Han 8D – straight entry - (supplied loose)			(Notes 3, 6)			U3
Harting Han 8D – angle entry - (supplied loose)			(Notes 3, 6)			U4

Note 1: Suitable for oxygen service

Note 2: Select type in additional ordering code

Note 3: Not available with Housing code G, Z, W

Note 4: Not available with Housing code E, K

Note 5: Not available with Housing code J, K, W

Note 6: Not available with Housing code A, B, S, T, J

### Standard delivery items (can be differently specified by additional ordering code)

- General purpose (no electrical certification)
- No display, no mounting bracket, no surge protection
- Multilanguage short-form operating instruction manual and labels in english
- Configuration with kPa and deg. C units
- No test, inspection or material traceability certificates

# Model 266DRH Differential

## Model 266PRH and 266HRH Gauge

## Model 266VRH and 266NRH Absolute

### BASIC ORDERING INFORMATION model 266NRH Absolute Pressure Transmitter with remote seal

Select one character or set of characters from each category and specify complete catalog number.

Refer to additional ordering information and specify one or more codes for each transmitter if additional options are required.

BASE MODEL - 1 <sup>st</sup> to 6 <sup>th</sup> characters			2	6	N	R	H	X	X	X	X	X	
Absolute Pressure Transmitter with remote seal – BASE ACCURACY 0.10 %													
<b>SENSOR - Span limits</b> - 7 <sup>th</sup> character													
1.1 and 65 kPa	11 and 650 mbar	4.35 and 260 inH2O						G					
2.67 and 160 kPa	26.7 and 1600 mbar	10.7 and 642 inH2O						H					
10 and 600 kPa	0.1 and 6 bar	1.45 and 87 psi						M					
40 and 2400 kPa	0.4 and 24 bar	5.8 and 348 psi						P					
134 and 8000 kPa	1.34 and 80 bar	19.4 and 1160 psi						Q					
267 and 16000 kPa	2.67 and 160 bar	38.7 and 2320 psi						S					
<b>Diaphragm material / Fill fluid</b> - 8 <sup>th</sup> character													
AISI 316 L ss		Silicone oil						NACE	R				
AISI 316 L ss		Inert fluid - Galden	(Note 1)					NACE	2				
AISI 316 L ss		Inert fluid - Halocarbon	(Note 1)					NACE	W				
<b>Process connection</b> - 9 <sup>th</sup> character													
Remote seal (except button type)			(one seal to be quoted separately)								R		
<b>Housing material and electrical connection</b> - 10 <sup>th</sup> character													
Aluminium alloy ( barrel version)		1/2 – 14 NPT										A	
Aluminium alloy ( barrel version)		M20 x 1.5 (CM 20)										B	
Aluminium alloy ( barrel version)		Harting Han 8D connector	(general purpose only)						(Note 2)			E	
Aluminium alloy ( barrel version)		Fieldbus connector	(general purpose only)						(Note 2)			G	
AISI 316 L ss ( barrel version)		1/2 – 14 NPT										S	
AISI 316 L ss ( barrel version)		M20 x 1.5 (CM20)										T	
AISI 316 L ss ( barrel version)		Fieldbus connector	(general purpose only)						(Note 2)			Z	
Aluminium alloy (DIN version)		M20 x 1.5 (CM20)	(not Ex d or XP)									J	
Aluminium alloy (DIN version)		Harting Han 8D connector	(general purpose only)						(Note 2)			K	
Aluminium alloy (DIN version)		Fieldbus connector	(general purpose only)						(Note 2)			W	
<b>Output/Additional options</b> - 11 <sup>th</sup> character													
HART digital communication and 4 to 20 mA		No additional options							(Notes 3, 4)			H	
HART digital communication and 4 to 20 mA		Options requested by "Additional ordering code"							(Note 4)			1	
PROFIBUS PA		No additional options							(Notes 3, 4)			P	
PROFIBUS PA		Options requested by "Additional ordering code"							(Note 4)			2	
FOUNDATION Fieldbus		No additional options							(Notes 3, 5)			F	
FOUNDATION Fieldbus		Options requested by "Additional ordering code"							(Note 4)			3	
HART and 4 to 20 mA Safety - certified to IEC 61508		No additional options							(Notes 3, 4)			T	
HART and 4 to 20 mA Safety - certified to IEC 61508		Options requested by "Additional ordering code"							(Note 3)			8	

## ADDITIONAL ORDERING INFORMATION for model 266NRH

Add one or more 2-digit code(s) after the basic ordering information to select all required options

	XX	XX	XX	XX
<b>Hazardous area certifications</b>				
ATEX Intrinsic Safety II 1 G and II 1/2 G Ex ia IIC T6; II 1 D Ex iaD 20 T 95 °C and II 1/2D Ex iaD 21 T95 °C	(Notes 3, 4)	E1		
ATEX Explosion Proof Group II Category 1/2 G Ex d IIC T6 and Group II Category 1/2 D Ex tD A21 IP67 T85 °C	(Notes 3, 4, 5)	E2		
ATEX Type „N“ Group II Category 3 G Ex nL IIC T6 and Group II Category 3 D Ex tD A22 IP67 T85 °C	(Notes 3, 4)	E3		
Combined ATEX - Intrinsic Safety, Explosion Proof and Type „N“	(Notes 3, 4, 5)	EW		
Combined ATEX - Intrinsic Safety and Explosion Proof	(Notes 3, 4, 5)	E7		
Combined ATEX, FM Approvals (USA) and FM Approvals (Canada)	(Notes 3, 4, 5)	EN		
FM Approvals (Canada) approval	(Notes 3, 4, 5)	E4		
FM Approvals (USA) approval	(Notes 3, 4, 5)	E6		
FM Approvals (USA and Canada) Intrinsic Safety	(Notes 3, 4)	EA		
FM Approvals (USA and Canada) Explosion Proof	(Notes 3, 4, 5)	EB		
FM Approvals (USA and Canada) Nonincendive	(Notes 3, 4)	EC		
IEC Intrinsic Safety II 1 G and II 1/2 G Ex ia IIC T6; II 1 D Ex iaD 20 T 95 °C and II 1/2D Ex iaD 21 T95 °C;	(Notes 3, 4)	E8		
IEC Explosion Proof Group II Category 1/2 G Ex d IIC T6 and Group II Category 1/2 D Ex tD A21 IP67 T85 °C	(Notes 3, 4, 5)	E9		
IEC Group II Category 3 G Ex nL IIC T6 and Group II Category 3 D Ex tD A22 IP67 T85 °C	(Notes 3, 4)	ER		
Combined IEC - Intrinsic Safety, Explosion Proof and Type „N“	(Notes 3, 4, 5)	EI		
Combined IEC - Intrinsic Safety and Explosion Proof	(Notes 3, 4, 5)	EH		
NEPSI Intrinsic Safety Ex ia IIC T4~T6, DIP A20TA, T4~T6	(Notes 3, 4)	EY		
NEPSI Explosion Proof Ex d IIC T6, DIP A21TA, T6	(Notes 3, 4, 5)	EZ		
NEPSI Type „N“ Ex nL IIC T4~T6, DIP A22TA, TT6	(Notes 3, 4)	ES		
Combined NEPSI - Intrinsic Safety, Explosion Proof and Type „N“	(Notes 3, 4, 5)	EQ		
Combined NEPSI - Intrinsic Safety and Explosion Proof	(Notes 3, 4, 5)	EP		
<b>Other hazardous area certifications</b>				
GOST (Russia) EEx ia	(Notes 3, 4)	W1		
GOST (Russia) EEx d	(Notes 3, 4, 5)	W2		
GOST (Kazakhstan) EEx ia	(Notes 3, 4)	W3		
GOST (Kazakhstan) EEx d	(Notes 3, 4, 5)	W4		
Inmetro (Brazil) EEx ia	(Notes 3, 4)	W5		
Inmetro (Brazil) EEx d	(Notes 3, 4, 5)	W6		
Inmetro (Brazil) EEx nL	(Notes 3, 4)	W7		
Combined Inmetro (Brazil) - Intrinsic Safety, Explosion Proof and Type „N“	(Notes 3, 4, 5)	W8		
<b>Integral LCD</b>				
Digital LCD integral display			L1	
TTG (Through-The-Glass) digital LCD controlled display			L5	
<b>Mounting bracket (shape and material)</b>				
For pipe/wall mounting - Carbon steel	(Not suitable for AISI housing)			B1
For pipe/wall mounting - AISI 316 L ss				B2
<b>Surge</b>				
Surge/Transient Protector				S2

# Model 266DRH Differential

## Model 266PRH and 266HRH Gauge

## Model 266VRH and 266NRH Absolute

<b>ADDITIONAL ORDERING INFORMATION for model 266NRH</b>	<b>XX</b>	<b>XX</b>	<b>XX</b>	<b>XX</b>	<b>XX</b>
<b>Operating manual (up to 2 different selections allowed)</b>					
German (ONLY FOR HART and PROFIBUS VERSIONS)	M1				
Italian (ONLY FOR HART VERSION)	M2				
Spanish (ONLY FOR HART VERSION)	M3				
French (ONLY FOR HART VERSION)	M4				
English	M5				
Chinese (ONLY FOR HART VERSION)	M6				
Swedish (ONLY FOR HART VERSION)	M7				
Polish (ONLY FOR HART VERSION)	M9				
Turkish (ONLY FOR HART VERSION)	MT				
<b>Plates language</b>					
German		T1			
Italian		T2			
Spanish		T3			
French		T4			
<b>Additional tag plate</b>					
Supplemental wired-on stainless steel plate				I1	
Laser printing of tag on stainless steel plate				I2	
<b>Configuration</b>					
Standard – Pressure = inH2O/ psi at 68 °F; Temperature = deg. F					N2
Standard – Pressure = inH2O/ psi at 39.2 °F; Temperature = deg. F					N3
Standard – Pressure = inH2O/ psi at 20 °C; Temperature = deg. C					N4
Standard – Pressure = inH2O/ psi at 4 °C; Temperature = deg. C					N5
Custom					N6
<b>Certificates (up to 2 different selections allowed)</b>					
Inspection certificate EN 10204–3.1 of calibration (9-point)					C1
Inspection certificate EN 10204–3.1 of the cleanliness stage					C3
Inspection certificate EN 10204–3.1 of helium leakage test of the sensor module					C4
Inspection certificate EN 10204–3.1 of the pressure test					C5
Certificate of compliance with the order EN 10204–2.1 of instrument design					C6
Overfill protection					C9
Printed record of configured data of transmitter					CG
PMI test of wetted parts					CT



ADDITIONAL ORDERING INFORMATION FOR MODEL 266NRH			XX	XX	XX	XX
<b>Approvals</b>						
GOST (Russia) without Ex	(NOT APPLICABLE WITH ANY HAZARDOUS AREA CERTIFICATION)	Y1				
GOST (Kazakhstan) without Ex	(NOT APPLICABLE WITH ANY HAZARDOUS AREA CERTIFICATION)	Y2				
GOST (Belarus) without Ex	(NOT APPLICABLE WITH ANY HAZARDOUS AREA CERTIFICATION)	Y4				
Chinese pattern without Ex	(NOT APPLICABLE WITH ANY HAZARDOUS AREA CERTIFICATION)	Y5				
DNV approval					YA	
Lloyd approval					YB	
Approval for Custody transfer					YC	
Bureau Veritas approval					YD	
<b>Material traceability</b>						
Certificate of compliance with the order EN 10204–2.1 of process wetted parts						H1
Inspection certificate EN 10204–3.1 of process wetted parts						H3
Test report EN 10204–2.2 of pressure bearing and process wetted parts						H4
<b>Connector</b>						
Fieldbus 7/8 in. (Recommended for FOUNDATION Fieldbus) - (supplied loose without mating female plug)		(Notes 4, 6)				U1
Fieldbus M12x1 (Recommended for PROFIBUS PA) - (supplied loose without mating female plug)		(Notes 4, 6)				U2
Harting Han 8D – straight entry - (supplied loose)		(Notes 3, 6)				U3
Harting Han 8D – angle entry - (supplied loose)		(Notes 3, 6)				U4

Note 1: Suitable for oxygen service - NOT AVAILABLE FOR SENSOR CODE V

Note 2: Select type in additional ordering code

Note 3: Not available with Housing code G, Z, W

Note 4: Not available with Housing code E, K

Note 5: Not available with Housing code J, K, W

Note 6: Not available with Housing code A, B, S, T, J

### Standard delivery items (can be differently specified by additional ordering code)

- General purpose (no electrical certification)
- No display, no mounting bracket, no surge protection
- Multilanguage short-form operating instruction manual and labels in english
- Configuration with kPa and deg. C units
- No test, inspection or material traceability certificates

### IMPORTANT REMARK FOR ALL MODELS

THE SELECTION OF SUITABLE WETTED PARTS AND FILLING FLUID FOR COMPATIBILITY WITH THE PROCESS MEDIA IS A CUSTOMER'S RESPONSIBILITY, IF NOT OTHERWISE NOTIFIED BEFORE MANUFACTURING.

### NACE COMPLIANCE INFORMATION

- (1) The materials of constructions comply with metallurgical recommendations of NACE MR0175/ISO 15156 for sour oil field production environments. As specific environmental limits may apply to certain materials, please consult latest standard for further details. Selected materials also conform to NACE MR0103 for sour refining environments.
- (2) NACE MR-01-75 addresses bolting requirements in two classes:
  - Exposed bolts: bolts directly exposed to the sour environment or buried, encapsulated or anyway not exposed to atmosphere
  - Non exposed bolts: bolts exposed to the atmosphere.
 266 bolting identified by "NACE" are in compliance to the requirements of NACE MR-01-75 when considered "exposed bolting"

Model 266DRH Differential  
Model 266PRH and 266HRH Gauge  
Model 266VRH and 266NRH Absolute



# Contact us

## **ABB Ltd.**

### **Process Automation**

Howard Road  
St. Neots  
Cambridgeshire PE19 8EU  
UK  
Tel: +44 (0)1480 475321  
Fax: +44 (0)1480 217948

## **ABB Inc.**

### **Process Automation**

125 E. County Line Road  
Warminster  
PA 18974  
USA  
Tel: +1 215 674 6000  
Fax: +1 215 674 7183

## **ABB Automation Products GmbH**

### **Process Automation**

Schillerstr. 72  
32425 Minden  
Germany  
Tel: +49 551 905 534  
Fax: +49 551 905 555

## **ABB S.p.A.**

### **Process Automation**

Via Statale 113  
22016 Lenno (CO)  
Italy  
Tel: +39 0344 58111  
Fax: +39 0344 56278

[www.abb.com](http://www.abb.com)

## Note

We reserve the right to make technical changes or modify the contents of this document without prior notice. With regard to purchase orders, the agreed particulars shall prevail. ABB does not accept any responsibility whatsoever for potential errors or possible lack of information in this document.

We reserve all rights in this document and in the subject matter and illustrations contained therein. Any reproduction, disclosure to third parties or utilization of its contents - in whole or in parts - is forbidden without prior written consent of ABB.

Copyright© 2011 ABB  
All rights reserved

3KXP200016R1001

<sup>TM</sup> Hastelloy C-276 is a Cabot Corporation trademark  
<sup>TM</sup> Hastelloy C-2000 is an Haynes International trademark  
<sup>TM</sup> Monel is an International Nickel Co. trademark  
<sup>TM</sup> Viton is a Dupont de Nemour trademark  
<sup>TM</sup> DC200 is a Dow Corning Corporation trademark  
<sup>TM</sup> DC704 is a Dow Corning Corporation trademark  
<sup>TM</sup> Galden is a Montefluos trademark  
<sup>TM</sup> Halocarbon is a Halocarbon Products Co. trademark  
<sup>TM</sup> Baysilone is a GE Bayer trademark  
<sup>TM</sup> Neobee M-20 is a Stepan Company trademark  
<sup>TM</sup> Esso Marcol 122 is a Esso Italiana trademark  
<sup>TM</sup> Syltherm is a Dow Chemical Company trademark