

Data sheet

# Pressure switch, Differential pressure switch and Thermostat RT-E



The RT-E series consist of pressure and differential pressure switches as well as thermostats. The units are designed for industrial refrigeration and general industrial application in explosive zones acc. to 2014/34/EU Atex directive, explosive zone 1, for surface equipment, category 2.

It includes usage in refrigeration systems with ammonia, hydrocarbons and other applications where presence of flammable gases, vapours and mists are likely to occur.

RT-E pressure switches and thermostats for use in explosive zones incorporate SPDT changeover switch where contact position depends on pressure or temperature value of the system.

## Features

- Designed for use in explosive zone 1
- Versions with enclosure IP66
- Stainless steel frame
- Metallized front cover without window
- Gold plated contacts
- Safety Integrity Level: SIL 2 according to IEC 61508

## Approvals

CE marked, according to EN 60947-4/-5  
IECEX ULD 14.0013X  
DEMKO 14 ATEX 1406X  
marking: Ex II 2G Ex ia IIC T6...T1 Gb  
CE marked acc. to 2014/68/EU category IV, safety equipment: RTE6AEW, RTE6AEB, RTE6AES

China Compulsory Certificate, CCC  
EAC

**Technical data**

Enclosure *)	IP66 or IP54 (version with external manual reset)
Ambient temperature	-20 – 65 °C
Cable entry	2 x Pg 13.5 Cable diameter: 6 – 14 mm
Contact material	Gold plated AgCdO
Contact load	Must be used with a certified Ex ia barrier satisfying the input parameters
Contact system	Single-pole changeovers switch (SPDT)

\*) IP degree can only be obtained on enclosure without fractures / damages. RT-E must be protected against unintended impacts.

**Ordering**
*Pressure switches for R717 <sup>1)</sup>, HCFC, HFC and HC refrigerants*

Type	Regulating range [bar]	Differential Δp [bar]	Max. working pressure PS [bar]	Reset	Code no.	
					Connection	
					G 3/8 A + welded nipple ø6.5/10 mm	G 3/8 A
RT 112E	0.1 – 1.1	0.07 – 0.16	7	Auto	—	017-518566
RT 113E	0.0 – 0.3	0.01 – 0.05	0.4	Auto	—	017-519566
RT 121E	-1.0 – 0.0	0.09 – 0.40	7	Auto	—	017-618466
RT 1AE	-0.8 – 5.0	0.5 – 1.6	22	Auto	017-500966	—
RT 116E	1 – 10	0.3 – 1.3	22	Auto	—	017-520166
RT 5E	4 – 17	1.2 – 4	22	Auto	—	017-525266
RT 6AEW <sup>3)</sup>	5 – 25	3	34 <sup>2)</sup>	Auto	017-513866	—
RT 6AEB <sup>3)</sup>	10 – 28	1.5	34 <sup>2)</sup>	Man. (Max.)	017-513466	—
RT 6AES <sup>3)</sup>	10 – 28	1.5	34 <sup>2)</sup>	Man. (Max.)	017-502166	—
RT 117E	10 – 30	1 – 4	42	Auto	—	017-529866

<sup>1)</sup> Only types with letter A are suitable for R717

<sup>2)</sup> Max. working pressure acc. to PED is limited to 28 bar

<sup>3)</sup> W=Wächter (pressure control)

B = Begrenzer (pressure control with external reset)

S = Sicherheitsdruckbegrenzer (pressure control with internal reset)

*Differential pressure switches for R717, HCFC, HFC and HC refrigerants*

Type	Regulating range	Differential Δp [bar]	Operating range for LP bellows [bar]	Max. working pressure PS [bar]	Pressure connection	Code no.
	[bar]					
RT 260AE	0.5 – 4	0.3	-1 – 18	22	G 3/8 A + welded nipple ø6.5/10 mm	017D003666
RT 262AE	0.1 – 1.5	0.1	-1 – 9	11		017D003066

*Thermostats*

Type	Regulating range [°C]	Differential Δp		Max. sensor temperature [°C]	Type of charge	Capillary tube length [m]	Code no.
		at lowest range setting [°C]	at highest range setting [°C]				
		RT 9E	-45 – -15				
RT 14E	-5 – 30	2 – 8	2 – 10	150	Adsorption	2	017-509866
RT 14E	-5 – 30	2 – 8	2 – 10	150	Adsorption	5	017-617966
RT 101E	25 – 90	2.4 – 10	3.5 – 20	300	Adsorption	2	017-512666
RT 101E	25 – 90	2.4 – 10	3.5 – 20	300	Adsorption	5	017-618066
RT 107E	70 – 150	6 – 25	1.8 – 8	215	Partial	2	017-515366
RT 107E	70 – 150	6 – 25	1.8 – 8	215	Partial	5	017-618266
RT 123E	150 – 250	6.5 – 30	1.8 – 9	300	Partial	2	017-521666
RT 123E	150 – 250	6.5 – 30	1.8 – 9	300	Partial	5	017-618366

*Sensor pockets of RT-E thermostats*

RT 14E, RT 107E, RT 123E, RT 101E	Brass: 017-437066	18/8 stainless steel:	017-436966
-----------------------------------	-------------------	-----------------------	------------

**Safety requirements**

RT-E pressure, differential pressure switches and thermostats comply with the requirements for explosive atmosphere 2014/34/EU acc. to ATEX, zone 1.

Only apparatus designed, constructed and released by Danfoss must be used for application concerned. Danfoss can accept no responsibility in case of alterations made on the switches or the use of them against the Danfoss instructions. Original Danfoss spare parts approved for use in explosive atmosphere can only be used.

The application covers systems that must be located within the EU or EFTA and comply with the existing EU legislation, such as Pressure Equipment Directive (PED) 2014/68/EU, the directive concerning potential explosive atmosphere (ATEX) 2014/34/EU and other related EU standards. The system where RT-E is mounted must always comply with local directives, legislation or any other regulation applying in the area of installation. The Danfoss products comply with the requirements of ATEX directive, but Danfoss takes no responsibility for the classification of explosive zone.

**Electrical connection**

The RT-E pressure switch placed in explosive zone must always be wired through reliable zener barrier, placed outside ex-zone, to ensure insufficient energy supply to cause the ignition of surrounding atmosphere by an electrical spark or the heating of components of circuitry. The equipment to be used for electrical load limiting must always be approved for use in the zone concerned.

Cables and cable entries approved for the application must be used and can not be in contact with sharp edges. Cables must be connected with adequate stress relief that way that pulling forces can not be carried through the cable to the terminal.

**Wire dimension:** min. 0,75mm<sup>2</sup>

**Note:**

A particular system can be classified in different zones, for different parts of the system.

**Intrinsic safety protection method**

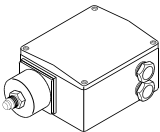
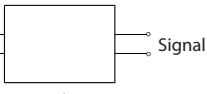
EX - zone	Non EX - zone	Electrical data for intrinsically safe specification (for all RT-E types):
		<p>           Ui: 29 V            Ii: 0.5 A            Pi: 1 W            Ci: 0.5 nF            Li: 0.2 μH         </p>

**Installation and maintenance**

Only authorised persons, who are certified in installing and maintaining the systems may do the installation, maintenance and change of the switch.

In the event of strong pulsation in the system, bellows must be protected against fatigue failure by use of damping coil.

The cycle frequency of the RT-E switch must be kept as low as possible. The vibration level must be kept as low as possible.

Any overload of the RT-E switch must be prevented. Overloaded or damaged apparatus must be exchanged.

**Design and function**

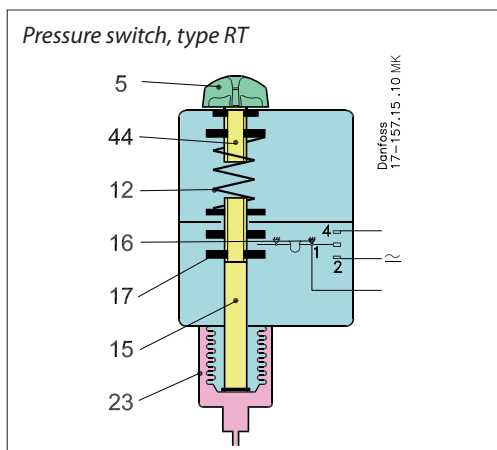

**Pressure switches**

RT-E switches are similar to non-explosive version of RT. Main design changes include stainless steel frame and metalised front cover to keep surface resistance below 1 Gohm. By turning setting knob (5) the main spring (12) can be set to balance the pressure in the bellows. A rise in pressure compresses the bellows and moves the main spindle (15) upwards until spring and bellows pressure are in equilibrium. The main spindle (15) is fitted with the guide bush (17) and differential pressure setting nut that together transfer the main spindle movement to the switch (16). RTE6AEW/B/S has double fail-safe bellows: outer and regulating (inner bellows).

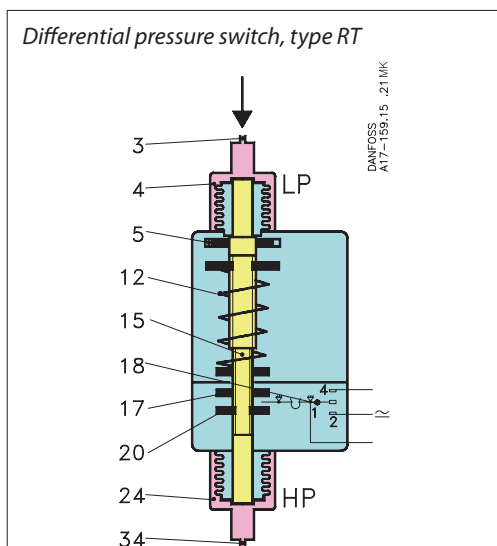

**Differential pressure switches**

An RT-E differential pressure switch contains single-pole changeover switch that makes or breaks depending on pressure differential between two counteracting bellows elements (LP and HP). The bellows (4) and (24) are respectively connected to lower pressure port and higher pressure port. The main spring (12) can be set for different differential pressure by the setting disc (5). If the differential pressure between higher and lower pressure falls, the spindle (15) moves downwards and via the upper guide bush (17) actuates the switch contact arm (18). The reverse action occurs if the differential pressure rises.

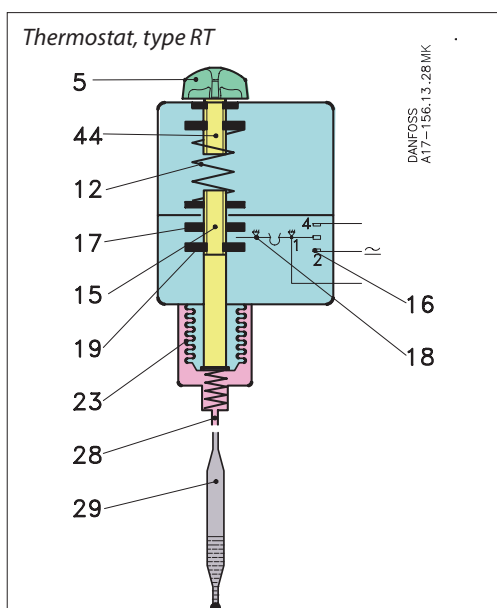

**Thermostats**

The thermostatic element consists of sensor (29), capillary tube (28) and bellows element (23). Charge in the element reacts to temperature variations and increases the pressure in the bellows when temperature rises. By turning the setting knob (5) the main spring (12) can be set to balance the pressure in the element. A rise in temperature of the sensor compresses the bellows and moves the main spindle (15) upwards until spring force and element pressure are in equilibrium. Such movement is transferred to the switch (16) and causes its on or off action.

**Settings**

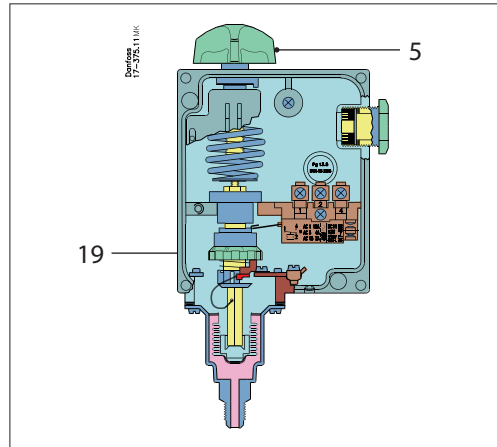

The range is set by using setting knob (5). Tools must be used to set switches fitted with seal cap. To read the range scale front cover must be removed. On the units with adjustable differential, differential disc (19) must be set after removing front cover. For proper adjustment differential roller must be used. Detailed information can be found in RT data sheets, non-explosive version.

**Dimensions [mm] and weights [kg]**

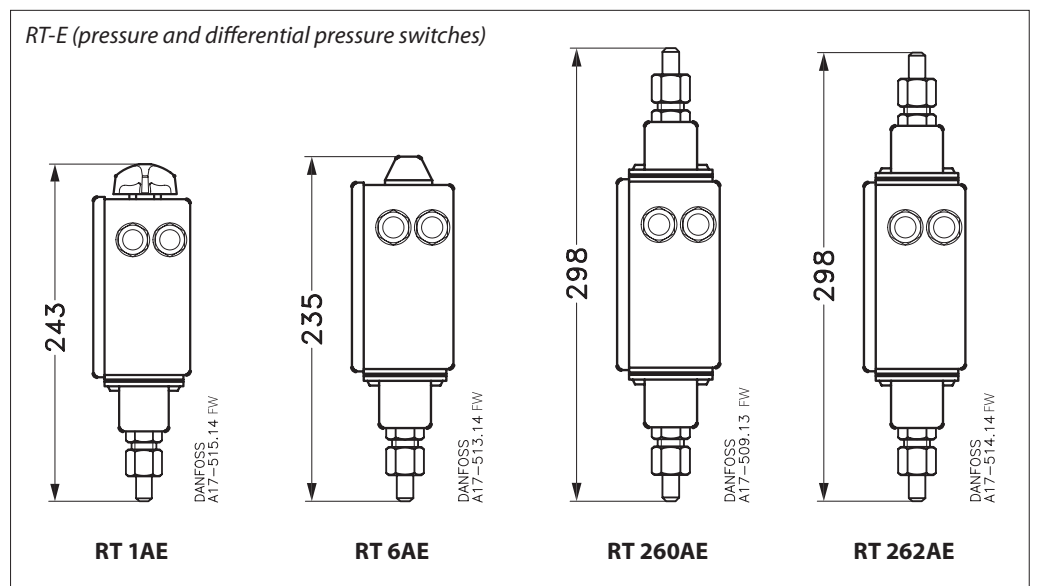
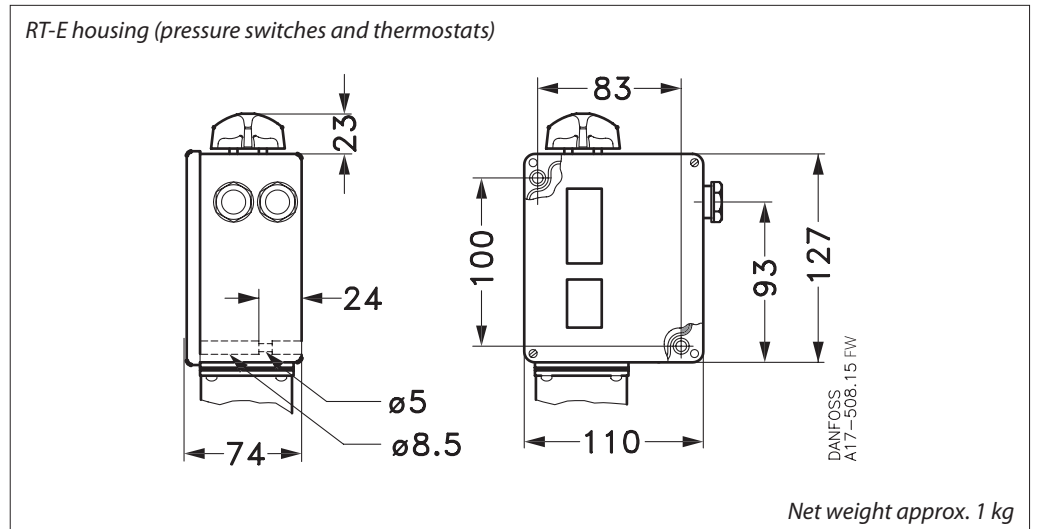

Danfoss can accept no responsibility for possible errors in catalogues, brochures and other printed material. Danfoss reserves the right to alter its products without notice. This also applies to products already on order provided that such alterations can be made without consequential changes being necessary in specifications already agreed. All trademarks in this material are property of the respective companies. Danfoss and the Danfoss logotype are trademarks of Danfoss A/S. All rights reserved.