



SIEMECA™

Electronic Water Meters

WFC...
WFH...

Electronic, mains-independent meters to acquire water consumption in autonomous domestic water plants.

Storage and display of the cumulated consumption values on a selectable set day.

Available as single-jet meters in «combined» all-in-one or split version

Nominal flow rates of single-jet meters 1.5 m³/h or 2.5 m³/h.

The electronic SIEMECA™ water meter is a component of the SIEMECA™ AMR System and SIEMECA™ M-Bus Metering.

Use

The electronic SIEMECA™ water meters are used for measuring water consumption. Their major field of use are central domestic water plants, where water is delivered individually to several consumers.

Plants of this type are used in buildings such as

- multi-family houses
- office and administrative buildings

Typical users are:

- Private building owners
- Property associations
- Building maintenance companies
- Housing estate agents

Functions

- Acquisition of water consumption
- Cumulation of the consumption values
- Storage of the cumulated consumption values on the set day
- Display of the consumption values
- Display of the key operational data
- Self-supervision, with fault indication
- Data transmission via M-bus or radio

Type summary

List of electronic single jet cold water meters (Max. water temperature: 30 °C)

Nominal flow rate q_n	Mounting length [mm]	Outside thread ["]	Communication	Type reference **
1,5 m ³ /h	80	G ³ / ₄	via M-bus *	WFC21.D080
1,5 m ³ /h	110	G ³ / ₄	via M-bus *	WFC21.D110
2,5 m ³ /h	130	G1	via M-bus *	WFC21.E130
1,5 m ³ /h	80	G ³ / ₄	via radio 868 MHz	WFC26.D080
1,5 m ³ /h	110	G ³ / ₄	via radio 868 MHz	WFC26.D110
2,5 m ³ /h	130	G1	via radio 868 MHz	WFC26.E130

* Prepared for communication via M-bus

** Short-form

List of electronic single jet cold water meters (Max. water temperature: 90 °C)

Nominal flow rate q_n	Mounting length [mm]	Outside thread ["]	Communication	Type reference **
1,5 m ³ /h	80	G ³ / ₄	via M-Bus *	WFH21.D080
1,5 m ³ /h	110	G ³ / ₄	via M-Bus *	WFH21.D110
2,5 m ³ /h	130	G1	via M-Bus *	WFH21.E130
1,5 m ³ /h	80	G ³ / ₄	via radio 868 MHz	WFH26.D080
1,5 m ³ /h	110	G ³ / ₄	via radio 868 MHz	WFH26.D110
2,5 m ³ /h	130	G1	via radio 868 MHz	WFH26.E130

* Prepared for communication via M-bus

** Short-form

List of accessories

Accessory	Description, scope of delivery	Type reference
Spacer	For mounting length 80 mm (³ / ₄ " male)	WFZ.R80
Spacer	For mounting length 110 mm (³ / ₄ " male))	WFZ.R110
Spacer	For mounting length 130 mm (1" male)	WFZ.R130
Threaded joints	¹ / ₂ " outside thread, ³ / ₄ " union nut	WFZ.R2
Threaded joints	³ / ₄ " outside thread, 1" union nut	WFZ.R2-1
Covering plate IV	Chromium-plated	WFZ.B4
M-bus connection kit	1 plug with cable (1 m long; 1 adhesive label)	WFZ.MBUSSET

Ordering

When ordering, please give type reference according to «Type summary».

The electronic SIEMECA™ water meter comes standard with an M-bus output. If the water meter is connected to a SIEMECA™ M-Bus Metering System, the M-bus connection kit is required.

If a set day other than 31 December is required, the desired month is to be added to the type reference when ordering (normally, the last day of the month is the set day).

Ordering example for a water meter, 110 mm mounting length, set day 30 April:
WFC21.D110, set day: April

Technical design

Measurement principle

The meter operates based on the single-jet measurement principle where the water jet hits the impeller tangentially. The impeller's speed is sensed electronically without producing a magnetic field.

Storage of consumption values

The water energy consumption values are continuously cumulated. At 23.59 hours of the next set day, the actual meter reading will be stored.

The set day is factory-set, the standard setting being 31 December (also refer to «Ordering»).

At the same time the annual consumption values are stored, the meter calculates a verification code. Tenants who make their own reading need to give this code to the billing centre, along with the set day reading. This enables the billing centre to verify the reading.

The stored set day value will be retained for one year.

Display

The water meter has three display levels which show the following values and variables:

- Cumulated water consumption since the last set day
- Segment test
- Actual flow rate
- Meter's number of operating hours since it was first installed
- Set day and set month
- Stored water consumption of previous year
- Stored water consumption of the last 13 month
- Verification code
- Cumulated water consumption since the meter was first installed
- Indication of faults (also refer to section below)

The units displayed are m³, m³/h and hours.

Standard display is the cumulated water consumption.

Fault status signals

The meter monitors itself and can display faults it has detected. It differentiates between two categories of faults.

- Temporary faults: they have no impact on the correct functioning of the meter. A arrow is flashing under the field "Fehler" ("Error").
- Severe functional faults: the measurements have been stopped. In that case, the display alternates between error code and date the fault occurred the first time. The values that have been cumulated until the fault first occurred remain stored.

Mechanical design

The water meter is comprised of flow measuring section and the electronic unit. The flow measuring section is mounted in the piping with the help of fittings. It is made of

nickel-plated brass and contains the measuring chamber with the single-jet impeller. The inlet has a strainer to retain larger dirt particles. The meter is supplied as a compact all-in-one unit, but the electronic unit can be detached if required (split version).

Electronic display unit

The electronic display unit houses the electronics and the eight-digit LCD. The operating voltage of DC 3 V is supplied by a lithium battery. Below the display, there is a button for advancing the display.

The electronic display unit on the flow measuring section can be swiveled through 270° and tilted by 90°.

Sizing

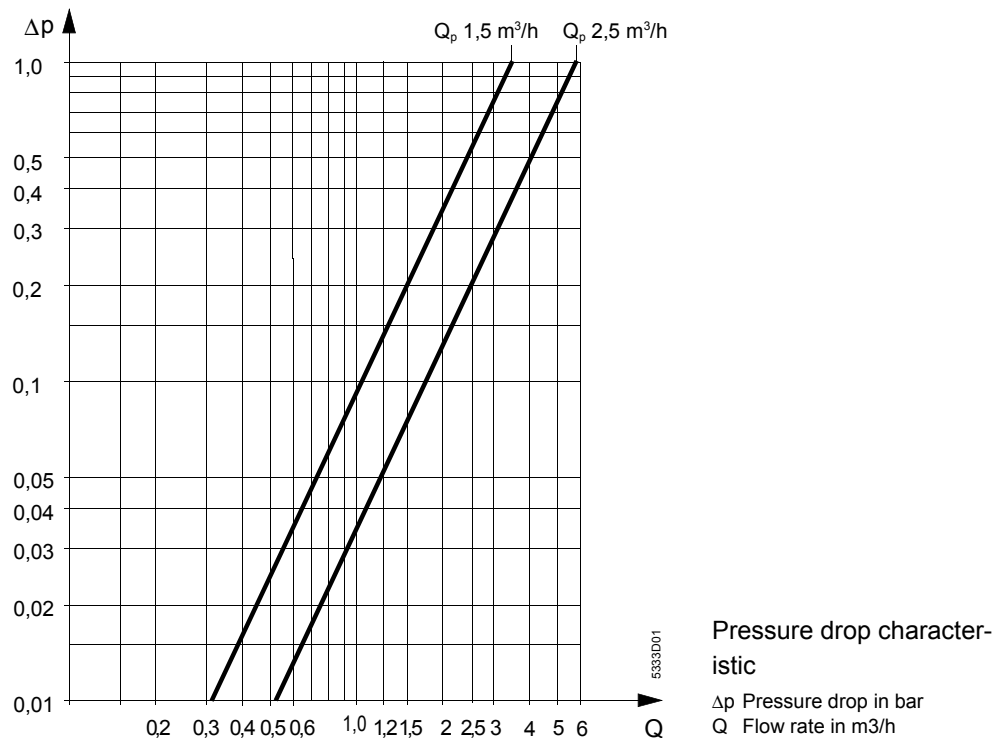

Mounting notes

- The local regulations for the use of water meters (mounting, sealing, operation, etc.) must be complied with
- To facilitate readout and service work, the meter should be easily accessible
- A settling path is required just upstream of the meter:
 - 150 mm with the mounting lengths 80 mm and 110 mm
 - 200 mm with the mounting length 130 mm
- If the meter is only used at the time of commissioning, it is possible to fit the spacer first
- Prior to mounting the meter, the piping must be thoroughly flushed; for this purpose, the spacer is to be used
- When mounting the meter, the direction of flow (indicated by an arrow on the body) must be observed
- The electronic display unit can be mounted away from the flow measuring section (split version). If the hole in the wall is too large for the display unit, it can be mounted with the help of the mounting cover. If required, a chromium-plated covering plate can be used
- The display unit should be located such that it is easy to read
- After mounting, the required test pressure must be applied to the plant

- The display unit and the fittings must be sealed to ensure protection against tampering.
If required, the M-bus service interface must also be sealed

Operating notes

- For recalibration, the local regulations must be observed.

Technical data

Measurement accuracy class (DIN ISO 4064/1)			
horizontal	B		
vertical	B		
Unit	m ³		
Flow rates	1.5 m ³ /h	2.5 m ³ /h	
Min. flow rate Q_{\min} H / V	30 l/h	50 l/h	
Lower limit of flow rate Q_t	120 l/h	200 l/h	
Nominal flow rate Q_{neff}	1500 l/h	2500 l/h	
Max. flow rate Q_{\max}	3000 l/h	5000 l/h	
Starting flow, horizontal	3 l/h	5 l/h	
Max. perm operating pressure	10 bar		
Range of use of flow measuring section	1... 90°C		
Output signal			
under measuring conditions	optional M-bus (EN 1434)		
in test mode	optional M-bus (EN 1434) optional voltage pulses (DC 3 V)		
Behavior in the event of excessive flow			
flow rate = 2 q_{\max}	linear		
flow rate > 2 q_{\max}	constant		
Perm. ambient temperature			
transport und storage	5...55 °C		
operation	max. 55 °C		
Degree of protection	IP 54		
Battery life	>8 years (>7 years for units with radio-based data transmission)		
Connections and weight	1.5 m ³ /h	1.5 m ³ /h	2.5 m ³ /h
Pipe connection (inlet and outlet)	3/4"	3/4"	1"
Mounting length	80 mm	110 mm	130 mm
Weight	0.55 kg	0.6 kg	0.7 kg

Dimensions

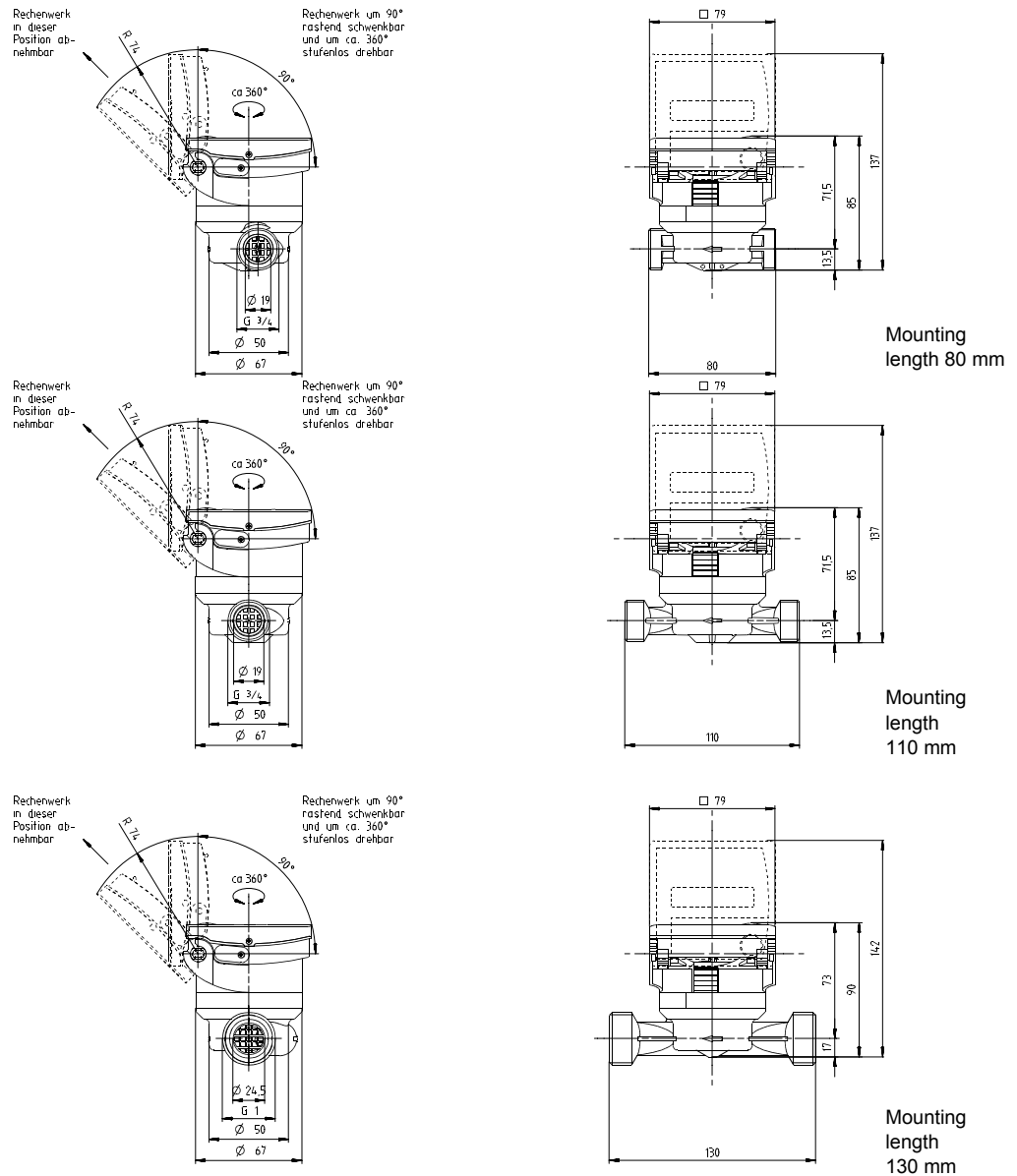

This data sheet contains only general descriptions for e.g. capability characteristics and other. In certain cases these characteristics could vary. Therefore it's absolutely essential to define the necessary details before signing the contract.

©2002 Siemens Building Technologies AG
 Subject to alterations