



Model **J3** – H55



Doc: J3-H55/01

Jan 2008

Feature rich **J+J** multi-voltage actuator with LED status light and plug & play accessories.

New in 2008, the **J3** range of electric actuators takes its highly successful predecessor, the J2 range, to the next level.

With an all new, rugged weatherproof and anti-corrosive Polyamide housing, the **J3** offers more user-friendly features than the J2, and introduces a highly visible LED status light.

This visual indicator shows whether the actuator is operating correctly, or has tripped out either by its electronic torque limiter, or has been left in 'manual' mode.

Site operators are no longer left with the 'valve or actuator?' question when an actuator doesn't respond to a signal.

The **J3** is quick and easy to install, with ISO:5211 multi-flange mounting and a double square drive, allowing fast

mounting to ISO:5211 valves. There is no need to remove the cover to connect the **J3** electrically, saving installation time.

Using the external DIN plugs and external wiring diagrams supplied with the actuator, installations can be pre-wired.



Protection against valve jams is provided by an electronic torque limiter, which auto-relaxes the gearbox when activated, allowing the manual override to be selected to assist in clearing the jam.

The effect of condensation is eliminated by an internal thermostatic anti-condensation heater that does not require a separate independent power supply.

Standard function for the **J3**-H55 is power open, power close, stays put on power failure.

New to the **J3** are plug and play accessories –the function can be changed to either failsafe or modulating by fitting the new plug and play conversion kits.

The modulating kit has the new digital positioner that offers auto-calibrating and self resetting functionality.

These conversion kits are available as optional extras.

The **J3** is a very smart red box!

Quick guide to the **J3**'s standard features :

*Multi-voltage with auto-voltage sensing.
110 ~ 24V0 AC or DC .*

LED Status light to indicate operational status of actuator

Electronic over-torque protection against valve jams

Thermostatic anti-condensation heater

Manual override for emergency hand operation

2 Volt free end of travel confirmation switches

IP65 weatherproof anti-corrosive and UV protected Polyamide housing

Local visual position indicator

ISO5211 multi-flange mounting with double square drive

All external electrical connections via supplied DIN plugs

CE marked

ISO 9000 manufacturer

Failsafe and digital positioner plug & play kits available.

J3 Status light functions:

Constantly lit LED

If the actuator is operating correctly with no faults, the LED shows a constantly lit light.



The LED flashes with 2 blinks

If the actuator has been left in 'manual' mode, the actuator's motor runs but doesn't drive the output shaft. After a pre-set time, the actuator knows that as the torque limiter has not activated and that the motor is running, it must be in manual.



The LED flashes on/ off

When the actuator senses an impending valve jam, the electronic torque limiter is activated and on activation, repeatedly flashes the LED on and off.



The all new **J3** - 55

Visual indication of the actuator's operating status is constantly shown by a highly visible LED light.

Specifications: **J3** – H55

Voltage range - automatically sensed by actuator	85-240 AC (1ph) or DC
Operating time (0-90° no load)	10 seconds
Maximum break torque	60 Nm / 560 lb.ins
Maximum operating torque (run/ reseal)	55 Nm / 486 lb.ins
Duty rating	75%
IP Rating (IEC 60529)	IP65
Working angle Standard (on request)	90° (180° or 270° options)
Mounting ISO:5211 x DIN 3337	F05 & F07 x 17
Motor switches	2 x SPDT micro switches
End of travel confirmation (volt free)	2 x SPDT micro switches
Heater	4 W
Ambient temperature range	-20° to +60° C
Electrical connecting plugs	DIN 43650/ ISO4400 & C192
Consumption:	
240V/1ph Maximum torque, heater on/ off	0.19 A/ 0.16A
240V DC Maximum torque, heater on/ off	0.09A/ 0.07A
110V/ 1ph Maximum torque, heater on/ off	0.31A/ 0.29A
110V DC Maximum torque, heater on/ off	0.16A/ 0.13A
Weight	2.0 kg

Materials of construction:

Housing	Anti-corrosive Polyamide
Fasteners	Stainless steel
Gears	Polyamide (speed reducing) & steel
Shaft	Stainless steel
Output drive	Zammac
Position indicator	Glass filled Polyamide

Method of operation:

On receipt of a continuous power signal within the voltage range shown above, the motor runs and, via a flat gear system, rotates the output shaft. The motor is stopped by internal cams striking micro switches. On receipt of a reversing continuous signal, the motor turns in the opposite direction reversing the output drive.

Note:

The power signal needs to remain on at all times to activate the thermostatic anti-condensation heater. The volt free end of travel confirmation switches must NOT be used to cut the power.

Dimensions: J3 - H55



Mounting	F05	F07
ISO: 521 I	50mm	70mm
Drive	17mm	
Optional	14mm	

The standard on-off version can have plug and play failsafe or modulating kits retro-fitted to convert the function.

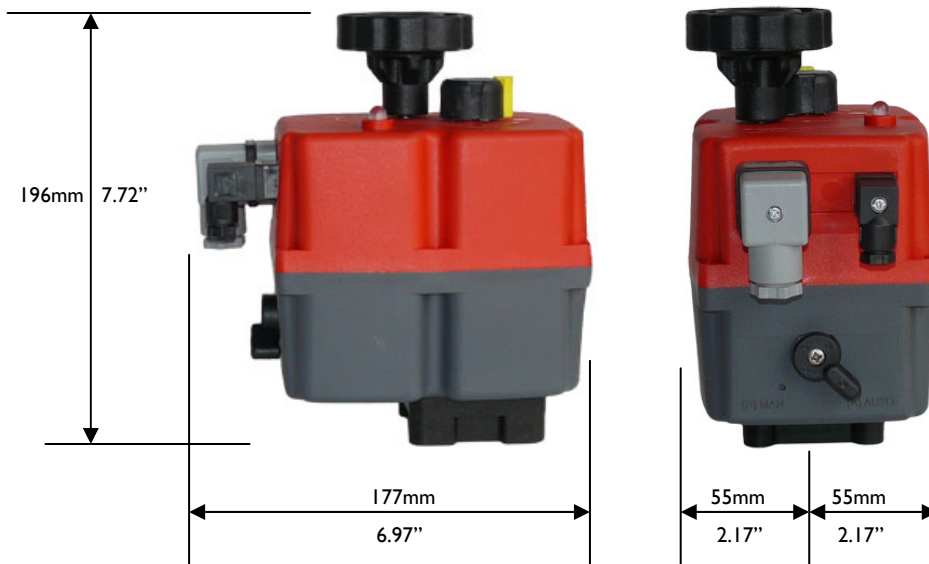

The modulating kit contains a self calibrating digital positioner.

Change of function retro-fit kits:

Failsafe option

This kit converts the actuator to a failsafe unit using a BSR (Battery 'Spring Return') system that provides an alternative (battery) power supply to set the actuator in the failsafe position should the main power supply fail.

It can be configured normally open, or normally closed.



Modulating Option

Using the new self calibrating and self adjusting digital positioning system, this kit converts the actuator to a modulating device using either a 4-20mA or 0-10VDC control signal.



LED status light





Model J3

Wiring Diagram - AC or DC



Doc: J3/STD.WD/01

Jan 2008

AC (1ph) OR DC SUPPLY - WIRING FOR ON-OFF OR FAILSAFE ACTUATORS

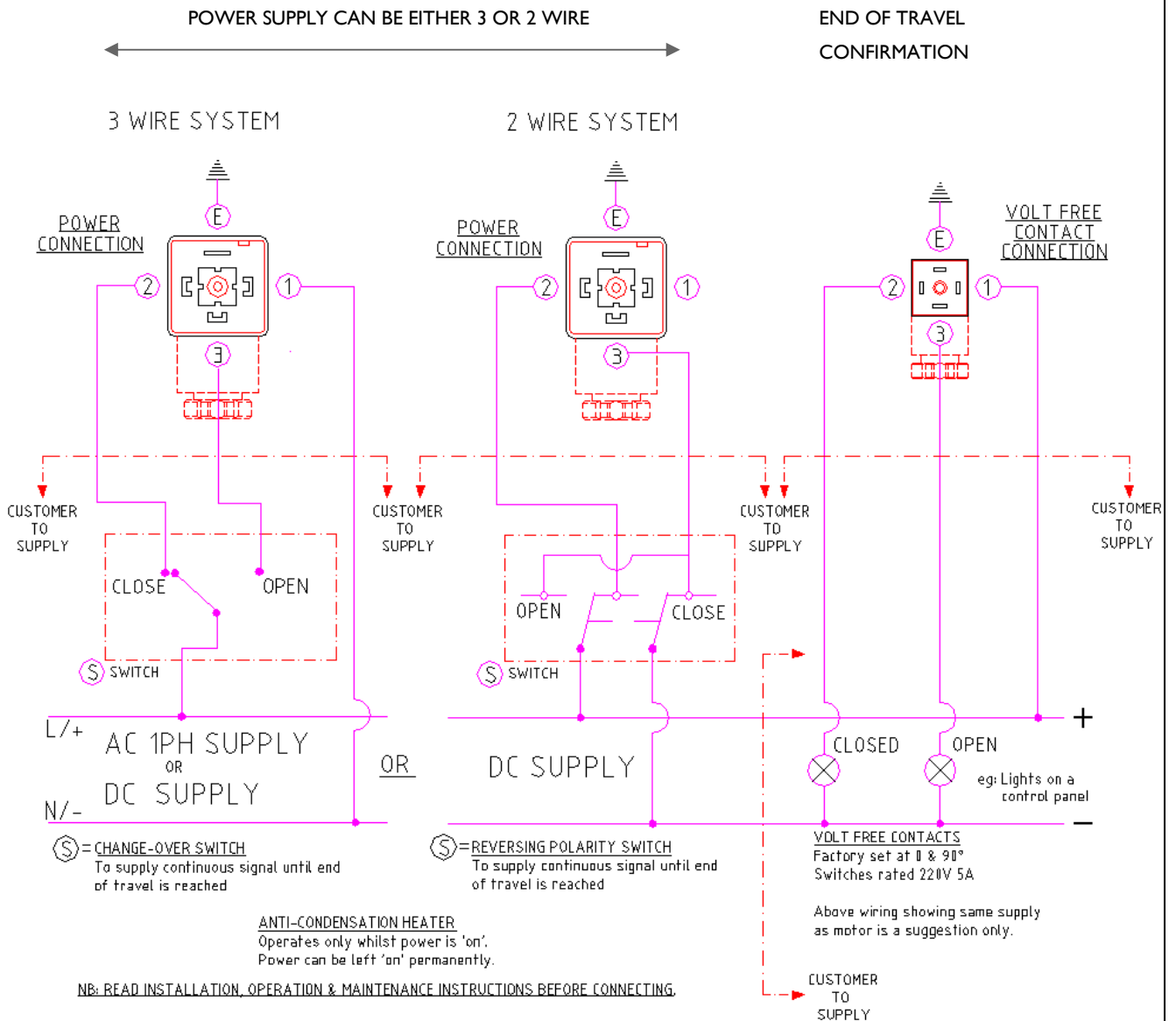

FUNCTION: ON-OFF VERSION

Power open, power close
Stays put on mains power failure

FUNCTION: FAILSAFE VERSION

Power open, power close - trickle charges battery system in either open or closed position
Actuator sent by battery power to pre-set failsafe position on power failure
Actuator returns to pre-failure position on power resumption.
Failsafe can be either NC (normally closed) or NO (normally open)



Model J3

Wiring Diagram - AC or DC



Doc: J3/STD.WD/01

Jan 2008

AC (1ph) OR DC SUPPLY - WIRING FOR MODULATING ACTUATORS

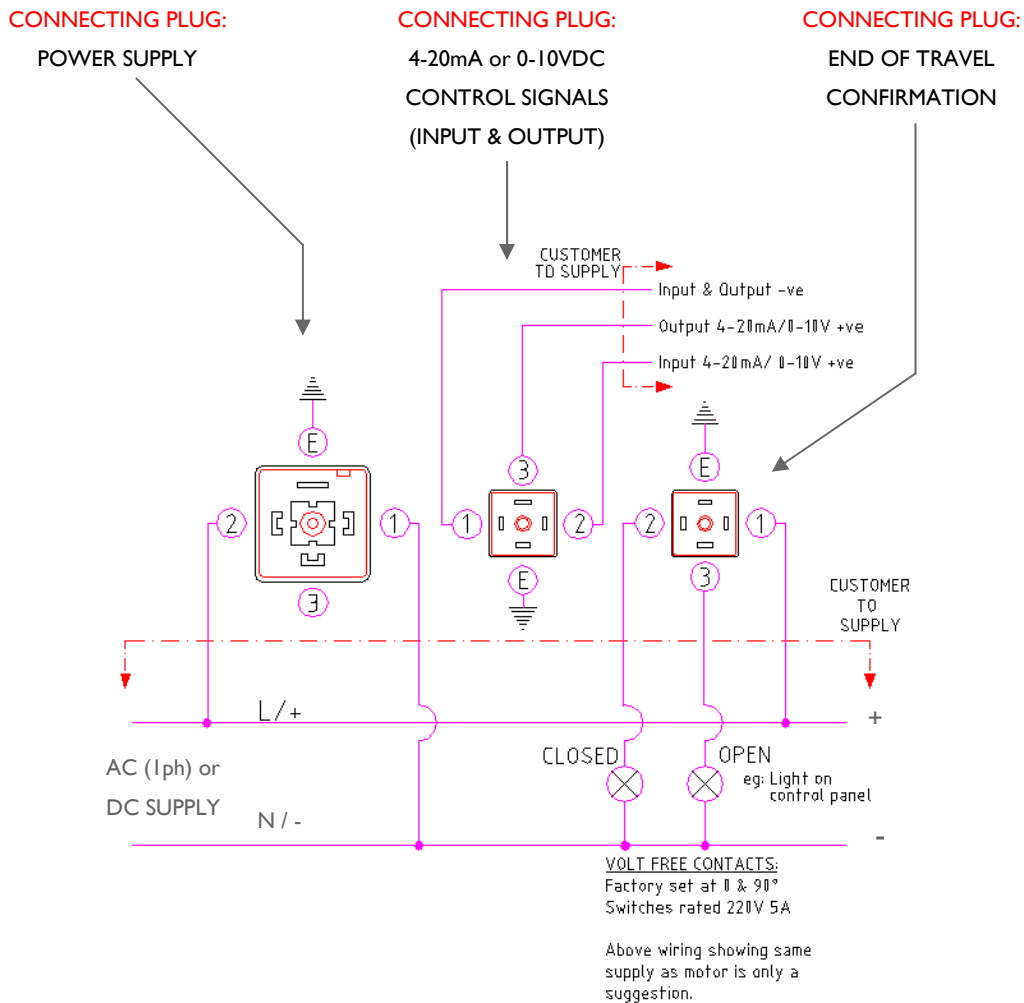

NB: READ INSTALLATION, OPERATION & MAINTENANCE INSTRUCTIONS BEFORE CONNECTING.

FUNCTION: MODULATING VERSION

Power open, power close - actuator movement controlled by input signal (4-20mA or 0-10VDC)
Standard operation: 4mA or 0V = actuator closed, 20mA or 10V = actuator open (can be reversed)
Standard operation: Actuator closes on loss of control signal, stays put on loss of mains power
Output signal (in same format as supply signal) provided as standard.



Acrodyne Pty Ltd
ABN 22 006 309 753 | Call 1300 422 882
www.acrodyne.com.au