

# Series 240

## Type 3351 Pneumatic On/off Valve



### Application

Tight-closing on/off valve for liquids, gases and vapors according to DIN or ANSI standards

<b>Valve size</b>	<b>DN 15 to 100 · NPS ½ to 4</b>
<b>Pressure rating</b>	<b>PN 10 to 40 · Class 150 and 300</b>
<b>Ambient temp.</b>	<b>-35 to +100 °C · -30 to +212 °F</b>
<b>Medium temp.</b>	<b>-50 to +250 °C · -58 to +482 °F</b>

The Type 3351 Pneumatic Control Valve consists of an on/off valve and a pneumatic actuator. Optionally, the valve can be equipped with a bellows seal or insulating section.

Valve body made of:

- Cast iron
- Spheroidal graphite iron
- Cast steel
- Cast stainless steel

### Special features

- Soft-seated valve plug
- Leakage class VI according to IEC 60534-4 or class VI according to ANSI/FCI 70-2
- Attachment of solenoid valves and limit switches according to IEC 60534-6 and NAMUR recommendation. Refer to Information Sheet ▶ T 8350 for more details.

### Versions

**Standard version** for pressure rating PN 10 to 40 or Class 150 and 300, fail-close or fail-open

- **Type 3351** (Fig. 1) · On/off valve with self-adjusting PTFE V-ring packing · Valve size DN 15 to 100 (NPS ½ to 4) · Medium temperatures from -10 to 220 °C (14 to 428 °F)
- **Type 3351 with bellows seal** · On/off valve with bellows seal and PTFE V-ring packing · Valve size DN 15 to 50 (NPS ½ to 2) · Medium temperatures according to Table 1
- **Type 3351 with insulating section** · On/off valve with insulating section and plug stem sealed by a PTFE V-ring packing · Valve size DN 15 to 50 (NPS ½ to 2) · Medium temperatures according to Table 1

### Further versions

- Additional handwheel
- Reinforced spring
- Higher or lower medium temperatures
- Higher ambient temperatures

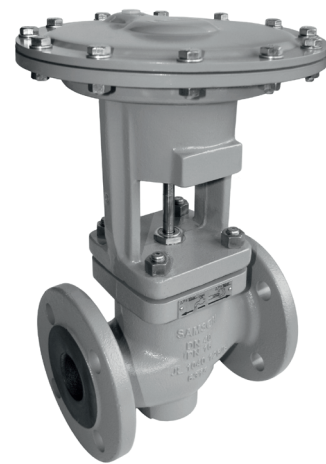

Fig. 1: Type 3351 Pneumatic On/off Valve



Fig. 2: Type 3351 Pneumatic On/off Valve · Version with handwheel

### Principle of operation

Depending on the type of valve seat and the arrangement of the valve plug, the valve has two different fail-safe actions which are used when the pressure acting on the diaphragm is reduced or when the control signal fails:

- **Fail-close action:** the valve is closed upon supply air failure.
- **Fail-open action:** the valve is opened upon supply air failure.

### Direction of flow

The direction of the medium flow in the valve depends on the process medium and the selected fail-safe action.

For fail-close valves which are used to control gases and vapors, the medium must flow in the closing direction (A → B), except for the DN 100 version, in which the medium must flow into the plug in the opening direction (B → A).

For control applications with liquids, the medium must flow into the plug in the opening direction (B → A).

In fail-open valves, all media must flow in the opening direction (A → B). For versions with the optional handwheel, a fail-close valve can be opened and a fail-open valve can be closed in the event of supply air failure.

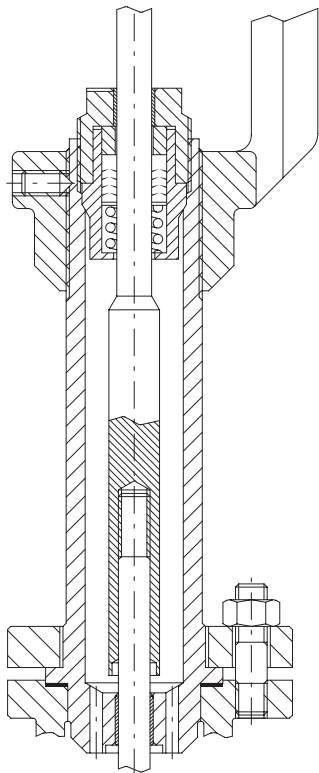

Fig. 3: Detailed drawing of the insulating section

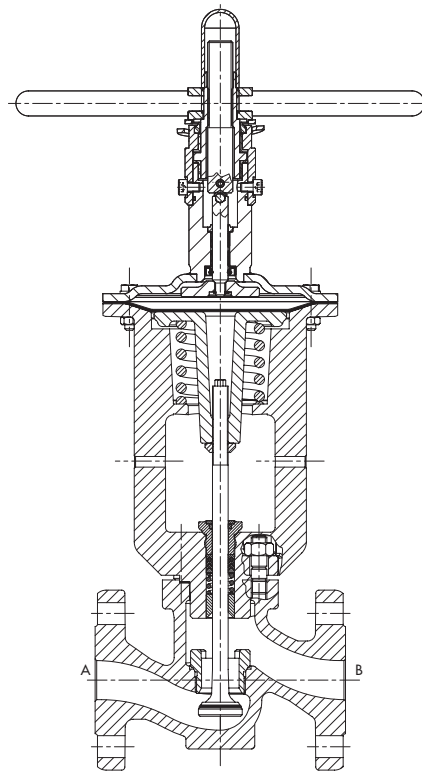

Fig. 4: Type 3351 Pneumatic On/off Valve with handwheel

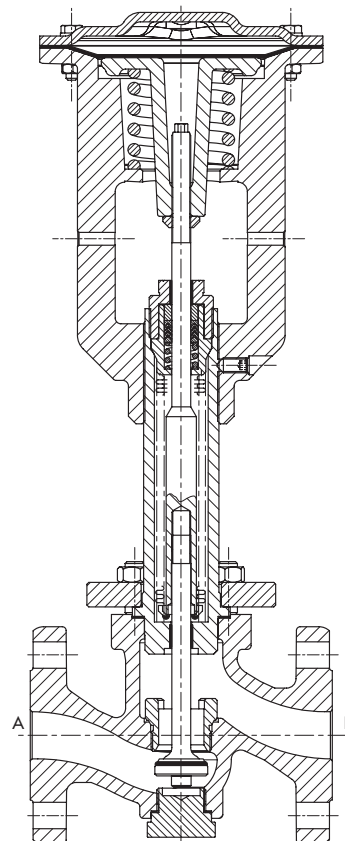

Fig. 5: Type 3351 Pneumatic On/off Valve - Version with bellows

**Table 1: Technical data**

Version		DIN			ANSI		
Body material		Cast iron EN-JL-1040	Spheroidal graphite iron EN-JS-1049	Cast steel 1.0619	Cast stainless steel 1.4408	Cast steel A216 WCC	Cast stainless steel A351 CF8M
Pressure rating		PN 10, 16	PN 10, 16, 25	PN 10, 16, 25, 40		Class 150 and 300	
Valve size	Standard	DN 15 to 100				NPS ½ to 4	
	Bellows seal/ insulating section	DN 15 to 50				NPS ½ to 2	
Connecting flanges		Form B according to DIN EN 1092-2		Form B1 according to DIN EN 1092-1		RF	
<b>Temperature ranges in °C (°F)</b> · Permissible operating pressures according to pressure-temperature diagrams (see Information Sheet ► T 8000-2)							
Ambient temperature		-35 to +100 °C (-30 to +212 °F)				-35 to +100 °C (-30 to +212 °F)	
Medium temperature (standard)		-10 to +220 °C (14 to 428 °F)				-10 to +220 °C (14 to 428 °F)	
High-temperature version <sup>2)</sup>		-10 to +240 °C (14 to 464 °F) <sup>1)</sup>				-10 to +240 °C (14 to 464 °F) <sup>1) 4)</sup>	
Low-temperature version		-	-50 to +220 °C (-58 to +428 °F) <sup>3) 4)</sup>		-29 to +220 °C (-20 to +428 °F) <sup>4)</sup>	-50 to +220 °C (-58 to +428 °F) <sup>3) 4)</sup>	
Leakage class		IEC 60534-4: VI				ANSI/FCI 70-2: Class VI	

<sup>1)</sup> With soft-seated special plug and bellows seal or insulating section

<sup>2)</sup> Higher temperatures (max. 450 °C/84 °F) with metal-seated plug and leakage class IV or V on request

<sup>3)</sup> Additional impact test certification required between -29 °C (-20 °F) and -50 °C (-58 °F)

<sup>4)</sup> With bellows seal or insulating section only

**Table 2: Materials**

Valve		DIN			ANSI		
Body		Cast iron EN-JL-1040	Spheroidal graphite iron EN-JS-1049	Cast steel 1.0619	Cast stainless steel 1.4408	Cast steel A216 WCC	Cast stainless steel A351 CF8M
Seat		1.4006			1.4404/1.4571	A182 F6a Cl. 2	316Ti/316L
Plug		1.4404 · Seal made of reinforced PTFE					
Body gasket		Graphite on metal core					
Actuator diaphragm		NBR (nitrile butadiene rubber) with fabric reinforcement Materials for higher or lower ambient temperatures on request					
<b>Standard version</b>							
Valve bonnet		Spheroidal graphite iron EN-JS-1049	Spheroidal graphite iron EN-JS-1049	Cast steel 1.0619	Valve cover 1.4571/1.4404 welded to bonnet 1.0619	Cast steel A216 WCC	Valve cover 316L welded to bonnet A216 WCC
Guide bushing		1.4104			1.4404	1.4104	316L
Packing		V-ring packing: PTFE with carbon · Spring: 1.4310					
Threaded bushing assembly		1.4404 + Carbon				316L + Carbon	
<b>Version with bellows seal or insulating section</b>							
Bellows seal/insulating section		1.0460			1.4404	A105	316L
Actuator flange		Cast iron	Cast steel			Cast steel	
		EN-JL-1040	1.0619			A216 WCC	
Guide bushing		Fiber-reinforced plastic					
Seal		Bellows seal: Bellows 1.4571 and PTFE/graphite V-ring packing · Spring 1.4310					
		Insulating section: PTFE/graphite V-ring packing · Spring 1.4310					
Guide nut assembly		1.4404 and fiber-reinforced plastic				316L and fiber-reinforced plastic	
Flange of bellows seal or insulating section		1.0460			1.4301	A105	304

**Table 3: Control pressure and maximum differential pressure · All pressures in bar and psi**

Valve size (bellows seal or insulating section up to DN 50/NPS 2)		DN	15	20	25	32	40	50	65	80	100	
		NPS	½	¾	1	–	1½	2	2½	3	4	
Flow coefficient	$K_{VS}$		6.3	10	14	25	31	40	72	90	170	
	$C_V$		7.5	12	16	–	36	47	84	105	200	
Pneumatic actuator	Actuator area in cm <sup>2</sup>		60			186			255		700	
	Travel in mm		8			10			12.5		30	
Max. supply pressure			6 bar/88 psi									
<b>Standard version</b>												
<b>Fail-close</b>												
Min. control pressure to open the valve at $\Delta p_{max}$			4 bar/58 psi									
Max. perm. differential pressure $\Delta p_{max}$ at	Vapors, gases A → B		20 bar/290 psi			16 bar/235 psi			10 bar/145 psi		10 bar	
	Liquids B → A		16 bar/235 psi			10 bar/145 psi			5 bar/73 psi		145 psi	
<b>Fail-open</b>												
Min. control pressure to close the valve at $\Delta p_{max}$			4.5 bar/65 psi								4 bar/ 58 psi	
Max. permissible differential pressure $\Delta p_{max}$ for vapors, gases or liquids			20 bar/290 psi			16 bar/235 psi			10 bar/145 psi			
<b>Special version for fail-close version for higher differential pressure <math>\Delta p</math></b>												
Min. control pressure to open the valve at $\Delta p_{max}$			5.5 bar/80 psi								–	
Max. permissible differential pressure $\Delta p_{max}$ for vapors, gases or liquids <sup>1)</sup>			30 bar/435 psi			20 bar/290 psi			7 bar/102 psi		–	

<sup>1)</sup> For direction of flow B → A (see Fig. 4)

**Table 4: Dimensions for Type 3351 (see Fig. 6)**

Valve		DN	15	20	25	32	40	50	65	80	100
		NPS	½	¾	1	–	1½	2	2½	3	4
Length L	PN 10/40	mm	130	150	160	180	200	230	290	310	350
	Class 150	in	7.25			–	8.75	10	10.88	11.75	13.86
		mm	184			–	222	254	276	298	352
	Class 300	in	7.50	7.63	7.75	–	9.25	10.50	11.50	12.50	14.49
mm		191	194	197	–	235	267	292	318	368	
Diaphragm ØD	mm	150			240			280		390	
Control pressure connection	α	G ¼			G ¼			G ⅜			
<b>Standard version</b>											
H1	mm	260			285			328		485	
H2	mm	45			72			98		118	
H3 <sup>1)</sup>	mm	380			380			415		565	
<b>Version with bellows seal or insulating section</b>											
H4	mm	400			415			–			
H2	mm	55			80						
H3 <sup>1)</sup>	mm	520			535						

<sup>1)</sup> Minimum clearance to remove the actuator; version with handwheel: up to DN 80: +150 mm, DN 100: +210 mm

**Table 5: Weights for Type 3351**

Standard version	DN	15	20	25	32	40	50	65	80	100
	NPS	½	¾	1	–	1½	2	2½	3	4
Weight, approx. kg	PN 10/40	11	12	12	25	26	29	48	52	70
	Class 150	11	12	13	–	23	27	47	52	64
	Class 300	12	13	14	–	25	29	50	55	64
Version with bellows seal or insulating section										
Weight, approx. kg	PN 10/40	16	17	17	33	34	37	–		
	Class 150	16	17	18	–	31	35			
	Class 300	17	18	19	–	33	37			

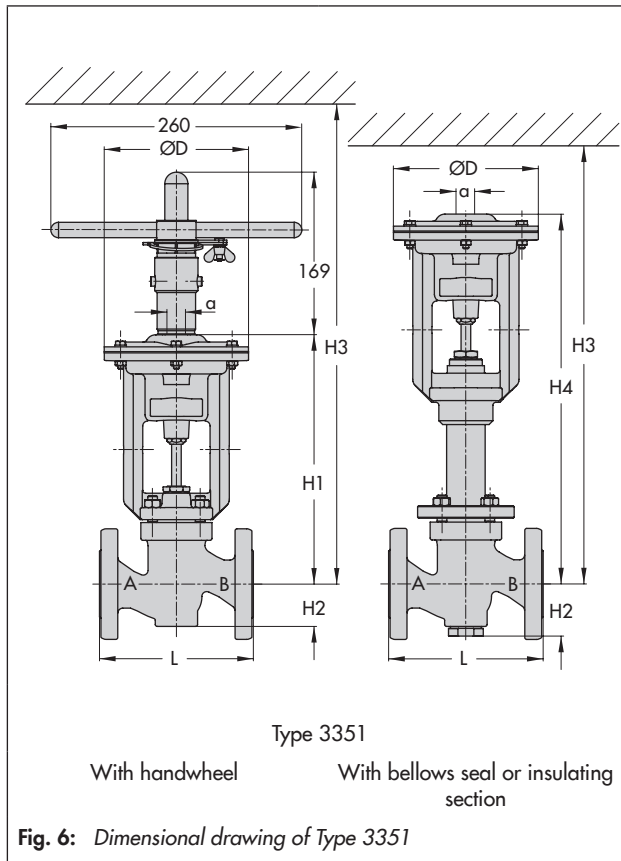

**Ordering text**

Type 3351 Pneumatic On/off Valve

Valve size DN/NPS

Nominal pressure PN/Class

Body material According to Table 1

Fail-safe position Fail-close or fail-open

Control air pressure ... bar

Handwheel With/without

Special version Bellows seal/insulating section  
High or low-temperature version

Valve accessories Solenoid valve and/or electric or pneumatic limit switch





Specifications subject to change without notice



SAMSON AG · MESS- UND REGELTECHNIK  
Weismüllerstraße 3 · 60314 Frankfurt am Main, Germany  
Phone: +49 69 4009-0 · Fax: +49 69 4009-1507  
samson@samson.de · www.samson.de

**T 8039 EN**

2015-04-14 · English